

# installation and servicing

## mini HE

Your Ideal installation and servicing guide

For details of document amendments, refer to page 3

## C24,C28

For users guide see reverse of book

When replacing any part of this appliance, use only spare parts that you can be assured conform to safety and performance specification that we require. Do not use reconditioned or copy parts that have not been clearly authorised by Ideal Boilers

17962.1138.1 0406 64A4 GB



For the very latest copy of literature for specification purposes please visit our website [www.idealboilers.com](http://www.idealboilers.com) where you will be able to download the relevant information in pdf format.

**i** Ideal BOILERS  
ENGINEERED FOR PEACE OF MIND



# DOCUMENT AMENDMENTS

Relevant Installation changes implemented in this book from Mod Level.....4905 to 0406

---

● **Pages 33 and 37**

Amendment to the illustration of the air pressure switch connection

---

*Caradon Ideal Limited reserve the right to vary specification without notice*

---

## GENERAL

**Table 1 – Boiler Data**

		mini HE C24	mini HE C28
Gas supply type & connection		I <sub>2</sub> H <sub>3</sub> P G20 20mbar, G31 37mbar, 22 mm copper	
Inlet / Outlet connection – Domestic Hot Water		15 mm copper	
Flow & return connection – Central Heating		22 mm copper	
Flue terminal diameter	mm (in.)	100 (4)	
Max working pressure (sealed system)	bar (lb/in <sup>2</sup> )	3.0 (43.5)	
Max DHW water inlet pressure	bar (lb/in <sup>2</sup> )	10.0 (145.0)	
Min DHW water inlet pressure	bar (lb/in <sup>2</sup> )	0.3 (4.4)	
Electrical supply		230 Vac 50 Hz	
Max power consumption	W	140	150
External fuse rating		3 A	
Internal fuse rating		T 2A	
Water content – CH	litre (gal.)	2.1 (0.46)	2.2 (0.48)
Water content – DHW	litre (gal.)	0.2 (0.044)	
Dry weight	kg (lb.)	42.5 (93.7)	44.5 (98.1)
Size: Height / Width / Depth	mm (in.)	803 (31 5/8") / 400 (15 3/4") / 345 (13 9/16")	
Lift weight	kg (lb.)	37.5 (82.7)	39.5 (87.1)

**Table 2 – Performance Data – Central Heating**

			mini HE C24		mini HE C28	
			Max	Min	Max	Min
Burner pressure (Hot)	G20	mbar (in.w.g.)	10.8 (4.3)	1.5 (0.6)	10.0 (4.0)	1.6 (0.6)
	G31		35.5 (14.2)	7.7 (3.1)	36.0 (14.4)	7.7 (3.1)
Input based on nett CV		kW (btu/h)	25.0 (85 295)	11.0 (37 530)	29.0 (98 942)	13.0 (44 353)
Input based on gross CV		kW (btu/h)	27.7 (94 516)	12.2 (41 628)	32.2 (109 871)	14.4 (49 135)
Output Non Condensing	G20	kW (btu/h)	24.6 (83 973)	10.2 (34 936)	28.3 (96 488)	12.1 (41 284)
	G31		23.7 (80 894)	10.2 (34 936)	27.4 (93 599)	12.1 (41 284)
Output Condensing	G20	kW (btu/h)	26.6 (90 754)	11.1 (37 871)	30.7 (104 602)	13.2 (44 965)
	G31		26.6 (90 754)	10.8 (36 997)	30.7 (104 602)	12.9 (44 016)
Gas consumption (Hot)	G20	l/s (ft <sup>3</sup> /h)	0.74 (93.6)	0.32 (40.9)	0.85 (108.4)	0.35 (45.2)
	G31		l/s	0.30	0.13	0.34
Seasonal efficiency*	G20 G31	(SEDBUK) %	Band B 87.7 Band B 86.9		Band B 87.5 Band B 87.0	
NOx classification			Class 2			

\*The value is used in the UK Government's Standard Assessment Procedure (SAP) for energy rating of dwellings. The test data from which it has been calculated have been certified by a notified body.

**Table 3 – Performance Data – Domestic Hot Water**

			mini HE C24	mini HE C28
			Maximum	
Burner pressure (Hot)	G20	mbar (in.w.g.)	10.8 (4.3)	10.0 (4.0)
	G31		35.5 (14.2)	36.0 (14.4)
Input based on nett CV		kW (btu/h)	25.0 (85 295)	29.0 (98 942)
Input based on gross CV		kW (btu/h)	27.7 (94 516)	32.2 (109 871)
Output Non Condensing	G20	kW (btu/h)	24.6 (83 973)	28.3 (96 488)
	G31		23.7 (80 894)	27.4 (93 599)
Output Condensing	G20	kW (btu/h)	26.6 (90 754)	30.7 (104 602)
	G31		26.6 (90 754)	30.7 (104 602)
Gas consumption (Hot)	G20	l/s (ft <sup>3</sup> /h)	0.74 (93.6)	0.85 (108.4)
	G31		l/s	0.30
Flow 35 °C temp. rise		l/m (gpm)	10.1 (2.2)	11.7 (2.6)
Domestic hot water specific rate		l/m (gpm)	11.9 (2.6)	13.9 (3.1)

Note: the gas consumption is calculated using a calorific value of 38.7 MJ/m<sup>3</sup> (1038 Btu/ft<sup>3</sup>) gross or 34.9 MJ/m<sup>3</sup> (935 Btu/ft<sup>3</sup>) nett.

To obtain the gas consumption at different calorific value: –

a. **FOR L/S** – divide the gross heat input (kW) by the gross C.V. of the gas (MJ/m<sup>3</sup>)

b. **FOR FT<sup>3</sup>/H** – divide the gross heat input (Btu/h) by the gross C.V. of the gas (Btu/ft<sup>3</sup>)

Key to Symbols:

IE = Ireland, GB = United Kingdom (Countries of destination)  
PMS = Maximum operating pressure of water  
C<sub>12</sub> C<sub>32</sub> C<sub>42</sub> = a room sealed appliance designed for connection via concentric ducts to a horizontal or vertical terminal or twin flue system.  
I<sub>2</sub>H<sub>3</sub>P = appliance designed for use on 2nd family gas group H or 3rd family gas group 3P

**CAUTION. To avoid the possibility of injury during the installation, servicing or cleaning of this appliance care should be taken handling edges of sheet steel components.**

## GENERAL

### mini HE

Boiler size	G.C. appliance No. (Benchmark No.)	PI No.
mini HE C24	47-348-38	0694BP0384
mini HE C28	47-348-39	0694BP0384

Destination countries: GB, IE

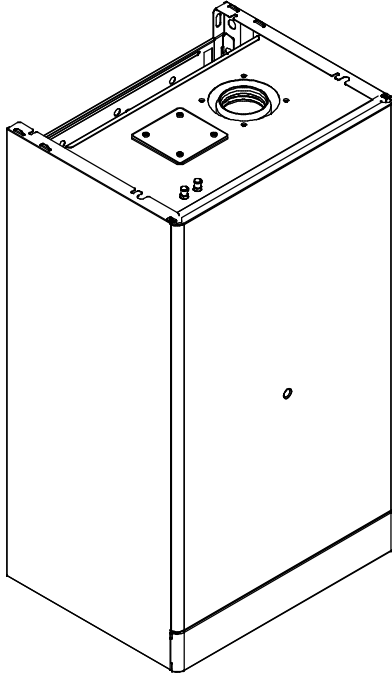

### CONTENTS

Air supply	9
Benchmark Commissioning Checklist	58
Boiler clearances	6
Boiler exploded view	14
Electrical connections	20
Electrical supply	10
Fault finding	48
Flow wiring diagram	24
Flue fitting	16
Gas conversion	29
Gas safety regulations	7
Gas supply	8
Installation	15
Mandatory requirements	7
Replacement of components	34
Safe handling	7
Servicing	30
Short list of parts	55
Thermostatic radiator valves	12
Water connections	19
Water treatment	9
Wiring diagrams	22

For GB, to comply with Building Regulations Part L1 (Part J in Scotland) the boiler should be fitted in accordance with the manufacturer's instructions. Self-certification that the boiler has been installed to comply with Building Regulations can be demonstrated by completing and signing the Benchmark Commissioning Checklist.

### BENCHMARK COMMISSIONING CHECKLIST DETAILS

Boiler	Page	Boiler	Page
Make and model	5	Burner operating pressure	measure and record
Appliance serial no. on data badge	14	Central heating flow temp.	measure and record
SEDBUK No. %	4	Central heating return temp.	measure and record
<b>Controls</b>		<b>For combination boilers only</b>	
Time and temperature control to heating	26	Scale reducer	12
Time and temperature control to hot water	26	Hot water mode	
Heating zone valves	26	Heat input	to be calculated
TRV's	12	Max. operating burner pressure	measure and record
Auto bypass	12	Max. operating water pressure	measure and record
Boiler interlock	12	Cold water inlet temp	measure and record
<b>For all boilers</b>		Hot water outlet temp.	measure and record
Flushing to BS.7593	9	Water flow rate at max. setting	measure and record
Inhibitor	9	<b>For condensing boilers only</b>	
Central heating mode		Condensate drain	20
Heat input	to be calculated	For all boilers: <i>complete, sign &amp; hand over to customer</i>	
		For assistance see Technical Helpline on the back page	

**NOTE TO THE INSTALLER: COMPLETE  
THE BENCHMARK COMMISSIONING  
CHECKLIST AND LEAVE THESE  
INSTRUCTIONS WITH APPLIANCE**



## GENERAL

### 1 BOILER WATER CONNECTION

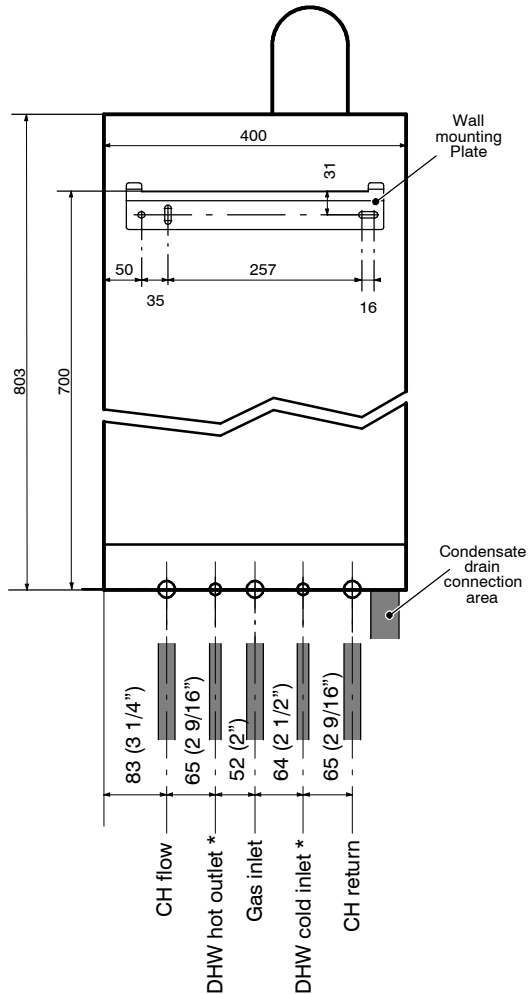

Pipe size	O.D. mm
CH flow	22
CH return	22
Gas inlet	22
DHW cold inlet	15
DHW hot outlet	15

### 2 BOILER CLEARANCES

All dimensions in mm (in.)

The following minimum clearances must be maintained for operation and servicing. Additional space will be required for installation, depending upon site conditions.

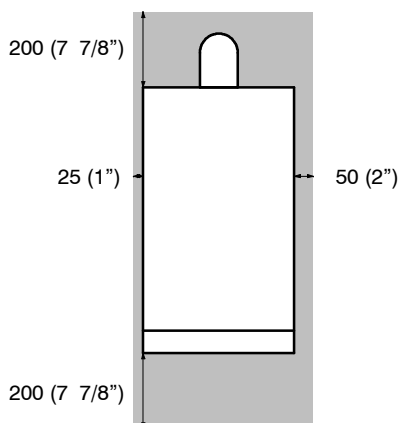

#### Bottom clearance

The bottom clearance, after installation, can be reduced to 20mm. However, 200mm must be available for servicing.

#### Front clearance

The minimum front clearance when built into a cupboard is 50mm (2") from the cupboard door. However 450mm (17 3/4") overall clearance is still required, with the cupboard door open, to allow for servicing.

#### Side and Rear Flue

a. Provided that the flue hole is cut accurately, e.g. with a core drill, the flue can be installed from inside the building where wall thickness does not exceed 600 mm (24").

Where the space into which the boiler is going to be installed is less than the length of flue required the flue must be fitted from the outside.

#### installation from inside ONLY

b. If a core boring tool is to be used inside the building the space in which the boiler is to be installed must be at least wide enough to accommodate the tool.

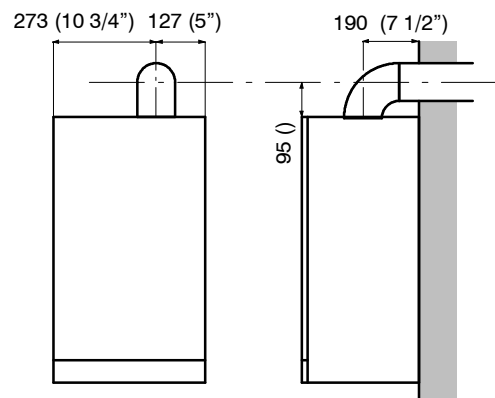

## GENERAL

### INTRODUCTION

**mini HE C24** and **mini HE C28** are wall mounted, low water content, balanced flue, condensing combination gas boilers.

Central heating (CH) output and domestic hot water (DHW) output are both fully modulating:

– between 10.2 (34 936) and 24.6\* (83 973) kW (btu/h) for model **mini HE C24**;

– between 12.1 (41 284) and 28.3\* (96 488) kW (btu/h) for model **mini HE C28**.

\* outputs with G31 (propane) feeding are slightly different. See section *Boiler Data* at page 4 for detailed figures.

Due to the high efficiency of the boiler a plume of water vapour will form at the terminal during operation.

The boilers are suitable for connection to fully pumped, pressurised sealed water systems ONLY.

A system bypass is not required when TRV's are fitted to **all** radiators (see Frame 5). The boiler incorporates an automatic bypass.

A circulating pump, pressure gauge, safety valve and heating expansion vessel are provided.

The CH flow temperature is controlled by a thermistor. In DHW mode the boiler modulates to sustain a nominal adjustable water flow temperature of 55 °C.

The boiler casing is of white painted mild steel with a drop-down controls access door.

The boiler temperature control is located behind the control panel door.

The main heat exchanger is made of copper.

The condensing heat exchanger (recuperator) and the DHW heat exchanger are stainless steel.

The system pipework must include drain cocks in appropriate places. Pipework may be taken downwards.

For upwards pipework installation an additional frame (optional) must be used (see frame 18).

### OPTIONAL EXTRA KITS

Programmer Kit fits neatly within the casing. Separate fitting instructions are included with the kit. Note. If using an alternative programmer read Frame 25 first.

#### Horizontal Concentric Extension Ducts

**Up to 2,7 m (8' 10") for all models.**

Other available kits are listed in frame 9.

### SAFE HANDLING

This boiler may require 2 or more operatives to move it to its installation site, remove it from its packaging base and during movement into its installation location. Maneuvering the boiler may include the use of a sack truck and involve lifting, pushing and pulling.

Caution should be exercised during these operations.

Operatives should be knowledgeable in handling techniques when performing these tasks and the following precautions should be considered:

- Grip the boiler at the base.
- Be physically capable.
- Use PPE as appropriate, e.g. gloves, safety footwear.

During all maneuvers and handling actions, every attempt should be made to ensure the following unless unavoidable and/or the weight is light.

- Keep back straight.
- Avoid twisting at the waist.

### mini HE – Installation & Servicing

- Avoid upper body/top heavy bending.
- Always grip with the palm of the hand.
- Use designated hand holds.
- Keep load as close to the body as possible.
- Always use assistance if required.

### DHW OPERATION

With no call for CH the boiler fires only when DHW is drawn off. When there is a call for CH, the heating system is supplied at the selected temperature until DHW is drawn off. The output is then directed by the diverter valve to heat the secondary heat exchanger and supply a maximum draw-off of:

**mini HE C24.** 10.1 (2.2) l/min (gpm) at 35 degree rise.

**mini HE C28** 11.7 (2.6) l/min (gpm) at 35 degree rise.

The nominal DHW temperature is 55 °C, but water drawn off when the boiler has been on for central heating may be hotter than this, for a short period of time.

### GAS SAFETY

#### Current Gas Safety (Installation and Use) Regulations or rules in force

The appliance is suitable only for installation in GB and IE and should be installed in accordance with the rules in force. In GB, the installation must be carried out by a CORGI Registered Installer. It must be carried out in accordance with the relevant requirements of the:

- Gas Safety (Installation and Use) Regulations
- The appropriate Building Regulations either The Building Regulations, The Building Regulations (Scotland), Building Regulations (Northern Ireland).
- The Water Fittings Regulations or Water byelaws in Scotland.
- The Current I.E.E. Wiring Regulations.

Where no specific instructions are given, reference should be made to the relevant British Standard Code of Practice.

In IE, the installation must be carried out by a Competent Person and installed in accordance with the current edition of I.S.813 "Domestic Gas Installations", the current Building Regulations and reference should be made to the current ETCI rules for electrical installation.

Detailed recommendations are contained in the following British Standard Codes of Practice:

- BS 5440:1** Flues (for gas appliances of rated input not exceeding 70 kW).
- BS 5440:2** Ventilation (for gas appliances of rated input not exceeding 70 kW).
- BS. 5449** Forced circulation hot water systems.
- BS. 5546** Installation of gas hot water supplies for domestic purposes (2nd Family Gases)
- BS 6700** Design, installation testing and maintenance of services supplying hot water for domestic use.
- BS. 6798** Installation of gas fired hot water boilers of rated input not exceeding 70 kW.
- BS. 6891** Low pressure installation pipes.

Health & Safety Document No. 635.

The Electricity at Work Regulations, 1989.

The manufacturers notes must NOT be taken, in any way, as overriding statutory obligations.

**IMPORTANT** These appliances are CE certificated for safety and performance. It is, therefore, important that no external control devices, e.g. flue dampers, economisers etc., are directly connected to these appliances unless covered by

## GENERAL GAS SUPPLY

these Installation and Servicing Instructions or as otherwise recommended by **Caradon Ideal Ltd.** in writing. If in doubt please enquire.

Any direct connection of a control device not approved by **Caradon Ideal Ltd.** could invalidate the certification and the normal appliance warranty. It could also infringe the Gas Safety Regulations and the above regulations.

### SAFE HANDLING OF SUBSTANCES

Care should be taken when handling the boiler insulation panels, which can cause irritation to the skin. No asbestos, mercury or CFCs are included in any part of the boiler in its manufacture.

### LOCATION OF BOILER AND FLUE OUTLET

The boiler must be installed on a flat and vertical wall, capable of adequately supporting the weight of the boiler and any ancillary equipment.

The boiler may be fitted on a combustible wall and insulation between the wall and the boiler is not necessary, unless required by the local authority.

**The boiler must not be fitted outside.**

#### Timber Framed Buildings

If the boiler is to be fitted in a timber framed building it should be fitted in accordance with the Institute of Gas Engineers document IGE/UP/7, 1998.

#### Bathroom Installations

The boiler may be installed in any room or internal space, although particular attention is drawn to the requirements of the current I.E.E. (BS.7671) Wiring Regulations and, in Scotland, the electrical provisions of the building regulations applicable in Scotland with respect to the installation of the boiler in a room or internal space containing a bath or shower.

For Ireland reference should be made to the current ETCI rules for electrical installations and I.S.813:2002

Where a room sealed appliance is installed in a room containing a bath or shower then the appliance and any electrical switch or appliance control utilising mains electricity should be so situated that it cannot be touched by a person using the bath or shower.

**Note.** It is not permissible to install a mains socket in a bathroom.

Where installation will be in an unusual location, special procedures may be necessary and BS 6798 gives detailed guidance on this aspect.

#### Compartment Installations

A compartment used to enclose the boiler should be designed and constructed specially for this purpose. An existing cupboard or compartment may be used, provided that it is modified for the purpose.

In both cases details of essential features of cupboard / compartment design, including air cupboard installation, are to conform to the following:

- BS 6798 (No cupboard ventilation is required – see “Air supply” for details)
- The position selected for installation MUST allow adequate space for servicing in front of the boiler.
- For the minimum clearances required for safety and subsequent service, see the wall mounting template and frame 2. In addition, sufficient space may be required to allow lifting access to the wall mounting plate.

The local gas supplier should be consulted, at the installation stage, in order to establish the availability of an adequate supply of gas. An existing service pipe must NOT be used without prior consultation with the local gas supplier. Natural gas boilers must be installed on a gas supply with a governed meter. A gas meter can only be connected by the local gas supplier or by a registered CORGI engineer.

Propane gas boilers MUST be installed with pipes, cylinders and pressure regulators fitted in accordance with BS.5482.1. Bulk tank installations MUST comply with the Home Office code of practice for storage of liquefied petroleum gas at fixed installations. The complete installation MUST be tested for gas soundness and purged as described in the above code.

The boiler is adjusted at the factory for use with the relevant supply gas. A working gas pressure equal to that stated in Table 1 MUST be available at the boiler inlet.

Where applicable, the appliance can be converted for G20–Natural Gas or G31 –Propane Gas by using the appropriate conversion kit.

**IMPORTANT** Installation pipes MUST be fitted in accordance with BS. 6891. In IE refer to I.S. 813.2002.

Pipework from the meter to the boiler MUST be of an adequate size, i.e. not less than 22 mm O.D. copper or 3/4” BSP iron.

### FLUE INSTALLATION REQUIREMENTS

The flue must be installed in accordance with the recommendations of BS. 5440–1 2000. In IE refer to I.S. 813.2002.

The following notes are intended for general guidance.

- 1 The boiler MUST be installed so that the terminal is exposed to external air.
- 2 It is important that the position of the terminal allows the free passage of air across it at all times.
- 3 Minimum acceptable spacing from the terminal to obstructions and ventilation openings are specified in Table 4.
- 4 Where the lowest part of the terminal is fitted less than 2m (6’6”) above a balcony, above ground or above a flat roof to which people have access then the terminal MUST be protected by a purpose designed guard. Ensure that the guard is fitted centrally.
- 5 Where the terminal is fitted within 850mm (34”) of a plastic or painted gutter or 450mm (18”) of painted eaves then an aluminium shield at least 750mm (30”) long should be fitted to the underside of the gutter or painted surface fitted centrally above the flue.
- 6 The air inlet/products outlet duct and the terminal of the boiler MUST NOT be closer than 25mm (1”) to combustible material. Detailed recommendations on the protection of combustible material are given in BS. 5440–1:2000. In IE refer to I.S. 813.2002.

**Table 4 – Balanced flue terminal position**

Terminal position	Minimum spacing
1 Directly below, above or along side of an openable window, air vent or other ventilation opening	300 mm (12”)
2 Below guttering, drain pipes or soil pipes	25 mm ( 1”)
3 Below eaves	25 mm ( 1”)
4 Below balconies or a car port roof	25 mm ( 1”)
5 From vertical drain pipes or soil pipes*	25 mm ( 1”)
6 From an internal or external corner or to a boundary along side the terminal	25 mm ( 1”)

## GENERAL

7	Above adjacent ground, roof or balcony level	300 mm (12")
8	From a surface or a boundary facing the terminal.	600 mm (24")
9	From a terminal facing a terminal	1200 mm (48")
10	From an opening in a car port (e.g. door or window) into dwelling	1200 mm (48")
11	Vertically from a terminal on the same wall	1500 mm (60")
12	Horizontally from a terminal on the wall	300 mm (12")

\* If the terminal is within 150mm of any vertical soil or drain pipe, an aluminium shield at least 400mm (15 3/4") long should be fitted equi-distant from the terminal and close to the pipe.

Vertical Terminals		
13	Above the roof pitch with roof slope of all angles.	300 mm (12")
	Above flat roof	300 mm (12")
14	From single wall face	600 mm (24")
	From corner wall faces	1000 mm (40")
Twin Flue Applications		
15	Centre distance between air inlet and flue outlet ducts	120mm (5") **

\*\* Where the twin flue ducts are positioned at or near the above minimum centres the wall sealing gaskets should be trimmed to allow them to fit flat to the wall. This should be done for both inside and outside wall gaskets

Terminals guards are available from boiler suppliers – ask for Tower Flue Guard, Model K6. In case of difficulty seek advice from:

Grasslin UK Ltd., Tower house, Vale Rise, Tonbridge, Kent TN9 1TB Tel. +44 (0) 1732 359 888 Fax No. +44 (0) 1732 354 455 www.tfc-group.co.uk

**IMPORTANT** It is absolutely **ESSENTIAL** to ensure, in practice, that products of combustion discharging from the terminal cannot re-enter the building or any other adjacent building through ventilators, windows, doors other sources of natural air infiltration, or forced ventilation / air conditioning.

If this should occur the appliance **MUST** be turned **OFF**, labelled as "unsafe" until corrective action taken.

### AIR SUPPLY

It is **NOT** necessary to have a purpose-provided air vent in the room or internal space in which the boiler is installed. Neither is it necessary to ventilate a cupboard or compartment in which the boiler is installed, due to the low surface temperatures of the boiler casing during operation; therefore the requirements of BS6798, Clause 12, BS 5440:2 and in IE I.S. 813:2002 may be disregarded.

## WATER CIRCULATION SYSTEM

The boilers are designed for connection to pressurised, fully pumped, sealed water central heating systems **ONLY**. The domestic hot water (DHW) calorifier is incorporated within the combi boiler and only requires connection to the mains water supply.

### Additional Pumps.

The boiler is supplied with an integral circulating pump. If the boiler is to be used in conjunction with any additional circulating pumps, please contact the Technical Helpline for advice on application.

### IMPORTANT

A minimum length of 1m of copper pipe **MUST** be fitted to both flow and return connections from the boiler before connection to any plastic piping.

Ensure that the mains water supply pressure is adequate to provide the required DHW flow rate. Refer to Table 1 on page 4.

The central heating system should be in accordance with BS. 6798 and, in addition, for smallbore and microbore systems BS. 5449.

The domestic hot water system should be in accordance with BS. 5546 and BS. 6700.

Copper tubing to BS 2871:1 is recommended for water carrying pipework and **MUST** be used for pipework carrying potable water.

Any soldered joints on potable water pipework **MUST NOT** be made with solder containing lead.

Ancillary pipework not forming part of the useful heating surface should be lagged to prevent heat loss and any possible freezing – particularly where pipes run through roof spaces or ventilated underfloor spaces.

Draining taps should be at least 1/2" BSP nominal size and be in accordance with BS 2879.

## WATER TREATMENT

### Central Heating

Antifreeze fluid, corrosion and scale inhibitor fluids suitable for use with boilers having copper heat exchangers may be used in the central heating system.

### IMPORTANT

**The application of any other treatment to this product may render the guarantee of Caradon Ideal Limited INVALID.**

Caradon Ideal Limited recommend Water Treatment in accordance with the Benchmark Guidance Notes on Water Treatment in Central Heating Systems.

Caradon Ideal Limited recommend the use of Fernox, GE Betz Sentinel or Salamander water treatment products, which must be used in accordance with the manufacturers instructions.

### Notes.

1. It is most important that the correct concentration of the water treatment products is maintained in accordance with the manufacturers' instructions.
2. If the boiler is installed in an existing system any unsuitable additives **MUST** be removed by thorough cleansing. BS 7593:1992 details the steps necessary to clean a domestic heating system.
3. In hard water areas, treatment to prevent lime scale may be necessary – however, the use of artificially softened water is **NOT** permitted.
4. Under no circumstances should the boiler be fired before the system has been thoroughly flushed.

## GENERAL

### Domestic Hot Water

In hard water areas where mains water can exceed 200ppm Total Hardness (as defined by BS 7593:1993 Table 2) a scale reducing device should be fitted into the boiler cold supply within the requirements of the local water company. The use of artificially softened water, however, is NOT permitted.

Caradon Ideal Limited recommend the use of Fernox Qantomat, GE Betz Sentinel Combiguard and Calmag CalPhos I scale reducing devices, which must be used in accordance with the manufacturers' instructions.

For further information contact:

Fernox  
Cookson Electronics  
Forsyth Road  
Sheerwater  
Woking  
Surrey  
GU21 5RZ  
+44 (0) 1799 550811

Calmag Ltd.  
Unit 4–6 Crown Works  
Bradford Road  
Sandbeds  
Keighley  
West Yorkshire  
BD20 5LN  
+44 (0) 1535 210320

Salamander (Eng) Ltd  
Reddicap Trading Estate  
Sutton Coldfield  
West Midlands  
B75 7BY

GE Betz  
Sentinel Division  
Foundry Lane  
Widnes  
Cheshire  
WA8 8UD

+44 (0) 121 378 0952

+44 (0) 151 420 9563

## 3 ELECTRICAL SUPPLY

**Warning.** This appliance must be efficiently earthed.

Wiring external to the appliance MUST be in accordance with the current I.E.E. (BS.7671) Wiring Regulations and any local regulations which apply. For Ireland reference should be made to the current ETCI rules for electrical installations.

The point of connection to the mains should be readily accessible and adjacent to the boiler, except for bathroom installations where the point of connection to the mains MUST be situated outside of the bathroom.

**Note.** Where a room sealed appliance is installed in a room containing a bath or shower then the appliance and any electrical switch or appliance control utilising mains electricity should be so situated that it cannot be touched by a person using the bath or shower.

## 4 SEALED SYSTEM REQUIREMENTS Central Heating

*Note. mini HE boilers are suitable for fully pumped pressurised sealed systems only.*

### REQUIREMENTS

#### 1 General

The installation must comply with the requirements of BS. 6798 and BS. 5449.

#### 2 Flow Temperature

The installation should be designed to work with flow temperatures of up to 90 °C.

#### 3 Working Pressure

All components of the system must be suitable for a working pressure of 3 bar (45 lb/in<sup>2</sup>) and temperature of 110 °C. Extra care should be taken in making all connections so that the risk of leakage is minimised.

The following components are incorporated within the appliance:

- Circulating pump.
- Safety valve; with a non-adjustable pre-set lift pressure of 3 bar (45lb/in<sup>2</sup>).
- Pressure gauge; covering a range of 0–4 bar.
- 6 litre expansion vessel; with an initial charge pressure of 0.7 bar (10.5 lb/in<sup>2</sup>).

For further details refer to BS.5449:1 and the British Gas Corporation publication 'Specifications for Domestic Central Heating and Hot Water'.

#### 4 Filling the system

Fill the system through a temporary hose connection from a draw-off tap supplied from a service pipe under mains pressure. Where the mains pressure is excessive a pressure reducing valve shall be used to facilitate filling.

When installing the filling connection provided with the boiler an additional WRAS approved valve must be fitted to the mains water supply upstream of the double check valve to fully comply the Water Regulations

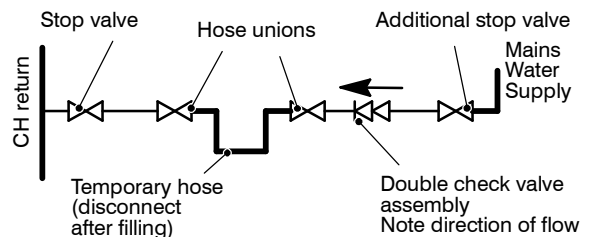

#### System filling and make-up

Proceed with the following:

- Thoroughly flush out the whole of the system with cold water before fitting the boiler.
- Fill and vent the system until the pressure gauge registers 1.5 bar (22 lb/in<sup>2</sup>). Examine for leaks.
- Release water from the system until a pressure of 1 bar (15 lb/in<sup>2</sup>) is reached.  
**To avoid getting debris on the valve seat, do not use the safety valve to do this.**
- Light the boiler and heat the system to the maximum working temperature. Examine for leaks.
- Turn off the boiler and drain the system while still hot.
- Refill and vent the system.
- Re-pressurise the system to the desired charge pressure (see Table 5).

## GENERAL

Table 5			
System charge pressure (bar)	0.5	0.7	1.0
Safety valve setting	3.0		
Vessel pre-charge pressure (bar)	0.7		
System volume (litres)	Volume of expansion vessel in addition to 6 litre unit fitted to boiler		
75	–	–	–
100	0.3	0.8	1.4
125	1.8	2.5	3.2
150	3.4	4.2	5.0
175	5.0	6.0	7.0
200	6.5	7.6	8.7
225	8.1	9.3	10.6
250	9.6	11.1	12.4
275	11.2	12.8	14.3
300	12.8	14.5	16.1
Multiply this factor by system volume and deduct 6 litres to obtain size of additional vessel for other system volumes.	0.063	0.069	0.074

### 5 Size of expansion vessel

For the system water expansion to be contained by the 6 litre expansion vessel the cold system volume must not exceed:

96 litres when pressurised to 0.5 bar (cold)

88 litres when pressurised to 0.7 bar (cold)

81 litres when pressurised to 1.0 bar (cold)

If the pressure exceeds 2.65 bar when the boiler is up to temperature with all radiators in use then an additional expansion vessel **MUST** be installed on the return pipework.

For expansion volumes see Table 5.

Guidance on vessel sizing is given in BS 7074:1 and BS 5449

For IE refer to the current edition of I.S. 813.

### 6 Hydraulic Loss

#### Remaining pump capacity

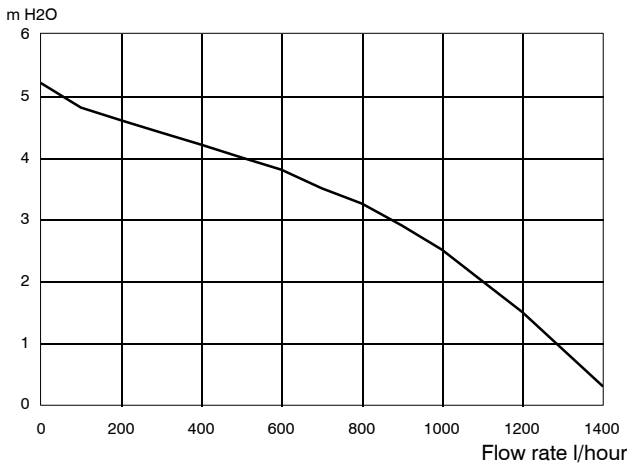

### 7 Draining the system

Draining taps **MUST** be located in accessible positions to permit the draining of the whole central heating system, including the central heating side of the boiler. The taps should be at least 1/2" BSP nominal size and be in accordance with BS 2879.

## 5 BOILER CONTROL INTERLOCKS

### Thermostatic radiator valves.

**Caradon Ideal Ltd.** support the recommendations made by leading manufacturers of domestic heating controls that heating systems utilising full thermostatic radiator valve control of temperature in individual rooms should also be fitted with a room thermostat controlling the temperature in a space served by radiators not fitted with such a valve as stated in BS5449. Such an arrangement will provide for a more efficient control of the environment and will also avoid the continuous running of the circulation pump during programmed heating ON periods, saving electrical energy.

It is therefore strongly recommended that, when thermostatic radiator valves are used, the space heating temperature control over a living/dining area or a hallway, having a heat requirement of at least 10% of the boiler output, is achieved using a room thermostat whilst other rooms are individually controlled by thermostatic radiator valves as stated in BS5449.

For further information refer to “Good Practise Guide 143” a publication of the energy efficiency office, available from the building research establishment Garston Watford WD2 7JR tel: +44 (0) 1923 664258

The boiler is fitted with an automatic internal bypass. No further system bypass is required.

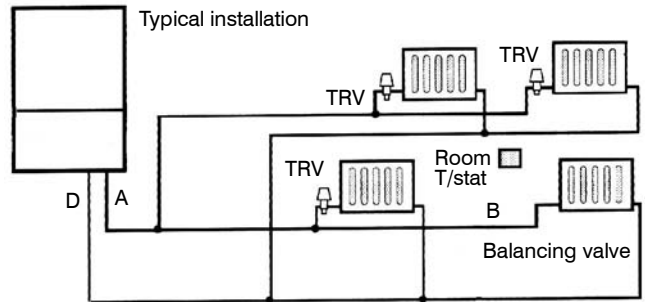

## 6 DOMESTIC HOT WATER REQUIREMENTS

- 1 The domestic hot water service must be in accordance with BS 5546 and BS 6700.
- 2 For the minimum and maximum working pressures of the **mini HE C24** and **mini HE C28** domestic hot water circuit refer to Table 1, page 4.
- 3 The cold water supply pipe should be flushed before fitting the boiler.
- 4 The boilers are suitable for connection to most types of washing machine and dishwashing appliances.

- 5 When connecting to suitable showers, i.e. those designed for modulating domestic hot water, ensure that:
  - a. The cold inlet to the boiler is fitted with an approved anti-vacuum or syphon non-return valve.
  - b. Hot and cold supplies are of equal pressure.
- 6 Hard water areas  
In areas where the water is 'hard' it is recommended that a proprietary scale-reducing device is fitted into the boiler cold supply, within the requirements of the local water company.

**7 BOILER WATER CIRCUIT DIAGRAM**

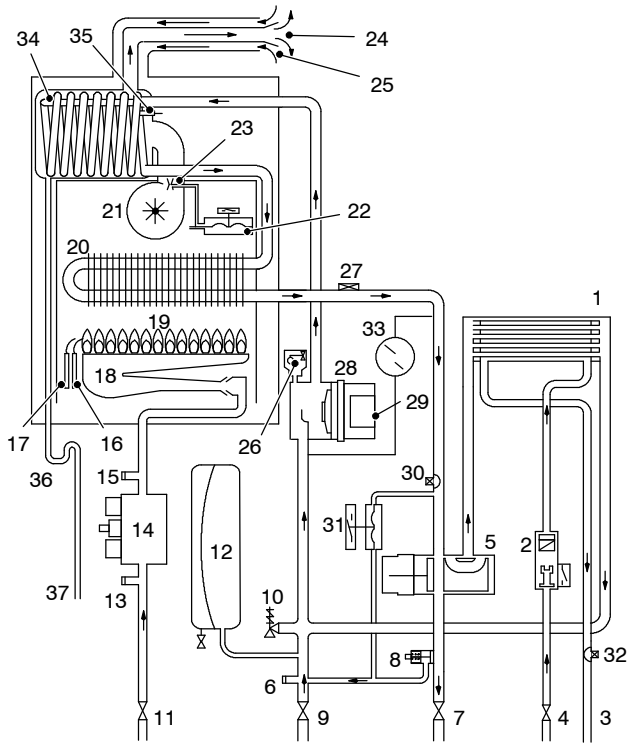

- 1 Domestic hot water (DHW) heat exchanger
- 2 Domestic hot water (DHW) flow switch
- 3 Domestic hot water (DHW) outlet pipe
- 4 Domestic cold water inlet cock
- 5 Three-way diverter valve
- 6 Main circuit drainage cock

- 7 Central heating flow cock
- 8 By-pass valve
- 9 Central heating (CH) return cock
- 10 3 bar pressure relief valve
- 11 Gas cock
- 12 Expansion vessel
- 13 Gas valve inlet pressure tap
- 14 Modulating gas valve
- 15 Burner pressure tap
- 16 Flame detection electrode
- 17 Ignition electrodes
- 18 Burner
- 19 Combustion chamber
- 20 Primary heat exchanger
- 21 Fan
- 22 Air pressure switch
- 23 Venturi device
- 24 Flue outlet pipe
- 25 Air intake pipe
- 26 Automatic air vent
- 27 Overheat thermostat
- 28 Pump
- 29 Pump vent plug
- 30 Water circuit temperature probe
- 31 CH flow switch
- 32 DHW temperature probe
- 33 CH circuit temperature/pressure gauge
- 34 Recuperator
- 35 Flue thermostat
- 36 Condensate trap
- 37 Condensate drain pipe

# INSTALLATION

**INSTALLATION**

## 8 BOILER ASSEMBLY – Exploded View

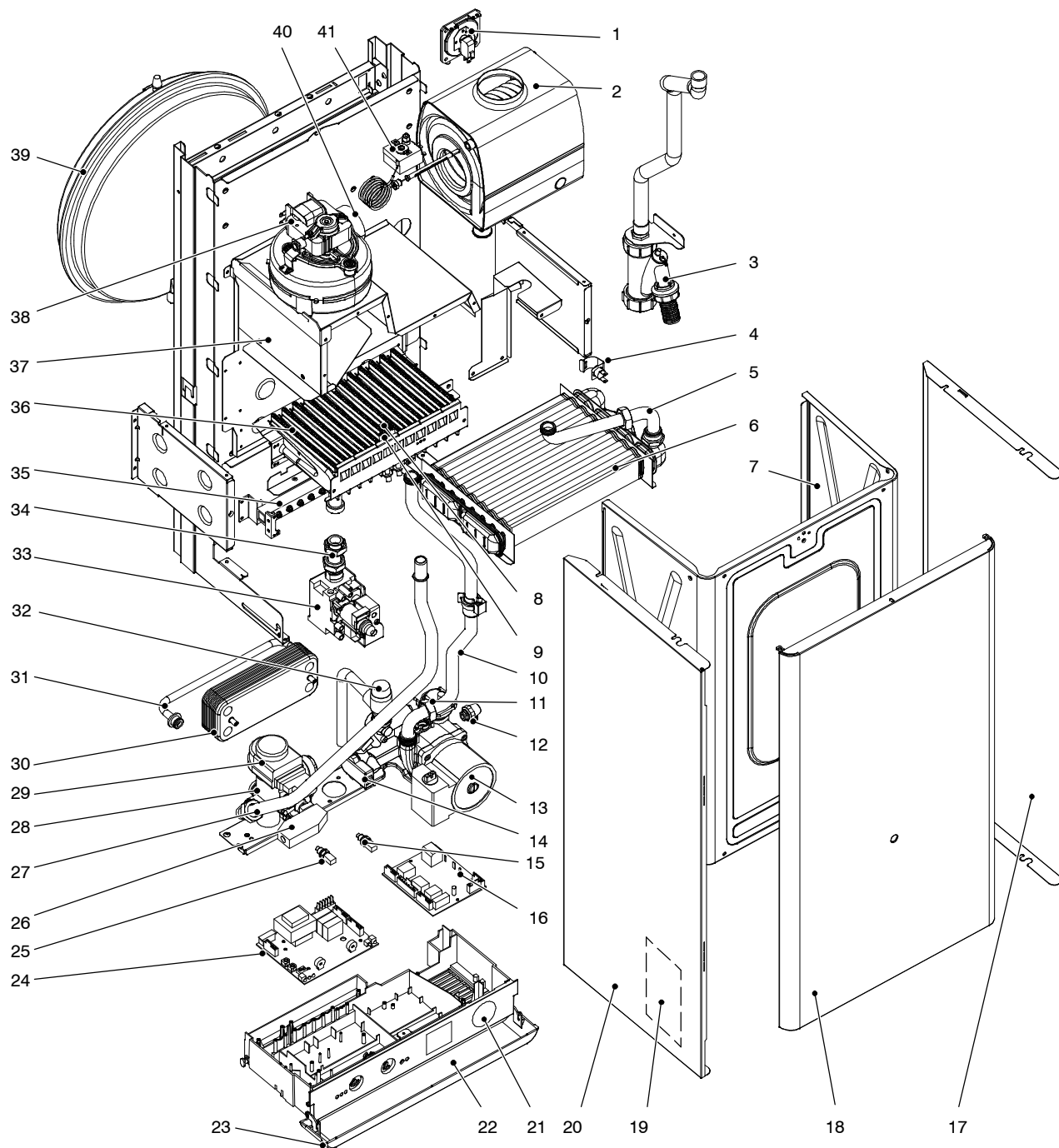

- |   |  |                                |
|---|--|--------------------------------|
| 1 Air pressure switch                               | 14 DHW flow switch                     | 28 Return manifold             |
| 2 Recuperator                                       | 15 DHW Thermistor                      | 29 3 way diverter valve        |
| 3 Condensate trap                                   | 16 Ignition pcb                        | 30 DHW heat exchanger          |
| 4 Overheat thermostat                               | 17 Right hand panel                    | 31 Bypass pipe                 |
| 5 Condensing to main heat exchanger connection pipe | 18 Boiler front panel                  | 32 3 bar pressure relief valve |
| 6 Primary heat exchanger                            | 19 Appliance data badge (inside)       | 33 Gas valve                   |
| 7 Inner case cover                                  | 20 Left hand panel                     | 34 Gas valve outlet pipe       |
| 8 Flame detection electrode                         | 21 CH circuit pressure gauge           | 35 Injector manifold           |
| 9 Ignition electrodes                               | 22 Model identification & instructions | 36 Burner                      |
| 10 Heat exchanger return pipe                       | 23 Control panel door                  | 37 Flue hood                   |
| 11 Auto air vent                                    | 24 Main control pcb                    | 38 Fan                         |
| 12 Main circuit drainage cock                       | 25 CH Thermistor                       | 39 Expansion vessel            |
| 13 Pump   | 26 CH flow switch                      | 40 Venturi                     |
|   | 27 Heat exchanger flow pipe            | 41 Flue thermostat             |

## INSTALLATION

### 9 UNPACKING

The boiler is supplied fully assembled in one pack A, together with a standard flue assembly for lengths up to 960 mm (37" 3/4), rear or side flue outlet, in pack B.

Unpack and check the contents.

#### Pack A contents

- A The boiler.
- B Hardware pack
- C Wall mounting plate
- D Wall mounting template
- E User's, Installation & Servicing instructions.
- F Filling loop assembly

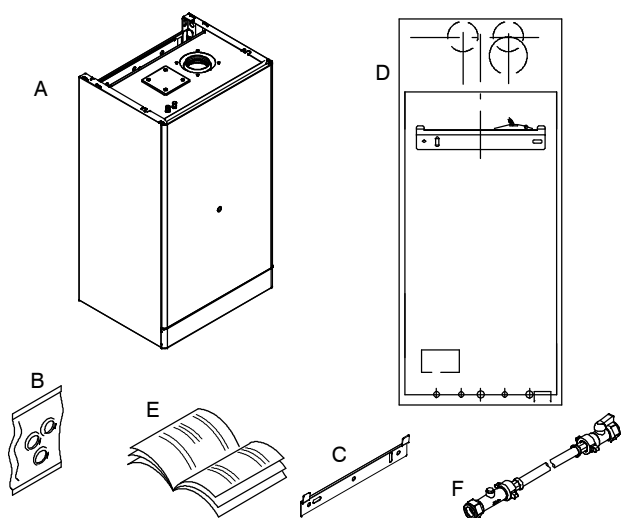

#### Hardware pack contents

- 22 mm CH connection pipe – 2 off.
- 22 mm Gas supply connection pipe – 1 off.
- 15 mm DHW cold inlet connection pipe – 1 off.
- 15 mm DHW hot outlet connection pipe – 1 off.
- 1/2" connection nut – 2 off.
- 1/2" sealing washer – 3 off.
- 3/4" sealing washer – 6 off.
- 3/4" Gas supply isolating valve – 1 off.
- 3/4" CH circuit isolating valve – 2 off.
- 1/2" DHW cold inlet isolating valve – 1 off.

#### Pack B contents

- G Air intake pipe  $\varnothing$  100 mm (4"), flue pipe  $\varnothing$  60 mm (2" 3/8) with terminal grille assembly

- H Centring spring
- I Turret–air pipe gasket
- J Flue pipe gasket
- K Boiler–turret gasket
- L Flue turret
- M Self tapping screws 4,8x13 – 4 off
- N Wall finishing gasket – internal (plastic)
- O Wall finishing gasket – external (rubber)

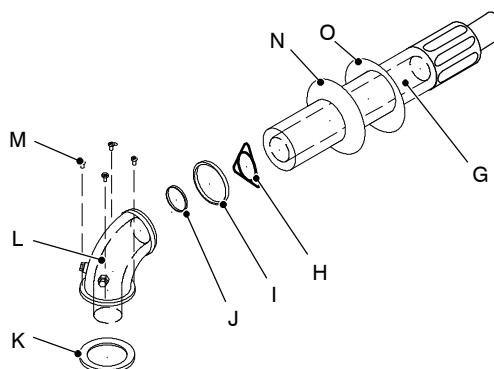

Optional extras, if ordered, are available in separate boxes.

- Electronic programmer kits – 24 hrs & 7 day
- Extension duct kit pack D ( $\varnothing$  60/100)
- Flue support kits  $\varnothing$  80, 100, 125
- Vertical outlet flue kit with elbow ( $\varnothing$  60/100)
- 90° Elbow kit ( $\varnothing$  60/100)
- 45° Elbow kit ( $\varnothing$  60/100)
- Roof flue kit ( $\varnothing$  80/125)
- Universal weather collar (for roof flue kit)
- Flat roof weather collar (for roof flue kit)
- Extension duct kit ( $\varnothing$  80/125)
- 90° Elbow kit ( $\varnothing$  80/125)
- 45° Elbow kit ( $\varnothing$  80/125)
- Condense drain vertical ( $\varnothing$  80/125)
- Twin pipe kit ( $\varnothing$  80) with air and flue terminals
- Extension duct kit ( $\varnothing$  80)
- 90° Elbow kit ( $\varnothing$  80) male–female
- 45° Elbow kit ( $\varnothing$  80) male–female
- Vertical condense drain ( $\varnothing$  80)
- Horizontal condense drain ( $\varnothing$  80)
- Condense trap
- Stand–off bracket
- Natural gas to LPG conversion kit
- LPG to natural gas conversion kit
- Condensate pump kit

### 10 PACKAGING

To unpack the boiler refer to the instructions on carton end flap.

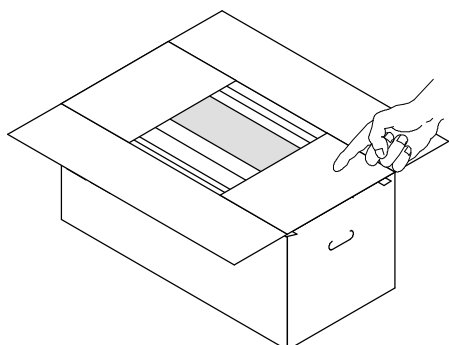

## INSTALLATION

### 11 FITTING THE FLUE SYSTEM

The minimum and maximum equivalent length for co-axial pipes  $\varnothing$  60–100 and  $\varnothing$  80–125 mm are given in Table 6.

The minimum and maximum equivalent length for  $\varnothing$  80 mm twin pipe systems are given in Table 7.

For roof flue systems having a flue length greater than 3m and all twin pipe systems, a condensate drain kit must be fitted at the lowest point in the system. See the list of optional extras (frame 9) for available drain kits.

Refer to the assembly instructions contained within the chosen flue kit packaging for the correct assembly and installation.

The horizontal sections of flue pipes must have a slope not less than 1.5 deg. (25 mm per metre) towards the boiler.

In the flue kit of pack B the flue pipe is angled within the air duct therefore the air duct must be horizontally installed.

In the case that one or more extensions need to be used they must be adequately supported so that there is no sag in the flue pipe and a minimum fall of 1.5 deg. (25 mm per metre) over the whole length towards the boiler is ensured.

	Minimum	Maximum
Co-axial 60–100	0.3 (11.8")	2.7 (8' 10")
Co-axial 80–125	0.5 (19.7")	8.5 (27' 10")

#### Co-axial Flue kits.

Horizontal.

For calculation of total flue length, the distance MUST be measured from the centreline of the concentric elbow to the end of the terminal.

Vertical outlet

For calculation of total flue length, the distance MUST be measured from the centreline of the outlet connector at the boiler top panel to the end of the terminal grille.

For each additional 45° and 90° flue bend used, the maximum permissible length of flue system must be reduced by 1 m or 1,5 m respectively.

#### Cutting lengths of flue and air ducts

Measure the wall thickness and, when using a side outlet, the gap between the inner wall and the boiler side casing. Use the following chart to calculate the cutting length of air duct.

Mark the air duct making reference on the groove.

Cut the flue duct at the same level of the air duct edge.

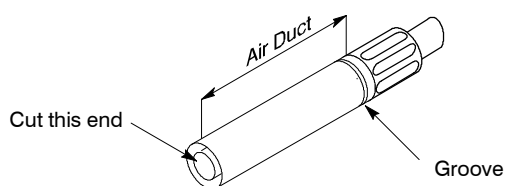

Horizontal Concentric	
<b>Air duct</b>	
Rear Outlet	Wall thickness + 125 mm
Rear outlet+ Stand-off	Wall thickness + 160 mm
Side Outlet – RH	Wall thickness + Gap + 62 mm
Side Outlet – LH	Wall thickness + Gap + 208 mm

#### Twin pipe flue kits

For calculation of total flue length, the distance MUST be measured from the centreline of the flue duct/air duct connection to the end of the flue outlet grille/air inlet duct.

For each additional 45° M&F and 90° M&F flue bend used, the maximum permissible length of flue system must be reduced by 0,9m or 1,65m respectively.

Two restrictors with different sizes are supplied with the twin pipe kit and have to be installed between the boiler and the air intake adapter as indicated in the following picture.

The restrictor to be used and the lengths of allowable equivalent flue outlet / air inlet ducts are indicated in Table 7 and in the following graph.

The restrictor size is marked on its body.

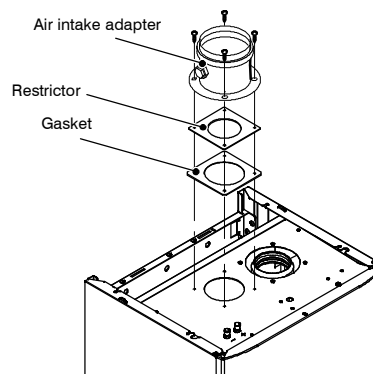

Equivalent pipe length (air duct + flue duct)	Restrictor
Between 1 (39") and 15 m (49' 2")	$\varnothing$ 50 mm
More than 15 m (49' 2") up to 30 m (98' 5")	$\varnothing$ 55 mm

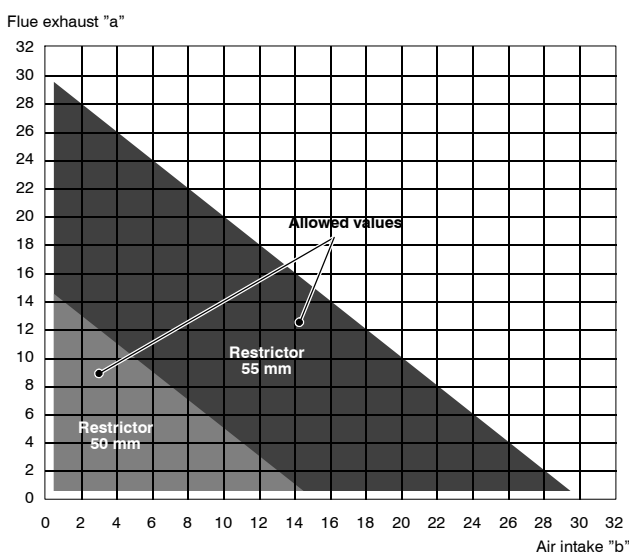

## INSTALLATION

### Cutting lengths of flue and air ducts

Measure the wall thickness and, when using a side outlet, the gap between the inner wall and the boiler side casing. Use the following chart to calculate the cutting lengths of both flue and air ducts.

Mark the air duct and flue duct making reference on the groove.

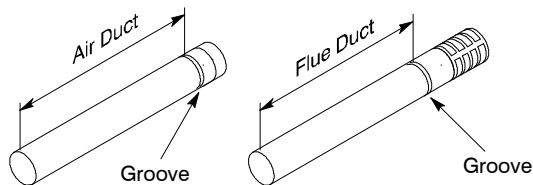

Twin Pipe	
<b>Air duct</b>	
Rear Outlet	Wall thickness + 130 mm
Rear outlet+ Stand-off	Wall thickness + 165 mm
Side Outlet – RH	Wall thickness + Gap + 187 mm
Side Outlet – LH	Wall thickness + Gap + 93 mm
<b>Flue Duct</b>	
Rear Outlet	Wall thickness + 130 mm
Rear outlet+ Stand-off	Wall thickness + 165 mm
Side Outlet – RH	Wall thickness + Gap + 67 mm
Side Outlet – LH	Wall thickness + Gap + 213 mm

## 12 REAR FLUE ASSEMBLY

Legend

- 1 Wall finishing gasket – external (rubber)
- 2 Self tapping screw 4,2x13
- 3 Flue turret
- 4 Boiler–turret gasket
- 5 Flue pipe gasket
- 6 Turret–air pipe gasket
- 7 Centring spring
- 8 Air/flue pipe with terminal grille assembly
- 9 Wall finishing gasket – internal (plastic)

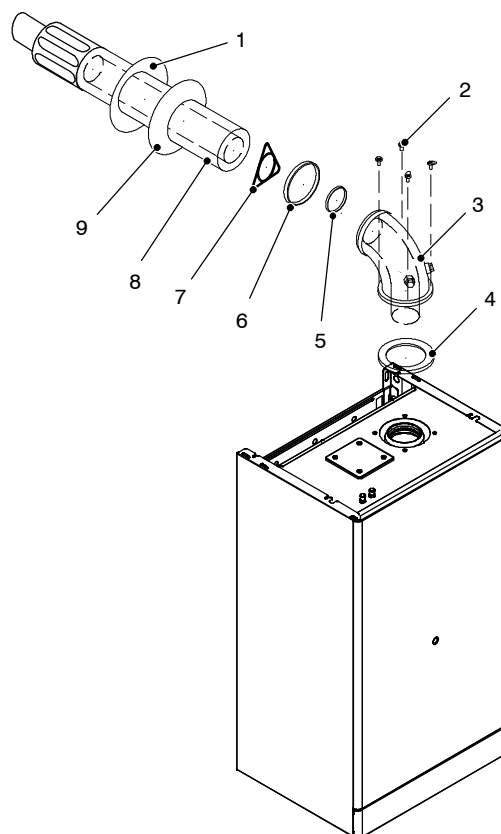

## 13 WALL MOUNTING TEMPLATE (rear flue)

### IMPORTANT

Detailed installation steps are given directly on the wall mounting template

- 1 Tape the template into the selected position.
- 2 Ensure squareness by hanging a plumbine.
- 3 Mark onto the wall the following:
  - a. the wall mounting plate screw positions
  - b. the position of the flue duct.  
(Mark the centre of the hole as well as the circumference)
- 4 Remove the template from the wall

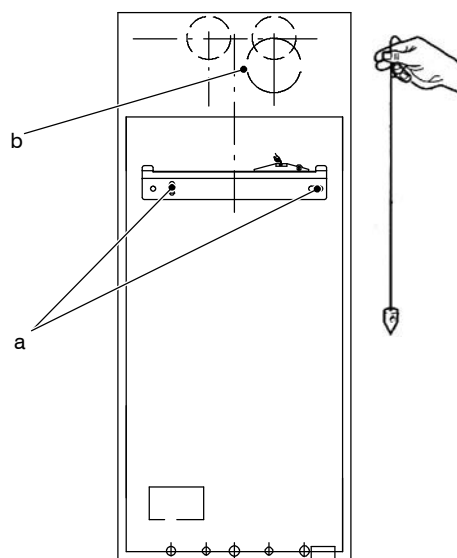

## 14 WALL MOUNTING TEMPLATE (side flue)

### IMPORTANT

Detailed installation steps are given directly on the wall mounting template

- 1 Tape the template into the selected position.
- 2 Ensure squareness by hanging a plumbine.
- 3 Mark onto the wall the following:
  - a. the wall mounting plate screw position
  - b. Extended the centre line as shown.
 Mark the flue ductcentre from the corner (see diagram and template)

**Note.** mark the centre of the hole as well as the circumference.  
If extension duct kit pack D has to be used, the pipes must have the correct slope as detailed in frame 11.

- 4 Remove the template from the wall

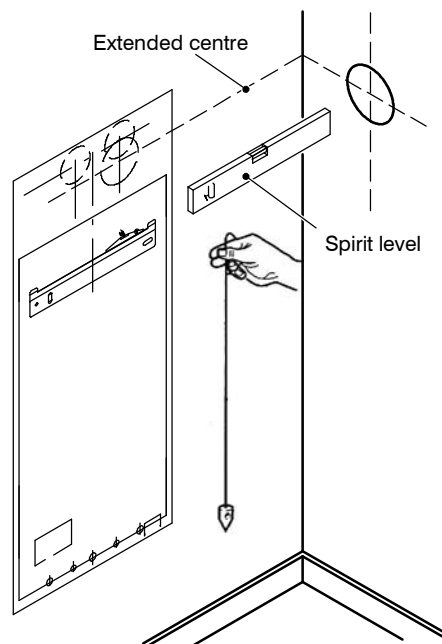

## 15 DRILLING THE WALL Rear flue shown

### IMPORTANT

Ensure that, during the cutting operation, masonry falling outside the building does not cause damage or personal injury.

- 1 Cut the flue hole (preferably with a 5" core boring tool), ensuring that the hole is square to the wall.
- 2 Drill the fixing holes with an 8mm (5/16") masonry drill. Fit suitable wall plugs (not provided).

**Note.** If the terminal is to be sited within 25–40 mm of a corner or vertical pipe (refer to Table 4) then the hole **MUST** be accurately cut and the rubber weather seal trimmed.

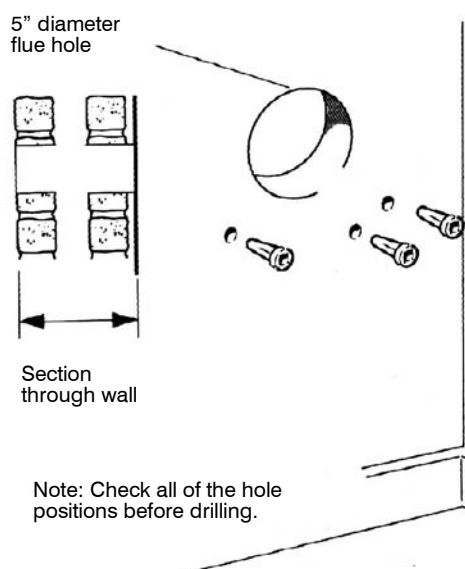

## 16 FITTING THE WALL MOUNTING PLATE

Refer to frame 18 for service connections.

Fit the wall mounting plate

### Directly to the wall

- Offer up wall mounting plate.
- Screw through the fixing holes using 3 off no. 14x2" screws (not provided).
- Check alignment with spirit level.
- Tighten screws.

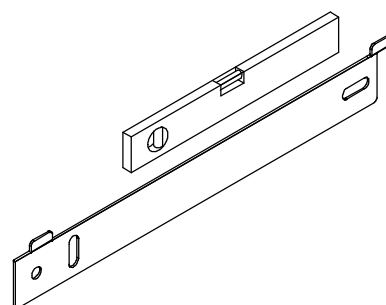

## 17 MOUNTING THE BOILER

Lift the boiler onto the wall mounting plate locating the bar at the rear of the back panel assembly into the bracket.

As added protection, the boiler should be lifted with the lower polystyrene packaging in place.

Lower the boiler into position.

Remove the lower packaging. Remove the front and side panels (refer to frame 22) and strip off the protective coating. The panels may be placed to one side and re-fitted when the installation is complete.

**Note.** Before fitting the flue system, fill the condensate trap within the boiler by pouring a cupful of water into the flue outlet A. Take care to ensure that the water is only poured into the flue outlet, and does not spill into the boiler casing.

Fit the flue system referring to the instructions contained with the kit.

Make good the internal wall surface using the seal provided.

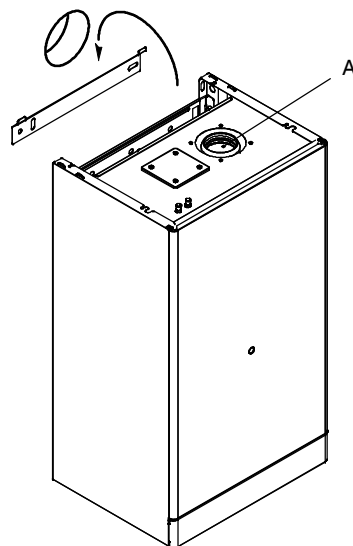

## 18 CONNECTIONS

Fit the service valves washers and tail pipes as shown.

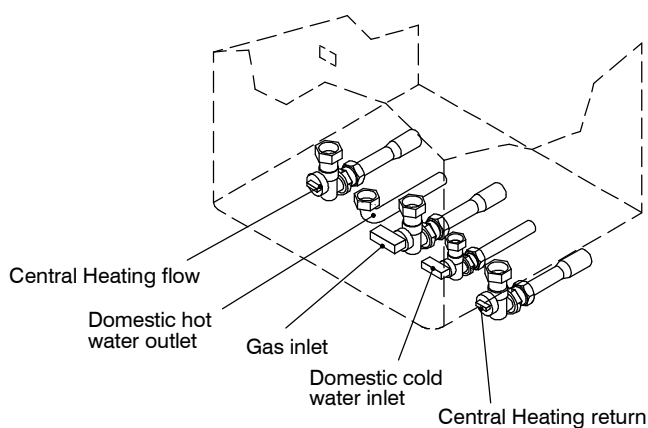

Connect to the tail pipes by proprietary fittings.

The pipework may be directed down or through the rear wall as required.

The pipework may be directed upwards by using the optional stand off bracket kit. See illustration for upward pipework routing

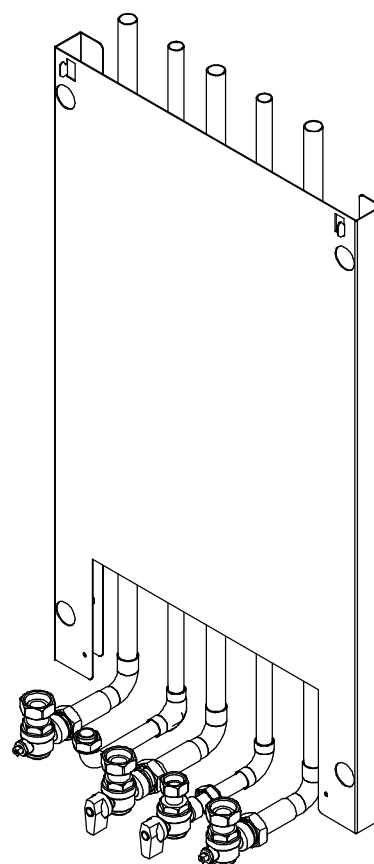

## 19 SAFETY VALVE DRAIN

The discharge pipe should be positioned so that the discharge of water or steam cannot create a hazard to the occupants of the premises or damage to electrical components and wiring.

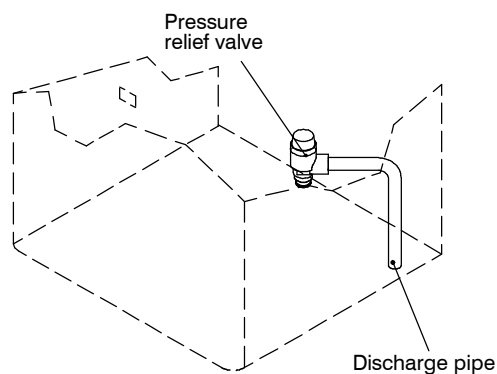

## 20 CONDENSATE DRAIN

Refer also to the British Gas document: "Guidance Notes for the installation of Domestic Gas Condensing Boilers" (1989).

The condensate drain provided on the boiler must be connected to a drainage point, preferably within the building.

The boiler includes a trap that prevents combustion products entering the drain. However an additional trap with a seal of at least 75 mm and an air break between the traps is required if the condensate drain pipe is connected to sanitary pipework.

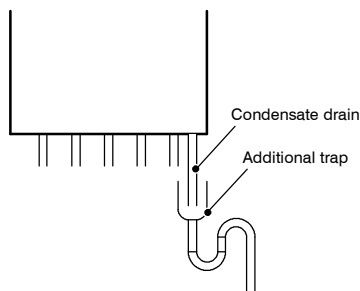

The length of the condensate pipe should be kept at minimum and must be arranged so that obstruction (e.g.

through freezing) of external drainage pipework does not give rise to spillage within the dwelling.

If a part of the drainpipe runs externally this part should be kept as short as possible and protected to reduce the risk of freezing.

### IMPORTANT

If excessive external pipework cannot be avoided an additional condensate removal pump (available as an option) and insulation are recommended to prevent possible freezing.

The drain outlet on the boiler is a 25 mm o.d. plastic pipe. This size must not be reduced below 21.5mm o.d. (standard overflow pipe) in any part of its length.

All pipework and fittings in the condensate drain system must be made of plastic. No other materials may be used.

To avoid condensate being trapped:

- the drainpipe should be run with a fall of at least 2.5° (45 mm/m) away from the boiler;
- the number of bends and joints should be kept at minimum;
- the drainpipe should be adequately fixed to prevent pipe sagging.

## 21 ELECTRICAL CONNECTIONS

**Warning. This appliance MUST be efficiently earthed**

A mains supply of 230 V ~ 50 Hz is required.

Mains wiring should be 3 core PVC insulated flexible cord NOT LESS than 0.75 mm<sup>2</sup> (24 x 0.2mm) and to BS. 6500, Table 16. (0.5mm<sup>2</sup> flex is not acceptable – for mechanical, not electrical reasons.)

Mains wiring external to the boiler MUST be in accordance with the current I.E.E. (BS7671) Wiring Regulations and any local regulations.

For Ireland reference should be made to the current ETCI rules for electrical installations.

The supply connection is intended to be made via a double pole switch having a 3 mm (1/8") contact separation in both poles, serving only the boiler and system controls. A 3 pin UNSWITCHED socket may, alternatively, be used.

The fuse rating should be 3 A.

**For external controls wiring see frame 25.**

**Note: the switch contacts of any external programmer, room or frost thermostat must be volt free.**

**Connecting a switched live feed to external controls terminal block may be dangerous and will result in serious damage to the boiler.**

## 22 ELECTRICAL CONNECTIONS

### Incoming mains wiring detail

To gain access to the power supply and external controls terminal blocks:

- 1 Remove the screws A and the front panel of the case.

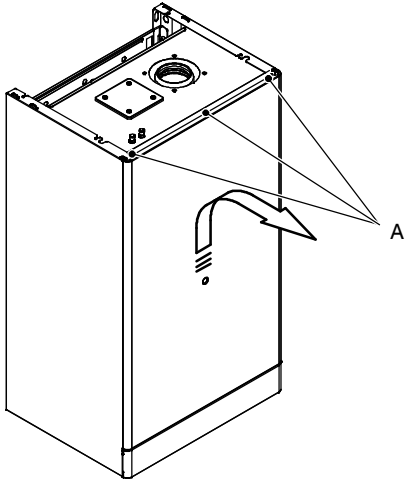

- 2 Remove the screws B.
- 3 Loosen the screws C.

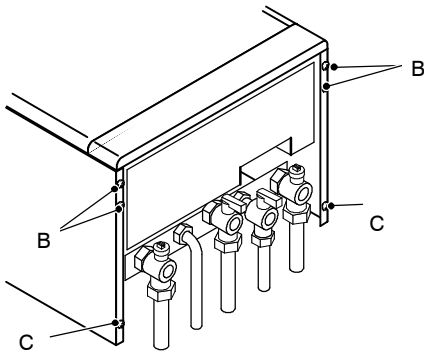

- 4 Remove the side panels or move the lower part of the side panels and pull the control panel.

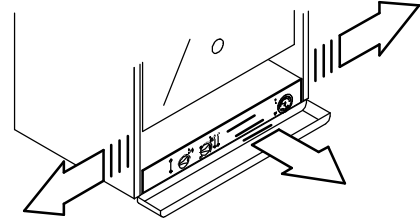

When completely pulled out, the panel can rotate 45° downwards to facilitate the operations on the internal parts.

- 5 Loosen the screws D and remove the service panel.

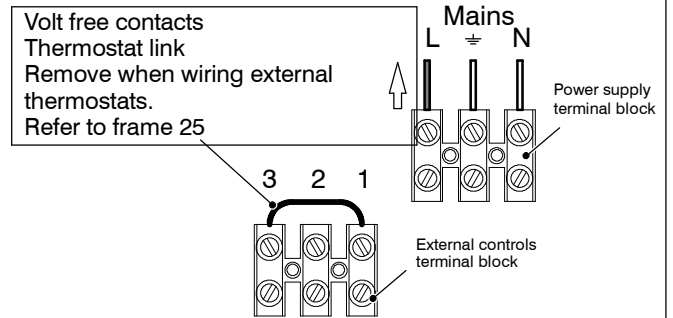
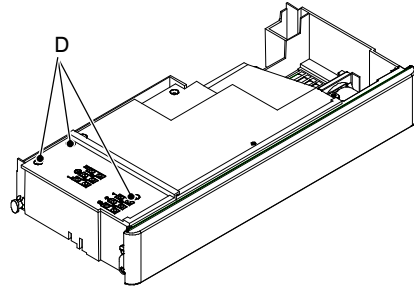

*Note: Ensure that the lengths of the current conductors are shorter than the earth conductor so that if the cable slips in its anchorage the current carrying conductors become taut before the earth conductor.*

23 PICTORIAL WIRING  
mini HE C24, mini HE C28

Wiring diagram for boiler equipped with full sequence ignition device type: Bertelli & Partners FM30

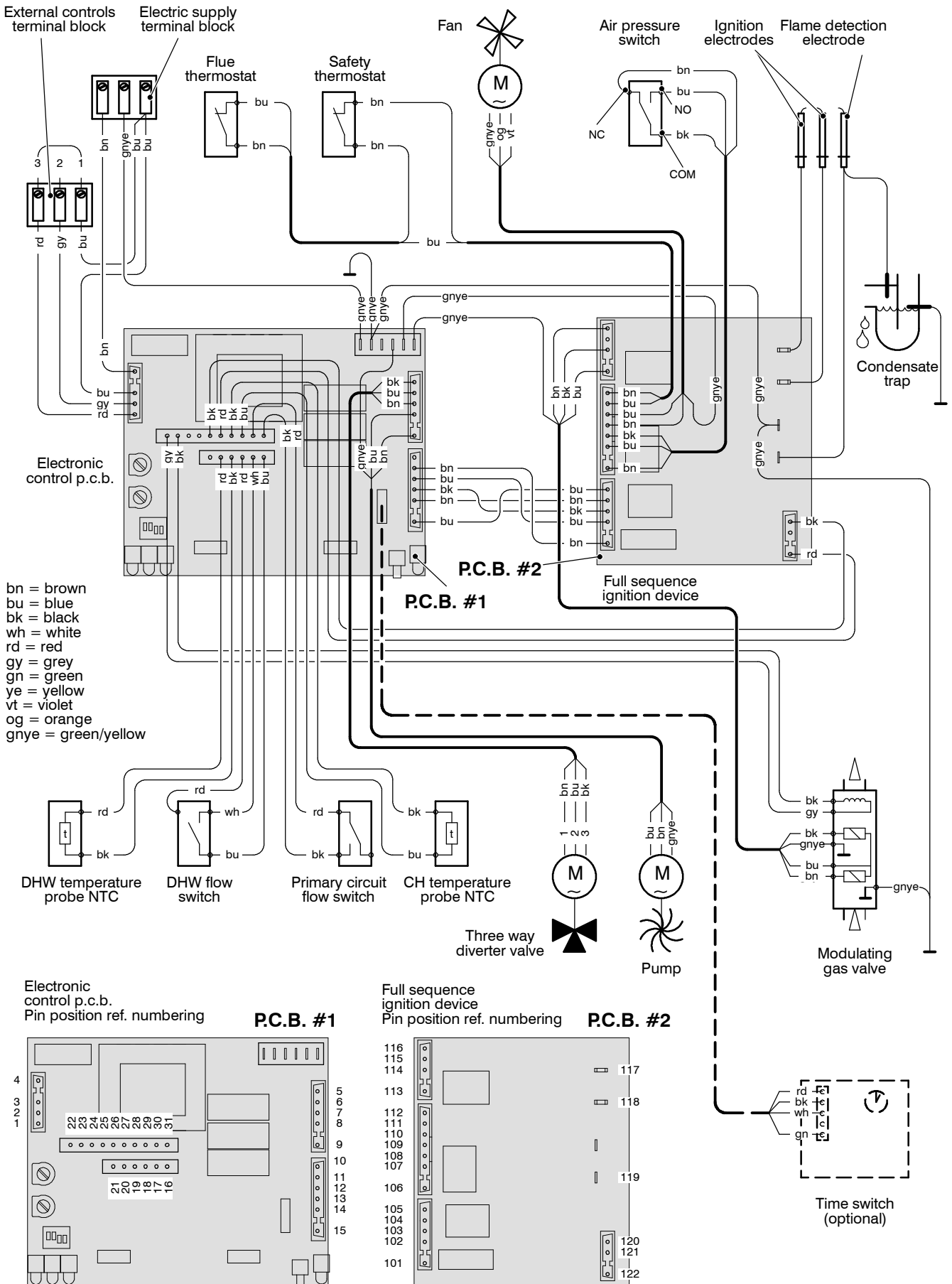

# INSTALLATION

**Wiring diagram for boiler equipped with full sequence ignition device type: Honeywell FPLD**

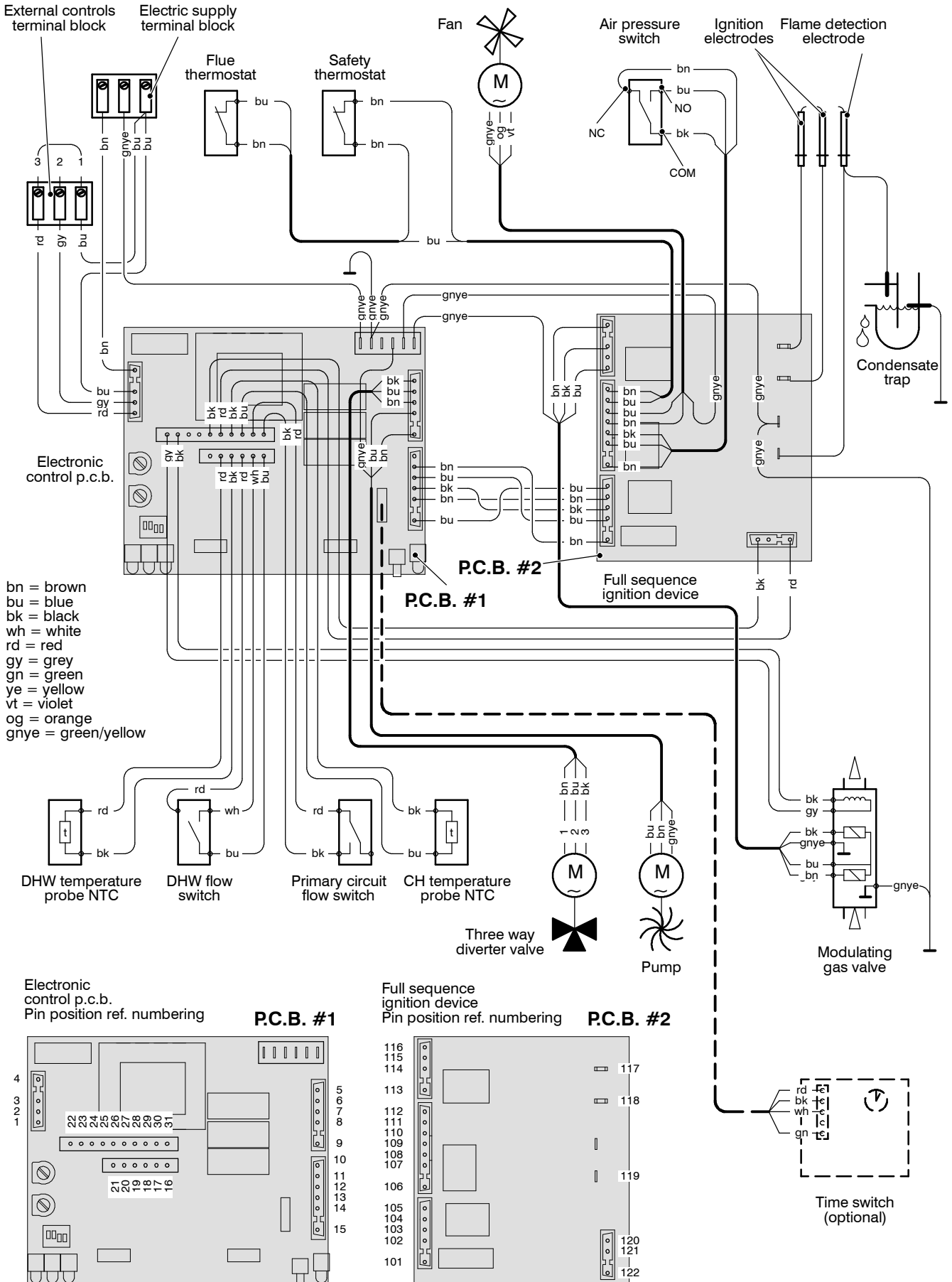

**INSTALLATION**

24 FUNCTIONAL FLOW DIAGRAM  
mini HE C24, mini HE C28,

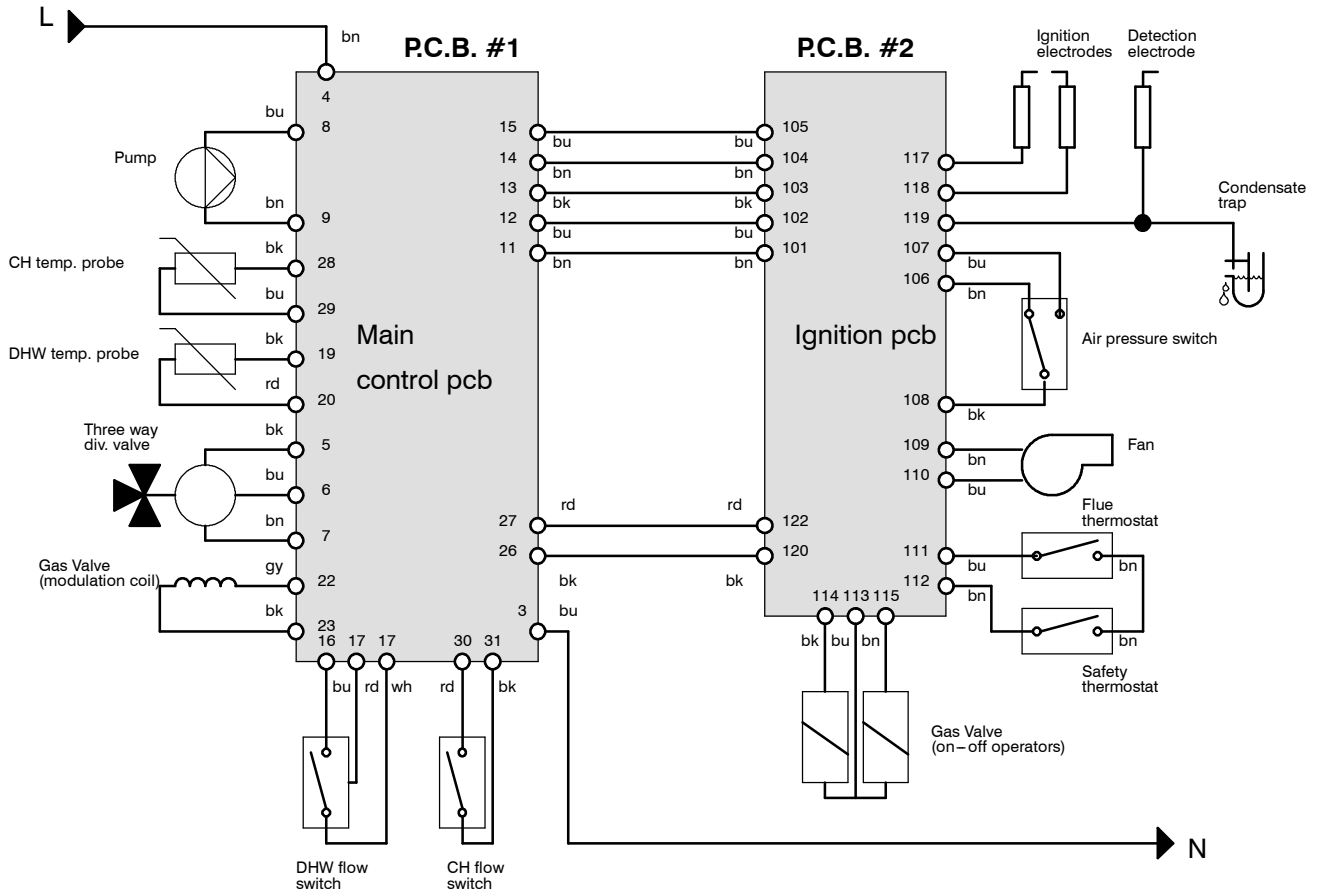

## 25 EXTERNAL ELECTRICAL CONTROLS

Wiring external to the boiler MUST be in accordance with the current I.E.E. (BS.7671) Wiring Regulations.

For Ireland reference should be made to the current ETCI rules for electrical installations.

The fuse rating should be 3A.

Route the electrical supply flexible cord and the external control flexible cord as illustrated.  
Lock the flexible cords in place with the clamps provided.

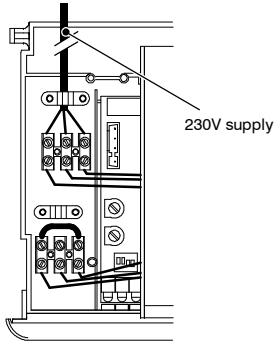

## ELECTRICAL CONNECTIONS FOR A COMBI BOILER

### Optional Programmer Kits

Optional digital programmer kits are available with their relevant instructions.

Both 24hr and 7day kits are available.

**Note: the switch contacts of any external programmer, room or frost thermostat must be volt free. Connecting a switched live feed to external controls terminal block may be dangerous and will result in serious damage to the boiler.**

### Room Thermostat

This should be wired as shown in diagrams A.

### Frost protection

Central heating systems fitted wholly inside the house do not normally require frost protection as the house acts as a 'storage heater' and can normally be left at least 24 hours without frost damage.

However, if parts of the pipework run outside the house or if the boiler will be left off for more than a day or so then a frost thermostat should be wired into the system.

To maintain frost protection with the programmer selector

switches set to OFF, all the controls MUST be left in the running position.

The frost thermostat should be sited in a cold place but where it can sense heat from the system.

Wiring should be as shown, with minimal disturbance to other wiring.

### External Programmers

On the combi boilers, this should be of the single channel type (as this boiler does not incorporate a pre-heat facility for the instantaneous hot water service).

Programmers with room thermostat – see diagram B.

*Note. If the boiler is installed in a garage it may be necessary to fit a pipe thermostat, preferably on the return pipework.*

*Earths are not shown for clarity but must never be omitted.*

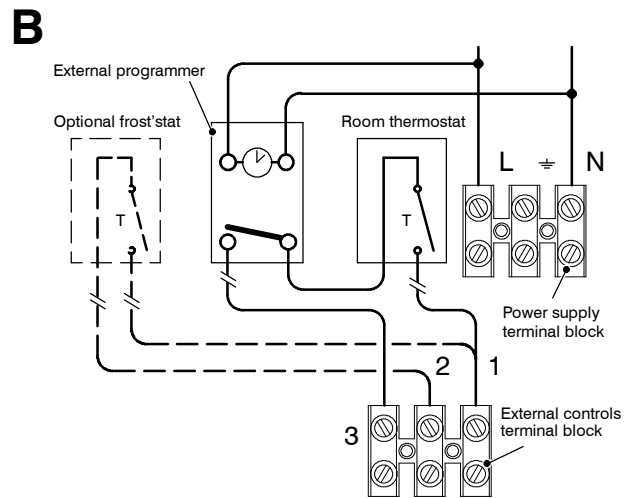
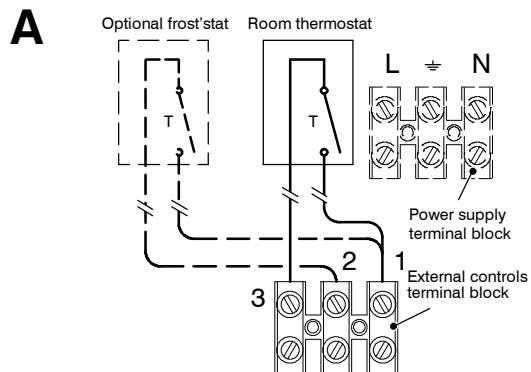

**N.B. These diagrams are schematic only and do not show external terminal strips etc.**

## 26 INITIAL LIGHTING

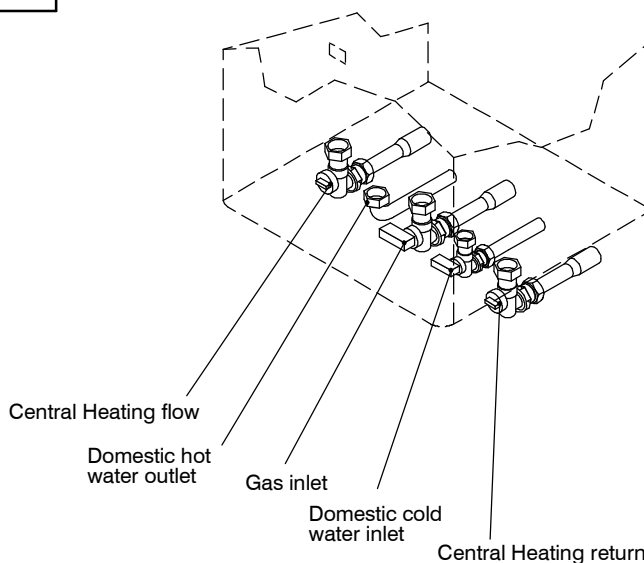
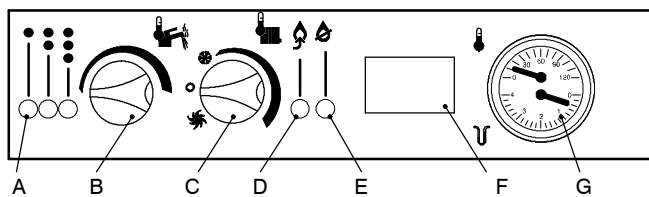

### Legend

- A Appliance On lamp
- B Domestic hot water temperature control
- C Main switch and radiator temperature control
- D Boiler reset button
- E Lock-out signal lamp
- F Programmer (optional)
- G System pressure and temperature gauge

### IMPORTANT Before lighting the boiler you should note especially that:

- 1 Check that all the drain cocks are closed and any valves in the flow and return are open.
- 2 Check that the system has been filled and pressurised and that the boiler is not air locked.
- 3 Remove boiler front panel.
- 4 Ensure the dust cap on the automatic air vent is open at least one full turn and leave this permanently open
- 5 Ensure that the pump is free to rotate
  - i Remove the vent plug
  - ii Using a screwdriver, rotate the shaft several times
  - iii Replace the vent plug

**Note.** Some slight water leakage will occur
- 6 Remove the screw in the burner pressure test point indicated on the following picture and connect a gas pressure gauge via a flexible tube.  
Be sure to select the correct pressure test point. Refer to Tables for pressures.

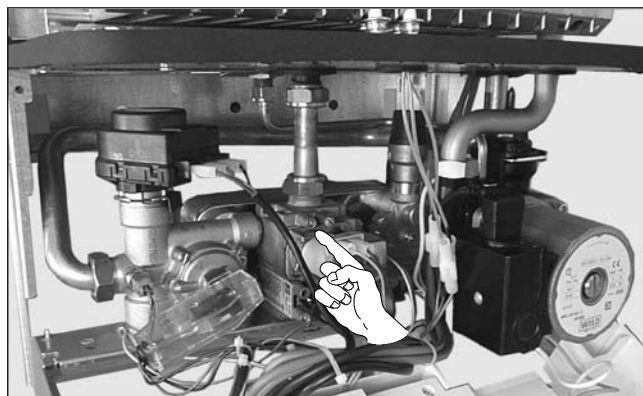

- 7 Check that the gas service cock is ON.
- 8 Switch the electricity supply ON and check that all external controls are calling for heat.
- 9 Set the main switch C to 'ON'. Following a pre-purge period the gas control solenoid valve should open and the spark commence, continuing until the burner is established.
- 10 Check that the burner lights smoothly. If this does not occur within 20 seconds, turn the main switch to 'O' position, wait for 5 seconds then try again by pressing the reset button 'D'. If the burner still does not light, refer to the 'Fault Finding' section.
- 11 Test for gas soundness around ALL boiler gas components, using leak detection fluid.
- 12 Operate the boiler for 10 minutes to stabilise the burner temperature.
- 13 Check that the burner pressures are correct. The boiler is factory pre-set and should not need adjustment. However if adjustment is required refer to frame 27.
- 14 Set the boiler main switch to 'O'.
- 15 Remove the pressure gauge and tube. Replace the sealing screw in the pressure test point. Ensure a gas tight seal is made.
- 16 Refit the boiler front panel using the screws previously removed.
- 17 Switch the boiler on again.

## INSTALLATION

### 27 TO ADJUST PRESSURES

Nomenclature of the parts on the gas valve

- A Modulation operator's electric connectors
- B Minimum gas pressure adjustment
- C Maximum gas pressure adjustment
- D Gas valve inlet pressure test point
- E Burner pressure test point

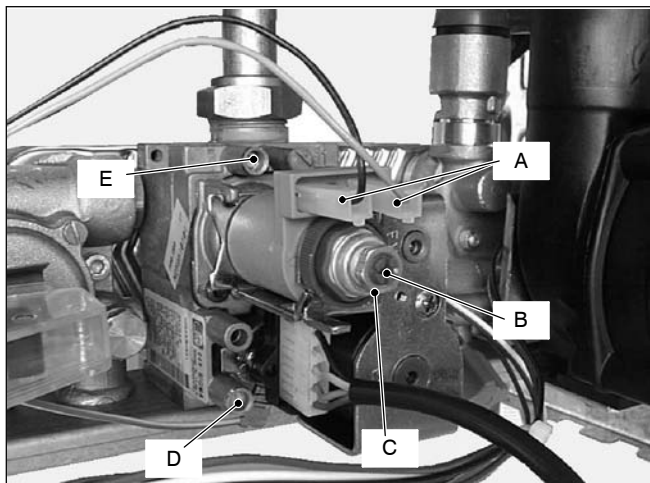

- 1 Remove the front panel of the case.
- 2 Open the gas valve inlet pressure test point D at the valve input, connect a suitable pressure gauge and check the gas pressure of the supply network.
- 3 Remove the gauge and close the pressure test point D.
- 4 Open the burner pressure test point E and connect the gauge.
- 5 Remove the protection cap from the mechanical pressure adjustment components (B and C)
- 6 Start the boiler at its maximum power.  
Operate the boiler in DHW mode or ensure that the boiler is not range rated if the test is carried out in CH mode.

#### Maximum valve setting

- 7 If necessary, rotate the **maximum** gas pressure adjustment C using a spanner until you obtain the required pressure as indicated on Table 1 at page 4 (burner pressure).  
By rotating clockwise the pressure increases.

#### Minimum valve setting

- 8 Disconnect one of the two connectors A.
- 9 If necessary, rotate the **minimum** gas pressure adjustment B using a pozidrive screwdriver until you obtain the required pressure as indicated on Table 1 at page 4

(burner pressure).

By rotating clockwise the pressure increases.

- 10 Turn the boiler off and re-connect the wire to the modulating operator.
- 11 Start the boiler and check again the maximum gas pressure setting.
- 12 Turn the boiler off and disconnect the gauge and close the gas valve outlet pressure test point E

**Important: after the gas pressure checks and any adjustment operations, all of the test points must be sealed.**

#### Ignition rate adjustment

- 1 Turn on the boiler.
- 2 Check that the boiler lights up uniformly and adjust the ignition gas pressure, if necessary.

To adjust the ignition gas pressure:

- 3 Open the gas valve outlet pressure test point E and connect the gauge.
- 4 Loosen the screws F and remove the service panel

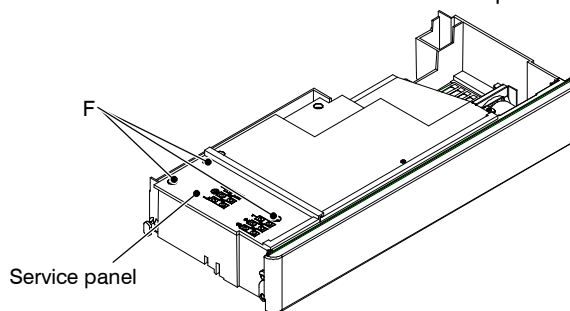

- 5 set dip-switch "3" to the OFF position and adjust potentiometer marked "ACC" with a screwdriver until correct ignition gas pressure is obtained.

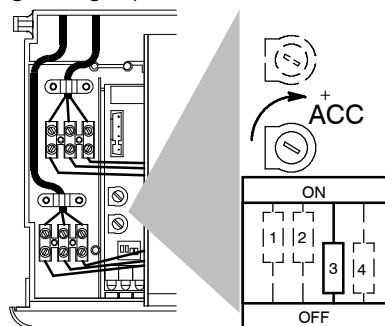

Suggested ignition pressures:

- Natural gas G20 – 6 (2,4) mbar (in w.g.)
- Propane G31 – 13 (5,3) mbar (in w.g.)

## 28 ANTI CYCLING SETTING

If the dipswitch number 4 on the main P.C.B. is set to the 'ON' position it will activate the re-ignition delay period of approximately 3 minutes. When dipswitch number 4 is set to the 'OFF' position there will be approximately 30 seconds re-ignition delay period.

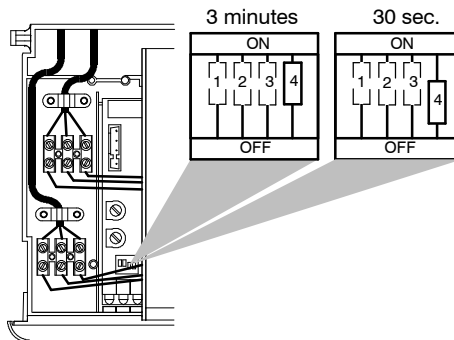

## 29 COMMISSIONING AND TESTING

The benchmark Logbook or equivalent self certification should be completed and signed to demonstrate compliance with Building Regulations.

### A. Electrical Installation

Checks to ensure electrical safety should be carried out by a competent person.

ALWAYS carry out the preliminary electrical system checks, i.e. earth continuity, polarity, resistance to earth and short circuit, using a suitable test meter.

### B. Gas Installation

- 1 The whole of the gas installation, including the meter, should be inspected and tested for soundness and purged in accordance with the recommendations of BS. 6891. In IE refer to I.S. 813:2002.
- 2 Purge air from the gas installation by loosening the gas cock union and purge until gas odour is detected.
- 3 Retighten the union and test for gas soundness.

**WARNING. Whilst effecting the required gas soundness test and purging air from the gas installation, open all windows and doors, extinguish naked lights and DO NOT SMOKE.**

## 30 GENERAL CHECKS

Make the following checks for correct operation:

### 1 Hot water.

- a. Fully open all DHW taps in turn and ensure that water flows freely from them.
- b. Close all taps except the furthest one from the boiler and check that the boiler is firing at maximum rate.
- c. Ensure that DHW temperature of approximately 35 °C rise is obtained at the tap. This corresponds to a flow rate of about

litres/min (gpm)	models
10.1 (2.2)	<b>mini HE C24</b>
11.7 (2.6)	<b>mini HE C28</b>

### d. Turn off the DHW tap.

### 2 Central heating (all models)

Operate each control separately and check that the main burner or circulating pump, as the case may be, responds.

### 3 Gas rate – G20

Check the boiler gas rate when the boiler is at full output.

The gas rate checked at the gas meter, with no other appliance in use will normally be:

litres/min (ft <sup>3</sup> /min)	models
44.2 (1.56)	<b>mini HE C24</b>
51.2 (1.81)	<b>mini HE C28</b>

If this check is not possible, ensure that the burner pressure is:

10.8 (4.3) mbar (in. w.g.) for the model **mini HE C24** and  
10.0 (4.0) mbar (in. w.g.) for the model **mini HE C28**.

mbar (in. w.g.)	models
10.8 (4.3)	<b>mini HE C24</b>
10.0 (4.0)	<b>mini HE C28</b>

### 4 Water circulation system

Note. Fernox Superfloc flushing solution should be used during the flushing procedure.

**a.** With the system HOT examine all water connections for soundness.

**b.** With the system still HOT, turn off the gas, water and electricity supplies to the boiler and drain down, to complete the flushing process.

**c.** Refill the system, adding inhibitor (see 'Water Treatment'), if required.

Vent as necessary to clear all air and, again, check for water soundness. After venting, repressurise as required.

**d.** Balance the system. It is suggested that, initially, all radiator handwheel valves (or TRVs if fitted) be set fully open, that all lockshield valves be set a half-turn open.

Make minor adjustments to each radiator to achieve the same differential on all.

### 5 Flue system

Check the integrity of the flue outlet and air inlet system to the boiler ensuring no leaks are evident from piping joints or flue/air sampling points.

Finally, set the system controls to the users requirements.

If an optional programmer kit is fitted refer to the instructions supplied.

## 31 GAS CONVERSION

- 1 Disconnect the electrical supply.
- 2 Replace the burner injectors as explained in frame 43.
- 3 Re-assemble the burner, the front panel of the combustion chamber and the lid of the sealed chamber.
- 4 Remove the service panel (frame 27 step 4).
- 5 Set correctly the dip-switch "2" to the correct position in accordance with the following table and drawing.

Gas supply	Position of dip-switch 2
Natural gas	On
Propane	Off

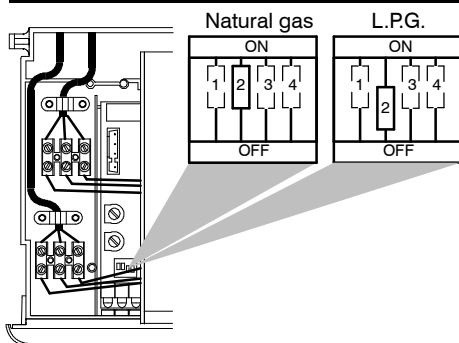

- 6 Adjust the burner pressures according to the indications given in frame 27.
- 7 Stick the self-adhesive label (included with the conversion kit, indicating the type of gas, and the gas pressures to which the appliance has been set) over the existing label on the bottom of the control panel.
- 8 Replace the service panel and the front and side panels of the case.
- 9 Check the correct operation of the boiler.

## 32 HANDING OVER

After completing the installation and commissioning of the system, the installer should hand over to the householder by the following actions:

- 1 Hand the User's Instructions to the householder and explain his or her responsibilities under the Gas Safety (Installation and Use) Regulations 1994 and amendments 1996 or rules in force.
- 2 Draw attention to the Lighting Instruction label affixed to the inside of the lower front door.
- 3 Explain and demonstrate the lighting and shutting down procedures.
- 4 The operation of the boiler and the use and adjustment of ALL system controls should be fully explained to the householder, to ensure the greatest possible fuel economy consistent with household requirements of both heating and hot water consumption.
- 5 Advise the user of the precautions necessary to prevent damage to the system and to the building, in the event of the system remaining inoperative during frosty conditions.

- 6 If a programmer is fitted, draw attention to the Programmer Instructions and hand them to the householder.
- 7 After installation and commissioning please complete the **benchmark** Commissioning Checklist before handover to the customer.  
For IE, it is necessary to complete a "Declaration of Conformity" to indicate compliance to I.S. 813:2002.
- 8 Stress the importance of regular servicing by a CORGI registered installer and that a comprehensive service should be carried out **AT LEAST ONCE A YEAR**. In IE, servicing work must be carried out by a competent person.

Emphasise to the user that the boiler may stop working if the system pressure is lowered by draining radiators to decorate behind them. In particular, explain to the user how the domestic hot water temperature varies with flow rate. This is especially important when water is drawn off while the boiler is already running for central heating.

## 33 SERVICING SCHEDULE

To ensure the continued safe and efficient operation of the appliance it is recommended that it is checked at regular intervals and serviced as necessary.

The frequency of servicing will depend upon the installation condition and usage but should be carried out at least annually.

It is the law that any service work must be carried out by a registered CORGI installer.

In IE, servicing work must be carried out by a competent person.

- 1 Turn the heating controls to maximum so that the boiler lights and remains running. Check that no other gas appliances in the house are in use or likely to be used.
- 2 When the boiler has settled down check the gas rate at the meter (if the meter is of the pointer type you should time only complete revolutions of the pointer). Check the gas rate against the figures given in Table 2 for CH operation.
- 3 For a combination boiler, fully open a hot water tap. When the boiler has settled down check the gas rate, as in step 2, checking the measured rate against the figures given in Table 3 for HW operation.
- 4 Run the boiler and check the percentage of CO and CO<sub>2</sub> in the flue gases at the sampling point indicated in the following drawing.

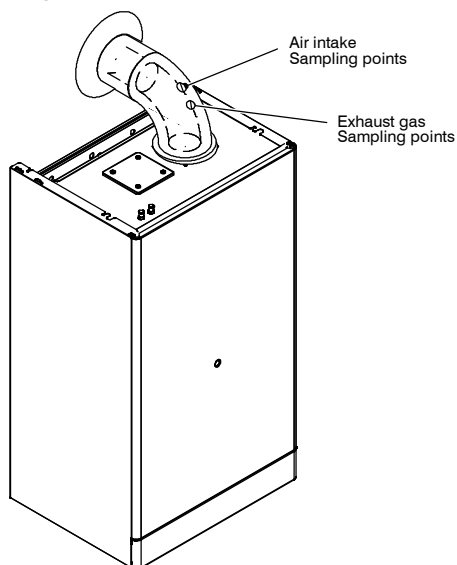

*Note. If your meter reads CO in parts per million the figure must be divided by 10,000 to convert it to a percentage.*

- 5 If the ratio of CO/CO<sub>2</sub> is less than ,004 and the gas rates measured in steps 3 and 4 are close to nominal then no further action need be taken. If not, proceed to step 6.
- 6 Clean the main burner.
- 7 Clean the heat exchanger.
- 8 Check the injectors for blockage or damage.
- 9 Check that the flue terminal is unobstructed.

The servicing procedures are covered more fully in Frames 34 to 36 and **MUST** be carried out in sequence.

### WARNING.

ALWAYS turn off the gas supply at the gas service cock, and switch off and disconnect the electricity supply to the appliance before servicing.

**Switching the boiler on/off switch 'off' does not fully isolate the boiler.**

ALWAYS test for gas soundness and carry out functional checks on reassembly.

**IMPORTANT.** When work is complete the boiler inner front sealing panel **MUST** be correctly refitted, making a good seal.

**DO NOT OPERATE THE BOILER IF THE SEALING PANEL IS NOT FITTED.**

**Complete the service section in the Benchmark Commissioning Checklist.**

## 34 REMOVAL OF OUTER AND INNER CASING

- 1 Turn off the gas supply at the gas service cock and disconnect the electricity supply.
- 2 Remove the screws A and lift off the boiler front panel.

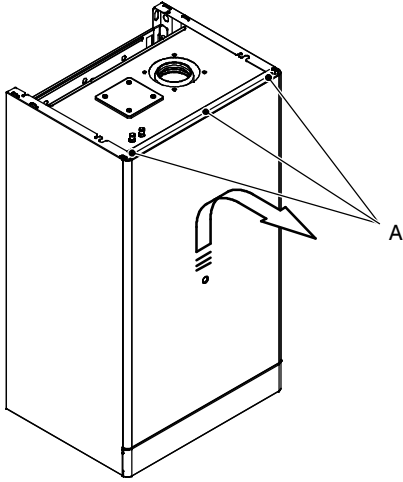

- 3 Loosen the screws B.
- 4 Bring the base of the panels away from the boiler and lift them, freeing them from the top hooks.

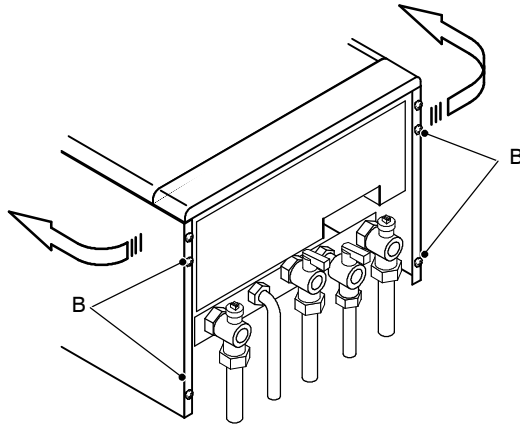

- 5 Remove the screws C and remove the boiler inner casing.

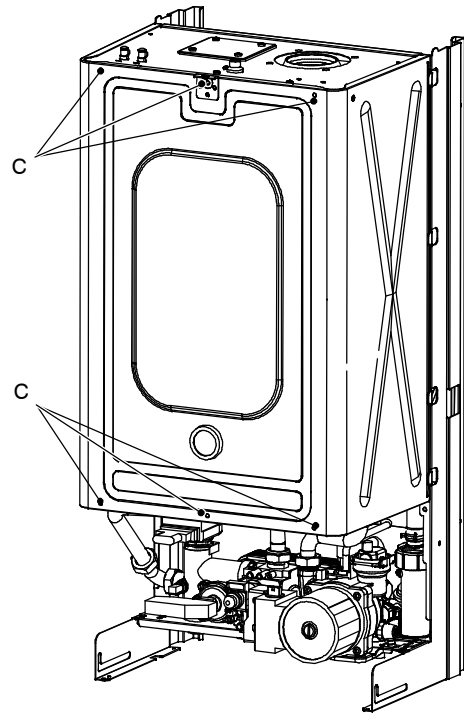

## SERVICING

### 35 BURNER REMOVAL AND CLEANING

- 1 Disconnect the electrical supply.
- 2 Remove outer and inner casing (refer to frame 34).
- 3 Undo the screws A and remove the fan holder bracket B and the combustion chamber panel C.
- 4 Remove the screws D and the plate E.

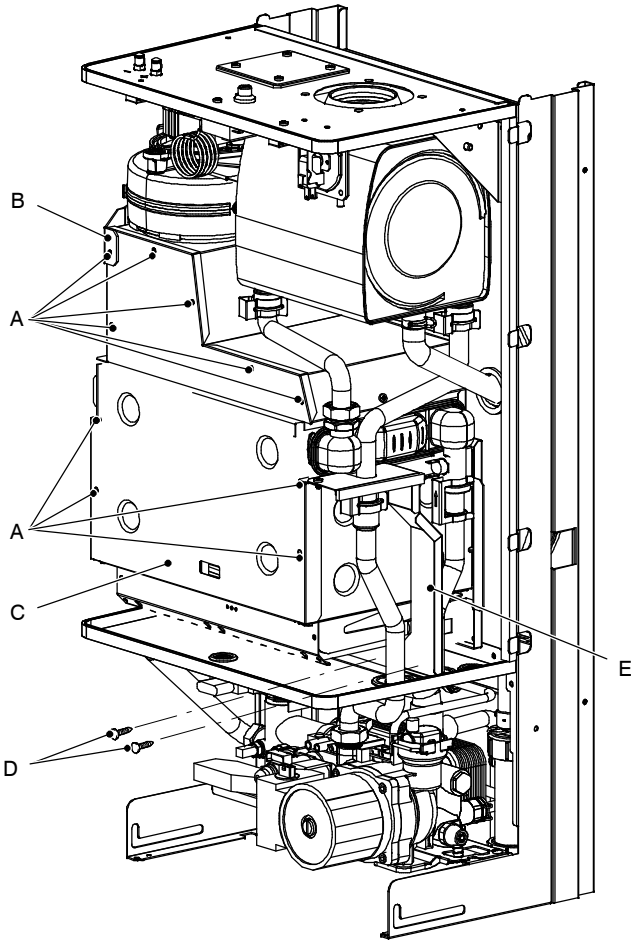

- 5 Disconnect the electrodes leads.

### 36 BURNER PRESSURE CHECK

After any servicing, reference should be made to:

– Table 2 and Table 3 (or the data plate) which quote details of the burner pressures.

### 37 CLEANING THE HEAT EXCHANGER

- 1 Open the combustion chamber as explained in steps 1 to 3 of frame 35.

### 38 RE-ASSEMBLY

Re-assemble the boiler in the following order:

- 3 Refit the burner.
- 4 Reconnect the electrodes to the ignition pcb. See frame 35 for correct connectors.
- 5 Refit the combustion chamber panel and the fan holder bracket.

- 6 Undo the four screws F placed at the right and left sides of the burner and extract it.

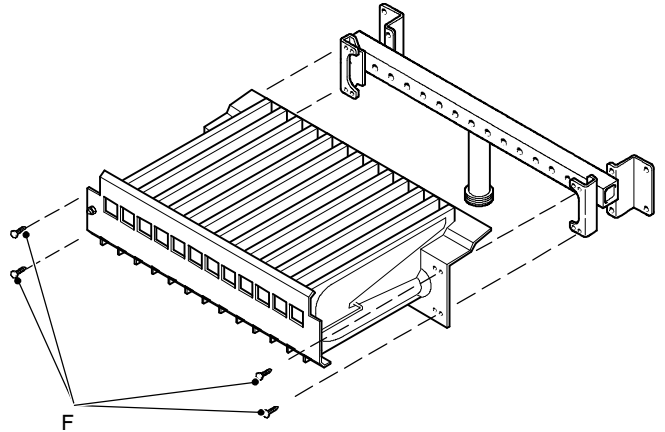

- 7 Brush off any deposits that may have collected on the burner, ensuring that the flame ports are unobstructed. Note: brushes with metallic bristles **MUST NOT** be used.
- 8 Inspect the spark and detection electrodes. Ensure they are clean and in good condition; replace if necessary.
- 9 Check the spark electrodes gap is correct.

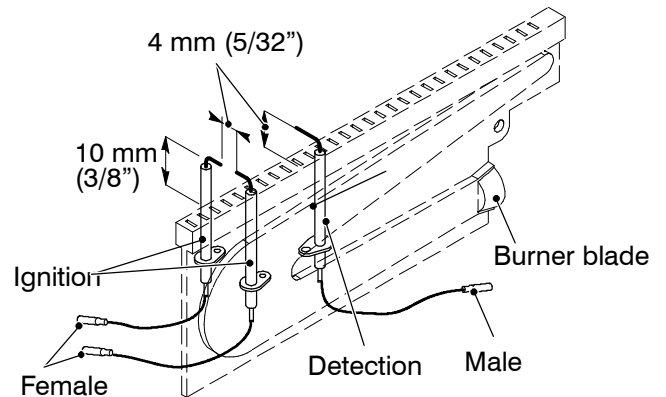

- 10 Check that the spark and detection electrodes leads are in good condition and renew as necessary.

If the burner pressures are incorrect ensure the inlet pressure, with the appliance running, is correct (refer Table 1).

If the burner pressures require adjustment refer to frame 27 "To adjust pressures".

If the appliance still does not operate correctly refer to the appropriate fault finding chart.

- 2 Place a plastic sheet or similar beneath the heat exchanger and remove all visible loose deposits from the heat exchanger fins, using a suitable brush.

- 6 Refit the inner case cover. **IMPORTANT.** Ensure the boiler sealing panel is correctly fitted and that a good seal is made.

- 7 Refit the boiler side and front panels.
- 8 Turn on the gas supply at the gas service cock.
- 9 Reconnect the electrical supply.

## 39 FAN AND VENTURI REMOVAL AND CLEANING

- 1 Disconnect the electrical supply.
- 2 Remove outer and inner casing.
- 3 Disconnect the connectors A and the earth connection B.
- 4 Disconnect the pipe which connects the venturi device to the air pressure switch.
- 5 Unscrew the screw C and remove the fan holder bracket D.

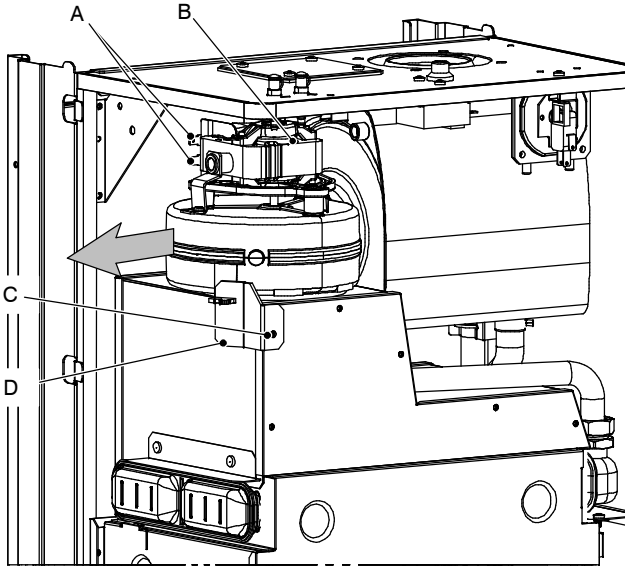

- 6 Remove the fan by sliding it towards left (see the arrow).

- 7 Check that the impeller runs freely. Clean with a soft brush or renew as necessary. Refer to frame 51 for replacement.

**Note: Always take care when handling the fan, in order to preserve the balance of the impeller.**

- 8 Check the venturi E for cleanliness.

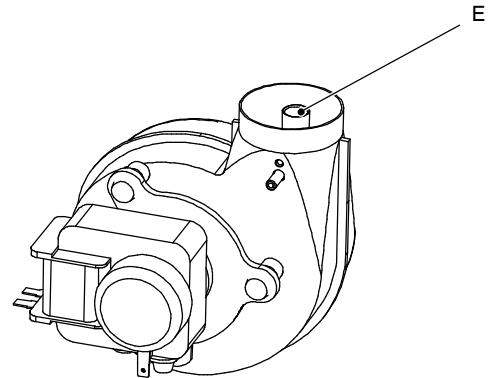

- 9 Re-assemble in reverse order.

**To correctly connect the venturi device to the air pressure switch, refer to the following illustration.**

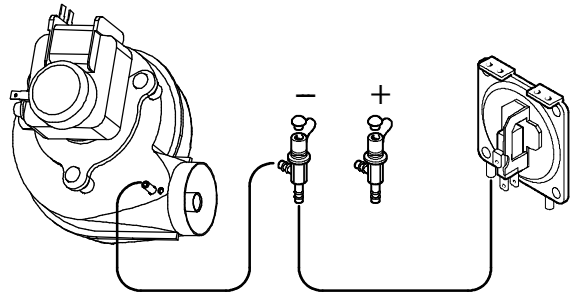

# REPLACEMENT OF COMPONENTS

## 40 GENERAL

When replacing any component:

- 1 Isolate the electricity supply at the switched spur.  
**N.B.** Turning the boiler "ON/OFF" switch does not isolate the live supply to the boiler.
- 2 Turn off the gas supply.

IMPORTANT. When work is complete the inner case cover must be correctly fitted, ensuring that a good seal is made.

**THE BOILER MUST NOT BE OPERATED IF THE INNER CASE COVER IS NOT FITTED.**

If the CH and/or the DHW circuits have been emptied:

- 3 Open the hydraulic circuit cocks, refill / re-pressurise pipeworks and vent the system.
- 4 Test fire the boiler
- 5 Disconnect the filling loop.
- 7 Check the spark gap.

## 41 SPARK AND DETECTION ELECTRODE REPLACEMENT

- 1 Disconnect the electrical supply.
- 2 Remove outer and inner casing (refer to frame 34).
- 3 Open the combustion chamber and disconnect the electrodes leads.
- 4 Remove the burner. Refer to frame 35.
- 5 Undo the screws that hold the electrodes and remove.
- 6 Fit new electrodes as necessary following the sequence illustrated.

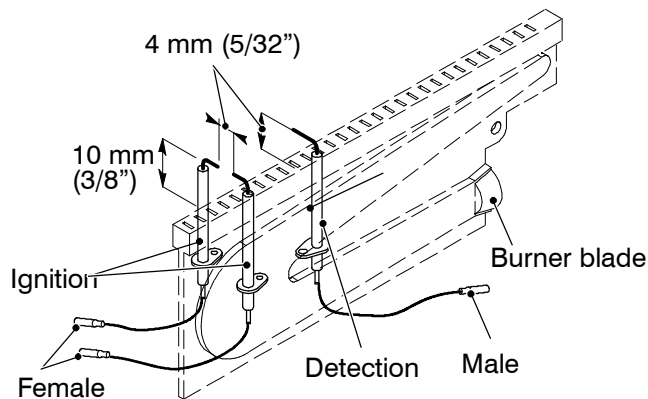
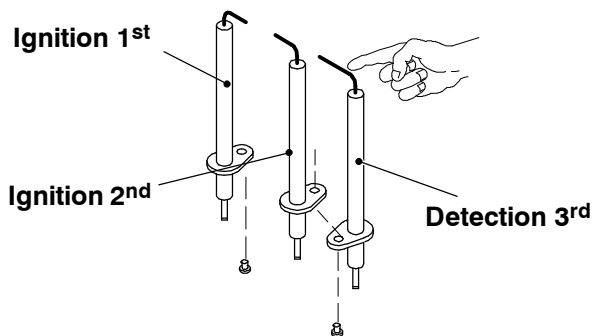

- 8 Re-assemble in reverse order.
- 9 Check the ignition and operation of the burner.

## 42 BURNER REPLACEMENT

- 1 Remove the burner as explained in frame 35
- 2 Remove the spark and detection electrodes. Refer to frame 41.

- 3 Fit the electrodes on the new burner and check the spark gap.
- 4 Re-assemble in reverse order.
- 5 Check the operation of the boiler.

## 43 BURNER INJECTORS REPLACEMENT

- 1 Remove the burner. Refer to frame 35.
- 2 Unscrew the injectors from the gas manifold.
- 3 Check that the new injectors are of the correct size and fit it using new gaskets.
- 4 Re-assemble in reverse order.
- 5 Check the operation of the boiler.

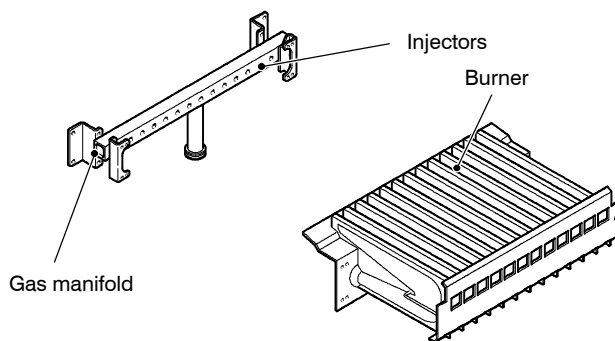

## 44 OVERHEAT THERMOSTAT REPLACEMENT

- 1 Remove outer and inner casing (refer to frame 34).
- 2 Remove the screws A and the plate B.

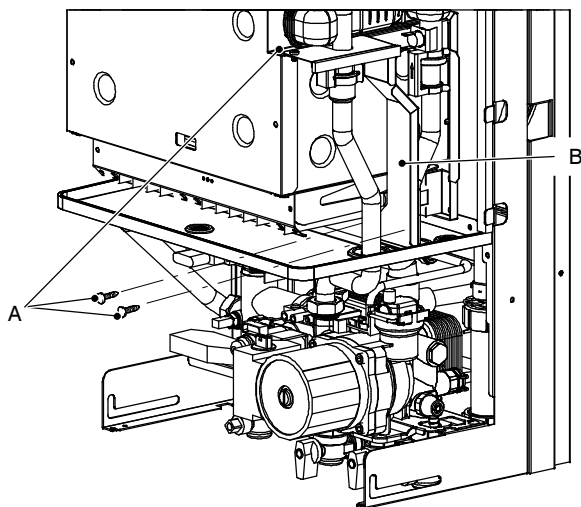

- 3 Disconnect the wiring C .
- 4 Remove the spring D which holds the overheat thermostat on the pipe of the primary heat exchanger and remove it.

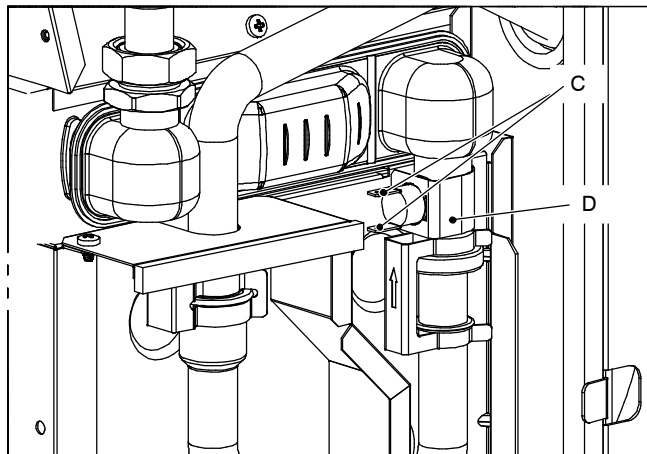

- 5 Re-assemble in reverse order.
- 6 Apply an adequate quantity of heat conducting compound between the pipe and the thermostat.

## 45 FLUE THERMOSTAT REPLACEMENT

- 1 Remove outer and inner casing (refer to frame 34).
- 2 Disconnect the wires from the flue thermostat.
- 3 Unscrew and remove the thermostat probe A from the recuperator.
- 4 Remove the protective cap B and unscrew the screws C which hold the flue thermostat to the frame.
- 5 Remove the flue thermostat.
- 6 Assemble the flue thermostat carrying out the removal operations in reverse sequence.

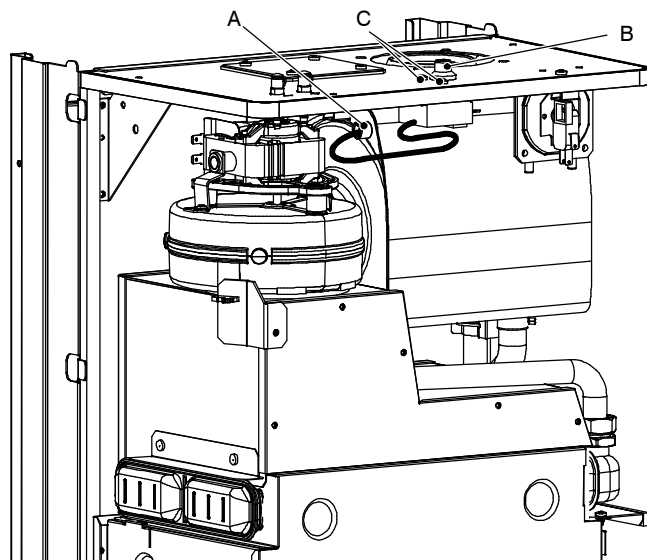

## 46 THERMISTOR REPLACEMENT

- 1 Disconnect the electrical supply.
- 2 Remove the front and right hand side casing panels (refer to frame 34).

### Removal of CH thermistor

- 3 To remove the CH thermistor close off the isolating cocks of the CH circuit at the bottom of the boiler.
- 4 Release system pressure by opening the main circuit drainage cock.  
**Do not release CH pressure using the pressure relief valve. It may cause debris within the system to foul the valve.**

### Removal of DHW thermistor

- 3 To remove the DHW thermistor close off the isolating cock of the DHW circuit at the bottom of the boiler.
- 4 Empty the DHW circuit.
- 5 Disconnect the leads from the thermistors to be replaced and unscrew it .

- 6 Screw in the new sensor, using a new gasket, reconnect and re-assemble in reverse order.

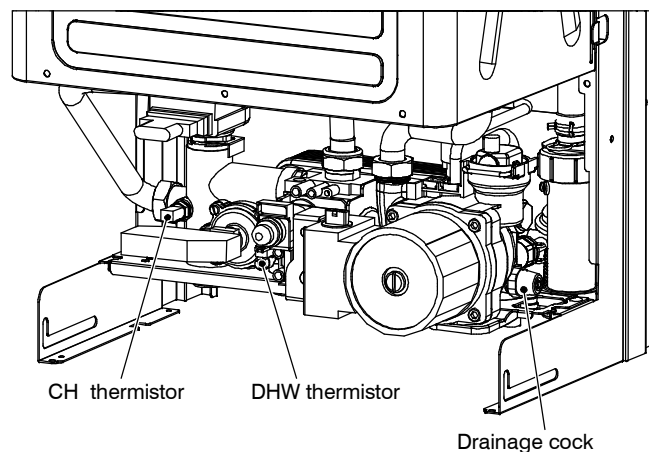

## SERVICING

## 47 GAS VALVE ON-OFF OPERATOR COILS REPLACEMENT

### Check

- 1 Disconnect the electrical supply.
- 2 Remove the front casing panel.
- 3 Disconnect the connector A and check the electrical resistance of the coils referring to the following diagram

Upper on-off operator  
approx. 6 400  $\Omega$ \*

Lower on-off operator  
approx. 920  $\Omega$ \*

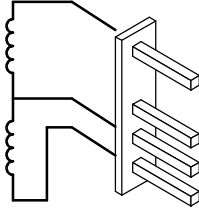

\* at ambient temperature.

- 4 If the resistance of either of the coils is different from the value stated by  $\pm 10\%$  or greater, replace the unit as described below.

### Replacement

- 5 Remove the screw B, withdraw the coils unit C.
- 6 Replace it and re-assemble in reverse order.

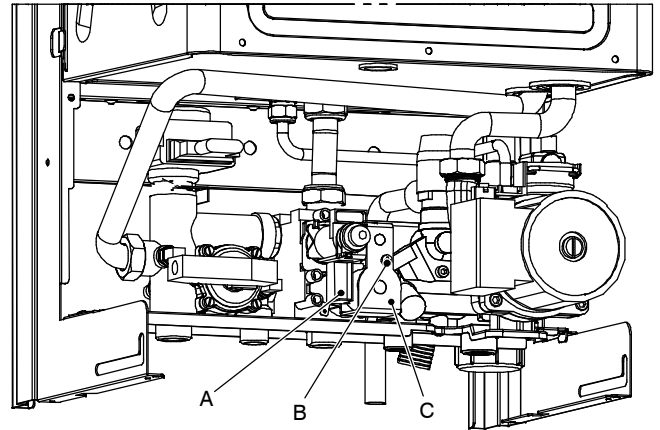

## 48 GAS VALVE REPLACEMENT

- 1 Turn off the gas supply at the gas service cock and disconnect the electricity supply.
- 2 Remove the front casing panel (refer to frame 34).
- 3 Disconnect the connectors A and B.
- 4 Disconnect the earth wiring from the gas valve.
- 5 Unscrew the connectors C and remove the pipe D
- 6 Unscrew the inlet connector.
- 7 Unscrew the screws E and remove the valve.
- 8 Fit the new gas valve in reverse order ensuring new gaskets are fitted and check for gas soundness.
- 9 Check the operation of the boiler.

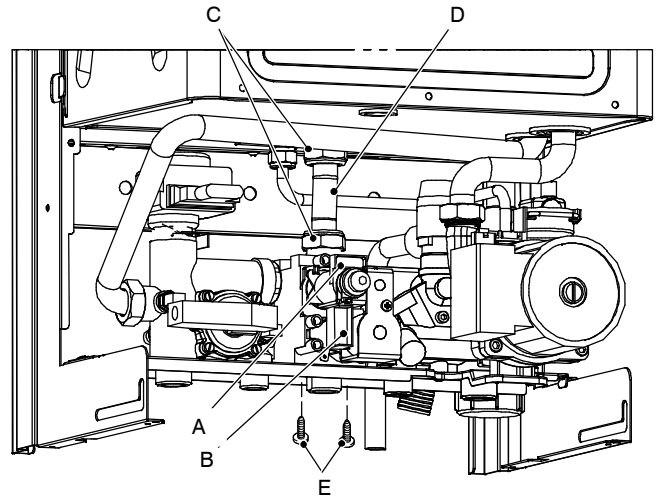

## 49 WATER TEMPERATURE-PRESSURE GAUGE REPLACEMENT

- 1 Disconnect the electrical supply.
- 2 Remove the front and right hand side casing panels (refer to frame 34).
- 3 Release system pressure by opening the main circuit drainage cock A  
**Do not release CH pressure using the pressure relief valve. It may cause debris within the system to foul the valve.**
- 4 Remove the fork B and the probe holder spring C.
- 5 Pull out the control panel (see frame 22).
- 6 Squeeze the tabs D to release the temperature-pressure gauge E and remove it.
- 7 Re-assemble in reverse order.

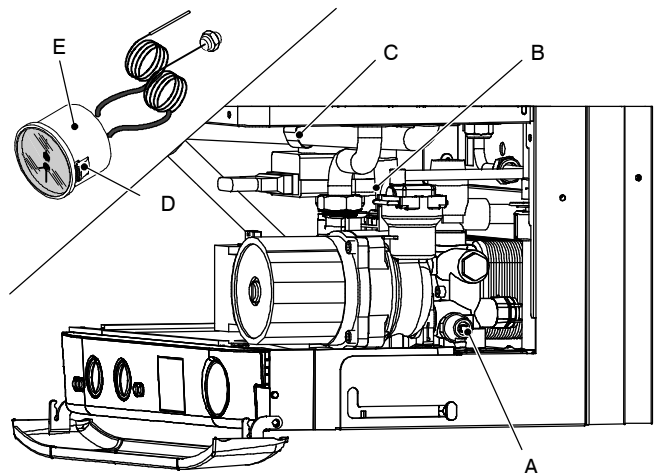

### 50 EXPANSION VESSEL REPLACEMENT

If the CH expansion vessel is faulty, there are 2 options:

- A If it has a punctured diaphragm, but is otherwise leak free, than it can be left in place and a new vessel added to the return side of the system, external to the boiler, provided it is of adequate capacity and pre-charge pressure.
- B If there is at least 400 mm (16") clearance above the boiler, the expansion vessel can be changed without removing the boiler (rear exit flues will have to be disturbed).

For option B, proceed as follows:

- 1 Disconnect the electrical supply.
- 2 Gain access to the controls area by removing the boiler front panel (refer to frame 34).
- 3 Close off the isolating cocks of the CH circuit at the bottom of the boiler.
- 4 Release system pressure by opening the main circuit drainage cock.  
**Do not release CH pressure using the pressure relief**

valve. It may cause debris within the system to foul the valve.

- 5 Completely unscrew the connection A, the locknut B and remove the expansion vessel from the top of the boiler.

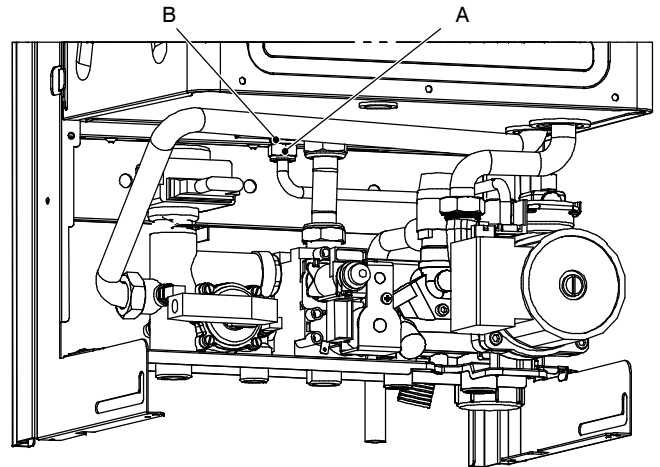

- 6 Re-assemble in reverse order.

### 51 FAN REPLACEMENT

- 1 Disconnect the electrical supply.
- 2 Remove outer and inner casing.
- 3 Disconnect the connectors A and the earth connection B.
- 4 Disconnect the pipe which connects the venturi device to the air pressure switch.
- 5 Unscrew the screw C and remove the fan holder bracket D.

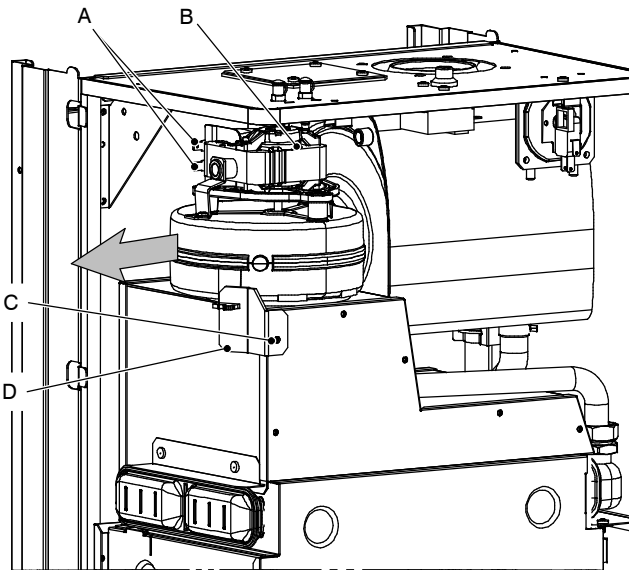

- 6 Remove the fan by sliding it towards left (see the arrow).
- 7 Re-assemble in reverse order.

**Note: Always take care when handling the fan, in order to preserve the balance of the impeller.**

**To correctly connect the venturi device to the air pressure switch, refer to the following illustration.**

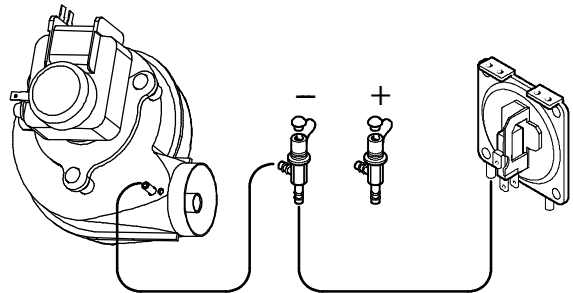

### 52 VENTURI REPLACEMENT

- 1 Remove the fan (see frame 51).
- 2 Remove and replace the venturi device A by unscrewing the screw B.
- 3 Re-assemble in reverse order.

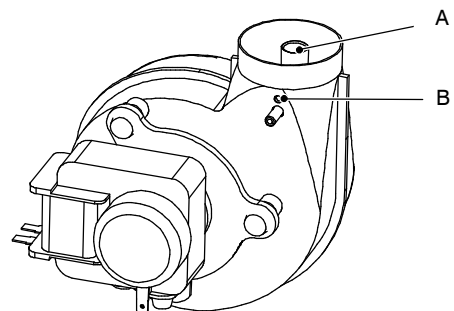

### 53 AIR PRESSURE SWITCH REPLACEMENT

Two different types of air pressure switch may be used in the boiler. Refer to the following drawings in accordance with the type of air pressure switch used.

- 1 Disconnect the electrical supply.
- 2 Remove outer and inner casing as explained in frame 34.
- 3 Disconnect the pressure sensing pipe from the air pressure switch.
- 4 Disconnect the electrical harness from the air pressure switch.
- 5 Undo the two screws which hold the air pressure switch to the chassis and remove it.
- 6 Replace the switch.
- 7 Re-assemble in reverse order.

**To correctly connect the venturi device to the air pressure switch, refer to the illustration of frame 51 and to the following illustrations in accordance with the type of pressure switch used.**

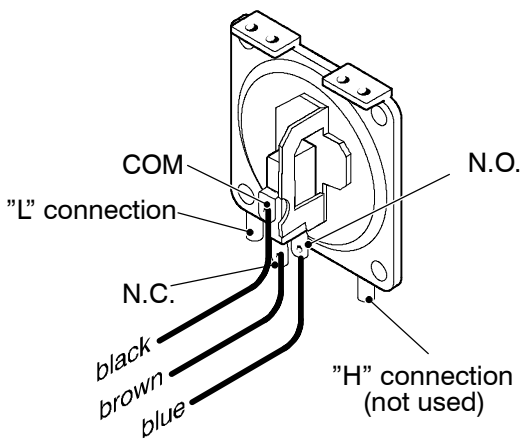
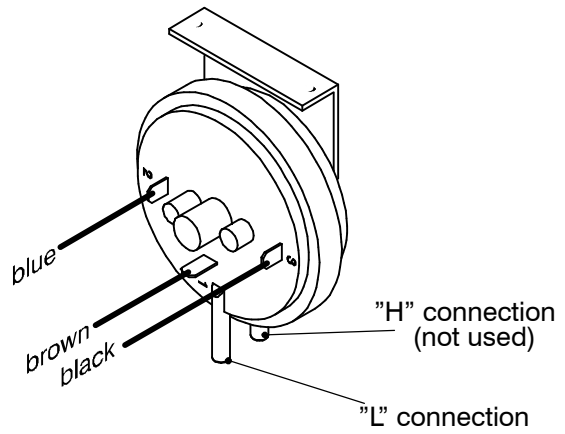

### 54 PUMP REPLACEMENT COMPLETE

- 1 Disconnect the electrical supply.
- 2 Remove the front and right hand side casing panels (refer to frame 34).
- 3 Release system pressure by opening the main circuit drainage cock.  
**Do not release CH pressure using the pressure relief valve. It may cause debris within the system to foul the valve.**
- 4 Disconnect the connector A.
- 5 Loosen the connector B.
- 6 Remove the fork C and the pipe D.

- 7 Remove the fork E and the connection of the capillary pipe of the pressure gauge.
- 8 Remove the locking plate F.
- 9 Completely loosen the connection G.
- 10 Unscrew the two screws H that hold the pump on the frame
- 11 Remove the pump towards the front of the boiler

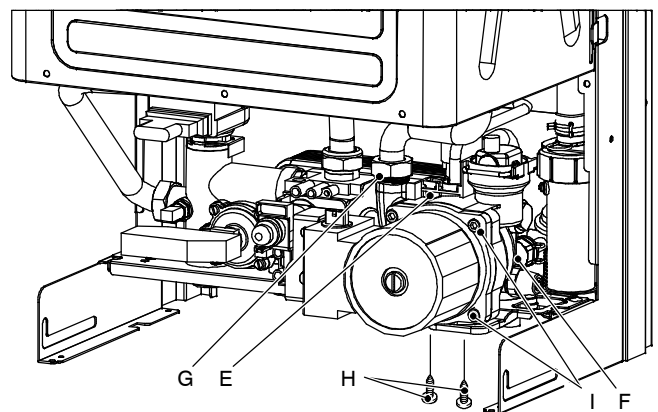
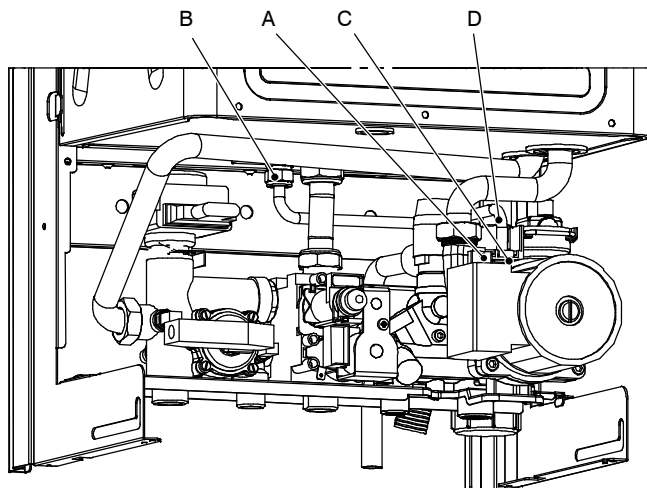

Re-assemble in reverse order.

When reassembling the pump, check the correct location of the O-ring gasket in the inlet port of the pump that seals the connection between the pump and the brass group .

If the motor only needs replacing, disconnect the connector A, unscrew the 4 screws I and remove the pump motor forwards.

### 55 MAIN CONTROL PCB REPLACEMENT

- 1 Disconnect the electrical supply.
- 2 Gain access to the controls area by removing the boiler front panel and pulling the control panel (refer to frame 22).
- 3 Remove the screws A and remove the service panel
- 4 To gain access to the main control p.c.b. and the ignition p.c.b. remove the screws B and remove the control panel lid.

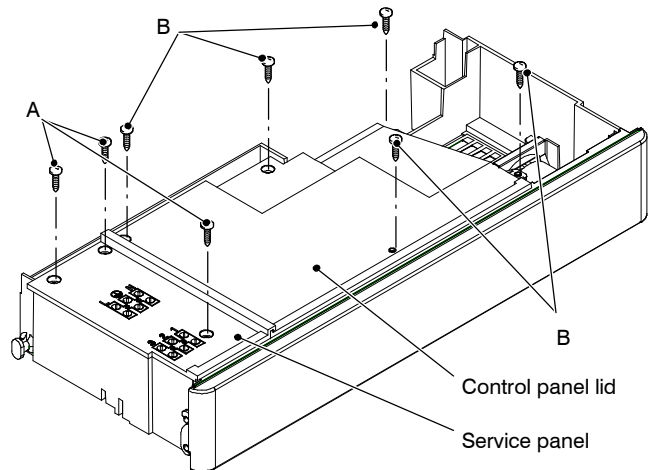

- 5 Remove all the wiring connected to the main control p.c.b. To disconnect the connectors indicated, delicately flex the hook present on one side of each socket.

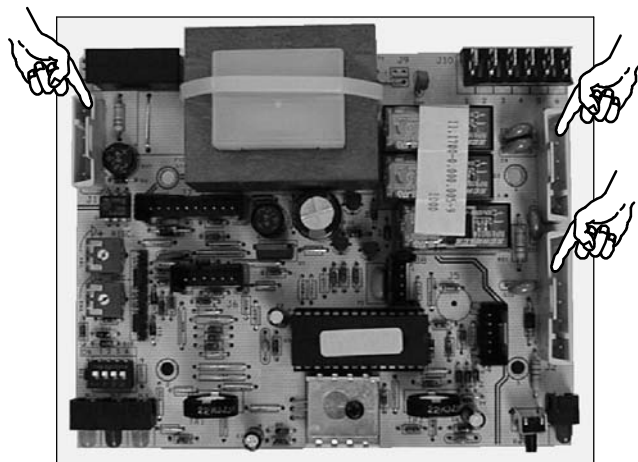

- 6 Remove the spindles of the CH and DHW temperature adjustment knobs by delicately pulling them with pliers in the direction shown by the arrow.

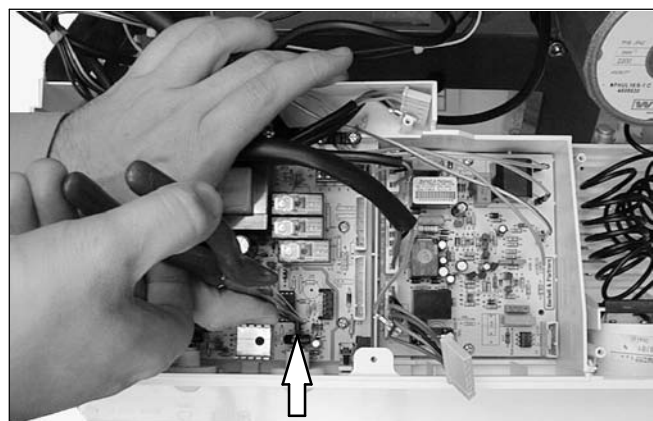

- 7 Unscrew the four screws that hold the main control p.c.b. on to the control panel.
- 8 Remove it by lifting its rear edge and freeing it from any of the wiring.
- 9 Re-assemble in reverse order.

#### Setting jumpers

Two setting jumpers C are fitted on the main control p.c.b.

Refer to the following illustration for the position of the jumpers when the main control p.c.b. is fitted.

The numbers refer to the marking printed on the circuit board.

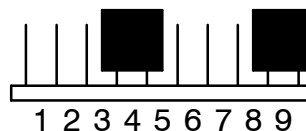

#### Important

When re-assembling the electronic control p.c.b.:

- 10 Fit the p.c.b. into the control panel by first inserting the front lower edge under the control knob shafts. Lower the rear edge and ensure that no wiring is trapped beneath.
- 11 Insert the spindles in the control panel knobs until the notch D reaches the potentiometer edge. It is not necessary to force them in the knob.
- 12 While tightening the screws that fix the main control p.c.b. on the control panel, keep the p.c.b. towards the control panel fascia making sure of the contact between the boiler reset button E and the tab F. Replace the wiring connections ensuring correct engagement in the sockets

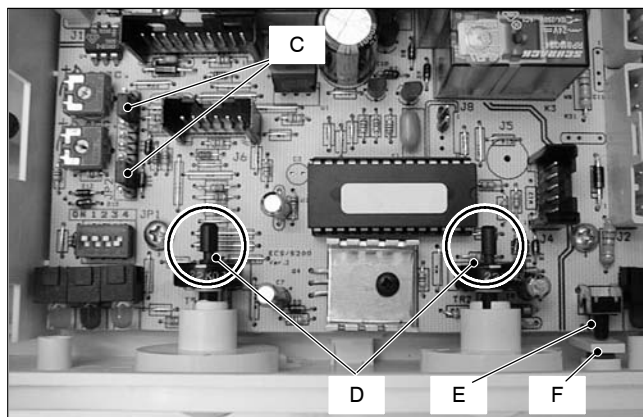

#### Attention

After installing the main control p.c.b.:

- 13 Make sure the CH (👉) and DHW (👈) temperature adjustment knobs can move freely for the complete range. If not, remove the spindle again as described at step NO TAG, turn the knob half a turn and re-insert the spindle.
- 14 Operate the boiler and close the gas inlet cock so that the boiler goes into the safety lock-out state. Verify the correct operation of the boiler reset button by pressing and releasing it.
- 15 Open the gas inlet cock and check the boiler operates correctly.

## 56 IGNITION PCB REPLACEMENT

- 1 Gain access to the parts located inside the control panel as explained in the the frame 55.
- 2 Remove all the wiring connected to the ignition p.c.b. To disconnect the connectors indicated, delicately flex the hook present on one side of each socket.
- 3 Unscrew the two screws A that hold the ignition p.c.b. on the panel and remove the component.
- 4 Re-assemble in reverse order.
- 5 Check the boiler operates correctly.

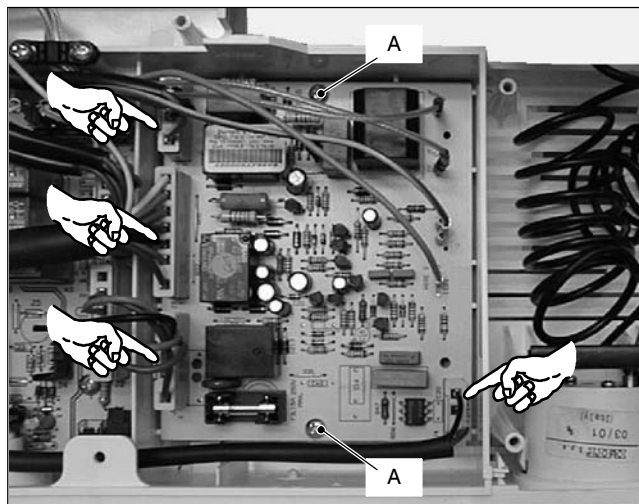

## 57 CH FLOW SWITCH REPLACEMENT

- 1 Disconnect the electrical supply.
- 2 Remove the front casing panel.
- 3 Remove the fork A.
- 4 Open the box B and disconnect the switch.

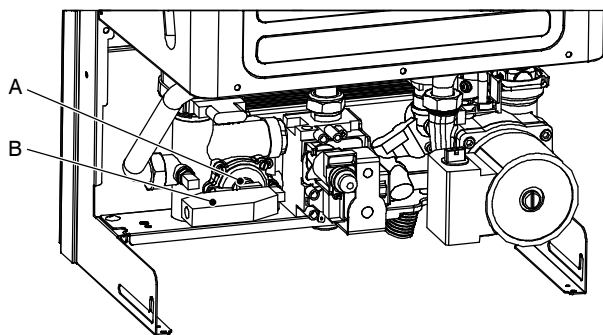

- 5 Re-assemble in reverse order. Refer to the following illustration for the correct wiring connectors on the switch

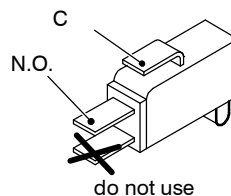

Looking through the switch box B it is possible to verify the position of the spindle C

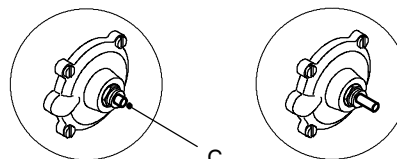

Boiler OFF

Pump operating

## 58 CH FLOW SWITCH MEMBRANE REPLACEMENT

- 1 Disconnect the electrical supply.
- 2 Remove front casing panel (refer to frame 34).
- 3 Close off the isolating cocks of the CH circuit at the bottom of the boiler.
- 4 Release system pressure by opening the main circuit drainage cock.  
**Do not release CH pressure using the pressure relief valve. It may cause debris within the system to foul the valve.**
- 5 Remove the CH circuit flow switch (see frame 57).
- 6 Unscrew the four screws A, open the hydraulic operator and remove the membrane B.
- 7 Re-assemble in reverse order. When assembling the membrane, ensure to place the

concave side of the membrane towards the actuator plate C and locate the reference hole in the membrane over the pressure transfer nipple D.

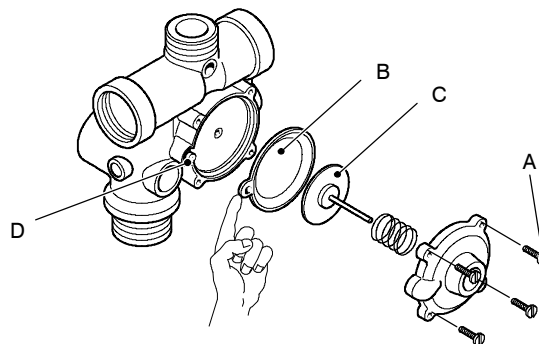

## 59 DHW FLOW SWITCH REPLACEMENT

- 1 Disconnect the electrical supply.
- 2 Remove the front panel of the case (refer to frame 34).
- 3 Disconnect the connector A and remove the sensor by pulling it towards the front of the boiler (the sensor is held in place by means of a spring).
- 4 Replace the sensor and re-assemble in reverse order

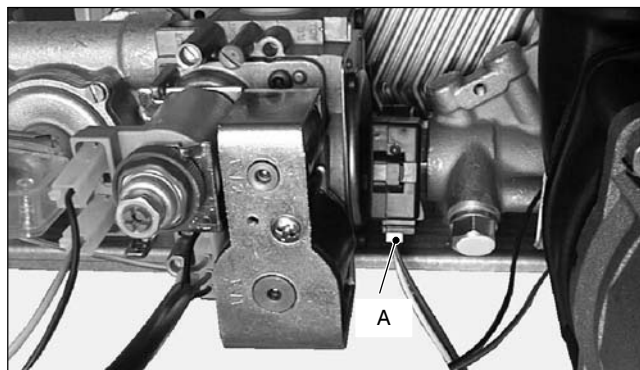

## 60 DHW FILTER AND FLOW LIMITER REPLACEMENT

- 1 Disconnect the electrical supply.
- 2 Remove the front panel of the case and empty the DHW circuit.
- 3 Remove the flow switch A (see frame 59).
- 4 Remove the gas valve (see frame 48).
- 5 Unscrew the plug B and extract the flow switch group.
- 6 To remove the filter C from the flow switch group separate the body D from the plug B by unscrewing it.
- 7 Re-assemble in reverse order.

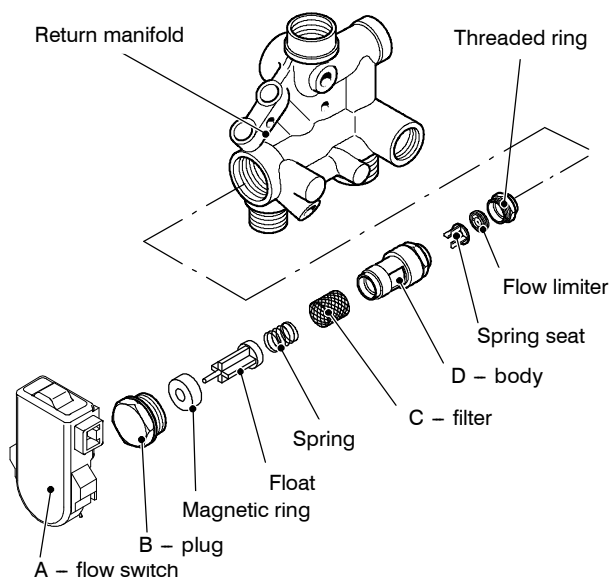

**Attention: the magnetic ring has a magnetic polarity and must be correctly coupled with the spindle of the float.**

To determine the correct orientation of the ring proceed as follows:

- 1 Set the function selector of the boiler in stand-by mode.

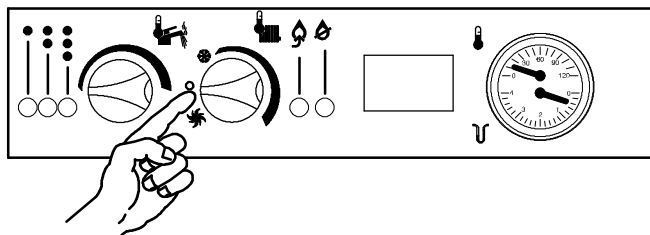

- 2 Restore the mains electricity supply to the boiler.  
**Warning – ensure that all the electric parts and wiring are dry and do not touch other electric parts during the following operations.**
- 3 Hold the flow switch sensor and bring the ring in contact with the sensor as illustrated in the following drawing.

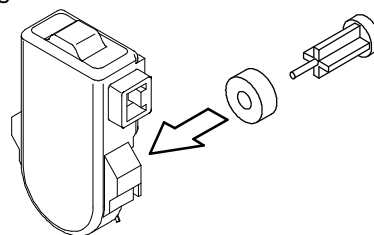

- 4 Observe if the lamp fitted in the sensor body is lit. If not reverse the ring and repeat the previous operation.
- 5 Fit the ring on the spindle of the float in the way that lights the lamp. Ensure filter is correctly positioned and that plug "B" and the threaded ring are screwed tight into the body "D".
- 6 Isolate the boiler from the mains electricity supply and reassemble the parts following the removing sequence in reverse order.

### Flow limiter

The **mini HE C24** model is factory fitted with a 10 litre/min. flow limiter.

The **mini HE C28** model is factory fitted with a 12 litre/min. flow limiter.

**Table 8**

Nominal flow rate (litres/min)	Colour
10	Yellow
12	Brown

- 1 Disconnect the electrical supply.
- 2 Remove the front panel of the case and empty the DHW circuit.
- 3 Remove the flow switch A (see frame 59).
- 4 Remove the gas valve (see frame 48).
- 5 Remove the flow switch group (see frame 60 above)
- 6 Unscrew the threaded ring and extract the flow limiter.
- 7 Fit the correct colour coded limiter (see Table 8 above) and screw the threaded ring tight into the body 'D'.
- 8 Re-assemble in reverse order.

### 61 PRIMARY HEAT EXCHANGER REPLACEMENT

- 1 Disconnect the electrical supply.
- 2 Remove outer and inner casing as explained in frame 34.
- 3 Close off the isolating cocks of the CH circuit at the bottom of the boiler.
- 4 Release system pressure by opening the main circuit drainage cock. **Do not release CH pressure using the pressure relief valve. It may cause debris within the system to foul the valve.**
- 5 Remove the combustion chamber panel A by unscrewing the screws B and removing the fan holder bracket C.
- 6 Remove the screw D and the plate E.
- 7 Loosen the connection F and slightly move the pipe G upwards.
- 8 Remove the clip H and the safety thermostat I. It is not necessary to disconnect it from the wiring.
- 9 Completely unscrew the connection J and move the pipe K downwards freeing it from the heat exchanger connection.
- 10 Remove the clip L.
- 11 Move the pipe M upwards freeing it from the connection and rotate towards right.
- 12 Remove the heat exchanger by sliding it forwards.
- 13 Re-assemble in reverse order.

Fit the clip H with the arrow pointing upwards as illustrated in the drawing.

Do not force the connection F when tightening it.

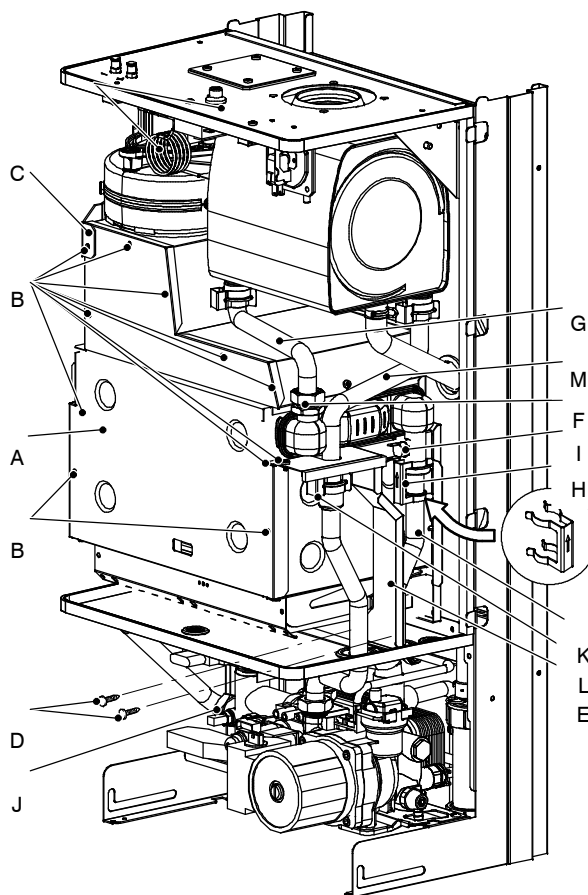

### 62 RECUPERATOR REPLACEMENT

- 1 Disconnect the electrical supply.
- 2 Remove outer and inner casing as explained in frame 34.
- 3 Close off the isolating cocks of the CH circuit at the bottom of the boiler.
- 4 Release system pressure by opening the main circuit drainage cock. **Do not release CH pressure using the pressure relief valve. It may cause debris within the system to foul the valve.**
- 5 Remove the fan A (see frame 51) and the air pressure switch B (see frame 53).
- 6 Remove the flue thermostat C (see frame 45)
- 7 Completely loosen the connection D and slightly move the pipe E upwards.
- 8 Remove the clip F and move the pipe G downwards freeing it from the connection, then turn it towards right.
- 9 Using pliers, remove the spring H moving it downwards and disconnect the rubber pipe I.
- 10 Remove the bracket J by unscrewing the screws that hold it on the frame.
- 11 Rotate the recuperator K as indicated by the arrow and remove it towards the front of the boiler.
- 12 Remove the clip L and the pipe E.
- 13 Reassemble the recuperator carrying out the removal operations in reverse order.

## SERVICING

After reassembling ensure that the fan-exchanger and exchanger-elbow gaskets are correctly mounted and ensure a good sealing.

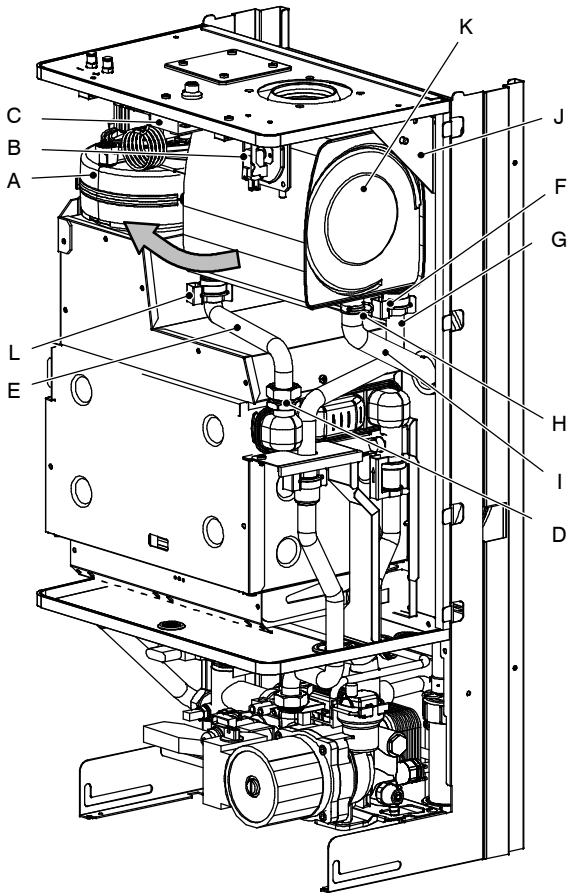

**SERVICING**

## 63 DHW HEAT EXCHANGER REPLACEMENT

- 1 Disconnect the electrical supply.
- 2 Remove outer casing (refer to frame 34).
- 3 Close the isolating cocks of the CH circuit and DHW supply at the bottom of the boiler.
- 4 Release system pressure by opening the main circuit drainage cock.  
**Do not release CH pressure using the pressure relief valve. It may cause debris within the system to foul the valve.**
- 5 Release the pressure of the DHW circuit by opening a hot tap.
- 6 Remove the diverter valve actuator (see frame 64).
- 7 Completely unscrew the two Allen key screws A which hold the exchanger to the brass groups.

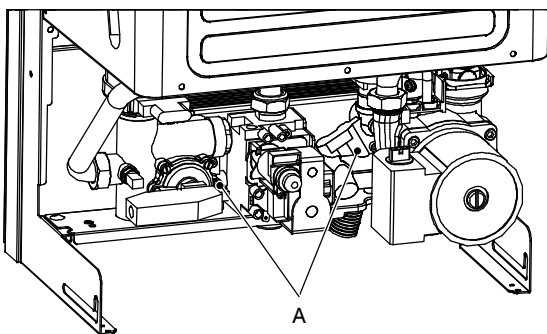

- 8 Move the exchanger towards the rear of the boiler and extract it.
- 9 Re-assemble in the reverse order.

**Attention. When reassembling the exchanger be sure to put the off center location/securing pin indicated towards the left side of the boiler.**

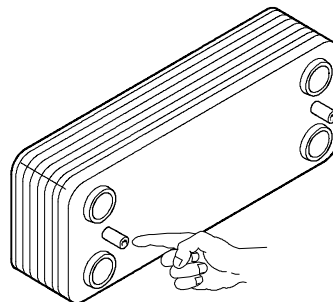

## 64 DIVERTER VALVE ACTUATOR REPLACEMENT

- 1 Disconnect the electrical supply.
- 2 Remove front casing panel (refer to frame 34)..
- 3 Disconnect the connectors A.
- 4 Remove the fixing spring B and remove the actuator C.  
Re-assemble in reverse order.

When reassembling the actuator, refer to the wiring diagram in frame 23 for the correct wiring connection.

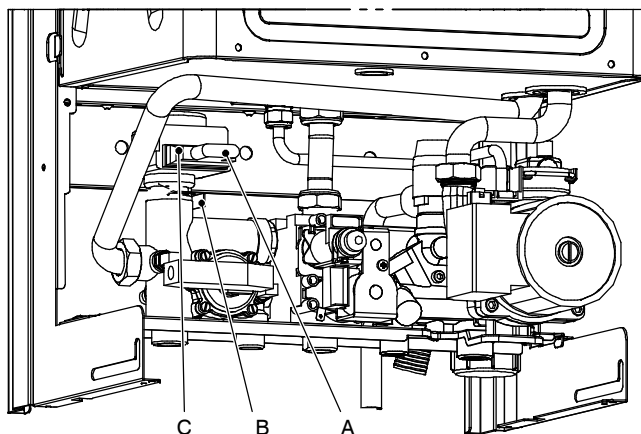

## 65 DIVERTER VALVE INTERNAL PARTS REPLACEMENT

- 1 Disconnect the electrical supply.
- 2 Remove front and left hand casing panels (refer to frame 34).
- 3 Close the isolating cocks of the CH circuit and DHW supply at the bottom of the boiler.
- 4 Release system pressure by opening the main circuit drainage cock.  
**Do not release CH pressure using the pressure relief valve. It may cause debris within the system to foul the valve.**
- 5 Release the pressure of the DHW circuit by opening a hot tap.
- 6 Remove the diverter valve actuator (see frame 64).
- 7 Remove the fork D and remove the primary circuit flow switch E.
- 8 Disconnect both CH and DHW thermistors F.
- 9 Unscrew the connector G, disconnect the CH flow and DHW outlet isolator valves.

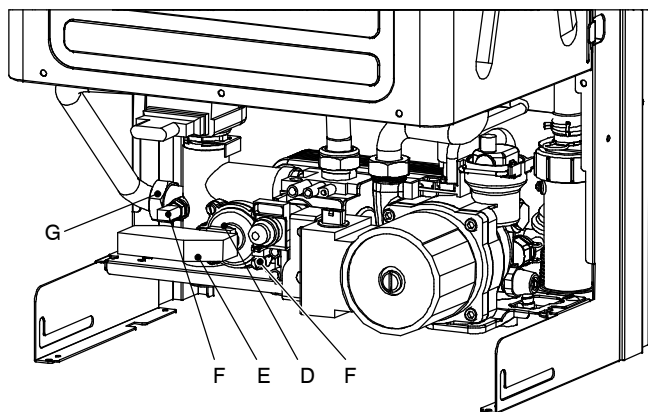

- 10 Remove the DHW heat exchanger (see frame 63).
- 11 Remove the fork H and move away the pipe I.
- 12 Unscrew the screw J and remove the diverter (flow) group.

## 66 PROGRAMMER REPLACEMENT (if fitted)

- 1 Disconnect the electrical supply.
- 2 Gain access to the main control p.c.b. (steps 1 to 4 of frame 55).
- 3 Disconnect the wiring at the programmer.

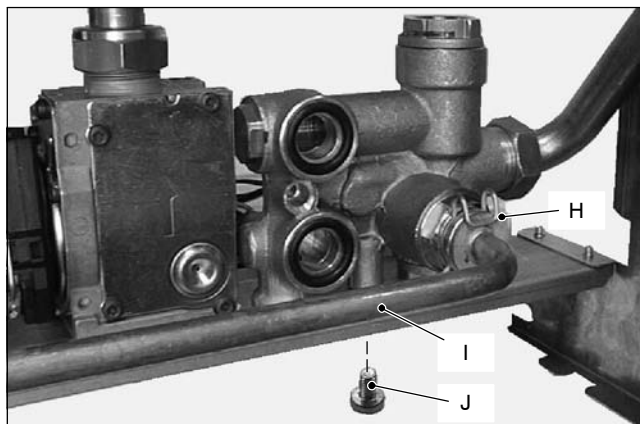

(rear view)

- 13 Refer to the following exploded view to remove the internal parts of the three way diverter valve.



- 14 Re-assemble in reverse order.

- 4 Squeeze the hooks that hold the programmer on the control panel fascia and withdraw the faulty programmer.
  - 5 Re-assemble in reverse order.
- When reassembling the new programmer, refer to the wiring diagram in frame 23 for the correct wiring connection.
- 6 Replace the panels and check the operation of the new programmer.

### 67 CH DRAIN COCK REPLACEMENT

- 1 Disconnect the electrical supply
- 2 Remove front and right hand casing panels (refer to frame 34).
- 3 Close off the isolating cocks of the CH circuit at the bottom of the boiler.
- 4 Release system pressure by opening the main circuit drainage cock.  
**Do not release CH pressure using the pressure relief valve. It may cause debris within the system to foul the valve.**
- 5 Remove the CH drain cock A from the return body.
- 6 Re-assemble in reverse order.

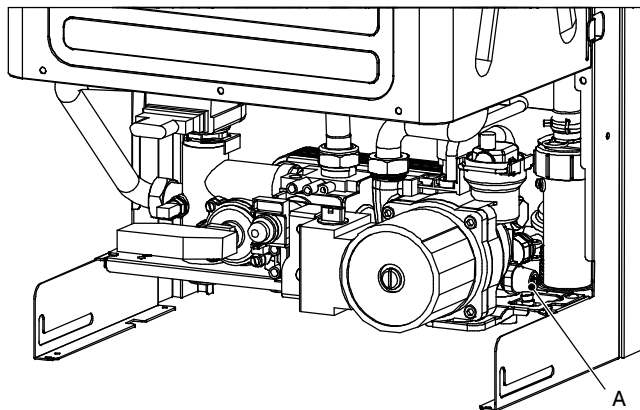

### 68 CONDENSATE TRAP REPLACEMENT

- 1 Disconnect the electrical supply
- 2 Remove front and right hand casing panels (refer to frame 34).
- 3 Disconnect the trap from the draining pipe.
- 4 Using pliers, remove the spring A moving it upwards.
- 5 Remove the nut B and lower the trap.
- 6 Disconnect the wirings from the trap.
- 7 Reassemble carrying out the removal operations in reverse order.

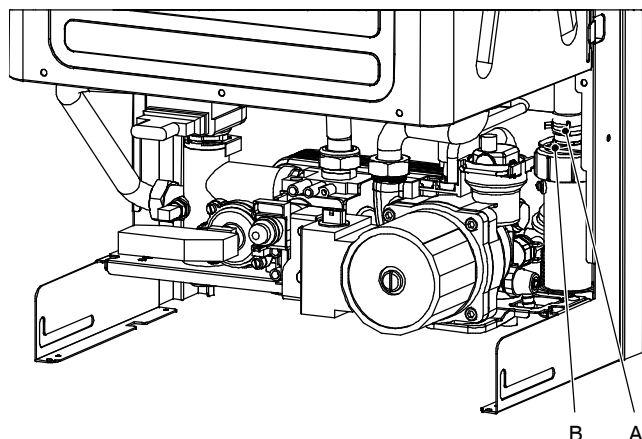

## FAULT FINDING







### 69 MAIN CONTROL P.C.B. OPTICAL INFORMATION

The main control p.c.b. is provided with three lamps (L.E.D. indicators) A that give optical information during the normal operation of the boiler or for service and fault finding purpose.

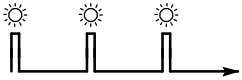
#### Normal operation

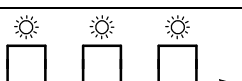
The green lamp on the left is directly visible on the control panel fascia and it gives information during the normal operation of the boiler. The other two lamps are normally switched off.

The following table gives the relationship between the visible lamp indication and its meaning.

 A short pulse every 4 seconds	Boiler in stand-by condition. (function control in  position). Anti-freeze system active.
 1 second ON 1 second OFF	Boiler ON condition (function control in  or  position)
 Very fast pulses (4 per second)	Faulty boiler or irregular operation as: <ul style="list-style-type: none"> <li>- Empty primary circuit</li> <li>- No primary circuit flow</li> <li>- Lack of burner ignition</li> <li>- Excessive temperature in the primary circuit.</li> <li>- Dip-switch 3 left in the OFF position</li> <li>- Faulty temperature probe</li> </ul>

The following table gives a summary of the relationship between each of the possible lamp combinations and their meaning.

	Normally operating boiler
	CH operation
	DHW operation
	Frost protect operation
	DHW operation Excessive temperature on primary circuit
	Faulty CH temperature probe NTC
	Faulty DHW temperature probe NTC
	Faulty primary circuit (no water or absence of flow)
	Lack of burner ignition (no ignition signal from the full sequence ignition device)
	Ignition gas pressure adjustment
	Minimum gas pressure adjustment
Lamp OFF                           Lamp ON                           Flashing lamp, alone or simultaneously with an other lamp.                           Flashing lamp, alternate with another lamp.	

### 70 DIVERTER VALVE ACTUATOR SPINDLE POSITION

To remove the diverter valve actuator refer to frame 64.

The following illustrations indicate the relationship between the electric command coming from the main control p.c.b. and the position of the brass spindle when the boiler operates in either **DHW mode** or **CH mode**.

In both figures the relationship between the position of the actuator and the resistance of the motor windings (the motor must be disconnected from the wiring) is also given.

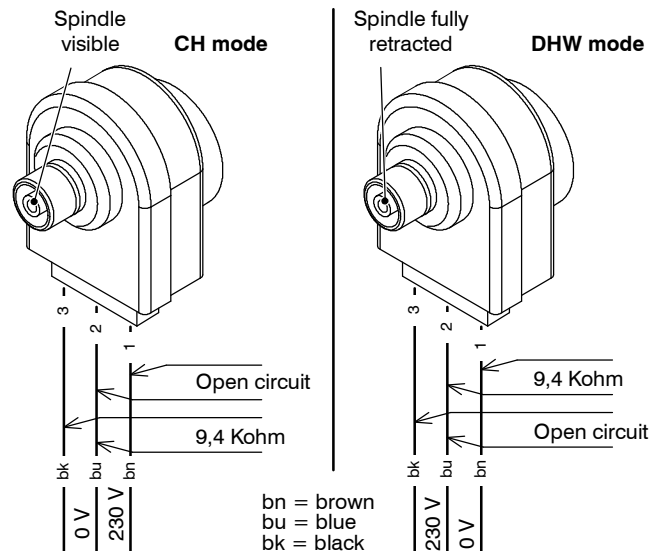

## FAULT FINDING

### 71 FAULT FINDING

**WARNING**

Care must be taken when conducting fault finding tests to guard against the risk of electric shock.

230 Vac is the nominal UK supply voltage. This may vary between 253 Vac and 196 Vac.

When checking continuity ensure power is off to the appliance.

With a fast pulse showing on LED 1 the boiler will continue to operate with a reduced performance in some fault conditions.

Before commencing fault finding please check the following:

- Are all wiring connections OK ?
- Are the function selector settings correct (Refer to frame 27, 28 and 31)
- Are the p.c.b. jumpers correctly placed (Refer to frame 55)

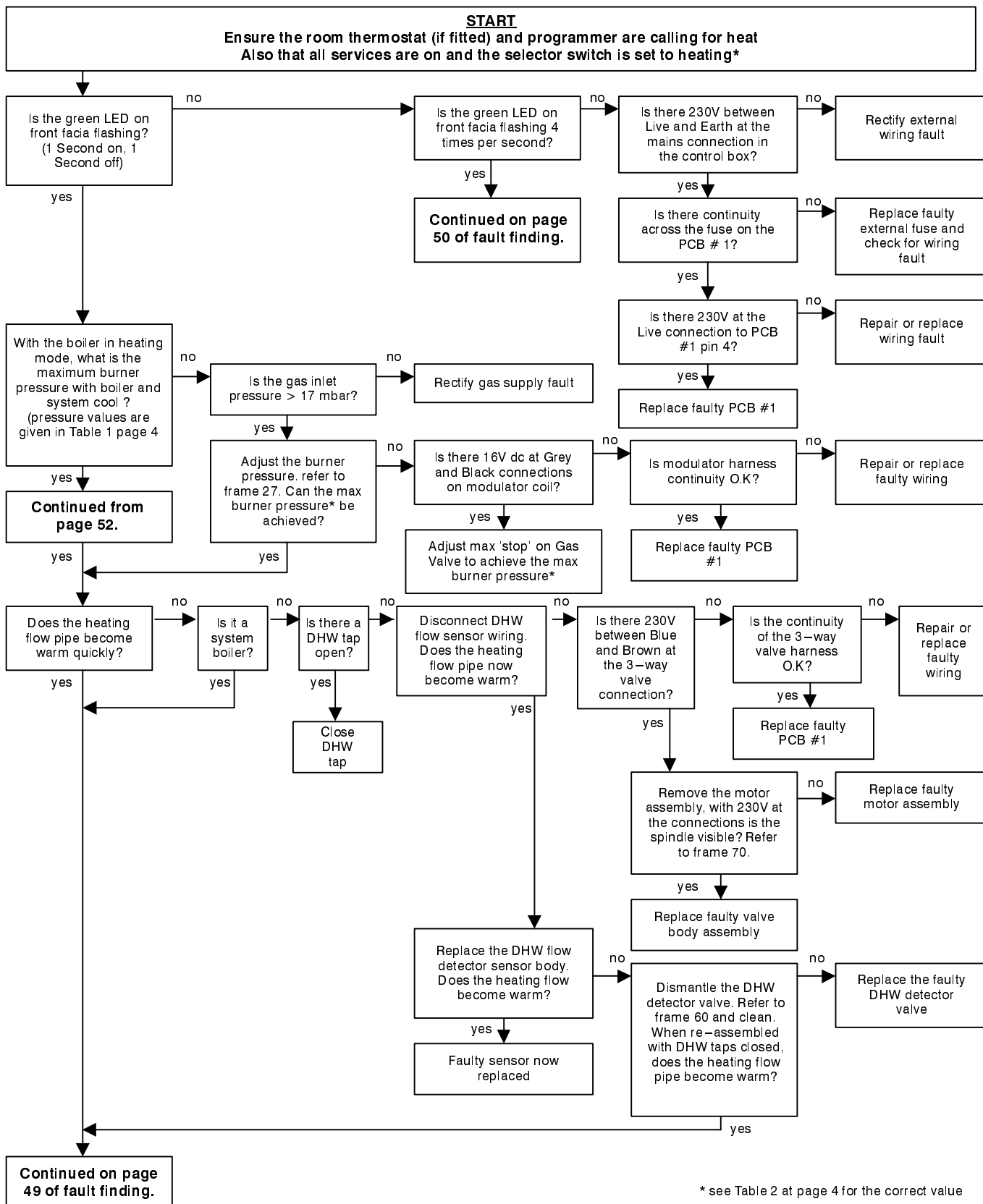

\* see Table 2 at page 4 for the correct value

# FAULT FINDING

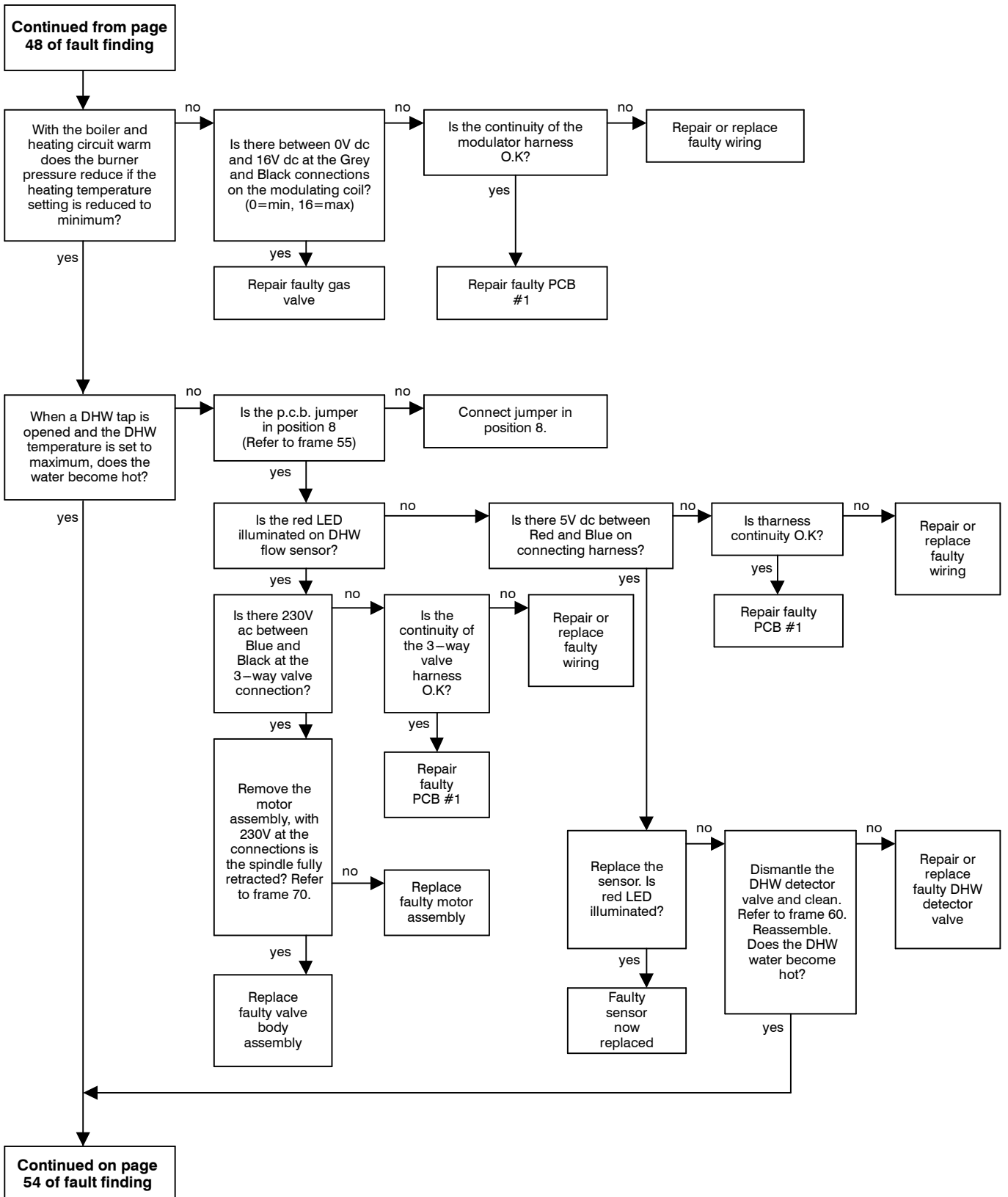

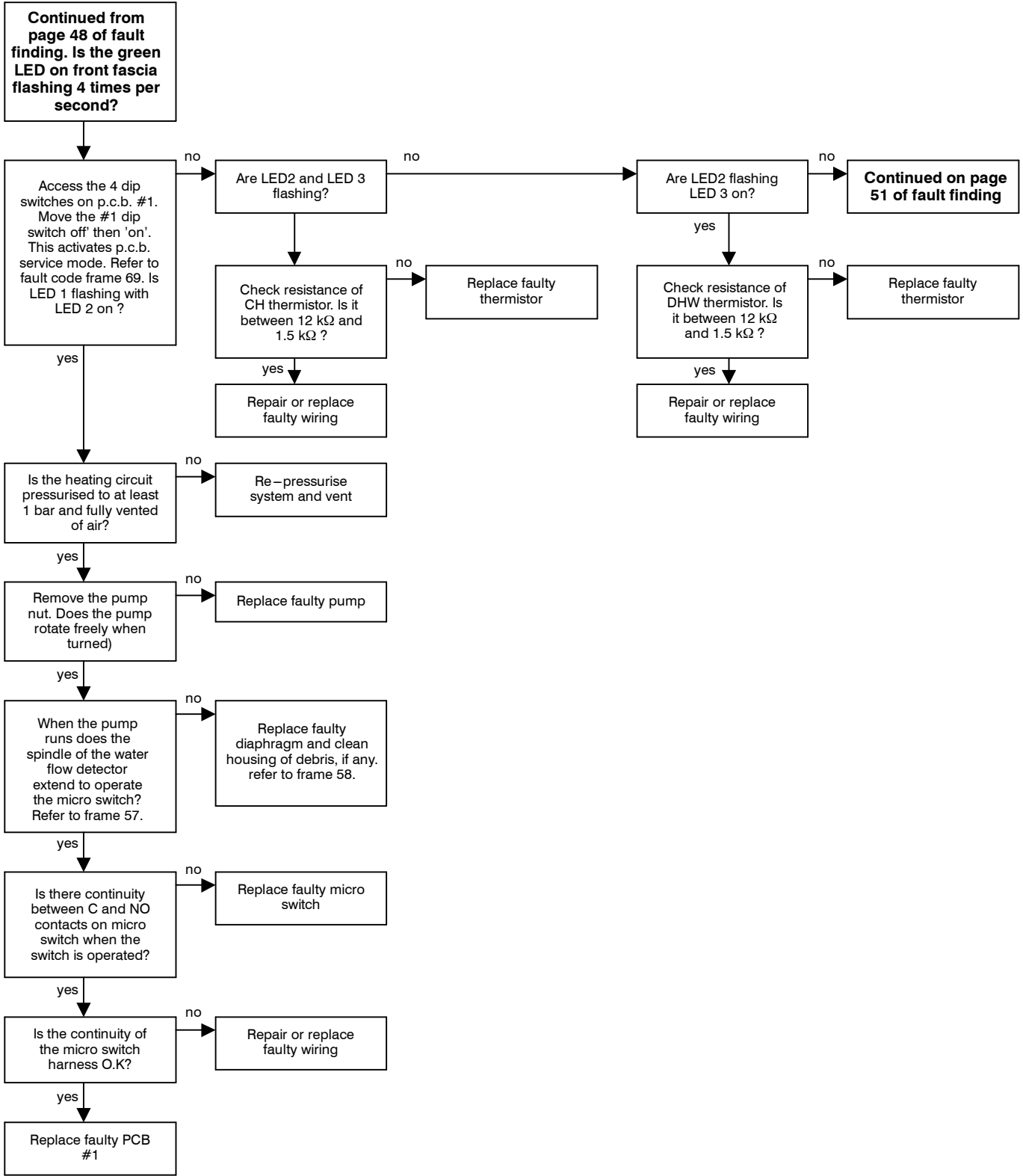

# FAULT FINDING

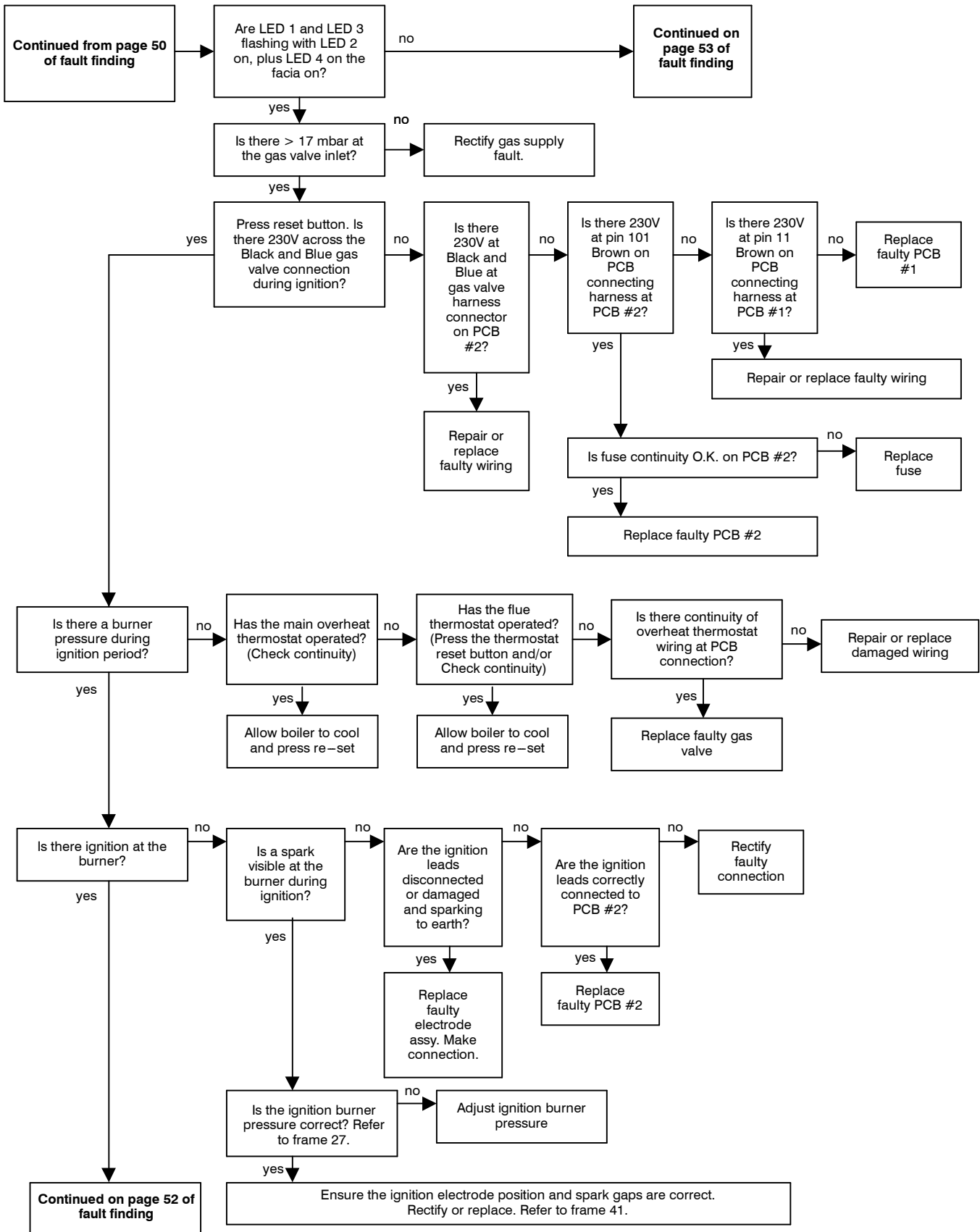

# FAULT FINDING

## FAULT FINDING

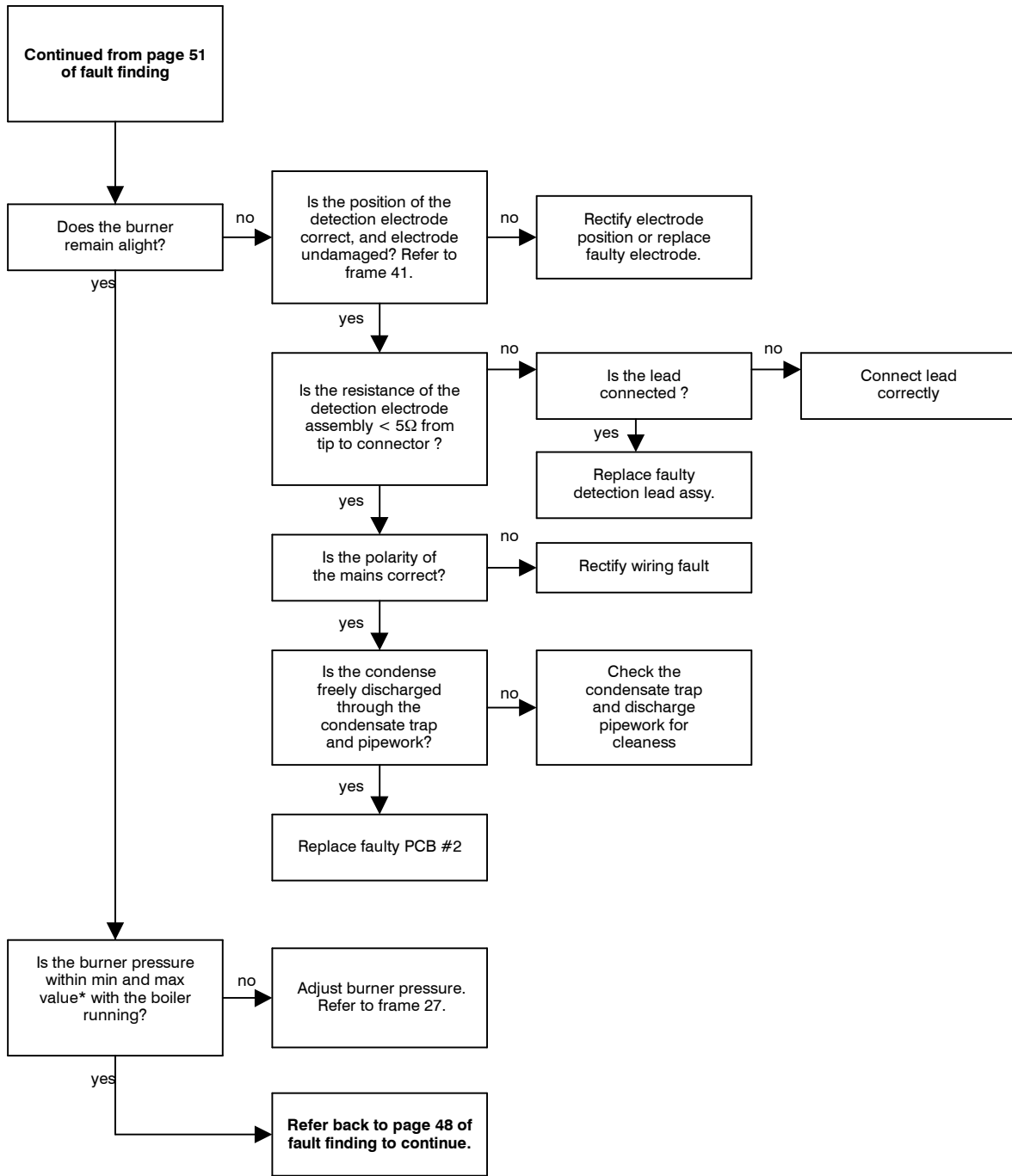

\* see Table 2 at page 4 for the correct value

# FAULT FINDING



**FAULT FINDING**

# FAULT FINDING

## FAULT FINDING

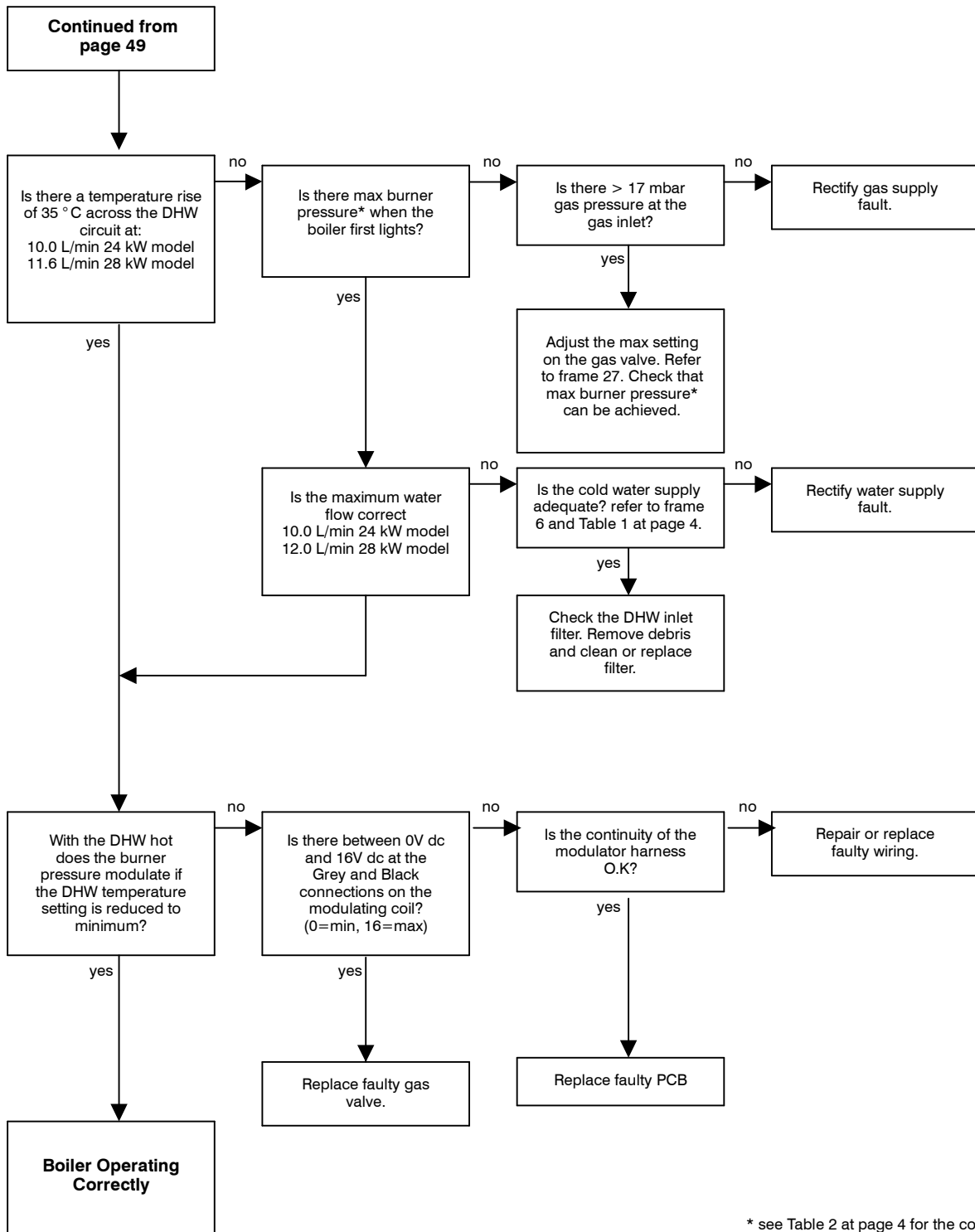

\* see Table 2 at page 4 for the correct value

The following are parts commonly required as replacements, due to damage or expendability. The failure or absence is likely to affect the safety and/or performance of this appliance.

The list is extracted from the British Gas List of Parts which contains all available spare parts.

The full list is held by British Gas, **Caradon Plumbing Ltd.** distributors and merchants.

When ordering spares please quote:

- 1 Boiler model (see Data Plate)
- 2 Appliance G.C. number (see Data Plate)
- 3 Description
- 4 Quantity
- 5 Product No.

Key No.	G.C. No	Description	No. Off/ Boiler	Product No.
1	173–148	Burner (mod. <b>mini HE C24</b> )	1	075427
	173–149	Burner (mod. <b>mini HE C28</b> )	1	075535
2		Main heat exchanger + 'O' rings (mod. <b>mini HE C24</b> )	1	173991
		Main heat exchanger + 'O' rings (mod. <b>mini HE C28</b> )	1	173992
3		Recuperator	1	173993
4	169–069	Injectors for natural gas (mod. <b>mini HE C24</b> )	12	075692
		Injectors for natural gas (mod. <b>mini HE C28</b> )	14	
	E01–156	Injectors for LPG (mod. <b>mini HE C24</b> )	12	173982
		Injectors for LPG (mod. <b>mini HE C28</b> )	14	
5	H21–048	Fan (mod. <b>mini HE C24</b> )	1	173983
	H21–049	Fan (mod. <b>mini HE C28</b> )	1	173984
6	E90–627	Gas valve + gaskets	1	172611
7	169–127	Air pressure switch (mod. <b>mini HE C24</b> )	1	173236
	H08–605	Air pressure switch (mod. <b>mini HE C28</b> )	1	173136
8	E83–013	Safety valve	1	172494
9		Electronic regulation p.c.b.	1	174017
10	E83–142	Full sequence ignition device	1	172548
11	E00–684	Primary circuit flow switch	1	075419
12	E83–082	DHW flow switch (mod. <b>mini HE C24</b> )	1	172503
13	E00–688	Main. flow switch membrane	1	075421
14	E83–101	Overheat thermostat	1	172512
15	E57–048	DHW heat exchanger + 'O' rings (mod. <b>mini HE C24</b> )	1	075460
	E57–049	DHW heat exchanger + 'O' rings (mod. <b>mini HE C28</b> )	1	075540
16	H20–986	Automatic air purger valve	1	173813
17		Pump + 'O' rings	1	174004
18	E83–145	Temperature–pressure gauge	1	172551
19	H21–064	Flue thermostat	1	173985
20	E83–086	Three way diverter valve (electric actuator)	1	172505
21	H21–060	Sealed chamber gaskets kit	1	173986
22	E83–081	Magnetic flow switch and filter	1	172502
23	E83–127	Ignition electrode – left	1	172533
24	E83–126	Ignition electrode – right	1	172532
25	E83–122	Detection electrode	1	172531
26	E69–243	Window (glass + rubber frame)	1	170977
27	169–141	1/2" flat gasket	3	075514
28	169–033	3/4" flat gasket	4	075415
29	169–083	Fuse 1,6 A T	1	172562
30	164–026	Temperature probe (main or DHW circuit)	1	172496
31	H21–052	Side case panel	2	173987

32		Control panel door	1	173988
33		Front case panel	1	173989

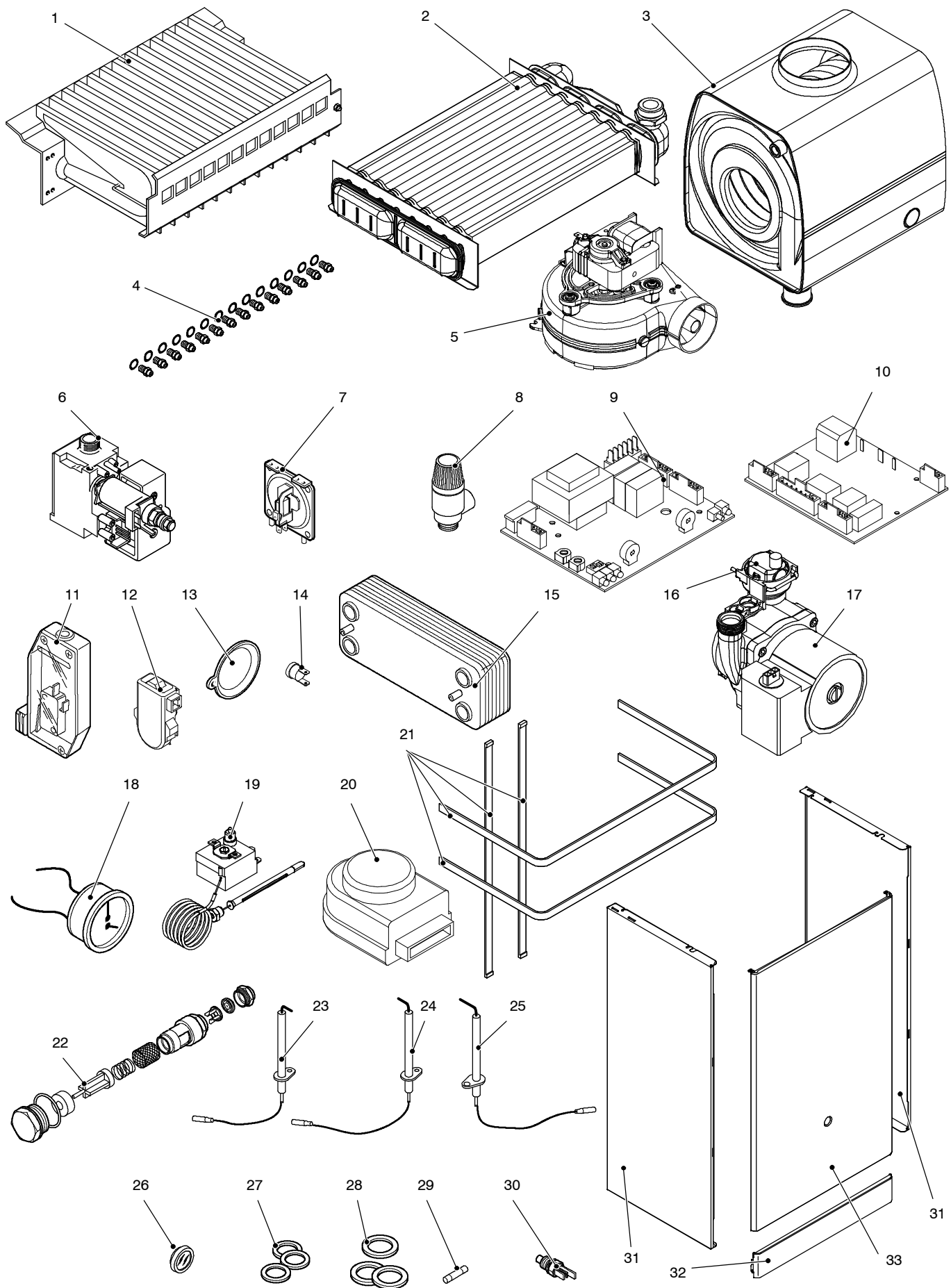

# INSTALLER NOTIFICATION GUIDELINES

In addition a change to Building Regulations (England and Wales) requires the installer to notify when installing a heating appliance, as from 1st April 2005.

**IT IS A REQUIREMENT OF CORGI MEMBERSHIP  
TO REGISTER EVERY GAS APPLIANCE**

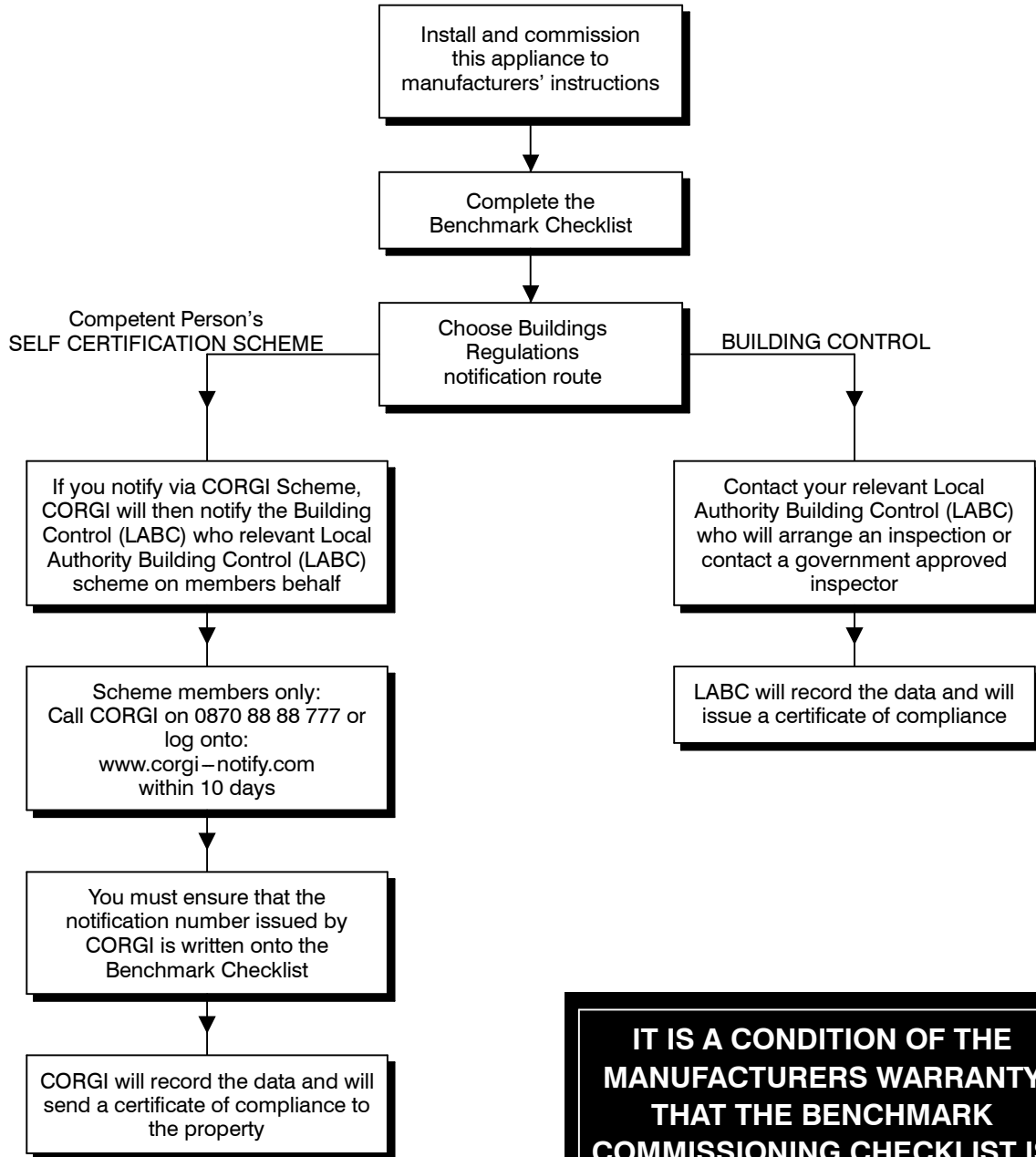

**IT IS A CONDITION OF THE  
MANUFACTURERS WARRANTY  
THAT THE BENCHMARK  
COMMISSIONING CHECKLIST IS  
FULLY COMPLETED AND LEFT  
WITH THE APPLIANCE**



# GAS BOILER COMMISSIONING CHECKLIST

BOILER SERIAL No. \_\_\_\_\_ NOTIFICATION No. \_\_\_\_\_

**CONTROLS** To comply with the Building Regulations, each section must have a tick in one or other of the boxes

TIME & TEMPERATURE CONTROL TO HEATING	ROOM T/STAT & PROGRAMMER/TIMER <input type="checkbox"/>	PROGRAMMABLE ROOMSTAT <input type="checkbox"/>
TIME & TEMPERATURE CONTROL TO HOT WATER	CYLINDER T/STAT & PROGRAMMER/TIMER <input type="checkbox"/>	COMBI BOILER <input type="checkbox"/>
HEATING ZONE VALVES	FITTED <input type="checkbox"/>	NOT REQUIRED <input type="checkbox"/>
HOT WATER ZONE VALVES	FITTED <input type="checkbox"/>	NOT REQUIRED <input type="checkbox"/>
THERMOSTATIC RADIATOR VALVES	FITTED <input type="checkbox"/>	
AUTOMATIC BYPASS TO SYSTEM	FITTED <input type="checkbox"/>	NOT REQUIRED <input type="checkbox"/>

### FOR ALL BOILERS CONFIRM THE FOLLOWING

THE SYSTEM HAS BEEN FLUSHED IN ACCORDANCE WITH THE BOILER MANUFACTURER'S INSTRUCTIONS ?

THE SYSTEM CLEANER USED \_\_\_\_\_

THE INHIBITOR USED \_\_\_\_\_

### FOR THE CENTRAL HEATING MODE, MEASURE & RECORD

GAS RATE \_\_\_\_\_ m<sup>3</sup>/hr \_\_\_\_\_ ft/hr

BURNER OPERATING PRESSURE (IF APPLICABLE)  N/A \_\_\_\_\_ mbar

CENTRAL HEATING FLOW TEMPERATURE \_\_\_\_\_ °C

CENTRAL HEATING RETURN TEMPERATURE \_\_\_\_\_ °C

### FOR COMBINATION BOILERS ONLY

HAS A WATER SCALE REDUCER BEEN FITTED? YES  NO

WHAT TYPE OF SCALE REDUCER HAS BEEN FITTED? \_\_\_\_\_

### FOR THE DOMESTIC HOT WATER MODE, MEASURE & RECORD

GAS RATE \_\_\_\_\_ m<sup>3</sup>/hr \_\_\_\_\_ ft/hr

MAXIMUM BURNER OPERATING PRESSURE (IF APPLICABLE)  N/A \_\_\_\_\_ mbar

COLD WATER INLET TEMPERATURE \_\_\_\_\_ °C

HOT WATER OUTLET TEMPERATURE \_\_\_\_\_ °C

WATER FLOW RATE \_\_\_\_\_ lts/min

### FOR CONDENSING BOILERS ONLY CONFIRM THE FOLLOWING

THE CONDENSATE DRAIN HAS BEEN INSTALLED IN ACCORDANCE WITH THE MANUFACTURER'S INSTRUCTIONS? YES

### FOR ALL INSTALLATIONS CONFIRM THE FOLLOWING

THE HEATING AND HOT WATER SYSTEM COMPLIES WITH PARTS 4 & 7 OF THE BUILDING REGULATIONS

THE APPLIANCE AND ASSOCIATED EQUIPMENT HAS BEEN INSTALLED AND COMMISSIONED IN ACCORDANCE WITH THE MANUFACTURER'S INSTRUCTIONS

IF REQUIRED BY THE MANUFACTURER, HAVE YOU RECORDED A CO/CO<sub>2</sub> RATIO READING? N/A  YES \_\_\_\_\_ CO/CO<sub>2</sub> RATIO

THE OPERATION OF THE APPLIANCE AND SYSTEM CONTROLS HAVE BEEN DEMONSTRATED TO THE CUSTOMER

THE MANUFACTURER'S LITERATURE HAS BEEN LEFT WITH THE CUSTOMER

COMMISSIONING ENG'S NAME PRINT \_\_\_\_\_ CORGI ID No. \_\_\_\_\_

SIGN \_\_\_\_\_ DATE \_\_\_\_\_

# SERVICE INTERVAL RECORD

It is recommended that your heating system is serviced regularly and that you complete the appropriate Service Interval Record Below.

**Service Provider.** Before completing the appropriate Service Interval Record below, please ensure you have carried out the service as described in the boiler manufacturer's instructions. Always use the manufacturer's specified spare part when replacing all controls

**SERVICE 1** DATE \_\_\_\_\_  
ENGINEER NAME \_\_\_\_\_  
COMPANY NAME \_\_\_\_\_  
TEL No. \_\_\_\_\_  
CORGI ID CARD SERIAL No. \_\_\_\_\_  
COMMENTS \_\_\_\_\_  
SIGNATURE \_\_\_\_\_

**SERVICE 2** DATE \_\_\_\_\_  
ENGINEER NAME \_\_\_\_\_  
COMPANY NAME \_\_\_\_\_  
TEL No. \_\_\_\_\_  
CORGI ID CARD SERIAL No. \_\_\_\_\_  
COMMENTS \_\_\_\_\_  
SIGNATURE \_\_\_\_\_

**SERVICE 3** DATE \_\_\_\_\_  
ENGINEER NAME \_\_\_\_\_  
COMPANY NAME \_\_\_\_\_  
TEL No. \_\_\_\_\_  
CORGI ID CARD SERIAL No. \_\_\_\_\_  
COMMENTS \_\_\_\_\_  
SIGNATURE \_\_\_\_\_

**SERVICE 4** DATE \_\_\_\_\_  
ENGINEER NAME \_\_\_\_\_  
COMPANY NAME \_\_\_\_\_  
TEL No. \_\_\_\_\_  
CORGI ID CARD SERIAL No. \_\_\_\_\_  
COMMENTS \_\_\_\_\_  
SIGNATURE \_\_\_\_\_

**SERVICE 5** DATE \_\_\_\_\_  
ENGINEER NAME \_\_\_\_\_  
COMPANY NAME \_\_\_\_\_  
TEL No. \_\_\_\_\_  
CORGI ID CARD SERIAL No. \_\_\_\_\_  
COMMENTS \_\_\_\_\_  
SIGNATURE \_\_\_\_\_

**SERVICE 6** DATE \_\_\_\_\_  
ENGINEER NAME \_\_\_\_\_  
COMPANY NAME \_\_\_\_\_  
TEL No. \_\_\_\_\_  
CORGI ID CARD SERIAL No. \_\_\_\_\_  
COMMENTS \_\_\_\_\_  
SIGNATURE \_\_\_\_\_

**SERVICE 7** DATE \_\_\_\_\_  
ENGINEER NAME \_\_\_\_\_  
COMPANY NAME \_\_\_\_\_  
TEL No. \_\_\_\_\_  
CORGI ID CARD SERIAL No. \_\_\_\_\_  
COMMENTS \_\_\_\_\_  
SIGNATURE \_\_\_\_\_

**SERVICE 8** DATE \_\_\_\_\_  
ENGINEER NAME \_\_\_\_\_  
COMPANY NAME \_\_\_\_\_  
TEL No. \_\_\_\_\_  
CORGI ID CARD SERIAL No. \_\_\_\_\_  
COMMENTS \_\_\_\_\_  
SIGNATURE \_\_\_\_\_

**SERVICE 9** DATE \_\_\_\_\_  
ENGINEER NAME \_\_\_\_\_  
COMPANY NAME \_\_\_\_\_  
TEL No. \_\_\_\_\_  
CORGI ID CARD SERIAL No. \_\_\_\_\_  
COMMENTS \_\_\_\_\_  
SIGNATURE \_\_\_\_\_

**SERVICE 10** DATE \_\_\_\_\_  
ENGINEER NAME \_\_\_\_\_  
COMPANY NAME \_\_\_\_\_  
TEL No. \_\_\_\_\_  
CORGI ID CARD SERIAL No. \_\_\_\_\_  
COMMENTS \_\_\_\_\_  
SIGNATURE \_\_\_\_\_



*the code of practice for the installation  
commissioning & servicing of central heating systems*

### **Technical Training**

The Ideal Boilers Technical Training Centre offers a series of first class training courses for domestic, commercial and industrial heating installers engineers and system specifiers.

For details of courses please ring: . . . . . 01482 498 432

#### **Ideal boilers**

P.O. Box 103, National Ave, Kingston upon Hull  
HU5 4JN. Telephone: 01482 492 251 Fax: 01482 448 858.  
Registration No. London 322 137

**Caradon Ideal Limited** pursues a policy of continuing improvement in the design and performance of its products. The right is therefore reserved to vary specification without notice.



***i* Ideal** BOILERS  
**ENGINEERED FOR PEACE OF MIND**

**Caradon**  
Ideal Limited

***Ideal Installer/Technical Helpline: 01482 498 663***  
***www.idealboilers.com***