



# INSTALLATION & SERVICING

**LOGIC+ HEAT  
H12 H15 H18 H24 H30**

When replacing any part on this appliance, use only spare parts that you can be assured conform to the safety and performance specification that we require. Do not use reconditioned or copy parts that have not been clearly authorised by Ideal Boilers.

**For the very latest copy of literature for specification and maintenance practices visit our website [www.idealboilers.com](http://www.idealboilers.com) where you can download the relevant information in PDF format.**



ERP DATA

	SYMBOL	UNITS	MODEL				
			12	15	18	24	30
Condensing Boiler	n/a	n/a	yes	yes	yes	yes	yes
Low Temperature Boiler	n/a	n/a	no	no	no	no	no
B1 Boiler	n/a	n/a	no	no	no	no	no
Cogeneration Space Heater	n/a	n/a	no	no	no	no	no
Equipped with a Supplementary Heater	n/a	n/a	no	no	no	no	no
Combination Heater	n/a	n/a	no	no	no	no	no
<b>Nominal Heat Output for Space Heating</b>							
Full Load	P <sub>4</sub>	kW	12.1	15.1	18.0	24.3	30.3
Part Load	P <sub>1</sub>	kW	3.9	4.9	5.9	8.0	9.9
<b>Auxiliary Electricity Consumption</b>							
Full Load	e <sub>lmax</sub>	kW	0.020	0.021	0.026	0.042	0.048
Part Load	e <sub>lmin</sub>	kW	0.012	0.012	0.013	0.013	0.013
Standby	P <sub>SB</sub>	kW	0.005	0.005	0.005	0.005	0.005
<b>Seasonal Space Heating Energy Efficiency</b>							
Full Load	η <sub>4</sub>	%	90.0	90.0	89.7	90.0	89.8
Part Load	η <sub>1</sub>	%	97.9	97.8	98.5	98.7	98.2
Standby Loss	P <sub>stby</sub>	kW	0.055	0.055	0.055	0.055	0.055
Ignition	P <sub>ign</sub>	kW	0	0	0	0	0
<b>Emissions</b>							
Nox (Gross)	NO <sub>x, pond Hs</sub>	mg/kWh	10	21	24	28	24
Annual Energy Consumption	Q <sub>HE</sub>	GJ	38	47	56	75	93
Sound Power Level, Indoors	L <sub>WA</sub>	dB	36	38	41	47	49



# PRODUCT FICHE

## LOGIC + HEAT H BOILER

Ideal Boilers

### ERP DATA

	SYMBOL	UNITS	MODEL					
			12	15	18	24	30	
Condensing boiler				Yes				
Seasonal Space heating efficiency class				A				
Rated heat output		kW	12	15	18	24	30	
Seasonal space heating energy efficiency	$\eta_s$	%	93*	93*	93*	94*	93*	
Annual energy consumption	$Q_{HE}$	GJ	38	47	56	75	93	
Sound power level, indoors	$L_{WA}$	dB	36	38	41	47	49	

<b>Seasonal Space Heating Energy Efficiency of the Boiler</b>	*%  <b>A</b>																
<b>Temperature control (from fiche of temperature control)</b>	%  <b>B</b>																
<table border="1" style="width: 100%; border-collapse: collapse;"> <thead> <tr> <th style="text-align: center;">Class I</th> <th style="text-align: center;">Class II</th> <th style="text-align: center;">Class III</th> <th style="text-align: center;">Class IV</th> <th style="text-align: center;">Class V</th> <th style="text-align: center;">Class VI</th> <th style="text-align: center;">Class VII</th> <th style="text-align: center;">Class VIII</th> </tr> </thead> <tbody> <tr> <td style="text-align: center;">1%</td> <td style="text-align: center;">2%</td> <td style="text-align: center;">1.5%</td> <td style="text-align: center;">2%</td> <td style="text-align: center;">3%</td> <td style="text-align: center;">4%</td> <td style="text-align: center;">3.5%</td> <td style="text-align: center;">5%</td> </tr> </tbody> </table>	Class I	Class II	Class III	Class IV	Class V	Class VI	Class VII	Class VIII	1%	2%	1.5%	2%	3%	4%	3.5%	5%	
Class I	Class II	Class III	Class IV	Class V	Class VI	Class VII	Class VIII										
1%	2%	1.5%	2%	3%	4%	3.5%	5%										

### Solar Contribution (from fiche of solar device)

Collector Size  
(in m<sup>2</sup>)

Tank Volume  
(in m<sup>3</sup>)

Collector Efficiency  
(in %)

Tank rating  
A\* = 0.95  
A = 0.91  
B = 0.86  
C = 0.83  
D-G = 0.81

= ('III' x  + 'IV' x  ) x 0.9 x (  / 100 x  ) = % **C**

Seasonal Space Heating Energy Efficiency of Package

**TOTAL: A+B+C=**

% **A+B+C**

### Seasonal Space Heating Energy Efficiency Class of Package

<b>G</b>	<b>F</b>	<b>E</b>	<b>D</b>	<b>C</b>	<b>B</b>	<b>A</b>	<b>A+</b>	<b>A++</b>	<b>A+++</b>
< 30%	≥ 30%	≥ 34%	≥ 36%	≥ 75%	≥ 82%	≥ 90%	≥ 98%	≥ 125%	≥ 150%

The energy efficiency of the package of products provided for in this document may not correspond to its actual energy efficiency once installed in a building, as the efficiency is influenced by further factors such as heat loss in the products in relation to the building size and its characteristics





## NOTES FOR THE INSTALLER

**FOR ANY TECHNICAL QUERIES PLEASE RING THE IDEAL  
INSTALLER HELPLINE : 01482 498704**

**NOTE. BOILER RESTART PROCEDURE -**

To restart the boiler press the RESTART button. The boiler will repeat the ignition sequence if a heat demand is present.

## DOCUMENT AMENDMENTS

Relevant Installation changes implemented in this book from Mod Level .....A09 (Aug 18) to A10 (Feb 19)

---

**ERP Data (Page 2)**

Updated Nox Emissions figures

**Section 2.19 Condensate Drain**

Updated information and figures

**Section 3.1 & Page 64**

Maximum and Minimum rates information

---

*Ideal Boilers reserve the right to vary specification without notice*

---



# CONTENTS

<b>1</b>	<b>GENERAL.....</b>	<b>10</b>	2.25	Commissioning & Testing.....	39
1.1	Introduction .....	10	2.26	Initial Lighting .....	40
1.2	Operation .....	10	2.27	General Checks .....	41
1.3	Safe Handling.....	10	2.28	Restart Procedure.....	41
1.4	Optional Extra Kits .....	10	2.29	Accessing The Installer Mode .....	42
1.5	Safety.....	11	2.30	Handing Over.....	42
1.6	Safe Handling Of Substances.....	11	<b>3</b>	<b>SERVICING .....</b>	<b>43</b>
1.7	Location Of Boiler .....	11	3.1	Servicing Schedule .....	43
1.8	Gas Supply.....	12	3.2	Boiler Front Panel Removal / Replacement.....	44
1.9	Flue Installation .....	12	3.3	Fan & Venturi Assembly Removal And Cleaning .....	44
1.10	Terminal.....	13	3.4	Burner Removal And Cleaning.....	45
1.11	Air Supply.....	13	3.5	Cleaning the Condensate Trap/Siphon .....	45
1.12	Water Circulation System.....	13	3.6	Cleaning the Heat Exchanger .....	46
1.13	Boiler Control Interlocks.....	13	3.7	Reassembly .....	46
1.14	Electrical Supply.....	13	3.8	Replacement Of Components.....	47
1.15	Condensate Drain .....	13	3.9	Fan Replacement.....	47
1.16	Boiler Dimensions, Services & Clearances.....	14	3.10	Burner Injector Replacement .....	48
1.17	Open Vent System Requirements.....	15	3.11	Burner Replacement .....	48
1.18	Schematic Pipework And System Balancing.....	15	3.12	Control & Return Thermistor Replacement.....	49
1.19	Low Head & Large Systems With Extensive Pipe Runs ..	16	3.13	Ignition Electrode Replacement .....	49
1.20	Sealed System Requirements.....	16	3.14	Flame Detection Electrode Replacement.....	50
1.21	System Balancing .....	18	3.15	Spark Generator Replacement .....	50
1.22	Water Treatment.....	18	3.16	Gas Control Valve Replacement.....	51
<b>2</b>	<b>INSTALLATION .....</b>	<b>19</b>	3.17	Condensate Trap/Siphon Replacement.....	51
2.1	Boiler Assembly - Exploded View.....	19	3.18	PCB Replacement.....	52
2.2	Unpacking .....	20	3.19	Water Flow Switch Head Replacement .....	52
2.3	Front Panel Removal .....	21	3.20	Heat Engine Replacement .....	53
2.4	Wall Mounting Template .....	22	<b>4</b>	<b>FAULT FINDING .....</b>	<b>54</b>
2.5	Preparing The Wall.....	22	4.1	Fault Finding Chart Main Menu.....	54
2.6	Fitting The Wall Mounting Plate (Turret Option).....	22	4.2	'L1' - Flow Temp O'heat or No Water Flow Lockout ...	55
2.7	Mounting The Boiler .....	22	4.3	'L2' - Ignition Lockout .....	55
2.8	Determining the Flue Length & Flue Packs Req'd .....	23	4.4	'L6' - False Flame Lockout .....	56
2.9	Cutting & Setting The Flue Length .....	25	4.5	'Fd' - No Water Flow.....	56
2.10	Installing The Flue.....	26	4.6	'F2' Or 'Fn' or 'Ln' - Flame Loss .....	56
2.11	Rear Flue Outlet Kit (55/80) Assy - Exploded View....	27	4.7	'F3' - Fan Fault .....	56
2.12	Terminal Wall Seal Assembly / Positioning.....	27	4.8	'L4' Or 'F4' - Control / No Flow Thermistor Fault .....	57
2.13	Setting The Rear Flue Length.....	27	4.9	'F5 Or L5' - Return Thermistor Fault .....	57
2.14	Fitting The Wall Plate / Rear Flue Terminal Assy .....	28	4.10	'F6' - Outside Sensor Fault.....	57
2.15	Mounting The Boiler - Rear Flue Outlet Kit (55/80)....	29	4.11	No CH Operation.....	58
2.16	Fitting The Optional Roof Flue Kit (Flat Or Pitched)...	30	4.12	No Display.....	58
2.17	Flue Terminal Position .....	31	4.13	No DHW .....	58
2.18	Assembling The Roof Flue Kit.....	32	<b>5</b>	<b>SPARE PARTS .....</b>	<b>59</b>
2.19	Condensate Drain .....	33	<b>6</b>	<b>BENCHMARK &amp; COMMISSIONING .....</b>	<b>60</b>
2.20	Connections .....	35			
2.21	Electrical Connections.....	35			
2.22	Installer Wiring .....	36			
2.23	Installer Wiring Plan Diagrams.....	37			
2.24	Wiring Diagram .....	38			

## SECTION 1 - GENERAL

**Table 1 - General Data**

		12	15	18	24	30
Gas supply		2H - G20 - 20mbar				
Gas Supply Connection		15mm copper compression				
Injector Size	mm	4.15	4.15	4.15	4.15	4.65
Flow Connection	Central Heating	22mm copper compression				
Return Connection	Central Heating	22mm copper compression				
Flue Terminal Diameter - Turret	mm	100				
Flue Terminal Diameter - Rear Flue Outlet (55/80)	mm	80				
Average Flue Temp-Mass Flow Rate		56°C - 5g/s	56°C - 6g/s	58°C - 8g/s	63°C - 10g/s	69°C - 13g/s
CO <sub>2</sub> Content (± 0.7)	Max. CH	9.1%	9.3%	9.5%	9.5%	9.3%
	Min. CH	8.5%	8.8%	8.9%	8.8%	8.8%
Max. static water head	m (ft.)	30.5 (100)				
Min. static water head	m (ft.)	0.45 (1.5)				
Max. Working Pressure (Sealed Systems)	bar (lb/in <sup>2</sup> )	2.5 (36.3)				
Electrical Supply		230 V ~ 50 Hz.				
Power Consumption	W	16	20	24	39	47
Fuse Rating		External : 3A Internal : T4H ARC L250 V				
Water content	litre (gal)	1.2 (0.26)				
Packaged Weight	kg	26.2				
Maximum Installation Weight	kg	22.7				
Boiler Casing Size	Height	700				
	Width	395				
	Depth	278				

**Table 2 - Performance Data - Central Heating**

		12		15		18		24		30		
		MIN	MAX	MIN	MAX	MIN	MAX	MIN	MAX	MIN	MAX	
Boiler Input :												
Boiler Input 'Q'	Nett CV	kW	4.9	12.1	4.9	15.1	4.9	18.1	4.9	24.3	6.1	30.4
	Gross CV	kW	5.4	13.4	5.4	16.6	5.4	20.1	5.4	27.0	6.7	33.7
Gas Consumption		m <sup>3</sup> /h	0.500	1.246	0.500	1.537	0.500	1.872	0.500	2.512	0.623	3.135
Boiler Output :												
Non Condensing		kW	4.8	12.0	4.8	15.0	4.8	18.0	4.8	24.2	6.1	30.3
70°C Mean Water temp.												
Condensing		kW	5.1	13.0	5.1	15.9	5.1	19.1	5.1	25.6	6.4	31.0
40°C Mean Water temp.												
Seasonal efficiency* (SEDBUK) 2005			91.1%		91.2%		91.1%		91.2%		91.1%	
Seasonal efficiency* (SEDBUK) 2009			89.4%		89.4%		89.7%		89.7%		89.6%	
NOx Classification			CLASS 6									

\* The value is used in the UK Government's Standard Assessment Procedure (SAP) for energy rating of dwellings. The test data from which it has been calculated have been certified by a notified body.

**Note.** Gas consumption is calculated using a calorific value of 38.7 MJ/m<sup>3</sup> gross or 34.9 MJ/m<sup>3</sup> nett

To obtain the gas consumption at a different calorific value:

- For l/s - divide the gross heat input (kW) by the gross C.V. of the gas (MJ/m<sup>3</sup>)
- For Btu/h - multiply the gross heat input (kW) by 26.8
- For ft<sup>3</sup>/h - divide the gross heat input (Btu/h) by the gross C.V. of the gas (Btu/ft<sup>3</sup>)
- For m<sup>3</sup>/h - multiply l/s by 3.6

### Key to symbols

**GB** = United Kingdom    **IE** = Ireland    (Countries of destination)

**PMS** = Maximum operating pressure of water

**C<sub>13</sub> C<sub>33</sub> C<sub>53</sub>** = A room sealed appliance designed for connection via ducts to a horizontal or vertical terminal, which admits fresh air to the burner and discharges the products of combustion to the outside through orifices which, in this case, are concentric. The fan is up stream of the combustion chamber.

**I<sub>2H</sub>** = An appliance designed for use on 2nd Family gas, Group H only.

**IDEAL LOGIC + HEAT H**

Natural Gas only

Boiler size	G.C. Appliance No. (Benchmark No.)
12	41-750-82
15	41-750-83
18	41-750-84
24	41-750-85
30	41-750-86

Destination Country: GB, IE

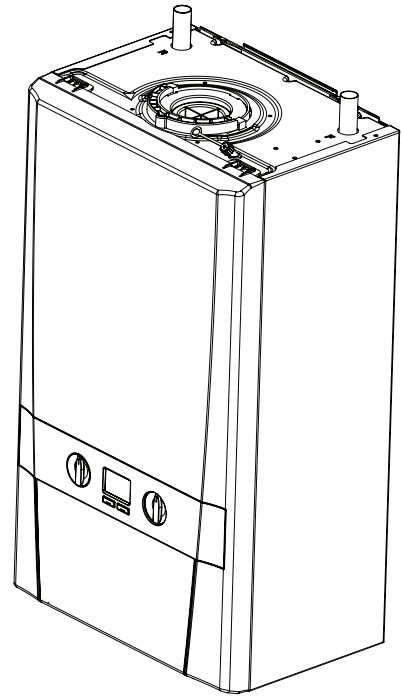

For GB, to comply with Building Regulations Part L1 (Part 6 in Scotland) the boiler should be fitted in accordance with the manufacturer's instructions. Self-certification that the boiler has been installed to comply with Building Regulations can be demonstrated by completing and signing the Benchmark Commissioning Checklist.

Before installing this boiler, read the Code of Practice sheet at the rear of this book.

**BENCHMARK COMMISSIONING CHECKLIST DETAILS**

<b>Boiler</b>	<b>Page</b>	<b>Page</b>	
Make and model.....	9	Burner operating pressure .....	n/a
Appliance serial no. on data badge .....	Front Cover	Central heating flow temp. ....	measure and record
SEDBUK No. %.....	8	Central heating return temp. ....	measure and record
<b>Controls</b>		<b>For combination boilers only</b>	
Time and temperature control to heating .....	37	Scale reducer .....	18
Time and temperature control to hot water .....	37	<i>Hot water mode</i>	
Heating zone valves.....	n/a	Heat input.....	to be calculated
TRV's.....	13	Max. operating burner pressure .....	n/a
Auto bypass .....	13	Max. operating water pressure.....	measure & record
Boiler interlock.....	13	Cold water inlet temp .....	measure & record
<b>For .....</b>	<b>all boilers</b>	Hot water outlet temp. ....	measure & record
Flushing to BS.7593.....	18	Water flow rate at max. setting.....	measure & record
Inhibitor .....	18	<b>For condensing boilers only</b>	
<i>Central heating mode</i>		Condensate drain.....	33
Heat input.....	to be calculated	<b>For all boilers:</b>	<i>complete, sign &amp; hand over to customer</i>
			For assistance see Technical Helpline on the back page

**NOTE TO THE INSTALLER: COMPLETE THE BENCHMARK COMMISSIONING CHECKLIST AND LEAVE THESE INSTRUCTIONS WITH APPLIANCE**



## 1.1 INTRODUCTION

The **Logic + Heat H** range of boilers are wall mounted, full sequence, automatic spark ignition, low water content, fanned flue, high efficiency, condensing, heating only gas boilers.

**Note.** *Due to the high efficiency of the boiler a plume of water vapour will form at the terminal during operation.*

Central heating (CH) output is fully modulating with a range of:

12	4.8 to 12kW
15	4.8 to 15kW
18	4.8 to 18kW
24	4.8 to 24.2kW
30	6.1 to 30.3kW

A variable CH temperature control is fitted on the user control.

The boiler includes as standard:

- Boiler frost protection

**Notes.** *The appliance must be wired with a permanent live supply, or the boiler frost protection will not operate.*

*The boiler warranty will be invalid if these requirements are not complied with.*

The boiler casing is of white painted mild steel with a polymer front panel.

The boiler temperature control is visibly located in the control panel on the front of the boiler.

The heat exchanger is manufactured from cast aluminium.

Note that these boilers cannot be used on systems which include gravity circulation.

The boiler is suitable for connection to fully pumped open vented or sealed water systems. Adequate arrangements for completely draining the system by provision of drain cocks **MUST** be provided in the installation pipework.

Pipework from the boiler is routed upwards.

A rear flue outlet kit (55/80) is available which provides a compact installation.

### Data Plate

The boiler model and serial number can be located on the bottom of the boiler casing, shown in Section 1.16 - Condensate & Gas Connection Diagram.

## 1.2 OPERATION

When there is a demand for CH, the heating system is supplied at the selected temperature of between 30°C and 80°C.

The boiler features a comprehensive diagnostic system which gives detailed information on the boiler status when operating, and performance of key components to aid commissioning and fault finding.

## 1.3 SAFE HANDLING

This boiler may require 2 or more operatives to move it to its installation site, remove it from its packaging base and during movement into its installation location. Manoeuvring the boiler may include the use of a sack truck and involve lifting, pushing and pulling.

Caution should be exercised during these operations.

Operatives should be knowledgeable in handling techniques when performing these tasks and the following precautions should be considered:

- Grip the boiler at the base.
- Be physically capable.
- Use personal protective equipment as appropriate, e.g. gloves, safety footwear.

During all manoeuvres and handling actions, every attempt should be made to ensure the following unless unavoidable and/or the weight is light.

- Keep back straight.
- Avoid twisting at the waist.
- Avoid upper body/top heavy bending.
- Always grip with the palm of the hand.
- Use designated hand holds.
- Keep load as close to the body as possible.
- Always use assistance if required.

## 1.4 OPTIONAL EXTRA KITS

Please visit [www.idealboilers.com](http://www.idealboilers.com) to access the Flue and Accessories Guide for this boiler.

# SECTION 1 - GENERAL

## 1.5 SAFETY

### Current Gas Safety (installation and use) regulations or rules in force:

The appliance is suitable only for installation in GB and IE and should be installed in accordance with the rules in force.

In GB, the installation must be carried out by a Gas Safe Registered Engineer. It must be carried out in accordance with the relevant requirements of the:

- Gas Safety (Installation and Use) Regulations
- The appropriate Building Regulations, either The Building Regulations, The Building Regulations (Scotland), Building Regulations (Northern Ireland)
- The Water Fittings Regulations or Water byelaws in Scotland
- The Current I.E.E. Wiring Regulations

Where no specific instructions are given, reference should be made to the relevant British Standard Code of Practice.

In IE, the installation must be carried out by a Registered Gas Installer (RGII) and installed in accordance with the current edition of I.S.813 "Domestic Gas Installations", the current Building Regulations and reference should be made to the current ETCI rules for electrical installation.

Detailed recommendations are contained in the following British Standard Codes of Practice:

- BS. 5440:1** Flues (for gas appliances of rated input not exceeding 70 kW).
- BS. 5440:2** Ventilation (for gas appliances of rated input not exceeding 70 kW).
- BSEN. 12828:2003** Heating Systems in buildings: Design for water based heating systems.
- BSEN 12831:2003** Heating Systems in buildings: Method for calculation of the design heat load.
- BSEN 14336:2004** Heating Systems in buildings: Installation and commissioning of water based heating systems.
- BS. 5546** Installation of gas hot water supplies for domestic purposes (2nd Family Gases)
- BS. 6798** Installation of gas fired hot water boilers of rated input not exceeding 70 kW.
- BS. 6891** Low pressure installation pipes.

### Health & Safety Document No. 635.

### The Electricity at Work Regulations, 1989.

The manufacturer's notes must NOT be taken, in any way, as overriding statutory obligations.

**IMPORTANT.** These appliances are CE certificated for safety and performance. It is, therefore, important that no external control devices, e.g. flue dampers, economisers etc., are directly connected to these appliances unless covered by these Installation and Servicing Instructions or as otherwise recommended by **Ideal Boilers** in writing. If in doubt please enquire.

Any direct connection of a control device not approved by **Ideal Boilers** could invalidate the certification and the normal appliance warranty. It could also infringe the Gas Safety Regulations and the above regulations.

## 1.6 SAFE HANDLING OF SUBSTANCES

No asbestos, mercury or CFCs are included in any part of the boiler or its manufacture.

## 1.7 LOCATION OF BOILER

The boiler must be installed on a flat and vertical internal wall, capable of adequately supporting the weight of the boiler and any ancillary equipment.

The boiler may be fitted on a combustible wall and insulation between the wall and the boiler is not necessary, unless required by the local authority.

For electrical safety reasons there must be no access available from the back of the boiler.

**The boiler must not be fitted outside.**

### Timber Framed Buildings

If the boiler is to be fitted in a timber framed building it should be fitted in accordance with the Institute of Gas Engineering document IGE/UP/7:2006 - Edition 2.

### Bathroom Installations

This appliance is rated **IP20**.

The boiler may be installed in any room or internal space, although particular attention is drawn to the requirements of the current IEE (BS.7671) Wiring Regulations and the electrical provisions of the building regulations applicable in Scotland, with respect to the installation of the boiler in a room or internal space containing a bath or shower. For IE reference should be made to the current ETCI rules for electrical installations and I.S. 813:2002.

If the appliance is to be installed in a room containing a bath or shower then, providing water jets are not going to be used for cleaning purposes (as in communal baths/showers), the appliance must be installed beyond Zone 2, as detailed in BS.7671.

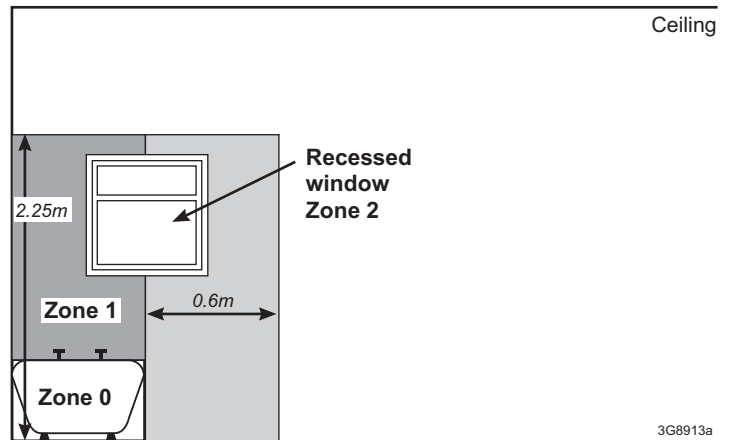

### Compartment Installations

A compartment used to enclose the boiler should be designed and constructed specially for this purpose.

An existing cupboard or compartment may be used, provided that it is modified for the purpose.

Braces for compartments must be easily removable for service access.

In both cases, details of essential features of cupboard / compartment design, including airing cupboard installation, are to conform to the following:

- BS 6798 (No cupboard ventilation is required - see 'Air Supply' for details).
- The position selected for installation MUST allow adequate space for servicing in front of the boiler.
- For the minimum clearances required for safety and subsequent service, see the wall mounting template and Section 1.16. In addition, sufficient space may be required to allow lifting access to the wall mounting plate.

# SECTION 1 - GENERAL

## 1.8 GAS SUPPLY

The local gas supplier should be consulted, at the installation planning stage, in order to establish the availability of an adequate supply of gas. An existing service pipe must NOT be used without prior consultation with the local gas supplier.

The boiler MUST be installed on a gas supply with a governed meter only.

A gas meter can only be connected by the local gas supplier or by a Gas Safe Registered Engineer. In IE by a Registered Gas Installer (RGI).

An existing meter should be checked, preferably by the gas supplier, to ensure that the meter is adequate to deal with the rate of gas supply required.

It is the responsibility of the Gas Installer to size the gas installation pipework in accordance with BS6891:2005. Whilst the principle of the 1:1 gas valve ensures the Logic + range is able to deliver its full output at inlet pressures as low as 14mb, other gas appliances in the property may not be as tolerant. When operating pressures are found to be below the minimum meter outlet of 19mb these should be checked to ensure this is adequate for correct and safe operation.

Allowing for the acceptable pressure loss of 1mb across the installation pipework, it can be assumed that a minimum permitted operating pressure of 18mb will be delivered to the inlet of the appliance. (Reference BS 6400-1 Clause 6.2 Pressure Absorption).

The external gas cock could further reduce the operating pressure when measured at its test point. The pressure drop is relative to the heat input to the boiler (kW), refer to graph below.

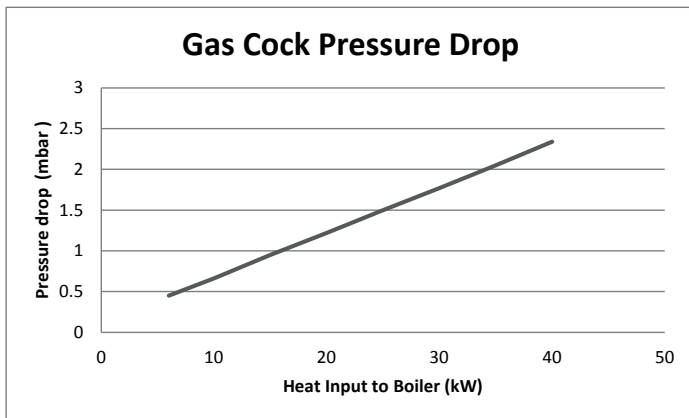

### IMPORTANT.

Ensure all gas valve connections are gas tight with a gas soundness check up to the gas control valve.

Installation pipes must be fitted in accordance with BS.6891. In IE refer to IS.813:2002.

The complete installation MUST be tested for gas tightness and purged as described in the above code.

## 1.9 FLUE INSTALLATION

Plumbing will occur at the terminal so terminal positions where this could cause a nuisance should be avoided.

The flue must be installed in accordance with the recommendations of BS. 5440-1: 2008.

In IE refer to I.S. 813:2002.

The following notes are intended for general guidance:

1. The boiler MUST be installed so that the terminal is exposed to external air.
2. It is important that the position of the terminal allows the free passage of air across it at all times.
3. Minimum acceptable spacing from the terminal to obstructions and ventilation openings are specified in Table 3.

4. Where the lowest part of the terminal is fitted less than 2m (6'6") above a balcony, above ground or above a flat roof to which people have access then the terminal MUST be protected by a purpose designed guard.

Terminal guards are available from boiler suppliers. (Ask for TFC flue guard model no. K6 - round, plastic coated). In case of difficulty contact:

TFC Group Ltd. Tel. + 44 (0) 01732 351 680  
Tower House, Vale Rise Fax. + 44 (0) 01732 354 445  
Tonbridge. Kent TN9 1TB www.tfc-group.co.uk

Ensure that the guard is fitted centrally.

5. The flue assembly shall be so placed or shielded as to prevent ignition or damage to any part of any building.
6. The air inlet/products outlet duct and the terminal of the boiler MUST NOT be closer than 25mm (1") to combustible material. Detailed recommendations on the protection of combustible material are given in BS. 5440-1:2008.

**IMPORTANT.** It is essential to ensure, in practice, that products of combustion discharging from the terminal cannot re-enter the building or buildings through any openings into the building such as ventilators, windows, doors, or other sources of natural air infiltration, such as forced ventilation openings etc.

If products of combustion re-entry is identified or suspected this should be immediately investigated and corrected following the guidance provided in the current Gas Industry Unsafe Situation Procedure.

Table 3 - Balanced Flue Terminal Position

Flue Terminal Positions	Min. Spacing*
1. Directly below, above or alongside an opening window, air vent or other ventilation opening.	300mm
2. Below guttering, drain pipes or soil pipes. <i>BS5440-1 2008</i>	25mm* 75mm
3. Below eaves. <i>BS5440-1 2008</i>	25mm* 200mm
4. Below balconies or a car port roof. <i>BS5440-1 2008</i>	25mm* 200mm
5. From vertical drain pipes or soil pipes. <i>BS5440-1 2008</i>	25mm* 150mm
6. From an internal or external corner or to a boundary alongside the terminal. <i>BS5440-1 2008</i>	25mm* 300mm
7. Above adjacent ground, roof or balcony level.	300mm
8. From a surface or a boundary facing the terminal.	600mm
9. From a terminal facing a terminal.	1,200mm
10. From an opening in a car port (e.g. door or window) into dwelling.	1,200mm
11. Vertically from a terminal on the same wall.	1,500mm
12. Horizontally from a terminal on the wall.	300mm
<b>Vertical Terminals</b>	
13. Above the roof pitch with roof slope of all angles. Above flat roof.	300mm 300mm
14. From a single wall face. From corner walls.	300mm 300mm
15. Below velux window	2000mm
16. Above or side of velux window	600mm

\* Only one reduction down to 25mm is allowable per installation otherwise BS5440-1 2008 dimensions must be followed.

# SECTION 1 - GENERAL

## 1.10 TERMINAL

The terminal assembly can be adapted to accommodate various wall thicknesses. Refer to Section 1.16.

## 1.11 AIR SUPPLY

It is NOT necessary to have a purpose-provided air vent in the room or internal space in which the boiler is installed. Neither is it necessary to ventilate a cupboard or compartment in which the boiler is installed, due to the low surface temperatures of the boiler casing during operation; therefore the requirements of BS 6798, Clause 12, and BS 5440:2 may be disregarded.

## 1.12 WATER CIRCULATION SYSTEM

### IMPORTANT.

A minimum length of 1 metre of copper pipe MUST be fitted to both flow and return connections from the boiler before connection to any plastic piping.

The central heating system should be in accordance with BS.6798 and, in addition, for smallbore and microbore systems, BS.5449.

### Heat Exchanger Pressure Loss

Boiler Size	12	15	18	24	30
Boiler Output kW	12	15	18	24.2	30.3
Water l/min	8.6	10.7	13	17.2	21.5
Temp °C	20	20	20	20	20
Pressure M.Wg	0.5	0.7	1.0	1.6	2.4

**WATER TREATMENT - see Section 1.22**

## 1.13 BOILER CONTROL INTERLOCKS

Central heating systems controls should be installed to ensure the boiler is switched off when there is no demand for heating, in compliance with Building Regulations.

Heating systems utilising full thermostatic radiator valve control of temperature in individual rooms should also be fitted with a room thermostat controlling the temperature in a space served by radiators not fitted with such a valve.

When thermostatic radiator valves are used, the space heating temperature control over a living / dining area or hallway having a heating requirement of at least 10% of the minimum boiler heat output should be achieved using a room thermostat, whilst other rooms are individually controlled by thermostatic radiator valves. However, if the system employs thermostatic radiator valves on all radiators, or two port valves, then a bypass circuit must be fitted with an automatic bypass valve to ensure a flow of water should all valves be in the closed position.

## 1.14 ELECTRICAL SUPPLY

### WARNING.

This appliance must be earthed.

Wiring external to the appliance MUST be in accordance with the current I.E.E. (BS.7671) Wiring Regulations and any local regulations which apply. For IE reference should be made to the current ETCI rules for electrical installations.

The mains supply to the boiler and system wiring centre shall be through one common fused double pole isolator. For new heating systems, and where practicable replacement boiler installation, the isolator shall be situated adjacent to the appliance.

**NOTE. THE APPLIANCE MUST BE WIRED WITH A PERMANENT LIVE SUPPLY. THE BOILER WARRANTY WILL BE INVALID IF THIS REQUIREMENT IS NOT COMPLIED WITH.**

## 1.15 CONDENSATE DRAIN

### Refer to Section 2.19

A condensate drain is provided on the boiler. This drain must be connected to a drainage point on site. All pipework and fittings in the condensate drainage system MUST be made of plastic - *no other materials may be used.*

### IMPORTANT.

Any external runs must be in accordance with BS 6798.

The drain outlet on the boiler is sized for standard 21.5mm overflow pipe. It is a universal fitting to allow use of different brands of pipework.

# SECTION 1 - GENERAL

## 1.16 BOILER DIMENSIONS, SERVICES & CLEARANCES

all dimensions in mm

The boiler connections are made on the boiler connection tails. Refer to Section 2.20.

The following minimum clearances must be maintained for operation and servicing.

Additional space will be required for installation, depending upon site conditions.

### Side and Rear Flue

- a. Provided that the flue hole is cut accurately, e.g. with a core drill, the flue can be installed from inside the building where

wall thicknesses do not exceed 600mm. Where the space into which the boiler is going to be installed is less than the length of flue required the flue must be fitted from the outside.

### Installation from inside ONLY

- b. If a core boring tool is to be used inside the building the space in which the boiler is to be installed must be at least wide enough to accommodate the tool.

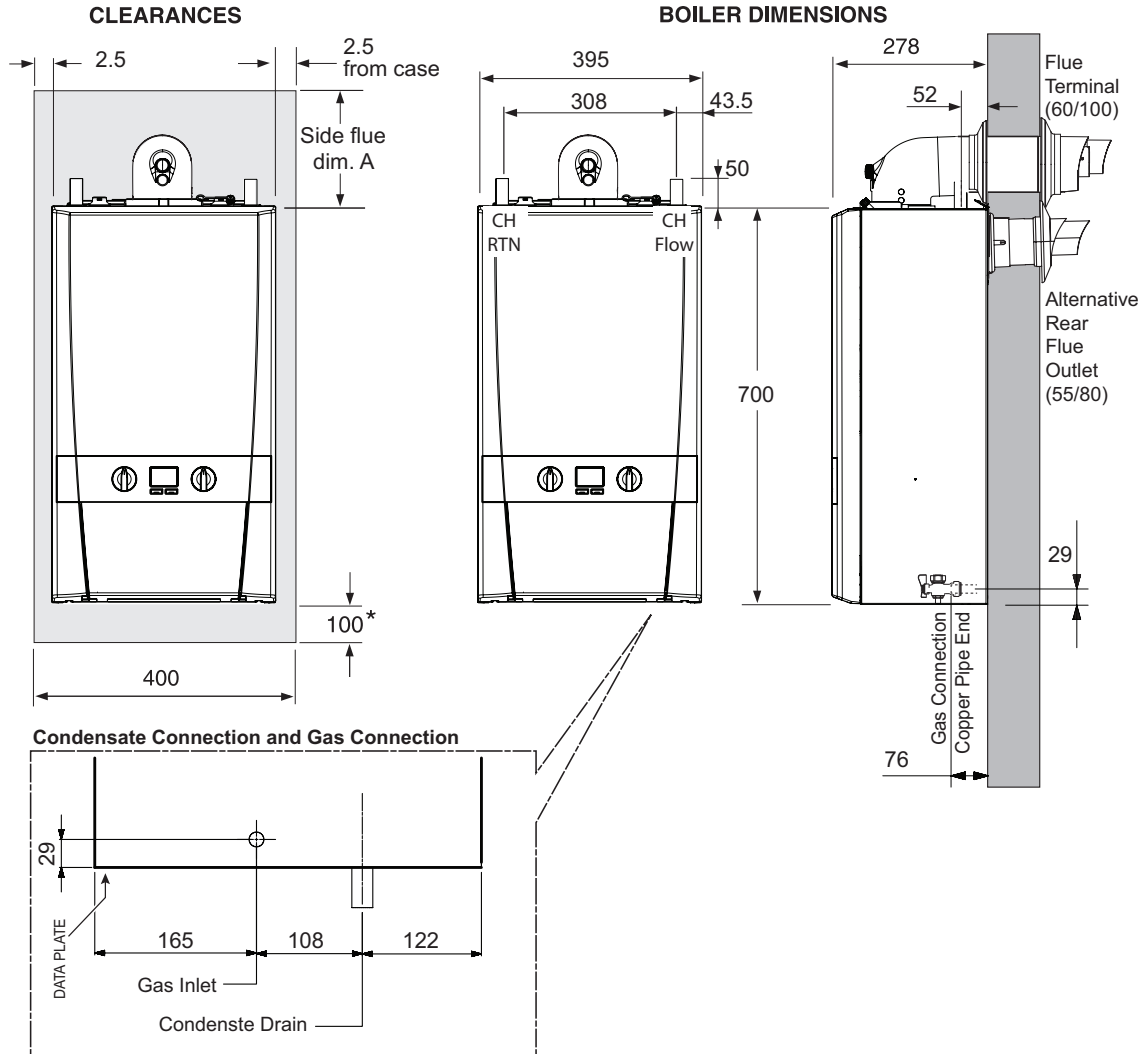

### Min Top Clearance "A" 165mm Rear flue type

Min Top Clearance "A" SIDE Flue type	(167)	(193)	(219)	(245)	(271)	(297)	(323)	(349)	(375)	(401)	mm
Distance from Horizontal (mm) required to achieve 1.5deg fall to the appliance	26	52	78	104	130	156	182	208	234	305	

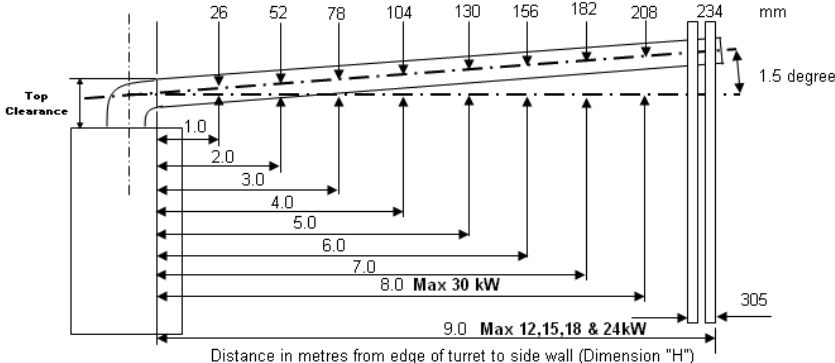

1. Dimension "H" must remain inside the Maximum flue length requirement for the designated kW capacity of the appliance been installed.
2. For flue lengths requiring "D" pack extensions the flue must incline by 26mm per 1 Metre of flue length. No flue length greater than the maximum flue length shown above should be exceeded.

### Front clearance

The minimum front clearance when built in to a cupboard is 5mm from the cupboard door but 450mm overall clearance is still required, with the cupboard door open, to allow for servicing.

### \* Bottom clearance

Bottom clearance after installation can be reduced to 5mm.

This must be obtained with an easily removable panel to provide the 100mm clearance required for servicing.

## SECTION 1 - GENERAL

### 1.17 OPEN VENT SYSTEM REQUIREMENTS

The system should be vented directly off the boiler flow pipe, as close to the boiler as possible. The cold feed entry should be inverted and **MUST** be positioned between the pump and the vent, and not more than 150mm away from the vent connection.

**Note.** Combined feed and vent pipes may also be fitted.

There should be a minimum height 450mm of open vent above the cistern water level. If this is not possible refer to Section 1.19. The vertical distance between the highest point of the system and the feed/expansion cistern water level **MUST** not be less than 450 mm. The pump must be fitted on the flow side of the boiler.

A suitable pump is a domestic circulator capable of providing a maximum 20°C temperature differential across the boiler with the whole of the heating circuit open (e.g. Grundfos UPS 15/50, 15/60 or equivalent). With the minimum flow circuit allowed by the controls the differential must not exceed 25 °C.

The vertical distance between the pump and feed/expansion cistern **MUST** comply with the pump manufacturer's minimum requirements, to avoid cavitation. Should these conditions not apply either lower the pump position or raise the cistern above the minimum requirement specified by **Ideal Boilers**. The isolation valves should be fitted as close to the pump as possible.

It is recommended that an automatic air vent should be fitted to the return connection.

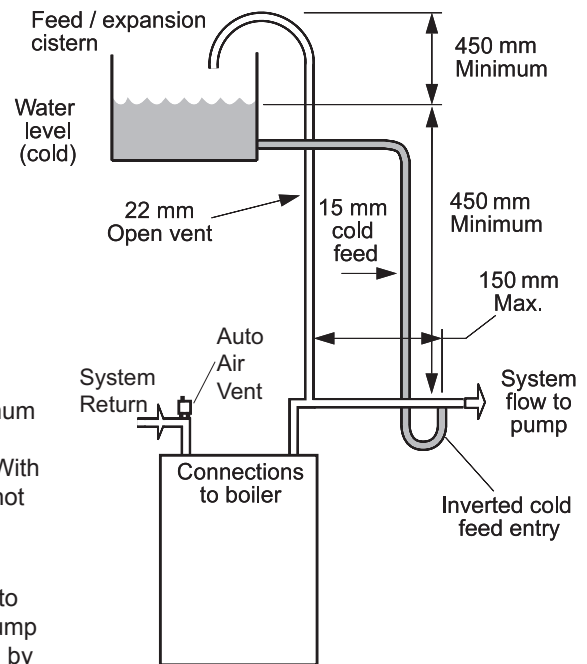

### 1.18 SCHEMATIC PIPEWORK AND SYSTEM BALANCING

The boiler does not normally need a bypass but at least some radiators on the heating circuit, of load at least 10% of the minimum boiler output, must be provided with twin lockshield valves so that this minimum heating load is always available, refer to Sections 1.13 & 1.21.

#### Balancing

1. Set the programmer to ON for both CH and HW. Turn the cylinder thermostat down. Close the manual or thermostatic valves on all radiators, leaving the twin lockshield valves (on the radiators referred to above) in the open position. Turn up the room thermostat and adjust these lockshield valves to give boiler flow and return temperatures not more than 20°C apart. These valves should now be left as set.
2. Open all manual or thermostatic radiator valves and adjust the lockshield valves on remaining radiators to give around 20°C temperature drop at each radiator.
3. Turn up the cylinder thermostat and adjust the cylinder balancing valve so that the cylinder achieves a maximum flow consistent with adequate flow to the radiators. Check that with only the domestic hot water loop in circuit a differential temperature of 25°C across the boiler is not exceeded.
4. Adjust room and cylinder thermostats and programmer to NORMAL settings.

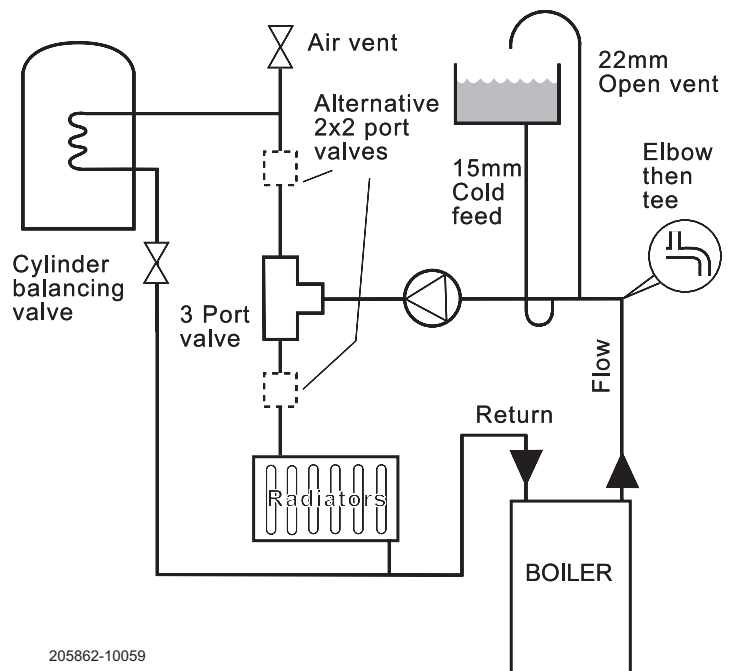

205862-10059

## SECTION 1 - GENERAL

### 1.19 LOW HEAD AND LARGE SYSTEMS WITH EXTENSIVE PIPE RUNS - OPEN VENT

This arrangement is useful for large systems where radiators at the extremities are difficult to vent. This can lead to pumping over with conventional feed and vent arrangements.

The following conditions **MUST** be observed:

1. The top of the automatic air vent must be below the cold water level.
2. The static water level (cold) must be at least 200mm above the top of the horizontal flow pipe, fitted as shown. The vent connection **MUST NOT** be made immediately off the top of the boiler as venting is made less efficient.
3. The maximum practical length of 22mm cold feed pipe should be used in order to reduce the effective volume of hot system water expanding into the feed/expansion cistern to a minimum.

**Note.** The pump manufacturers' minimum requirements must be complied with.

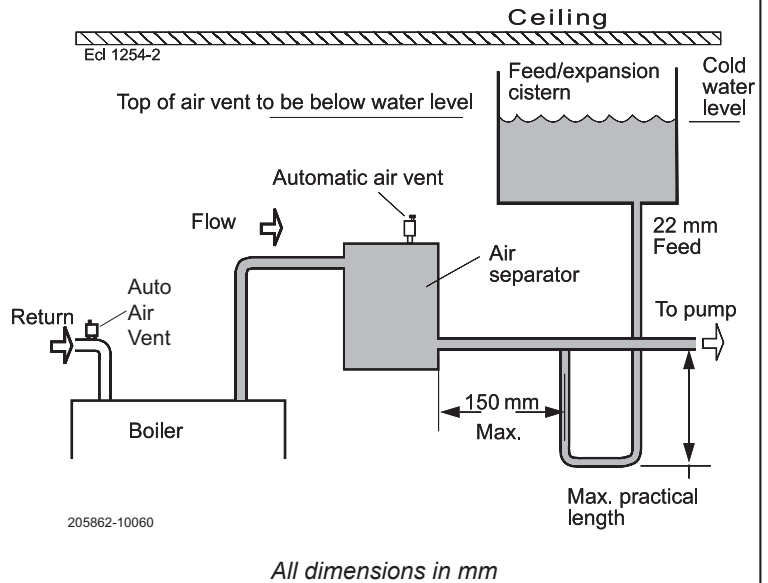

### 1.20 SEALED SYSTEM REQUIREMENTS

#### Notes.

- a. The method of filling, refilling, topping up or flushing sealed primary hot water circuit from the mains via a temporary hose connection is only allowed if acceptable to the local water authority.
- b. When installing the filling device, it must be connected as shown to fully comply with the water regulations. This may involve the fitting of an additional WRAS approval isolator valve to the mains supply.

#### 1. General

- a. The installation must comply with the requirements of BS. 6798 and BS. 5449.
- b. The installation should be designed to work with flow temperatures of up to 80 °C.
- c. All components of the system, including the heat exchanger of the indirect cylinder, must be suitable for a working pressure of 3 bar and a maximum temperature of 110°C. Care should be taken in making all connections so that the risk of leakage is minimised.

#### 2. Safety Valve

A spring loaded safety valve complying with the relevant requirements of BS. 6759 must be fitted in the flow pipe as close to the boiler as possible and with no intervening valve or restriction. The valve should have the following features:

- a. A non-adjustable preset lift pressure not exceeding 3bar.

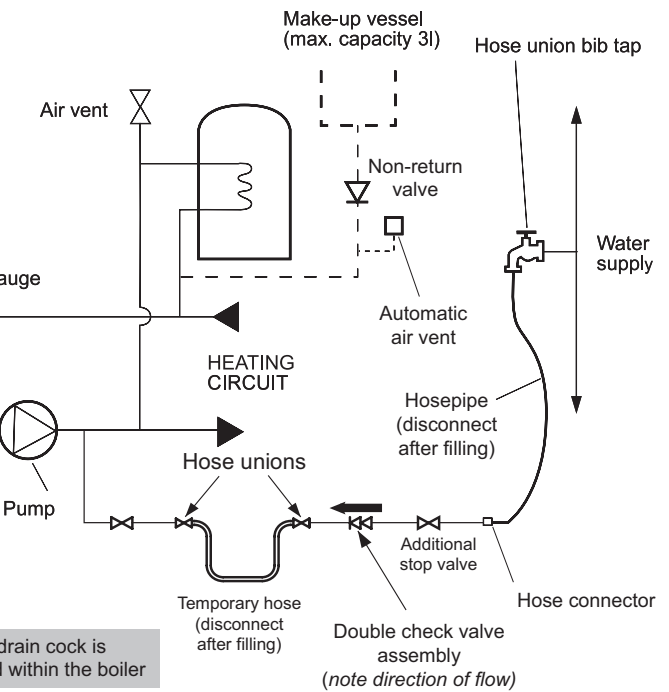

- b. A manual testing device.
- c. Provision for connection of a discharge pipe. The valve or discharge pipe should be positioned so that the discharge of water or steam cannot create a hazard to the occupants of the premises or cause damage to electrical components and wiring.

#### 3. Pressure Gauge

A pressure gauge covering at least the range 0-4 bar must be fitted to the system. The gauge should be easily seen from the filling point and should preferably be connected at the same point as the expansion vessel.

## SEALED SYSTEM REQUIREMENTS - continued

### 4. Expansion Vessel

- a. A diaphragm type expansion vessel must be connected to a point close to the inlet side of the pump, the connecting pipe being not less than 15 mm size and not incorporating valves of any sort.
- b. The vessel capacity must be adequate to accept the expansion of the system water when heated to 110°C.
- c. The charge pressure must not be less than the static water head above the vessel. The pressure attained in the system when heated to 110° C should be at least 0.35 bar less than the lift pressure of the safety valve. For guidance on vessel sizing refer to the table in this section.

For further details refer to BS. 5449, BS. 7074:1 and the British Gas Corporation publication 'Material and Installation Specifications for Domestic Central Heating and Hot Water'. For IE refer to the current edition of I.S.813.

### 5. Cylinder

The cylinder must be either of the indirect coil type or a direct cylinder fitted with an immersion calorifier which is suitable for operating on a gauge pressure of 0.35 bar in excess of the safety valve setting. Single feed indirect cylinders are not suitable for sealed systems.

### 6. Make-up Water

Provision must be made for replacing water loss from the system, either:

- a. From a manually filled make-up vessel with a readily visible water level. The vessel should be mounted at least 150 mm above the highest point of the system, and be connected through a non-return valve to the system, fitted at least 300 mm below the make-up vessel on the return side of the domestic hot water cylinder or radiators.  
or
- b. Where access to a make-up vessel would be difficult by pre-pressurisation of the system. Refer to 'Filling', below.

### 7. Mains Connection

There must be no direct connection to the mains water supply or to the water storage tank supplying domestic water, even through a non-return valve, without the approval of the local water authority.

### 8. Filling

The system may be filled by one of the following methods:

- a. Through a cistern, used for no other purposes, via a ball valve permanently connected directly to a service pipe and/or a cold water distributing pipe.  
The static head available from the cistern should be adequate to provide the desired initial system design pressure. The cold feed pipe from the cistern should include a non-return valve and a stop valve with an automatic air vent connected between them, the stop valve being located between the system and the

automatic air vent. The stop valve may remain open during normal operation of the system if automatic water make-up is required.

- b. Through a self-contained unit comprising a cistern, pressure booster pump (if required) and, if necessary, an automatic pressure reducing valve and flow restrictor. The cistern should be supplied through a temporary connection from a service pipe or cold water distributing pipe.  
This unit may remain permanently connected to the heating system to provide limited automatic water make-up. Where the temporary connection is supplied from a service pipe or distributing pipe which also supplies other draw-off points at a lower level then a double check valve shall be installed upstream of the draw-off point.
- c. Through a temporary hose connection from a draw-off tap supplied from a service pipe under mains pressure. Where the mains pressure is excessive a pressure reducing valve shall be used to facilitate filling.

The following fittings shall form a permanent part of the system and shall be fitted in the order stated:

A stop valve complying with the requirements of BS. 1010, Part 2 (the hose from the draw-off tap shall be connected to this fitting).

A test cock.

A double check valve of an approved type.

- Thoroughly flush out the whole of the system with cold water, without the pump in position.
- With the pump fitted, fill and vent the system until the pressure gauge registers 1.5 bar. Examine for leaks.
- Check the operation of the safety valve by manually raising the water pressure until the valve lifts. This should occur within  $\pm 0.3$  bar of the preset lift pressure.
- Release water from the system until the initial system design pressure is reached.
- Light the boiler and heat the system to the maximum working temperature. Examine for leaks.
- Turn off the boiler and drain the system while still hot.
- Refill and vent the system.
- Adjust the initial pressure to the required value.

**Sizing procedure for expansion vessels:** The volume of the expansion vessel (litres) fitted to a sealed system shall not be less than that given by the table on the following page, multiplied by a factor of 0.8 (for flow temperatures of less than 83°C).

*continued . . . . .*

## SECTION 1 - GENERAL

<b>SEALED SYSTEM REQUIREMENTS - continued</b>								
<b>Safety valve setting</b>	<b>3.0 bar</b>			<b>2.5 bar</b>			<b>2.0 bar</b>	
<b>Vessel charge and initial system pressure</b>	0.5 bar	1.0 bar	1.5 bar	0.5 bar	1.0 bar	1.5 bar	0.5 bar	1.0 bar
<b>Total water content of system litres</b>	<b>Expansion vessel volume litres</b>							
<b>25</b>	2.1	2.7	3.9	2.3	3.3	5.9	2.8	5.0
<b>50</b>	4.2	5.4	7.8	4.7	6.7	11.8	5.6	10.0
<b>75</b>	6.3	8.2	11.7	7.0	10.0	17.7	8.4	15.0
<b>100</b>	8.3	10.9	15.6	9.4	13.4	23.7	11.3	20.0
<b>125</b>	10.4	13.6	19.5	11.7	16.7	29.6	14.1	25.0
<b>150</b>	12.5	16.3	23.4	14.1	20.1	35.5	16.9	30.0
<b>175</b>	14.6	19.1	27.3	16.4	23.4	41.4	19.7	35.0
<b>200</b>	16.7	21.8	31.2	18.8	26.8	47.4	22.6	40.0
<b>225</b>	18.7	24.5	35.1	21.1	30.1	53.3	25.4	45.0
<b>250</b>	20.8	27.2	39.0	23.5	33.5	59.2	28.2	50.0
<b>275</b>	22.9	30.0	42.9	25.8	36.8	65.1	31.0	55.0
<b>300</b>	25.0	32.7	46.8	28.2	40.2	71.1	33.9	60.0
<b>Multiplying factors for other system volumes</b>	0.0833	0.109	0.156	0.094	0.134	0.237	0.113	0.20

### 1.21 SYSTEM BALANCING

The boiler does not normally need a bypass but at least some radiators on the heating circuit, of load of at least 10% of the minimum boiler output, must be provided with twin lockshield valves so that this minimum heating load is always available. See note regarding thermostatic radiator valves on page 13 and 15.

**Note.** *Systems incorporating zone valves which could completely cut off the flow through the system must also include a bypass.*

#### BALANCING

1. Set the programmer to ON.  
Close the manual or thermostatic valves on all radiators, leaving the twin lockshield valves (on the radiators referred to above) in the OPEN position.  
Turn up the room thermostat and adjust the lockshield valve to give an uninterrupted flow through the radiator.  
These valves should now be left as set.
2. Open all manual or thermostatic radiator valves and adjust the lockshield valves on the remaining radiators, to give around 20°C temperature drop at each radiator.

3. Adjust the room thermostat and programmer to NORMAL settings.

### 1.22 WATER TREATMENT

#### CENTRAL HEATING

The Logic + Heat H range of boilers have an ALUMINIUM alloy heat exchanger.

#### IMPORTANT.

**The application of any other treatment to this product may render the guarantee of Ideal Boilers Invalid.**

**Ideal Boilers** recommend Water Treatment in accordance with the Benchmark Guidance Notes on Water Treatment in Central Heating Systems.

If water treatment is used **Ideal Boilers** recommend only the use of SCALEMASTER SM-1 PRO, FERNOX, MB-1, ADEY MC1, SENTINEL-X100, CALMAG CM100 inhibitors and associated water treatment products, which must be used in accordance with the manufacturers' instructions.

#### Notes.

1. *It is most important that the correct concentration of the water treatment products is maintained in accordance with the manufacturers' instructions.*
2. *If the boiler is installed in an existing system any unsuitable additives MUST be removed by thorough cleansing. BS 7593:2006 details the steps necessary to clean a domestic heating system.*
3. *In hard water areas, treatment to prevent lime scale may be necessary - however the use of artificially softened water is NOT permitted.*
4. *Under no circumstances should the boiler be fired before the system has been thoroughly flushed.*

For further information contact:

Fernox Cookson Electronics  
Forsyth Road, Sheerwater, Woking  
Surrey GU21 5RZ  
+44 (0) 870 601 5000

Sentinel Performance Solutions  
The Heath Business & Technical Park  
Runcorn, Cheshire WA7 4QX  
Tel: 0800 389 4670  
[www.sentinel-solutions.net](http://www.sentinel-solutions.net)

Scalemaster Water Treatment Products  
Emerald Way, Stone, Staffordshire  
ST15 0SR  
Tel: 01785 811636

Calmag Ltd.  
Unit 3-6, Crown Works  
Bradford Road, Sandbeds, Keighley  
West Yorkshire BD20 5LN  
Tel: +44 (0) 1535 210 320

Adey Professional Heating Solutions  
Gloucester Road,  
Cheltenham GL51 8NR  
Tel: +44 (0) 1242 546700

## SECTION 2 - INSTALLATION

### 2.1 BOILER ASSEMBLY - Exploded View

Note that item numbers are linked to the spares list

- |     |                        |     |                                     |     |                                      |
|-----|------------------------|-----|-------------------------------------|-----|--------------------------------------|
| 103 | HEAT EXCHANGER DRAIN   | 224 | FLUE MANIFOLD TOP                   | 308 | IGNITOR UNIT                         |
| 106 | PIPE - RETURN          | 225 | FLUE MANIFOLD - TOP SEALING CAP     | 313 | IGNITION LEAD                        |
| 107 | FLOW MANIFOLD/ASSEMBLY | 226 | FLUE MANIFOLD - REAR SEALING CAP    | 320 | HARNESS DETECTION LEAD               |
| 203 | GAS COCK               | 227 | CLAMP RETAINING FLUE TURRET         | 324 | CONTROLS BOX LID                     |
| 204 | PIPE - GAS INLET       | 228 | HOSE CONDENSATE INTERNAL            | 325 | CONTROL BOX FRONT                    |
| 205 | GAS VALVE              | 229 | SIPHON TRAP                         | 401 | HEAT ENGINE                          |
| 206 | PIPE - GAS INJECTOR    | 231 | CONDENSATE OUTLET CONNECTION        | 404 | ELBOW RETURN CONNECTOR               |
| 211 | INJECTOR ASSEMBLY      | 233 | FLUE SENSING NIPPLE                 | 503 | WALL MOUNTING & FLOW SUPPORT BRACKET |
| 214 | VENTURI                | 301 | CONTROLS BOX HINGES & HARNESS CLIPS | 504 | FRONT PANEL                          |
| 215 | FAN                    | 302 | PCB                                 | 505 | FASCIA                               |
| 217 | BURNER                 | 304 | CONTROL THERMISTOR (RETURN)         | 506 | BRACKET - GAS VALVE                  |
| 218 | GASKET - BURNER        | 305 | POTENTIOMETER & BLANK KNOBS         | 512 | INFILL FRONT PANEL                   |
| 219 | SUMP CLEAN OUT COVER   | 306 | ELECTRODE IGNITION                  |     |                                      |
| 223 | FLUE MANIFOLD          | 307 | ELECTRODE DETECTION                 |     |                                      |

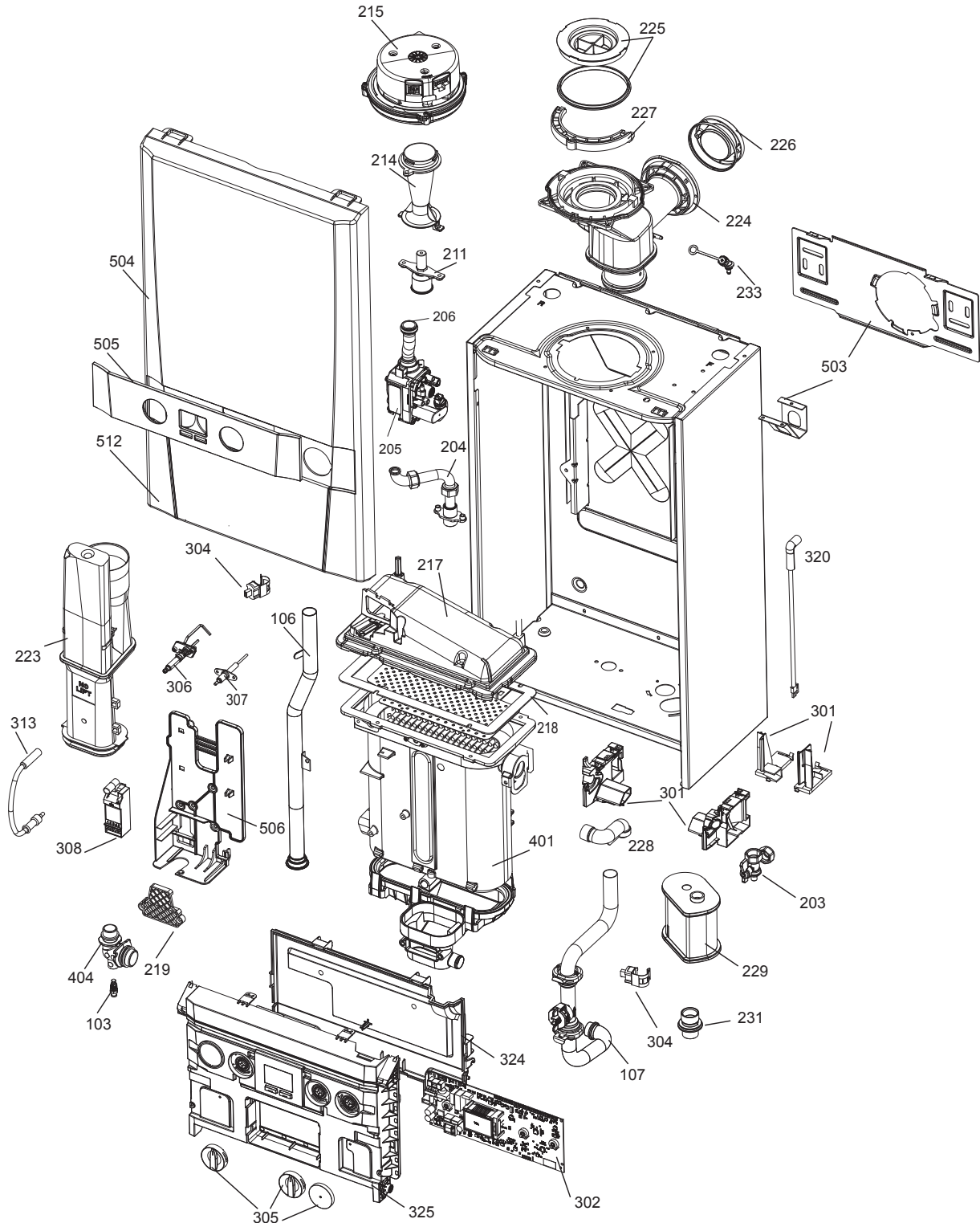

## SECTION 2 - INSTALLATION

### 2.2 UNPACKING

The boiler is supplied fully assembled in Pack A. A telescopic or non-telescopic flue assembly for rear or side flue outlet in Pack B is supplied as a separate order.

Unpack and check the contents.

#### Pack A Contents

- A Boiler
- B Hardware Pack
- C Wall Mounting Plate
- D These Installation/Users Instructions
- E Wall Mounting Template (located on internal protective packaging)
- F Boiler Guarantee & Registration Pack

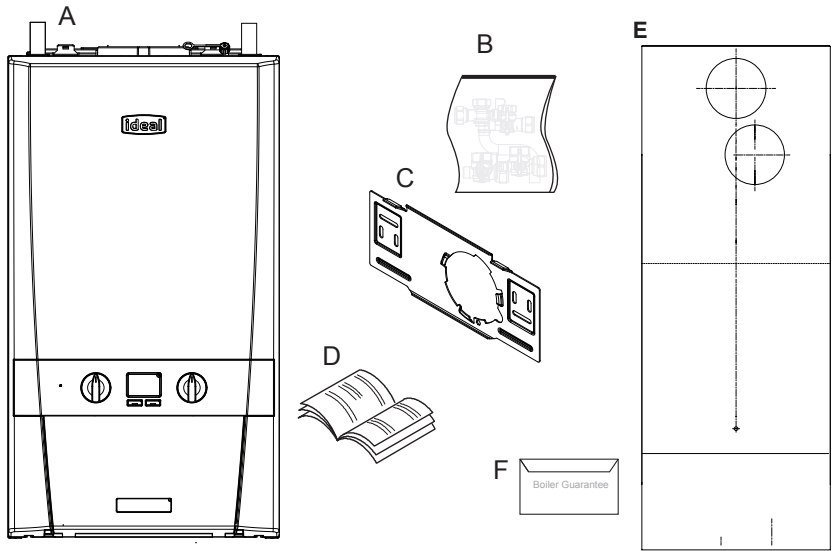

#### HARDWARE PACK CONTENTS

##### Gas Valve Pack

- 1. Washer - Gas (blue)
- 2. Gas Cock

##### Accessory Pack

- 1. Screw (x3)
- 2. Wallplug (x3)

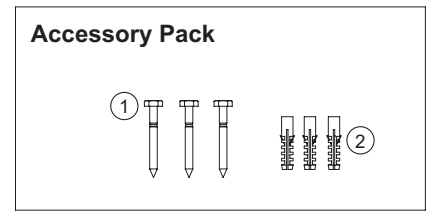
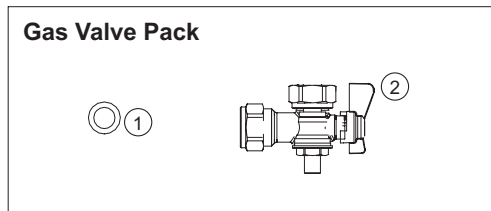

## SECTION 2 - INSTALLATION

### UNPACKING....CONT'D

**Note.** This flue system incorporates a removable flue outlet nose that utilises a push fit location system. This enables the installation of deflector, high level or balcony outlet flue kits without the removal of the whole 'B' pack terminal. The appliance must not be operated without the desired outlet nose correctly fitted in place.

*Note.* Location dimples must be aligned with terminal mounting frame.

#### Pack B Contents Rear Flue Outlet Kit (55/80)

- A Plastic Connector
- B Flue Terminal
- C Rubber terminal wall seal
- D 2 x Self Tapping Screws
- E Sealing Tape
- F Cutting Aid

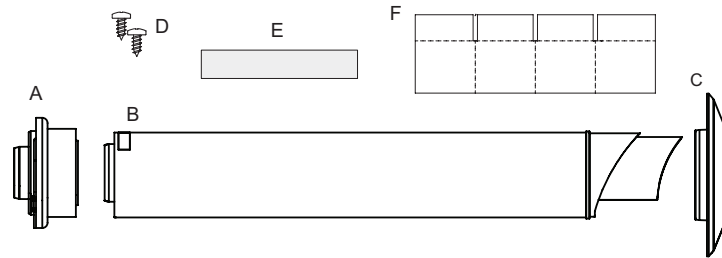

#### Pack B Contents Non-Telescopic (60/100)

- A Flue terminal
- B Flue turret
- C Wall Seal (white)
- D Cutting Aid
- E Wall Seal (black)

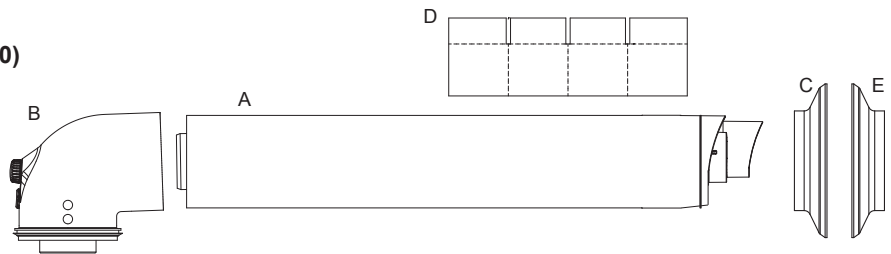

#### Pack B Contents Telescopic (60/100)

- A Telescopic flue terminal
- B Flue turret
- C Wall seal (black)
- D Screw
- E Sealing Tape
- F Wall Seal (White)

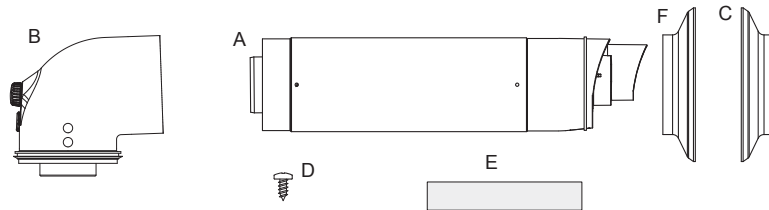

### 2.3 FRONT PANEL REMOVAL

1. Loosen the 2 screws retaining the front panel.
2. Pull the two clips downwards to disengage.
3. Pull the front panel forward and upwards to remove.

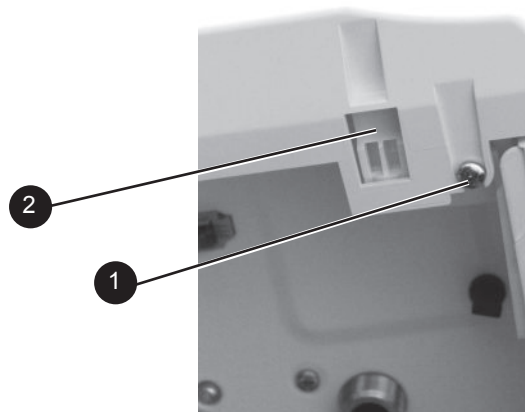

## SECTION 2 - INSTALLATION

### 2.4 WALL MOUNTING TEMPLATE

The wall mounting template is located on the internal protective packaging. The template shows the position of the fixing and rear flue centre holes for a standard installation

*Care MUST be taken to ensure the correct holes are drilled.*

1. Tape template into the required position, ensuring its squareness by hanging a plumbline as shown.
2. If fitting a side flue, extend the flue centreline onto the side by **155mm** on a standard wall fix or **200mm** if using a stand-off bracket.
3. Mark the following on to the wall:
  - a. The selected group of wall mounting screw holes.
  - b. The centre position of the flue duct. Marking both the centre and the circumference of the flue duct.
4. Remove the template plate from the wall.

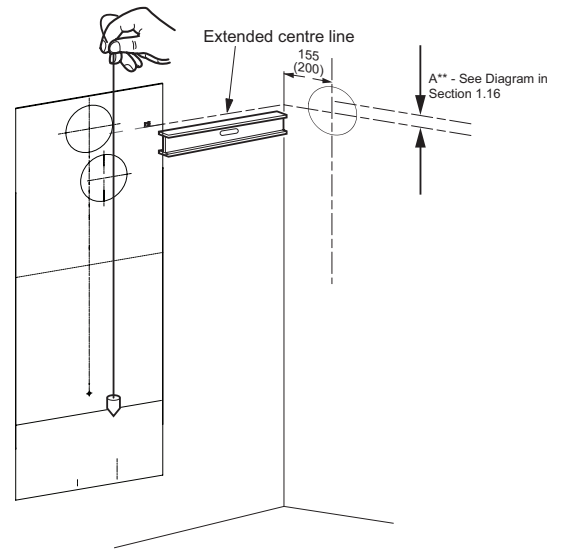

### 2.5 PREPARING THE WALL

#### IMPORTANT.

Ensure that, during the cutting operation, masonry falling outside of the building does not cause damage or personal injury.

1. Cut the rear flue hole (preferably with a 5" core boring tool), ensuring that the hole is square to the wall. Both wall faces immediately around the cut hole should be flat.
2. Drill 3 holes with a 7.5mm / 8mm masonry drill and insert the plastic plugs, provided, for the wall mounting plate and the boiler bottom retaining bracket.
3. Locate 2 No.14 x 50mm screws in the wall mounting plate (one at each side, in any of the 3 holes provided at each side) and screw home.

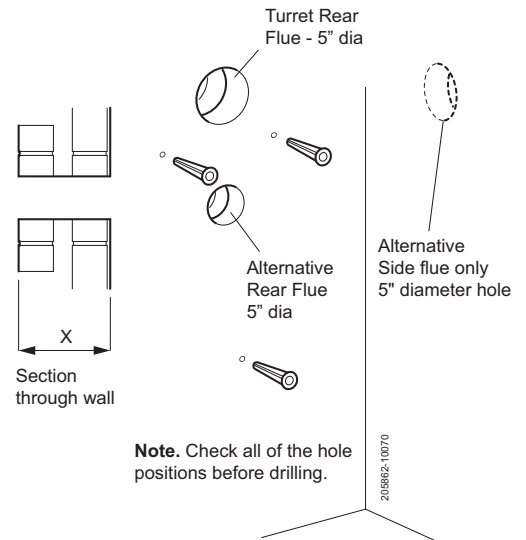

### 2.6 FITTING THE WALL MOUNTING PLATE (TURRET OPTION)

Screw the wall mounting plate to the wall using 2 wall plugs (previously fitted) with the 2 screws provided.

Choose one of the 2 sets of slots in left and right bank. Ensuring that at least one of the screws is fitted into a top slot and the mounting bracket is level.

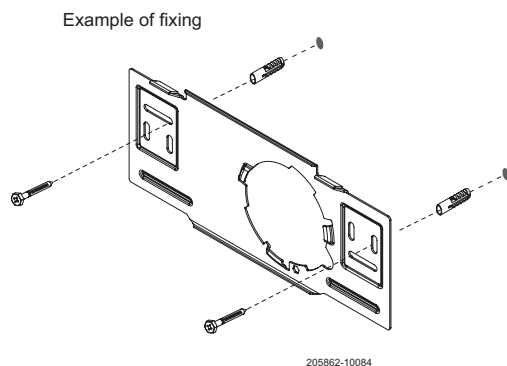

### 2.7 MOUNTING THE BOILER (TURRET OPTION)

1. Remove the top flue plastic blanking disc and retain the plastic horseshoe fixing and screw.
 

*Caution: water may discharge from open pipes*
2. Lift the boiler onto the wall mounting plate (refer to the Introduction section for safe handling advice), locating it over the two tabs.
3. Screw the boiler bottom retaining bracket to the wall with the screw provided.

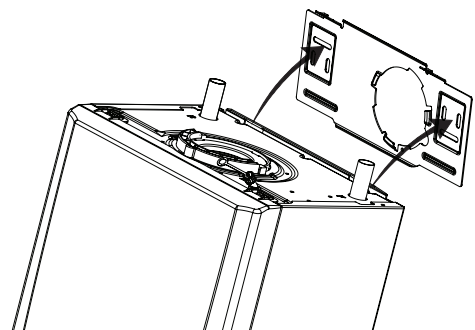

## SECTION 2 - INSTALLATION

### 2.8 DETERMINING THE FLUE LENGTH AND FLUE PACKS REQUIRED

**IMPORTANT.** The boiler must be installed in a vertical position in accordance to the installation instructions.

#### FLUE KITS

**Telescopic Flue 'B' Pack** - contains: Flue turret, telescopic flue incorporating a terminal and rubber wall seals.

**Horizontal Flue Terminal (600mm long) 'B' Pack** - contains: Flue turret, non telescopic single piece flue incorporating a terminal and rubber wall seals.

**Horizontal Flue Terminal (1000mm long) 'B' Pack** - Flue turret, telescopic flue incorporating a terminal, rubber wall seals and instructions.

*Note. If 'B' packs are used on their own (either 1 piece or telescopic), then they MUST be fitted horizontally as the flue inside is designed to slope 1.5 degrees.*

**D Pack Flue Extension 100mm DIA 1000mm long**

**D Pack Flue Extension 100mm DIA 500mm long**

**D Pack Flue Extension 100mm Dia 2000mm long**

**Roof Flue Kit with Vertical Connector**

*When extension 'D' Packs are used the flue duct must incline 1.5 degrees away from the appliance, to allow the condensate to drain back to the boiler and out of the condensate drain. It is recommended that a support bracket is fitted on every 1 metre of*

*pipe work used and the bracket is located as close to the collar as possible. The bracketing must ensure a 1.5 degree fall back to the appliance.*

**Optional Flue Finishing Kit** - & Concentric Flue Screw Retaining Kit (Optional Kit of mechanical fixing of flue joints) Only use water as a lubricant during assembly.

The 'B' pack terminal is classed as part of the maximum flue length.

These flue systems incorporates a removable flue outlet nose that utilises a push fit location system. This enables the installation of deflector, high level or balcony flue kits without the removal of the whole 'B' pack terminal. The appliance must not be operated without the desired outlet nose correctly fitted in place, ensuring the side location dimples are in line with the mounting face allowing the correct sealing of the components.

It is **IMPORTANT** that all attachments are fitted in accordance to the installation instructions provided with them.

The TURRET supplied in the 'B' Pack has an upper combustion sample point with a screw cap seal and a lower air sample point with an air stopper seal. Ensure all caps & seals are in place.

**Additional Termination Kits** available for use with these 'B' packs.

Flue Deflector Kit	The resistance is the equivalent of 1 metre of flue pipe and therefore must be deducted from any maximum flue length
High Level Flue Outlet Kit	The maximum permissible concentric flue length when using a standard (500mm) kit is 4.5 metres
Balcony Flue Outlet Kit	The maximum permissible concentric flue length when using this kit is dependant on the length of the balcony flue outlet run which combined with the concentric run must not exceed the maximum flue length requirement of the appliance it is to be fitted to
Soffit Kit	This kit enables fitment of an external flue below soffits.

**Total Maximum Permissible Horizontal Concentric Flue Length** combining both 'B' Packs and 'D' Packs (Measured from centreline of the turret to the outside of the wall terminal)

12, 15, 18, 24 kW appliances	Total Maximum: 9 metres - minus any flue kit options or bends
30 kW Appliances	Total Maximum: 8 metres - minus any flue kit options or bends

**Total Maximum Permissible Vertical Flue Length** combining both Roof Terminal and 'D' Packs

12, 15, 18, 24, 30 kW Appliances	Total Maximum (60/100): 7.5 Metres - minus any bends
<b>Powered Vertical Flue</b>	
12, 15, 18, 24, 30 kW Appliances	Example: 5 Metres - Concentric Flue and 17m flue pipe only. For additional configurations and details refer to the powered Vertical Instructions

**REAR FLUEING** This is a dedicated flue with no removeable nose section.

**Total Maximum Permissible Rear Flue Length**

12, 15, 18, 24, 30 kW Appliances	Total Maximum (50/80) - 442mm - No additional bends etc allowed		
12, 15, 18, 24, 30 kW Appliances	Total Minimum (50/80) - 115mm - No additional bends etc allowed		
Dedicated High Level Flue Outlet Kit - see kit instruction for further details	(50/80) - Maximum Vertical Run	12 & 30kW - 6 M	15, 18, 24 kW - 11M

## SECTION 2 - INSTALLATION

### DETERMINING THE FLUE LENGTH AND FLUE PACKS REQUIRED.....CONT'D

90° Elbow Kit 60/100 - (Equivalent flue length resistance = 1M)

45° Elbow Kit 60/100 - (Equivalent flue length resistance = 0.6M)

**Minimum Horizontal Flue Lengths** (Centre line of turret to outside of wall terminal)

Telescopic Flue 'B' Pack = 400mm

Horizontal Flue terminal (600mm long) 'B' Pack = 285mm

**Wall Thickness** Std Metric Brick 102.5mm wide

'B' Pack Flue Type 60/100	Minimum permissible Wall Thickness			Maximum permissible Wall Thickness		
	Rear Flue	Rear Flue + Std-Off	Side Flue	Rear Flue	Rear Flue + Std-Off	Side Flue
Horizontal Flue Terminal (600mm long) B Pack	126	102.5	102.5	501	456	456
Telescopic Flue B Pack	231	186	186	429	384	384
Horizontal Flue Terminal (1000mm long) B Pack	546	501	501	761	716	716
Horizontal Flue Terminal (1000mm long) B Pack cut 75mm	471	426	426	686	641	641

\* If wall thickness is <126 and >102.5, contact Ideal Boilers.

**For Flue lengths between 658 & 708 use a Horizontal Flue Terminal (1000mm long) B Pack, cut 75mm off the end of the terminal section of the telescopic flue only.**

### DETERMINING THE FLUE LENGTH AND FLUE PACKS REQUIRED, CONT'D

**FIGURE 1**

Note. Maximum permissible flue length is measured from centre line of appliance's flue outlet to outside wall face.

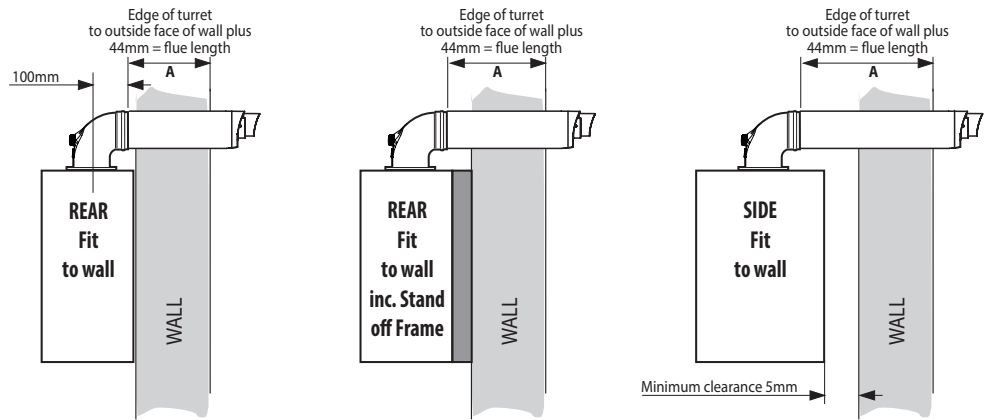

**NOTES**

Centre of turret to edge of turret = 100mm  
 Turret has a flue insertion of 30mm  
 The compressed outer wall seal has protruding wall to seal mounting lip - 14mm  
 From centreline of turret to wall. Rear mount 155mm, side (including clearance) 200mm

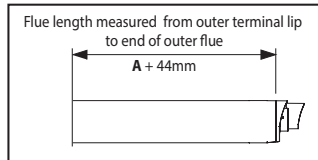

**FIGURE 2**

Shows the flue required when measured from outside edge of turret to the outside face of the wall (to obtain cut length add 44mm)

	Minimum & Maximum finished flue lengths obtainable (dimension 'A' +44mm)							
	Horizontal Flue Terminal (600mm long) B Pack		Telescopic Flue B Pack		Horizontal Flue Terminal (1000mm long) B Pack (Telescopic)		Horizontal Flue Terminal (1000mm long) B Pack (Telescopic) Cut 75mm	
	Minimum	Maximum	Minimum	Maximum	Minimum	Maximum	Minimum	Maximum
<b>B Pack (Standard)</b>	181	556	286	484	601	816	526	741
Plus 1 (1m D pack)	1121	1506	1236	1434	1551	1766	1476	1691
Plus 2 (1m D pack)	2071	2456	2186	2384	2501	2716	2426	2641
Plus 3 (1m D pack)	3021	3406	3136	3334	3451	3666	3376	3591
Plus 4 (1m D pack)	3971	4356	4086	4284	4401	4616	4326	4541
Plus 5 (1m D pack)	4921	5306	5036	5234	5351	5566	5276	5491
Plus 6 (1m D pack)	5871	6256	5986	6184	6301	6516	6226	6441
Plus 7 (1m D pack)	6821	7206	6936	7134	7251	7466	7176	7391
Plus 8 (1m D pack)	7771	8156	7886	8084	8201	8416	8126	8341
Plus 9 (1m D pack)	8721	9000	8836	9000	9000	9000	9000	9000

Max output 30 kW  
Max output 12, 15, 18, 24 kW

Note; Telescopic flue B Pack or attached "D" pack extensions do not need to be cut between minimum and maximum values shown above (except where specified). Horizontal Flue Terminal (600mm long) B Pack flue will require cutting on values below maximum values shown in the table above.

If using the 2000mm D Pack, the maximum usable length per extension is 1950mm

If using the 500mm D Pack, the maximum usable length per extension is 450mm.

### 2.9 CUTTING & SETTING THE FLUE LENGTH

#### TELESCOPIC FLUES

**TELESCOPIC FLUE B PACK** SHOULD ONLY BE ADJUSTED FOR USE WITHIN ITS SPECIFIED RANGE AND MUST NOT BE CUT

**HORIZONTAL FLUE TERMINAL (1000MM LONG) B PACK (TELESCOPIC)** MUST ONLY BE CUT IF REQUIRED FLUE LENGTHS ARE BETWEEN **602 & 652MM**. THIS WILL REQUIRE 75MM TO BE CUT OFF THE TERMINAL END OF THE 1000MM TELESCOPIC FLUE.

ALL OTHER LENGTHS OBTAINED USING "D" PACK EXTENSIONS IN FLUE LENGTH TABLE 1, COLUMN "HORIZONTAL FLUE TERMINAL (1000MM LONG) B PACK CUT 75MM" (TELESCOPIC) SHOULD HAVE THE 75MM CUT OFF THE "D" PACK EXTENSION AND NOT TELESCOPIC FLUE

#### CUT 75MM OFF HORIZONTAL FLUE TERMINAL 1000MM LONG B PACK (TELESCOPIC)

1. Measure cut flue length (A+44mm). (If required telescopic length is not between 658 and 708 then proceed to "Setting Telescopic Flue B Pack").
2. Remove telescopic end piece from the flue body and set aside.
3. Mark the circumference 75mm from the open end of the outer flue.
4. Cut along the 75mm mark cutting **only the outer flue** ensuring the cut is square.
5. Dress the cut end to make sure all burr is removed and the cut edge is in its original shape.
6. Measure 20mm from the newly cut edge of the outer flue, place a mark at the top of the flue approximately 20mm wide & write "stop" on the terminal side of the line.
7. Mark the inner tube 10mm longer than the outer tube around its circumference and cut following the mark to ensure it is cut square
8. Remove all burrs and place a chamfer on the outer edge to aid assembly.
9. Re-assemble telescopic section.

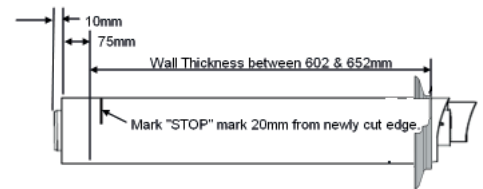

#### SETTING TELESCOPIC FLUE B PACK

1. Measure the required flue length (A+44mm).
2. Measure from the outer terminal lip to end of outer flue. Pull apart flue until desired length is achieved. ENSURE THE STOP MARK IS NOT VISIBLE, IF IT IS, THE FLUE IS TOO SHORT AND SHOULD NOT BE USED.
3. Check that both flue seams are at the top and the outlet terminal is upper most.
4. Drill a 3.5mm hole through one of the 2 outer side holes in the outer flue section into the inserted outer flue (as shown). Take care not to pierce the inner plastic flue. Fit screw provided.
5. Seal the joint on the outer air duct with the tape provided.
6. Fit internal and external wall seals (see installing flue)

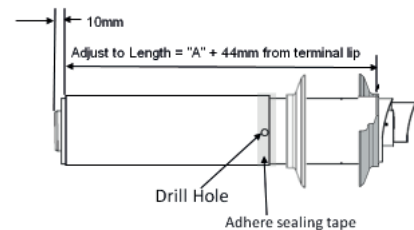

#### CUTTING HORIZONTAL FLUE TERMINAL (600MM LONG) B PACK

1. Measure the required cut flue length (A+44mm). If inside the dimensions shown "1 Piece 600mm" proceed.
2. Measure from the outer terminal lip to end of outer flue. Mark the required cut length (A+44) around the circumference of the outer flue and cut following the mark to ensure it is cut square.
3. Dress the cut end to make sure all burrs are removed and the cut edge is in its original shape.
4. Mark the inner tube 10mm longer than the outer tube around its circumference and cut following the mark to ensure it is cut square.
5. Remove all burrs and place a light chamfer on the outer edge to aid assembly.

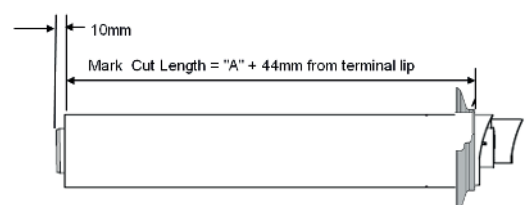

## 2.10 INSTALLING THE FLUE

### FITTING FLUE THROUGH THE WALL

1. Measure wall thickness and add 14mm.
2. Measure from the outer terminal lip towards the end of outer flue, place a small location mark at the dimension acquired at point 1.
3. Add a further 14mm to the dimension, obtain at item 1 (point 1) and place an additional small location mark.
4. Fit external black wall seal ensuring the inside of the outer lip is in contact with the terminal lip you have been measuring from (see fig 1)
5. Fit the internal wall seal approximately 65mm before the outer of the 2 location marks.
6. For an internal fit place flue terminal in the centre of the 5" drilled hole in the wall. Apply pressure and lightly move the flue left to right or up and down. This will cause the outer flange to fold in and allow the flue to pass through the wall.
7. Push through a further 65mm or until the inner flange is pressed against the inner wall. This will allow the outer flange to return to its original shape.
8. Pull back the flue until the first of the 2 location marks is level with the internal face of the wall.

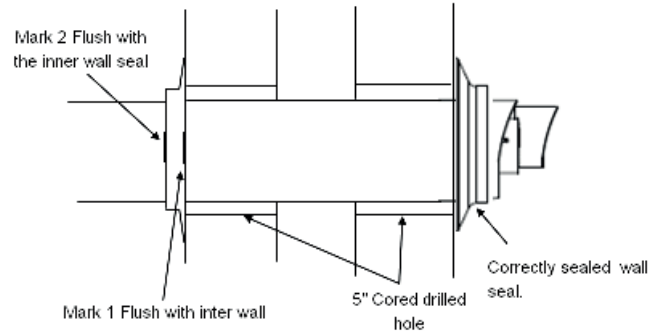
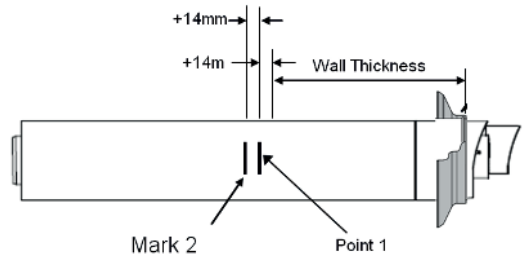

*Note. If the 2 location marks are not visible then the flue is not pulled back far enough to obtain the correct seal. If the 1st location mark has passed the face of the wall the flue has been pulled too far back and the outer wall seal will have been dislodged from its mounting and will need to be refitted.*

9. When 1st mark is in line with the wall, whilst holding the flue firmly, push the white wall sealing flange to the wall until the 2nd of the two marks is just visible. If the last location mark is clearly past the white inner wall seal then the outer wall seal will have been dislodged from its mounting and will need to be re-fitted.

10. Ensure the seam and the outlet terminal are at the top and fitted as shown.

*Note. If less than 50% of the length of the flue is internal the flue should be fitted from outside.*

**Fig 1**

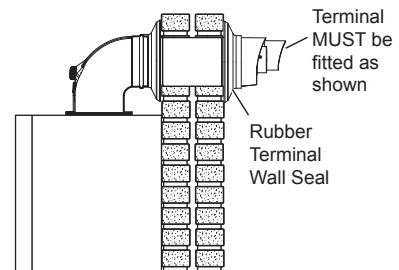
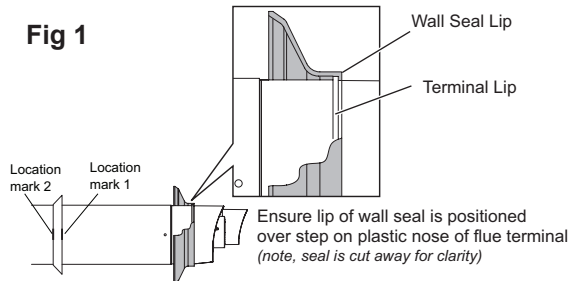

### FITTING THE TURRET - Ensure the condensate trap/siphon is filled with water

1. Ensure the rubber seal is fitted correctly on the appliance manifold and that all flue seals are undamaged.
2. Hold the flue firmly and push the turret on until it has travelled 30mm on to the flue pipe and is fully engaged. Make sure the flue has not rotated or moved forward during fitting and the flue seam is upper most.
3. Push the turret into the manifold ensuring the upper plastic lip is flush with the top of the manifold.
4. Fully engage the clamp location section into the manifold location holes. Rotate down on to turret flange.
5. Secure clamp to appliance using securing screw.
6. Ensure all sample points are accessible and all sample plugs and caps are fitted.

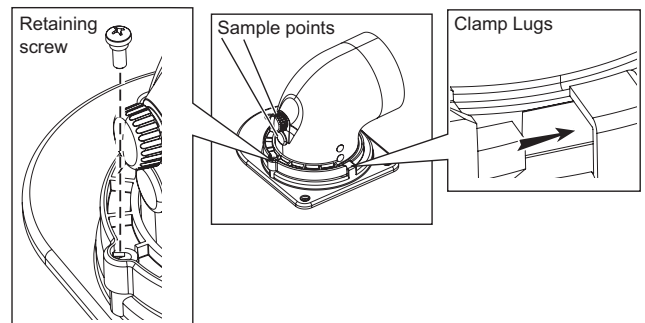
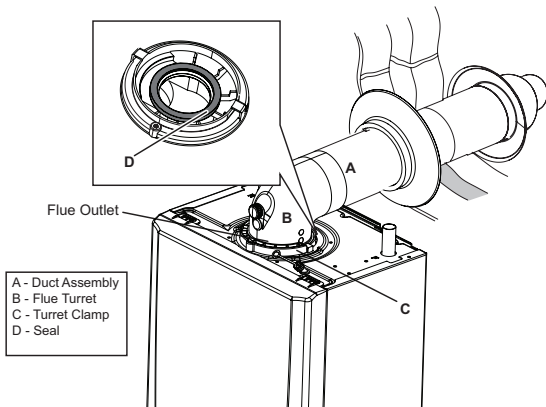

## SECTION 2 - INSTALLATION

### 2.11 REAR FLUE OUTLET KIT (55/80) ASSEMBLY - EXPLODED VIEW

#### LEGEND

1. Duct Assembly
2. Plastic Connector
3. Wall Mounting Plate

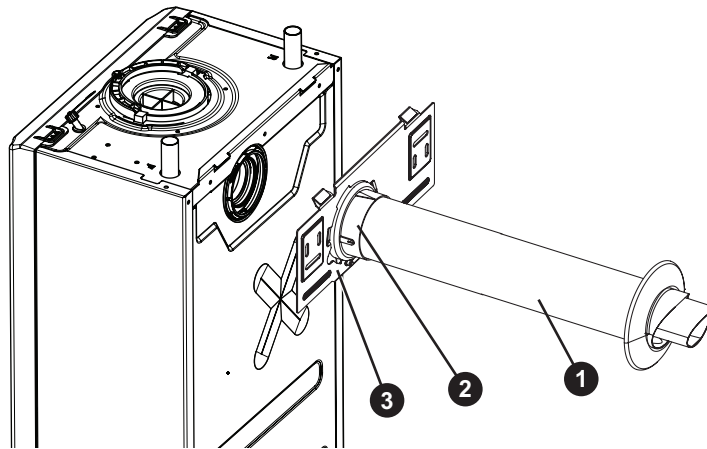

### 2.12 TERMINAL WALL SEAL ASSEMBLY / POSITIONING

Prior to fitting the flue, the rubber terminal wall seal provided in the flue pack **MUST** be fitted to the flue terminal as shown below in Figure 1.

Once the flue is installed it is **IMPORTANT** that the rubber terminal wall seal is pressed against the outside wall to create an adequate seal between the flue and wall as shown in Figure 2.

FIGURE 1

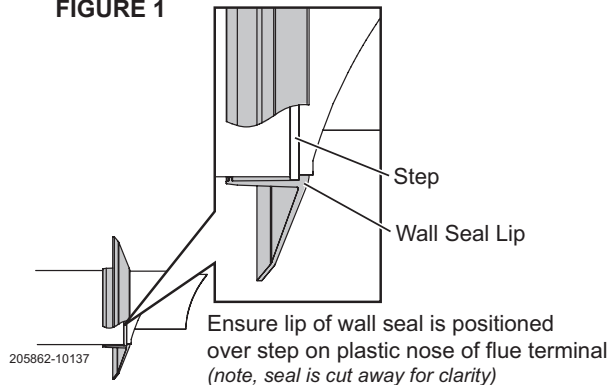
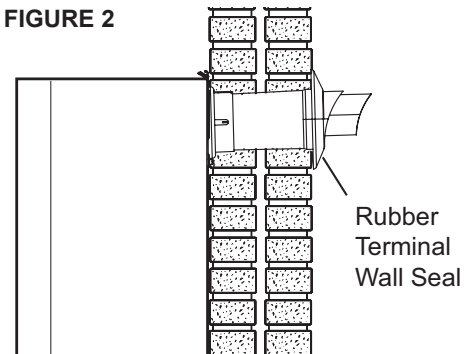
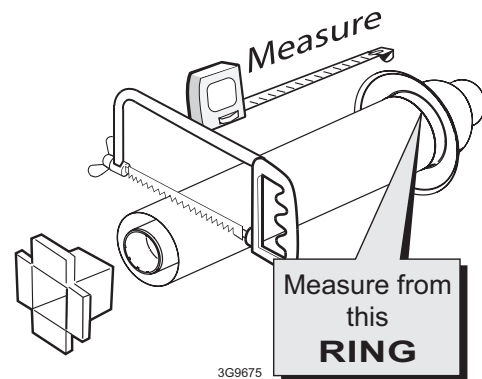
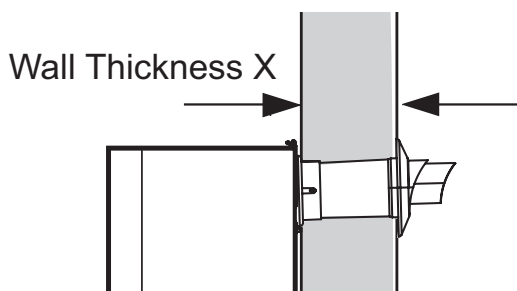

FIGURE 2



### 2.13 SETTING THE REAR FLUE LENGTH - WALL THICKNESS OF 115MM TO 442 MM



1. Measure and note wall thickness X. Refer to Section 1.16.
2. Add 8mm to dimension X and, measuring from the ring, cut the outer tube only.
3. To ensure the tube is cut square, mark the flue all the way around.
4. Cut the inner tube to a length 10mm longer to aid engagement, using the cutting aid provided.

**Note.** If the stand-off frame is used, it is essential to add 45mm to 'X' the measured wall thickness when marking the flue (this will allow for the fitted frame)

## SECTION 2 - INSTALLATION

### 2.14 FITTING THE WALL PLATE / REAR FLUE TERMINAL ASSEMBLY

1. Ensure the rubber terminal wall seal is fitted to the terminal. Refer to Section 2.12.
2. Insert the previously cut to length terminal assembly into the plastic connector.
3. Line up the mark on the top of the plastic connector with the top of the terminal (marked with a label).
4. Drill 2 - 3.5mm dia holes through each side of the plastic connector and the air duct and fit the two self tapping screws (provided) to retain the duct terminal assembly to the plastic connector.
5. Seal the joint between the plastic connector and the terminal air duct with the tape provided.
6. Push the terminal assembly through the prepared hole in the wall until the rubber seal clears the outside wall. Rest the assembly in the hole while fitting the wall mounting plate.
7. Screw the wall mounting plate to the wall using 2 wall plugs (previously fitted) with the 2 screws provided. Choose one of the 2 sets of slots in the left and right bank. Ensure that at least one of the screws is fitted into a top slot.
8. Pull the flue assembly back through the wall mounting plate to seal against the outside wall face and ensure the 3 locating tabs are pulled through the wall mounting plate slots.
9. Turn the plastic connector clockwise to lock the connector into the wall plate.
10. Retain with the M5 screws provided.

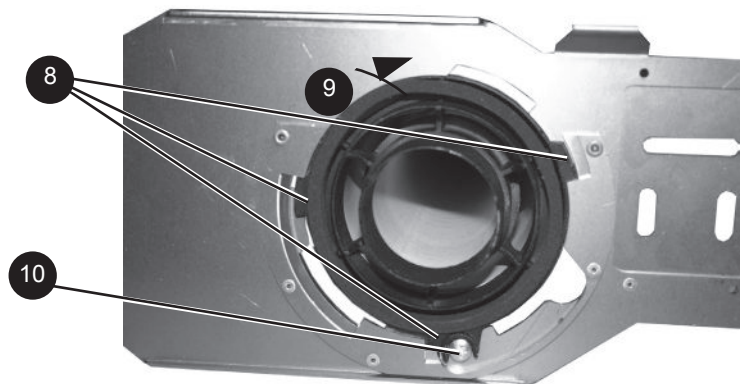
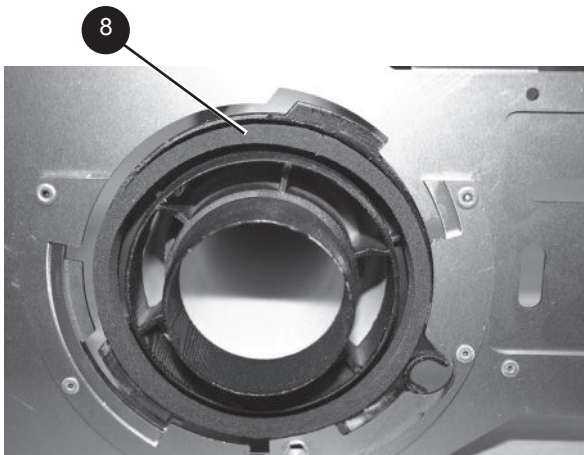
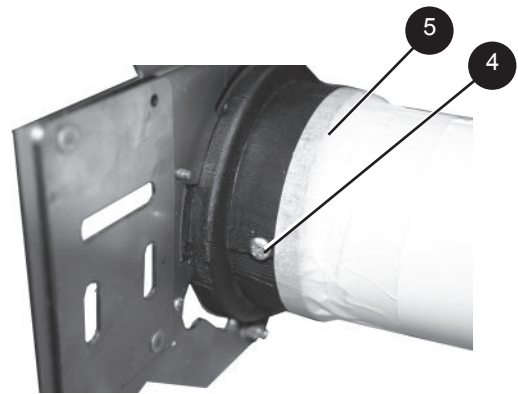
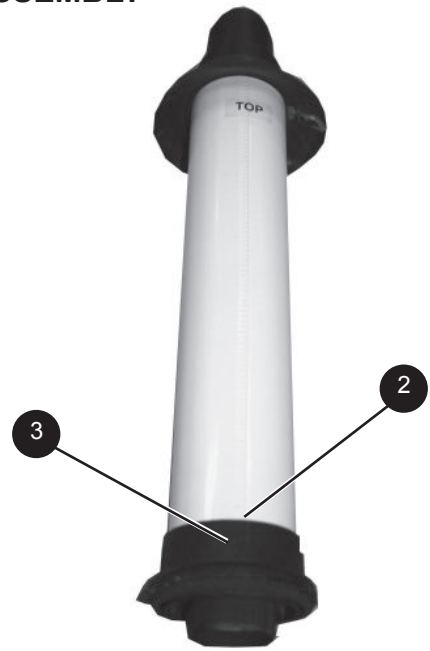

## SECTION 2 - INSTALLATION

### 2.15 MOUNTING THE BOILER - REAR FLUE OUTLET KIT (55/80)

1. Remove the rear flue blanking disk.
2. Lift the boiler onto the wall plate, (refer to the introduction section for safe handling advice), ensuring the boiler is offered to the bracket tabs at an angle as shown below, and carefully allow the boiler to swing down to the wall as this movement engages the rear flue air and flue seal.
3. Screw the boiler bottom retaining bracket to the wall with the screw provided.
4. Remove the top flue blanking disk. Fill the condensate trap within the boiler by pouring a cupful of water into the flue outlet. Take care to ensure that the water is only poured into the flue outlet, and does not spill into the boiler casing.
5. Replace the top flue blanking disc and retain with the horseshoe bracket and fixing screw previously removed.

During assembly check that the flue seals do not become dislodged.

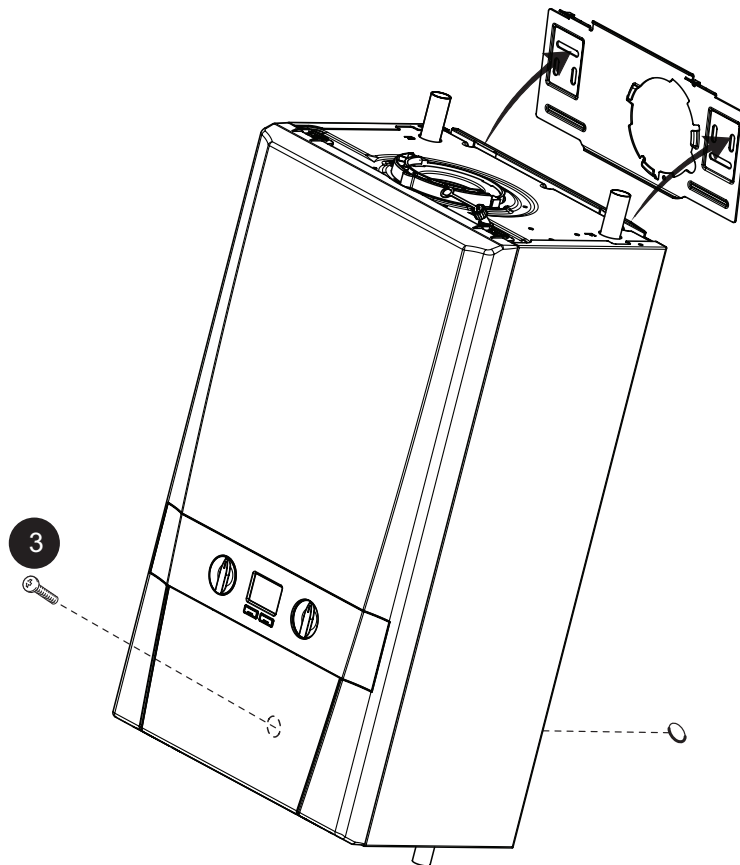
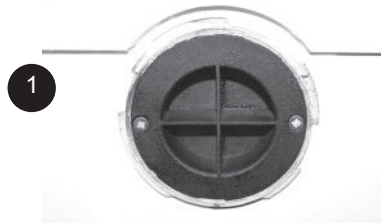

## SECTION 2 - INSTALLATION

### 2.16 FITTING THE OPTIONAL ROOF FLUE KIT (Flat or Pitched)

#### Note.

A flat or pitched roof flashing plate (not supplied) is required before proceeding with the installation of this kit.

This kit is suitable for both flat and pitched roof terminations, using a concentric flue to run vertically from the top of the boiler and terminating above roof level.

Connection to the top of the boiler is made using a separately supplied vertical connector.

#### WEATHER PROOFING

Where the flue passes through the roof line an adequate seal must be made. This is achieved by using either:

- Flat roof weather collar
- or
- Universal weather collar.

#### ACCESSORIES

Flue Duct Extension Kits are available for flue lengths extending beyond 1m. These packs contain 500mm, 1000mm and 2000mm extension ducts and may be cut to the desired length.

If the offset vertical option is used an elbow Kit is required.

For a full accessories list refer to [www.idealboilers.com](http://www.idealboilers.com).

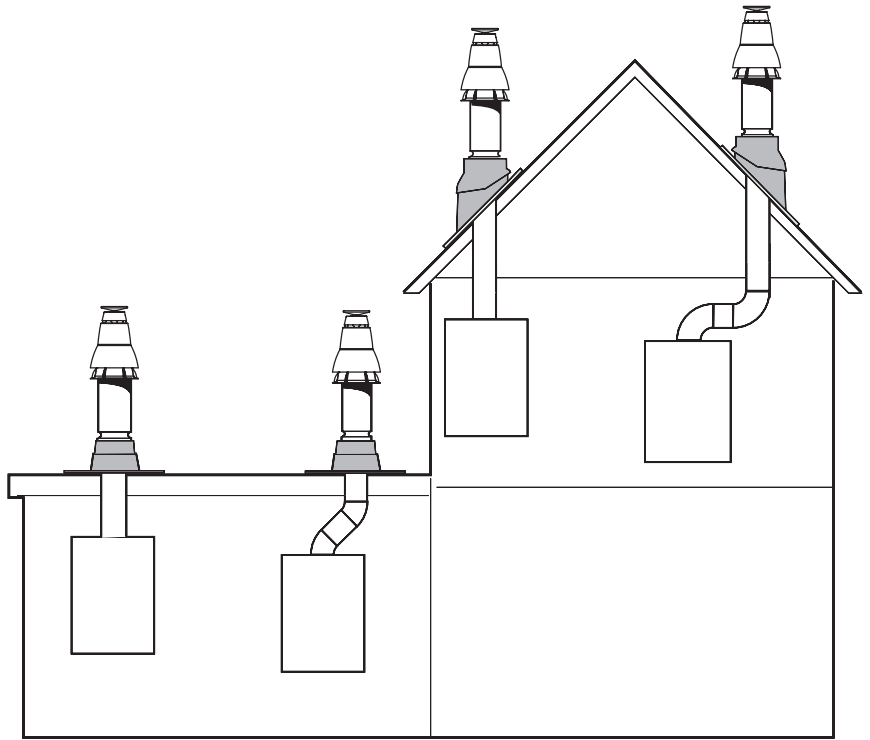

## SECTION 2 - INSTALLATION

### 2.17 FLUE TERMINAL POSITION

The terminal should be positioned so that products of combustion can safely disperse at all times.

Plumbing may occur at the termination so, where possible, terminal positions where this could cause a nuisance should be avoided.

Minimum dimensions are shown below

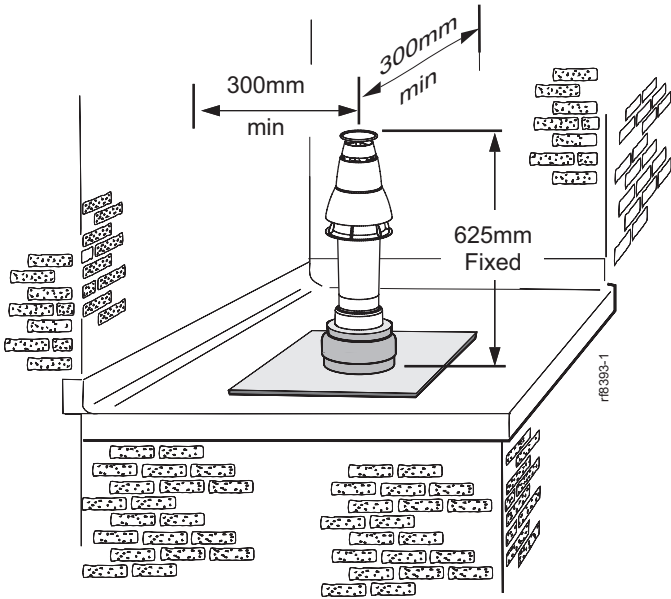

**Flat roof - with structure**

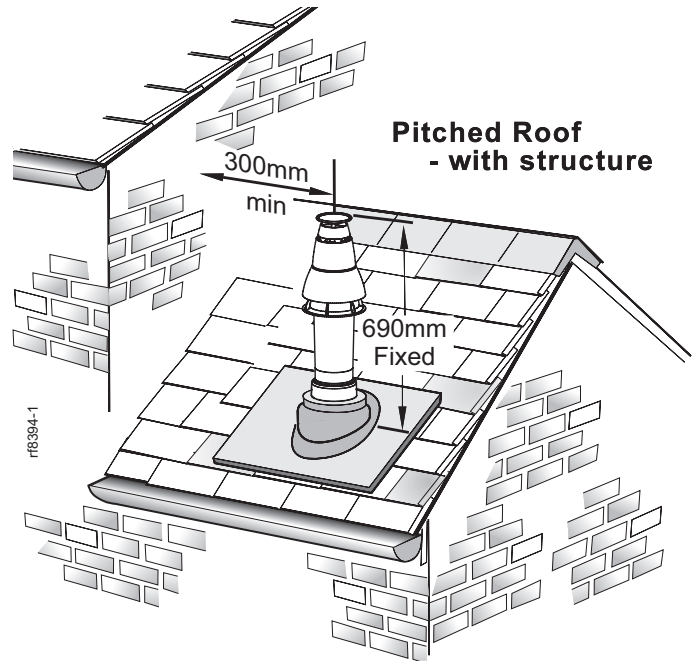

**Pitched Roof - with structure**

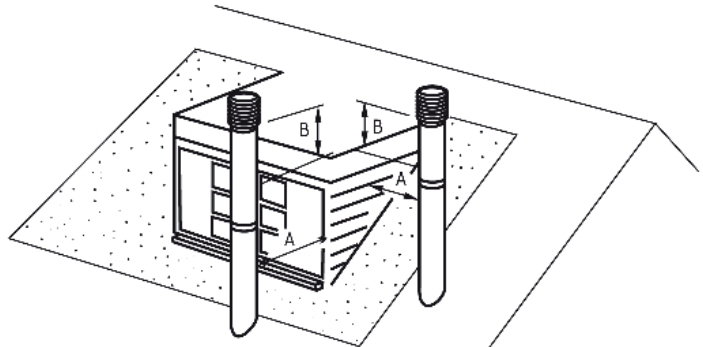

If chimney penetrates dotted area such that A is less than 300mm, B shall not be less than 300mm.

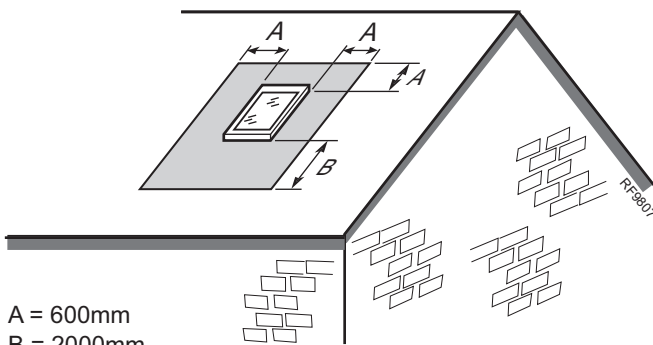

A = 600mm  
B = 2000mm

The flue terminal shall not penetrate the shaded area of the roof

**Pitched roof - with velux window or opening**

Where two or more vertical fanned draught chimney configurations terminate in close proximity at the same height, they shall be separated by at least 300mm. Where any one vertical outlet is more than 300mm above the other, then they shall be separated by at least 1500mm.

Where any vertical fanned draught chimney configuration outlet is within 2000mm measured horizontally of an opening window, then it shall be at least 300mm above the opening.

**Note.**

The equivalent flue length resistance of the elbow kits are:

90° elbow kit = 1m

45° elbow kit = 0.6m

FLUE OUTLET

## SECTION 2 - INSTALLATION

### 2.18 ASSEMBLING THE ROOF FLUE KIT

Determine the correct height that the flue should terminate above the roof. If after calculating or measuring the overall flue height from the top of the boiler, it is necessary to cut both pipes of assembly A, then ensure they are cut equally leaving the inner flue tube longer than the outer air tube as supplied.

Ensure the cut pipe ends are free from any burrs.

1. Position the roof flashing plate (supplied separately) over the hole cut in the roof and insert flue terminal from the roof end.

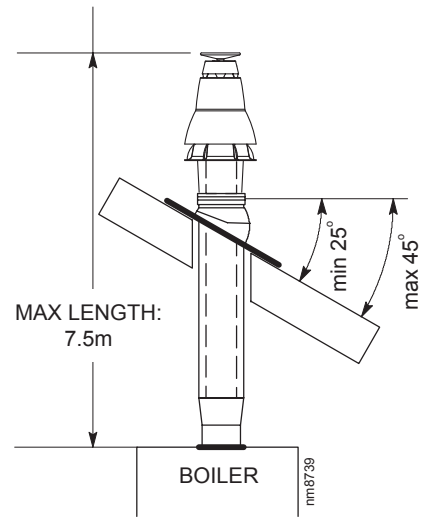
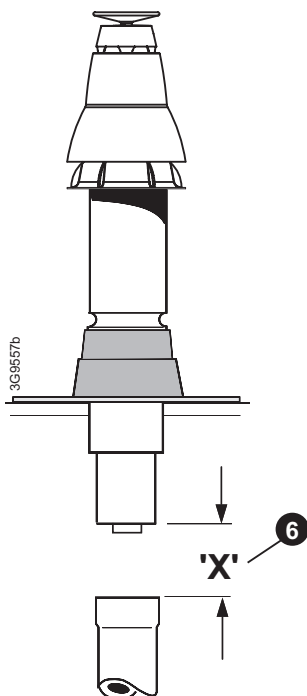
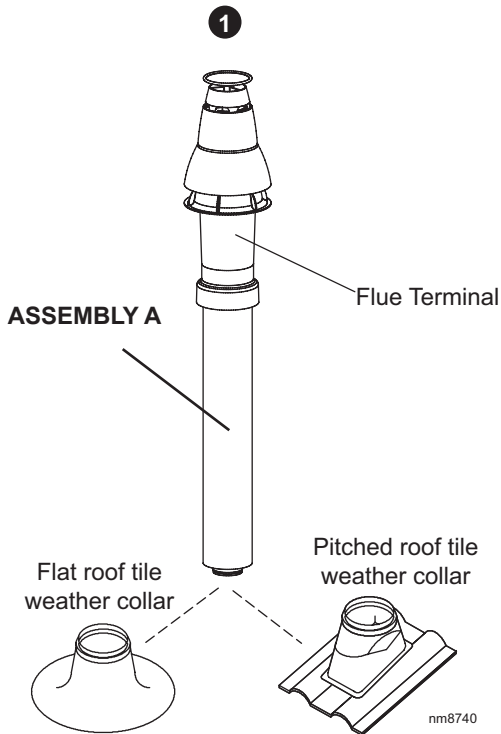

2. Fit the vertical connector (supplied in kit) in accordance with the instructions provided with the vertical connector kit.
3. Secure the vertical connector by applying downward pressure on the connector.
4. Position the clamp on the top face of the flue manifold and push it horizontally backwards. Locate both clamp lugs into the flue manifold and secure to the flue manifold with the M5 retaining screw.
5. Push extension duct if required (supplied separately) into vertical connector.

**Note.** Ensure turret sample points are servicable and all caps and plugs are fitted. Fill the condensate trap/siphon with water.

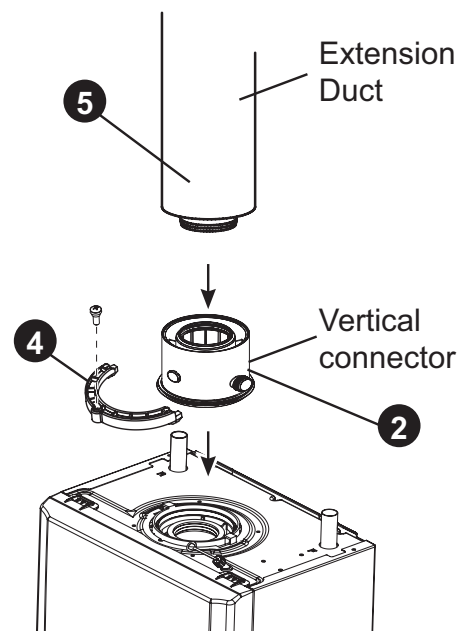

6. If the last extension duct requires cutting, measure 'X', the distance (outer ducts), between the duct and the terminal and add 100 mm to this dimension. This gives the length of the last extension duct.

**Note.** Check the position of the inner flue duct relative to the outer duct on the assembled extension duct(s) and ensure the terminal flue duct is cut longer than the air duct to ensure engagement in the final flue duct seal.

7. Finally ensure the roof flashing plate is correctly sealed to the roof.

2.19 CONDENSATE DRAIN

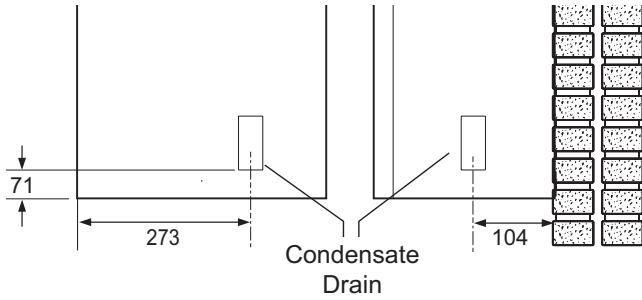

This appliance is fitted with a siphonic 75mm condensate trap system that requires filling before operating the appliance for the 1st time or after maintenance.

All condensate pipework should conform to the following:

- Where a new or replacement boiler is being installed, access to an internal 'gravity discharge' termination should be one of the main factors considered in determining boiler location.
- Plastic with push fit or solvent connections.
- Internal plastic pipe work a minimum of 19mm ID (typically 22mm OD)
- External plastic pipe must be a minimum of 30mm ID (typically 32 OD) before it passes through the sleeved wall.
- All horizontal pipe runs, must fall a minimum of 45mm per metre away from the Boiler.
- External & unheated pipe work should be kept to a minimum and insulated with Class "O" waterproof pipe insulation.
- All installations must be carried out in accordance to the relevant connection methods as shown in the "Condensate installation diagrams" & BS6798:2009
- Pipe work must be installed so that it does not allow spillage into the dwelling in the event of a blockage (through freezing)
- All internal burrs should be removed from the pipe work and any fittings.

In order to minimise the risk of freezing during prolonged very cold spells, one of the following methods of terminating condensate drainage pipe should be adopted.

**Internal Drain Connections**

Wherever possible, the condensate drainage pipe should be routed to drain by gravity to a suitable internal foul water discharge point such as an internal soil and vent stack or kitchen or bathroom waste pipe etc. See Figs 1 and 2.

**Condensate Pump**

Where gravity discharge to an internal termination is not physically possible or where very long internal pipe runs would be required to reach a suitable discharge point, a condensate pump of a specification recommended by the boiler or pump manufacturer should be used terminating into a suitable internal foul water discharge point such as an internal soil and vent stack or internal kitchen or bathroom waste pipe etc. (fig 3).

**External Drain Connections**

The use of an externally run condensate drainage pipe should only be considered after exhausting all internal termination options as described previously. An external system must terminate at a suitable foul water discharge point or purpose designed soak away. If an external system is chosen then the following measures must be adopted:

The external pipe run should be kept to a minimum using the most direct and "most vertical" route possible to the discharge point, with no horizontal sections in which condensate might collect.

- For connections to an external soil/vent stack see Fig 4. Insulation measures as described should be used.
- When a rainwater downpipe is used, an air break must be installed between the condensate drainage pipe and the downpipe to avoid reverse flow of rainwater into the boiler should the downpipe become flooded or frozen, see Fig 5.
- Where the condensate drain pipe terminates in a purpose designed soak away (see BS6798) any above ground condensate drain pipe sections should be run and insulated as described above. See Fig 6.
- Where the condensate drain pipe terminates over an open foul drain or gully, the pipe should terminate below the grating level, but above water level, to minimise "wind chill" at the open end. The use of a drain cover (as used to prevent blockage by leaves) may offer further prevention from wind chill.

**Unheated Internal Areas**

Internal condensate drain pipes run in unheated areas, e.g. lofts basements and garages, should be treated as external pipe.

Ensure the customer is aware of the effects created by a frozen condensate and is shown where this information can be found in the user manual.

**Figure 1 - Connection of Condensate Drainage Pipe to Internal Soil & Vent Stack**

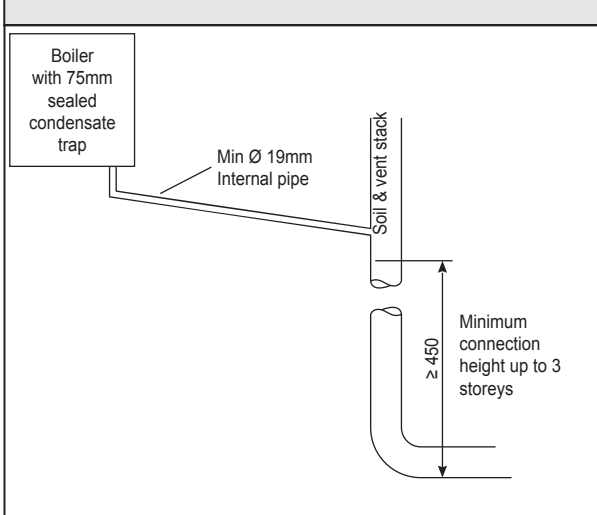

**Figure 2 - Connection of a Condensate Drainage Pipe Downstream of a Sink, Basin, Bath or Shower Water Trap to Internal Soil Vent Stack**

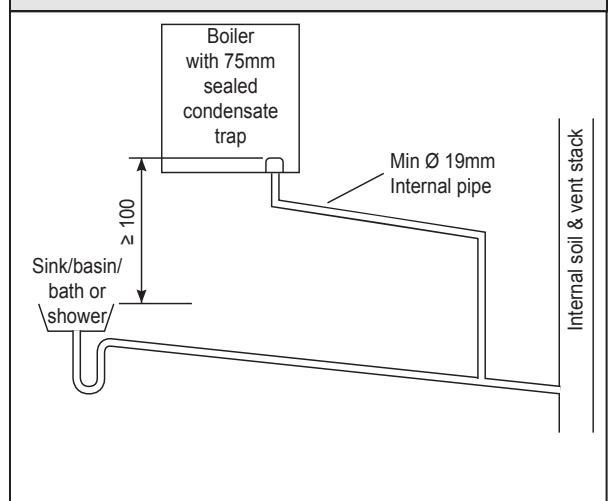

continued . . . . .

## SECTION 2 - INSTALLATION

### CONDENSATE DRAIN - CONT'D.....

**Figure 3** - Connection of a Condensate Pump Typical Method (see manufacturers detailed instructions)

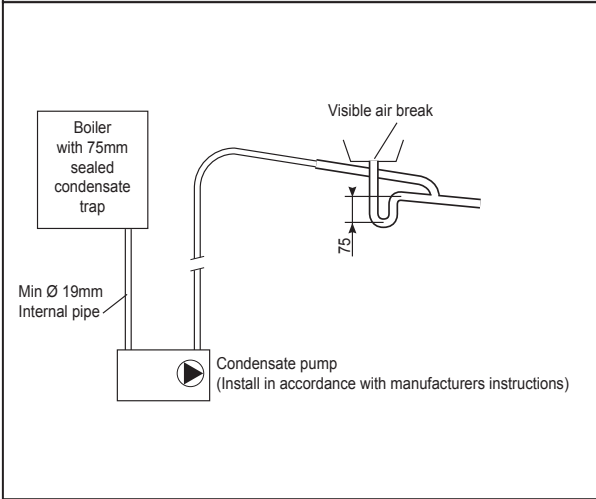

**Figure 4** - Connection of condensate Drainage Pipe to External Soil & Vent Stack

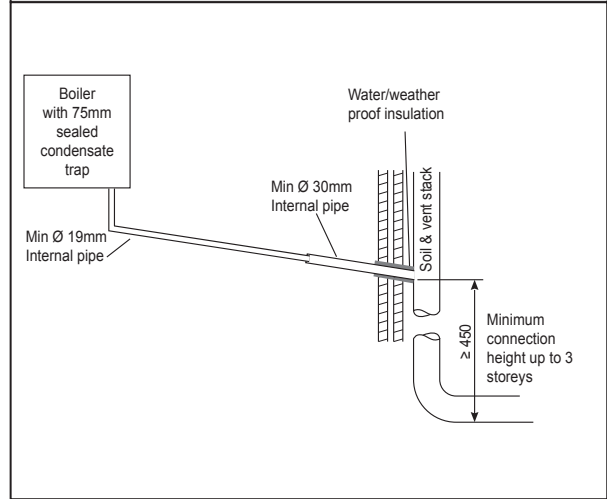

**Figure 5** - Connection of a Condensate Drainage Pipe to an External Rainwater Downpipe (only combined foul/rainwater drain)

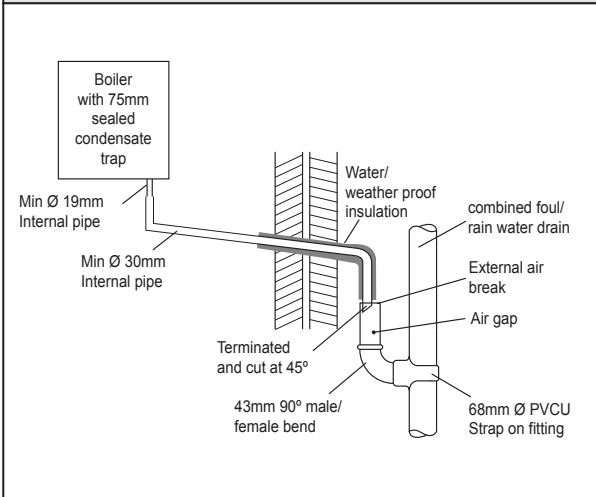

**Figure 6** - Connection of a Condensate Drainage Pipe to an External Purpose Made Soak Away.

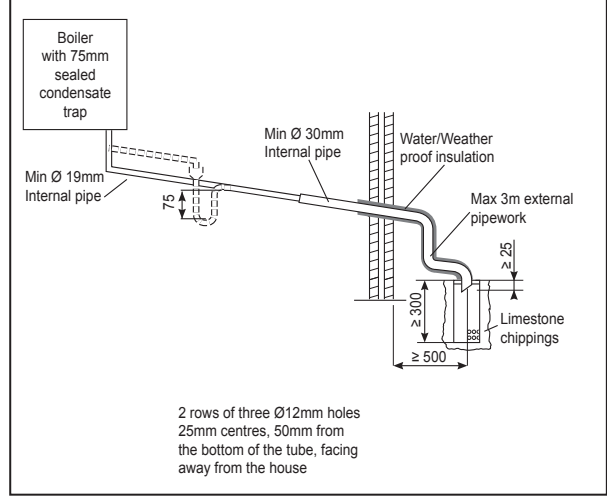

## 2.20 CONNECTIONS

### NOTES.

Ensure all pipe blanking plugs are removed before connecting.

### WATER CONNECTIONS

The boiler flow and return pipes are supplied fitted to the boiler and ready for top connection.

#### Top Connection

Connect the system pipework to the boiler flow and return pipes.

An optional stand-off kit is available where system pipework needs to be taken downwards.

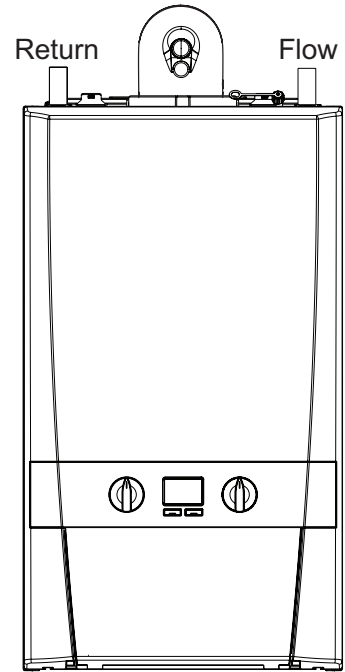

### GAS CONNECTION

**IMPORTANT.** The gas service cock is sealed with a non-metallic blue fibre washer, which must not be overheated when making capillary connections. Refer to Section 1.16 for details of the position of the gas connection.

For additional gas supply information refer to "Gas Supply" on page 12.

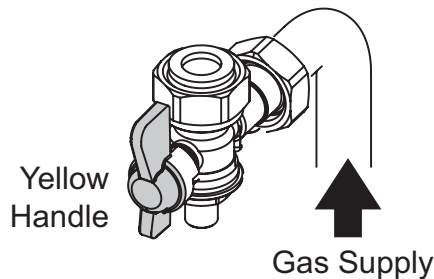

*Note. The gas isolation handle is shown in the open position.*

205862-10073

## 2.21 ELECTRICAL CONNECTIONS

**WARNING.** This appliance **MUST** be earthed.

A mains supply of 230Vac ~ 50 Hz is required.

The fuse rating should be 3A. All external controls and wiring must be suitable for mains voltage.

Wiring external to the boiler **MUST** be in accordance with the current I.E.E. (BS.7671) Wiring Regulations and any local regulations.

Wiring should be 3 core PVC insulated cable, not less than 0.75mm<sup>2</sup> (24 x 0.2mm), and to BS 6500 Table 16. For IE reference should be made to the current ETCI rules for electrical installations.

The mains supply to the boiler and system wiring centre shall be through one common fused double pole isolator. For heating systems, and where practicable replacement boiler installations, the isolator shall be situated adjacent to the appliance.

**NOTE. THE APPLIANCE MUST BE WIRED WITH A PERMANENT LIVE SUPPLY. THE BOILER WARRANTY WILL BE INVALID IF THIS REQUIREMENT IS NOT COMPLIED WITH.**

## SECTION 2 - INSTALLATION

### 2.22 INSTALLER WIRING

The boiler must be connected to a permanent live supply which must NOT be switched by thermostats / programmers.

To install the mains cable;

1. Isolate the mains supply to the boiler.
2. Remove the front panel. Refer to Section 3.2.
3. Swing the control box down into the service position, unclip and swing back the installer wiring cover to latch into the retaining clips. Refer to Section 3.8.
4. Route incoming cable through a grommet in the bottom panel, (note that the grommets are "blind" and will require puncturing) and securing using the strain relief.

5. Connect the mains cable to the terminal block as shown.
6. Close the installer wiring cover ensuring that it is located correctly and that the cable is retained into the strain relief as shown.
7. Swing the control box back up into the operating position and re-fit the front panel ensuring a good seal is made.

**NOTE.** When making the mains electrical connections to the boiler it is important that the wires are prepared in such a way that the earth conductor is longer than the current carrying conductors, such that if the cord anchorage should slip, the current carrying conductors become taut before the earthing conductor.

**INSTALLER CONNECTIONS (LHS)**

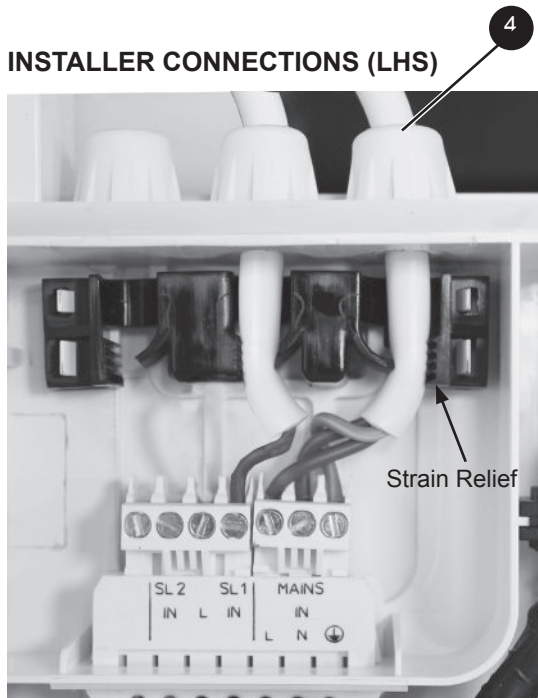

**INSTALLER CONNECTIONS (RHS)**

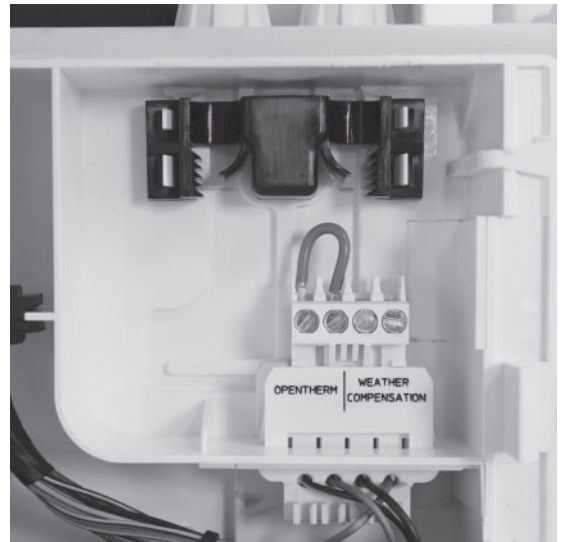

#### Frost Protection

If parts of the pipework run outside the house or if the boiler will be left off for more than a day or so then a frost thermostat should be wired into the system.

The frost thermostat should be sited in a cold place but where it can sense heat from the system.

**Note.** If the boiler is installed in a garage it may be necessary to fit a pipe thermostat, preferably on the return pipework.

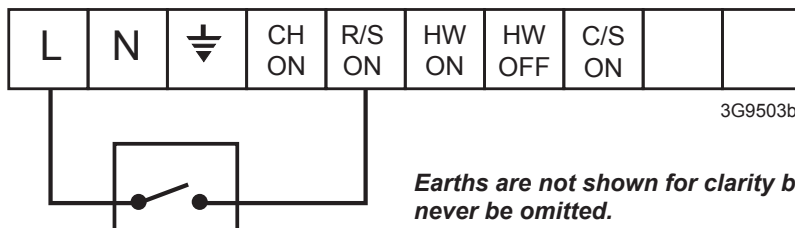

**Earths are not shown for clarity but must never be omitted.**

## SECTION 2 - INSTALLATION

### 2.23 INSTALLER WIRING PLAN DIAGRAMS

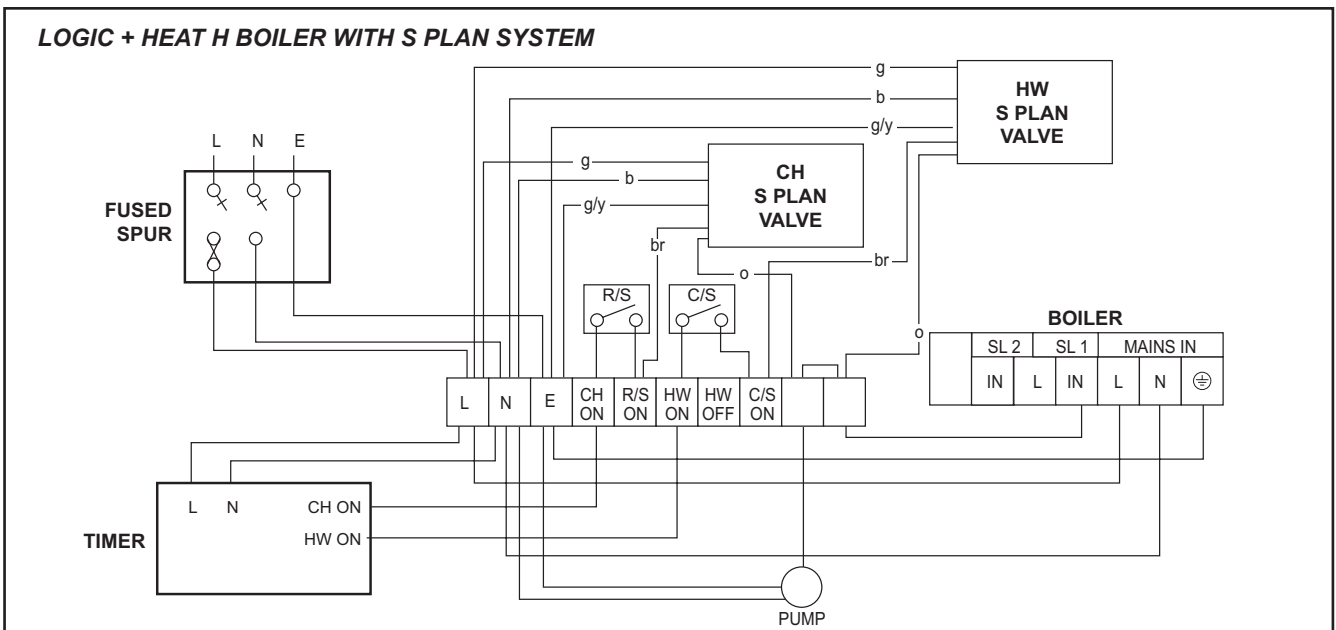
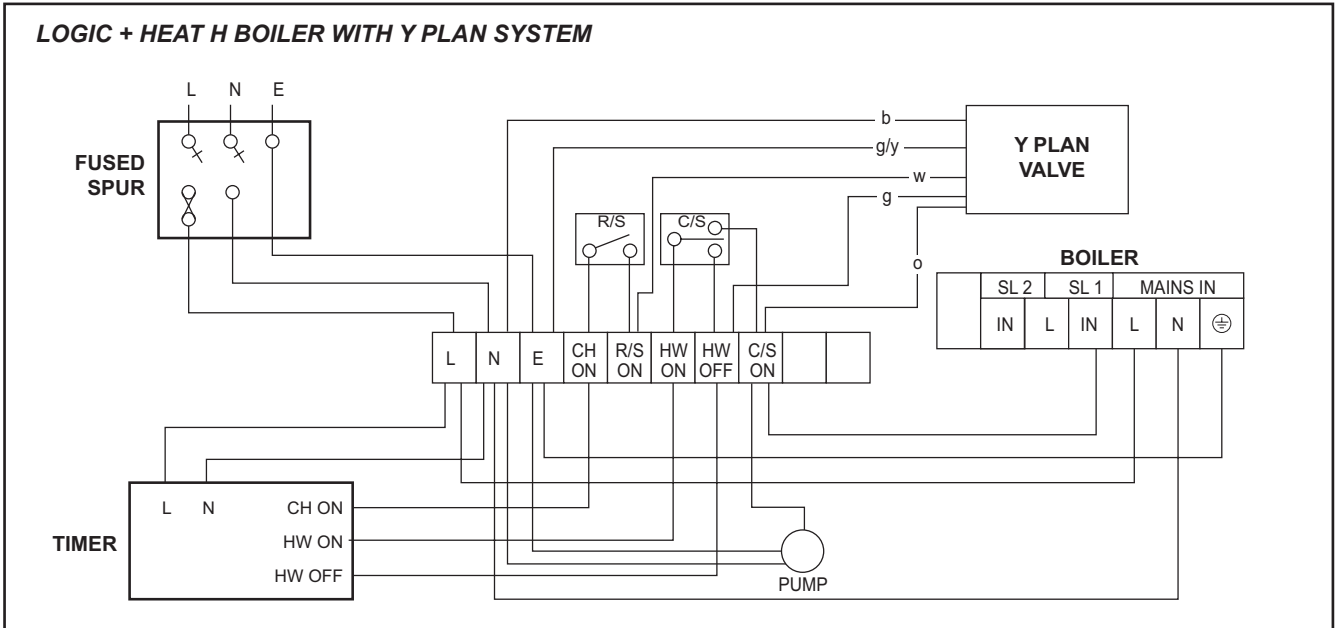

# SECTION 2 - INSTALLATION

## 2.24 WIRING DIAGRAM

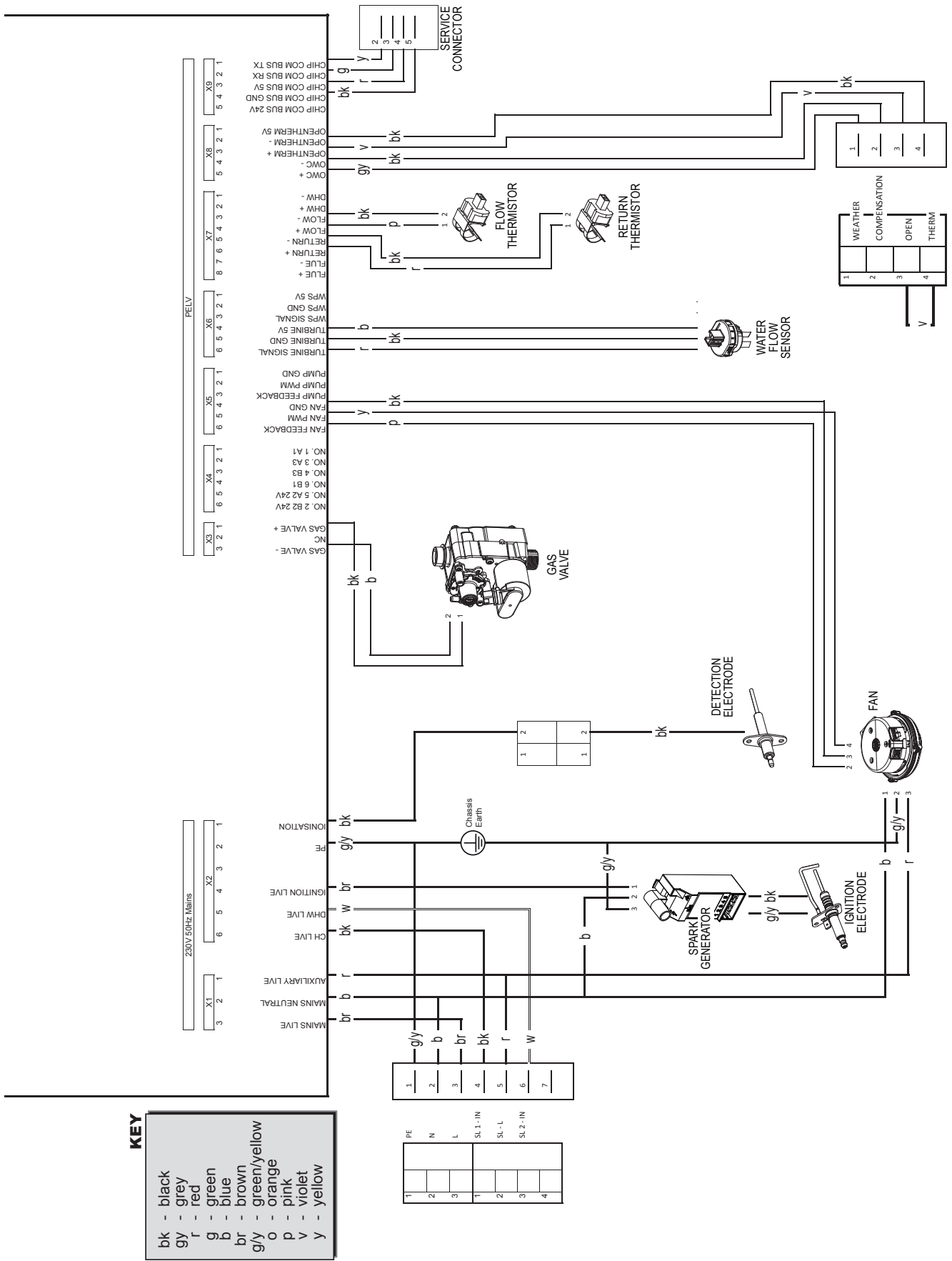

### 2.25 COMMISSIONING AND TESTING

#### A. Electrical Installation

1. Checks to ensure electrical safety should be carried out by a competent person.
2. ALWAYS carry out the preliminary electrical system checks, i.e. earth continuity, polarity, resistance to earth and short circuit, using a suitable test meter.
3. After wiring the boiler, all grommets in the bottom panel MUST be in place to ensure that the boiler case sealing is maintained.

#### B. Gas Installation

1. The whole of the gas installation, including the meter, should be inspected and tested for tightness and purged in accordance with the recommendations of BS. 6891. In IE refer to IS.813:2002.
2. Purge air from the gas installation by the approved methods only.

**WARNING.** Whilst effecting the required gas tightness test and purging air from the gas installation, open all windows and doors, extinguish naked lights and **DO NOT SMOKE.**

#### GENERAL

**Please Note:** The combustion for this appliance has been checked, adjusted and preset at the factory for operation on the gas type defined on the appliance data plate. **DO NOT** adjust the air/gas ratio valve.

Having checked:

- That the boiler has been installed in accordance with these instructions.
- The integrity of the flue system and the flue seals, as described in the Flue Installation section.

Proceed to put the boiler into operation as follows:

#### CHECK THE OPERATIONAL (WORKING) GAS INLET PRESSURE

Set up the boiler to operate at maximum rate.

With the boiler operating in the maximum rate condition check that the operational (working) gas pressure at the inlet gas pressure test point complies with the requirements - refer to "Gas Supply" on page 12.

Ensure that this inlet pressure can be obtained with all other gas appliances in the property working.

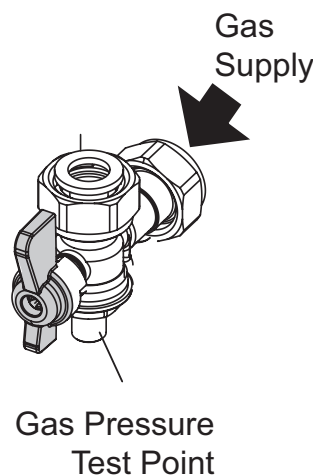

**As part of the commissioning process, the combustion of this appliance must be checked and the Benchmark Checklist completed. A flow chart to assist is provided on page 65.**

**ATTENTION !**  
**IT IS A CONDITION OF THE MANUFACTURERS WARRANTY THAT THE BENCHMARK COMMISSIONING CHECKLIST IS FULLY COMPLETED AND LEFT WITH THE APPLIANCE**

### 2.26 INITIAL LIGHTING

**Legend**

- A. Central Heating Temperature Knob
- B. Mode Knob
- C. Boiler Status
- D. Burner 'on' Indicator
- E. Central Heating Economy Setting
- F. RESTART Button
- G. Function Button
- H. Gas Inlet Pressure Test Point
- J. Gas Service Cock

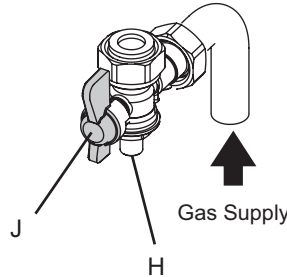
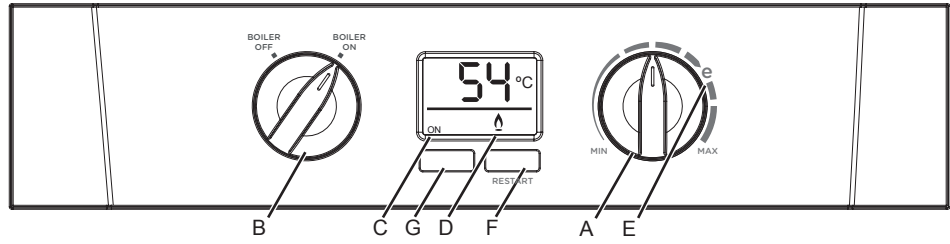

1. Check that the system has been filled and that the boiler is not airlocked.

**Note.**

*It is important the burner is not operated before the system is fully vented of air. If it is necessary to operate the system pump to assist venting of the air this must be done with the gas service cock turned off.*

2. Refit the boiler front panel. Refer to Section 3.2.
3. Check that the electrical supply is OFF.
4. Check that the boiler mode knob (B) is OFF.
5. Check that the gas service cock (J) is OPEN.
6. Slacken the screw in the inlet pressure test point (H) and connect a gas pressure gauge via a flexible tube.
7. Switch the electricity supply ON and check all external controls are calling for heat.

**CENTRAL HEATING**

8. Set the CH temp knob (A) to max and turn the mode knob (B) to "BOILER ON". The boiler control should now go through its ignition sequence until the burner is established.
9. If the boiler does not light then after 5 attempts the boiler will lock out and display fault code  $L2$ .

Restart the boiler (Refer to Section 2.28). The boiler will repeat its ignition sequence. If restart occurs 5 times within 15 minutes then  $L2$  will be shown. If power is removed this will be restarted.

When the burner is established the '🔥' will be shown on the display with the word 'ON' indicating central heating operation and the current flow temperature shown in the 2 digit display.

10. Ensure that with the boiler operating the dynamic gas pressure is able to obtain maximum output. Refer to Table 2.

**IMPORTANT**

**The gas input to the burner is regulated by the gas valve according to the air flow produced by the fan. It is NOT user-adjustable. Any interference to sealed settings on the gas valve will adversely affect operation and render our warranty void.**

For additional gas supply information refer to "Gas Supply" on page 12.

11. Remove gas pressure gauge, tighten inlet pressure test point and check for gas tightness.

**THE DISPLAY**

The user control has one display to inform the user about the status of the boiler. The LCD shows the status of the flame. If no flame is detected the flame symbol will not be visible. When the flame is detected the flame symbol will be visible permanently.

Below is a list with display functions in normal operation.

- $\square\square$  Standby, no demand for heat present.
- ON There is a demand for heat.
- FP Boiler is active for boiler frost protection.
- $L$  Boiler is in lockout for a specific error. Display will show a number after the "L" to indicate which error is detected.
- F Boiler has a fault for a specific error. Display will show a number after the "F" to indicate which error is detected.

**Note:** Boiler frost protection - boiler operates if the ambient temperature is below 5°C until it reaches 19°C.

*Note. The boiler incorporates a fan overrun cycle which MUST NOT be prematurely interrupted by isolation of the mains electricity supply.*

## 2.27 GENERAL CHECKS

Make the following checks for correct operation:

### CENTRAL HEATING (CH) MODE

1. Ensure that the CH external controls are calling for heat.

The display should show:

🔥 'ON'

### 2. Gas Rate

Check the boiler gas rate when the boiler is at maximum output.

Check at the gas meter, with no other appliance in use.

Refer to Table 2 for gas rates.

3. Set the central heating external controls to OFF. The burner should go off and the pump continue to run for two minutes. The display should read: □□

4. Check the correct operation of the timer (if fitted) and all other system controls. Operate each control separately and check that the main burner responds.

### WATER CIRCULATION SYSTEM

1. With the system COLD, check that the initial pressure is correct to the system design requirements.  
For pre-pressurised systems, this should be 1.0 bar.
2. With the system HOT, examine all water connections for soundness. The system pressure will increase with temperature rise but should not exceed 2.5 bar.
3. With the system still hot, turn off the gas, water and electricity supplies to the boiler and drain down to complete the flushing process.  
**Note:** A flushing solution should be used during the flushing procedure. Flushing solutions: Fernox Superfloc, Sentinel X300 (new systems) or X400 (existing systems). Refer to Section 1.22.
4. Refill and vent the system, add inhibitor (see Section 1.22), clear all air locks and again check for water soundness.
5. Reset the system initial pressure to the design requirement.
6. Balance the system. Refer to Section 1.21.
7. Check the condensate drain for leaks and check that it is discharging correctly.
8. Finally, set the controls to the User's requirements.

Knob Setting	CH Flow Temp °C
Max	80
Min	30

### WATER TEMPERATURES

Temperatures can be selected using the CH temperature control (A)

## 2.28 RESTART PROCEDURE

To restart boiler, press the "RESTART" Button (F).

### Legend

- A. Central Heating Temperature Knob
- B. Mode Knob
- C. Boiler Status
- D. Burner 'on' Indicator
- E. Central Heating Economy Setting
- F. RESTART Button
- G. Function Button

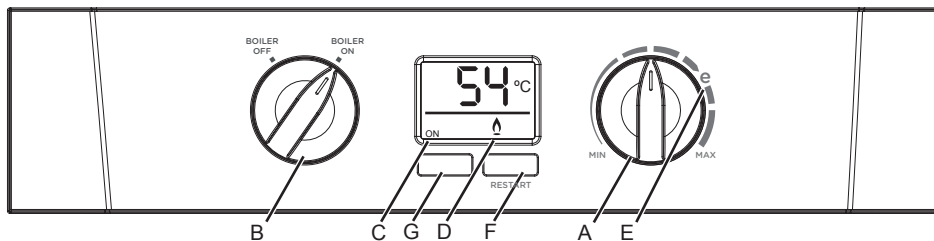

### 2.29 ACCESSING THE INSTALLER MODE

To access Installer Mode press the function button and "RESTART" Buttons together for more than 5s.

1. The last 3 faults will be shown  
See Section 4.1 for Fault Code descriptions
2. "SL" will be shown  
To run the burner at minimum rate press "RESTART", otherwise press the function button.
3. "SH" will be shown  
To run the burner at maximum rate press "RESTART", otherwise press the function button.
4. "VF" will be shown  
press the function button.
5. "dU" will be shown  
press the function button.
6. "P1" will be shown  
Press the function button.
7. "P7" will be shown  
Press the function button.
8. "FL" will be shown  
This feature is not required on this appliance. Press the function button.
9. "SE" will be shown  
This feature is not required on this appliance. Press the function button to exit.

### 2.30 HANDING OVER

**After completing the installation and commissioning of the system the installer should hand over to householder by the following actions:**

1. Hand the User Instructions to the householder and explain his/her responsibilities under the relevant national regulations.
2. Explain and demonstrate the lighting and shutting down procedures.
3. The operation of the boiler and the use and adjustment of all system controls should be fully explained to the householder, to ensure the greatest possible fuel economy consistent with the household requirements of both heating and hot water consumption.  
Advise the User of the precautions necessary to prevent damage to the system and to the building, in the event of the system remaining inoperative during frosty conditions.
4. Explain the function and the use of the boiler heating controls.
5. Explain the function of the boiler fault mode.  
Emphasise that if a fault is indicated refer to "Fault Codes" in the User Guide.
6. Explain and demonstrate the function of time and temperature controls, radiator valves etc., for the economic use of the system.
7. If a timer is fitted draw attention to the timer Users Instructions and hand them to the householder.
8. Explain Boiler restart procedure.
9. After installation and commissioning please complete the Benchmark Commissioning Checklist before handover to the customer. For IE, its is necessary to complete a "Declaration of Conformity" to indicate compliance to I.S. 813:2002.

**IMPORTANT**

10. A comprehensive service should be carried out ANNUALLY.  
Stress the importance of regular servicing by a Gas Safe Registered Engineer. In IE servicing work must be carried out by a Registered Gas Installer (RGII).
11. Inform the householder of the guarantee/registration found within the envelope pack and the requirement to register it to receive the full benefit of the warranty.

## 3.1 SERVICING SCHEDULE

For the very latest copy of literature for specification & maintenance practices, visit our website [www.idealboilers.com](http://www.idealboilers.com), where you will be able to download the relevant information.

**WARNING.** Always turn OFF the gas supply at the gas service cock, and switch OFF and disconnect the electricity supply to the appliance before servicing.

**Combustion testing must be carried out by a competent person using a combustion analyser conforming to BS7927.**

To ensure the continued safe and efficient operation of the appliance it is recommended that it is checked at regular intervals and serviced as necessary. The frequency of servicing will depend upon the installation condition and usage but should be carried out at least annually.

It is the law that any service work must be carried out by a Gas Safe Registered Engineer. In IE service work must be carried out by a Registered Gas Installer (RGI).

**Note.** In order to carry out either servicing or replacement of components the boiler front panel must be removed. Refer to Section 3.2.

### PRELIMINARY INSPECTION

1. Light the boiler and carry out a pre-service check, noting any operational faults (refer to appropriate fault finding chart as necessary).
2. Check the flue terminal (and terminal guard if fitted) is undamaged and clear of any obstruction.
3. Check combustion by connecting the flue gas analyser to the flue gas sampling point as shown in the diagram and measure CO and CO<sub>2</sub> at maximum rate. To set the boiler to Maximum and Minimum heat inputs see page 64. Repeat at minimum rate.

If the CO / CO<sub>2</sub> ratio is greater than 0.004 please proceed to "Cleaning Procedure".

If the CO / CO<sub>2</sub> ratio is less than 0.004 please proceed to "Check Procedure".

### CHECK PROCEDURE

1. Check all water and gas joints for signs of leakage. Remake any suspect joints ensuring a gas tightness check is carried out if applicable and the water system is correctly refilled, vented and re-pressurised.
2. Proceed to "IMPORTANT".

### CLEANING PROCEDURE

1. Clean the main burner. Refer to Section 3.4.
2. Clean the heat exchanger & condensate trap/siphon. Refer to Section 3.5 & 3.6.
3. Check the main injector for blockage or damage. Refer to Section 3.3.
4. The cleaning procedures are covered more fully in Sections 3.3 - 3.6 and MUST be carried out in sequence.
5. Proceed to "IMPORTANT".

**Do not operate the boiler if the front panel is not fitted.**

### IMPORTANT

1. If, for any reason, the condensate trap/siphon has been removed, ensure the trap is refilled with water before re-assembling.
2. After completing the servicing or exchange of components always ensure all gas valve connections are gas tight with a gas soundness check up to the gas control valve.
3. When work is complete the front panel MUST be correctly refitted, ensuring that a good seal is made.
4. Complete the service section in the Benchmark Commissioning Checklist.

### GENERAL

**Please Note:** During routine servicing, and after any maintenance or change of part of the combustion circuit, the following must be checked:

- The integrity of the flue system and the flue seals,
- The integrity of the boiler combustion circuit and the relevant seals
- The operational (working) gas inlet pressure at maximum rate.
- The gas rate
- The combustion performance.

### COMPETENCE TO CARRY OUT THE CHECK OF COMBUSTION PERFORMANCE

**Please Note:** BS 6798:2009 Specification for installation and maintenance of gas-fired boilers of rated input not exceeding 70kW net advises that:

- The person carrying out a combustion measurement should have been assessed as competent in the use of a flue gas analyser and the interpretation of the results.
- The flue gas analyser used should be one meeting the requirements of BS7927 or BS-EN50379-3 and be calibrated in accordance with the analyser manufacturer's requirements, and
- Competence can be demonstrated by satisfactory completion of the CPA1 ACS assessment, which covers the use of electronic portable combustion gas analysers in accordance with BS7967, Parts 1 to 4.

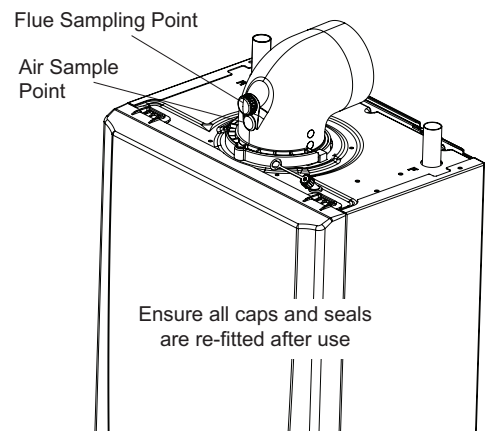

## SECTION 3 - SERVICING

### 3.2 BOILER FRONT PANEL REMOVAL / REPLACEMENT

#### REMOVAL

1. Loosen the two screws retaining the front panel.
2. Pull the two clips down to disengage and pull panel forward and upward and remove.

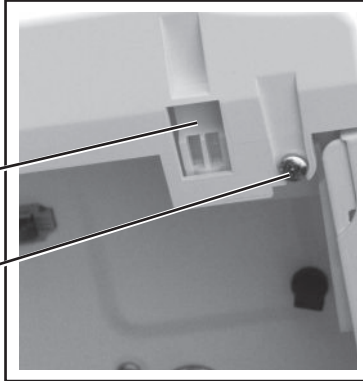

view from bottom of boiler

#### REPLACEMENT

3. Hook the panel onto the top retaining clips.
4. Push the panel until the 2 bottom spring clips engage ensuring the 4 control knobs line up with the holes in the front panel.
5. Re-tighten the two retaining screws.

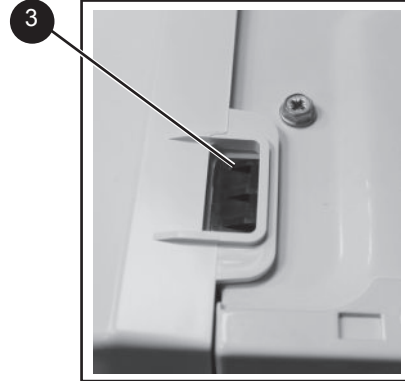

view from top of boiler

### 3.3 FAN AND VENTURI ASSEMBLY REMOVAL AND CLEANING

1. Disconnect the electrical leads from the fan.
2. Remove the clip from the gas control valve outlet and ease the pipe upwards. Rotate and then ease down to remove.
3. Remove the extended nut on the fan mounting bracket.
4. Lift off fan and venturi assembly.
5. Undo the two M4 screws and release the nozzle assembly.
6. Inspect the injector for blockage or damage.
7. Inspect fan outlet sealing gasket and replace if necessary.

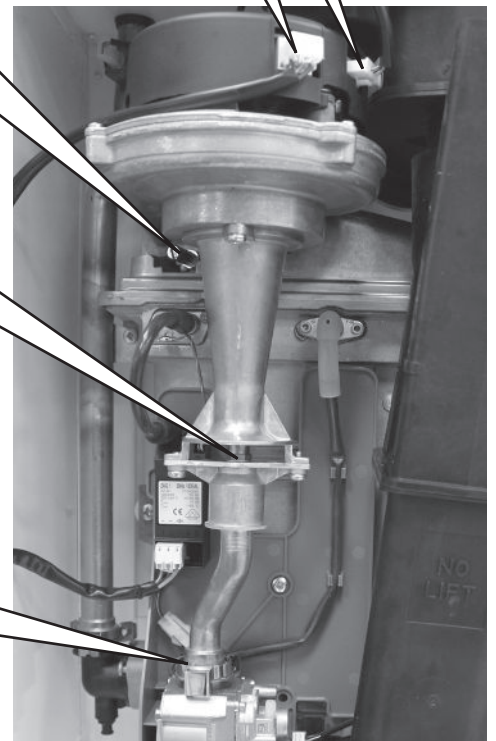
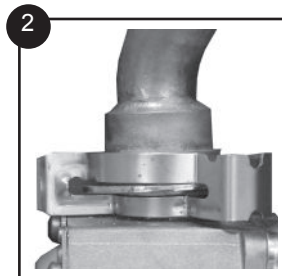
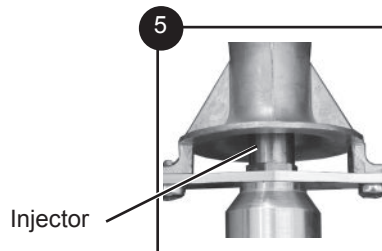
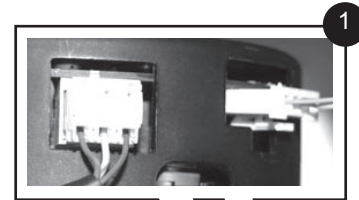

## SECTION 3 - SERVICING

### 3.4 BURNER REMOVAL AND CLEANING

1. Ensure the sump is fully drained
2. Undo the two screws and remove the sump cover retaining the lower flue manifold.
3. Lift the manifold to clear the bottom sealing gasket and remove manifold.
4. Remove the 2 burner front fixing screws and loosen the 2 rear extended nuts by at least ten turns.
5. Lift off the burner from the combustion chamber. To facilitate the removal angle the burner as shown.

#### IMPORTANT

The burner head is a ceramic plaque construction. Care must be taken to ensure that **the burner is not placed down upon its face** as this may cause damage to the ceramic.

6. Brush off any deposits that may be on the ceramic with a SOFT brush.
7. Inspect the sealing gasket around the burner for any signs of damage. Replace as necessary.

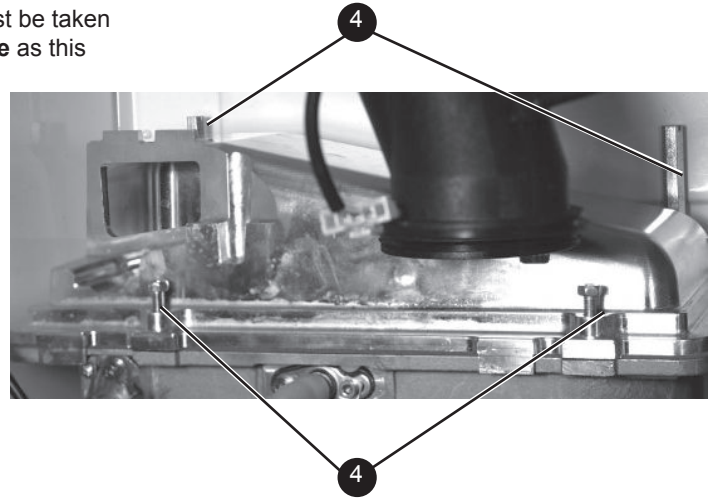
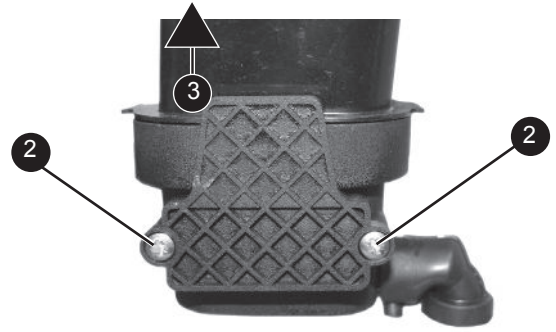

### 3.5 CLEANING THE CONDENSATE TRAP/SIPHON

1. Pull off the rubber pipe noting the position and flush out any deposits with clean water.
2. Replace the cleaning plug and refill the siphon with water.
3. Replace the rubber pipe connector with the twin wall seal fitted to the condensate siphon.

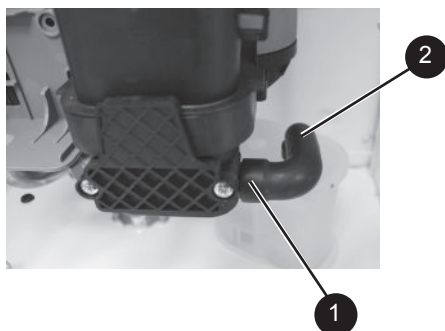

View from underside of boiler

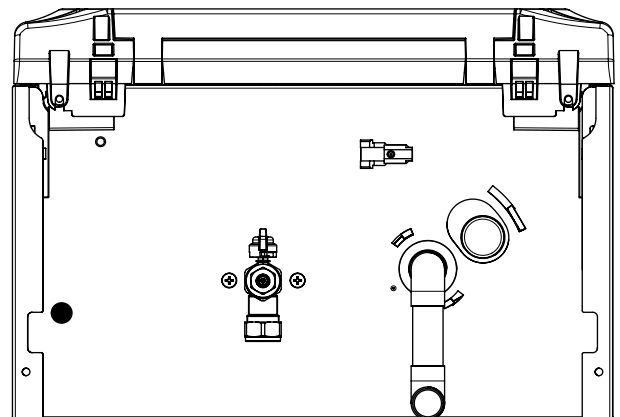

## SECTION 3 - SERVICING

### 3.6 CLEANING THE HEAT EXCHANGER

**Note:** Ensure the condensate trap/siphon is fully drained before cleaning. Refer to Section 3.5.

1. Remove ignition and flame detection electrodes. Refer to Sections 3.13 & 3.14.
2. It is advisable to replace the sump cover prior to the water flush process.
3. Thoroughly flush the heat exchanger by pouring water into the top of the combustion chamber ensuring the full top area is covered.
4. Remove the sump cover and clean loose deposits from the sump.
5. Inspect the ignition and detection electrodes. Ensure that they are clean and in good condition - replace if necessary.
6. Re-fit the ignition and flame detection electrodes, ensuring that the earth tab is fitted to ignition electrode.
7. Check that the ignition and detection gaps are correct. Refer to Sections 3.13 & 3.14.

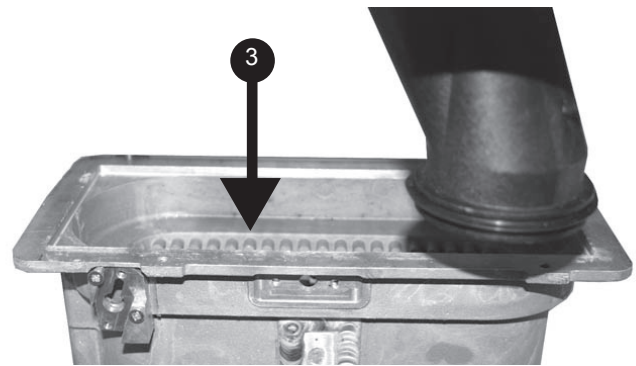
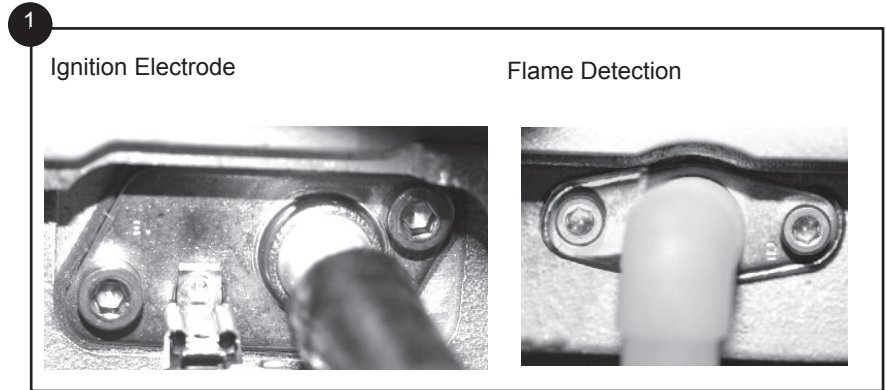

### 3.7 REASSEMBLY

Reassemble the boiler in the following order:

1. Ensure that the condensate trap/siphon is full of water.
  2. Refit the burner ensuring the sealing gasket is correctly positioned and free from damage (tighten the 4 fixing screws in the sequence shown below - A,B,C,D).
  3. Refit the fan / venturi assembly ensuring the retaining tabs are correctly positioned and the sealing gasket is correctly positioned and free from damage.
  4. Reconnect the fan electrical leads.
  5. Remove the sump cover and refit the lower flue manifold as shown.
  6. Refit the sump cover.
  7. Refit the boiler front panel.
- IMPORTANT.** Ensure that the boiler front panel is correctly fitted and that a good seal is made.
8. Swing the control box back into its working position and secure.
  9. Turn on the gas supply at the gas service cock.
  10. Reconnect the electrical supply.
  11. Check operation of the boiler. Refer to Sections 2.26 & 2.27.

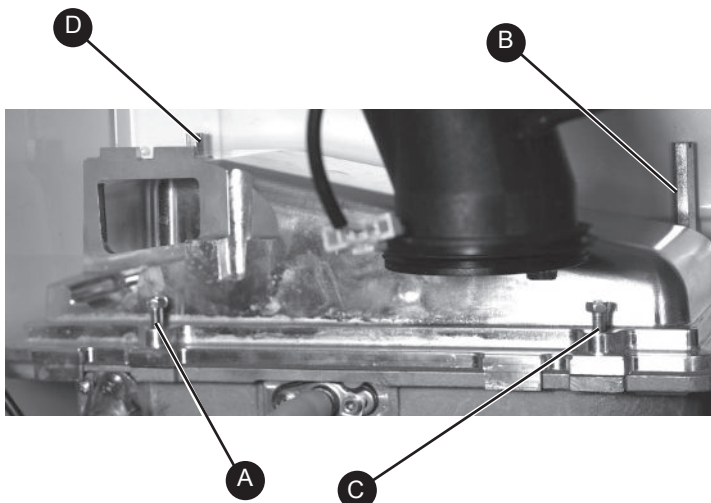

### 3.8 REPLACEMENT OF COMPONENTS

#### GENERAL

#### When replacing ANY component

1. Isolate the electricity supply.
2. Turn off the gas supply.
3. Remove the boiler front panel. Refer to Section 3.2.
4. Release the retaining clip and swing the control box down into the servicing position.

After replacing ANY component check operation of the boiler, including gas soundness, gas rate and combustion test.

#### IMPORTANT.

Ensure all gas valve connections are gas tight with a gas soundness check up to the gas control valve.

When work is complete, the front panel must be correctly refitted - ensuring that a good seal is made.

#### Notes.

1. In order to assist fault finding, the control panel has an LCD diagnostic display. The key to boiler fault conditions is shown in Section 4.
2. In order to replace components in Sections 3.19 to 3.20 it is necessary to drain the boiler. See Section 3.20, item no. 2.

**THE BOILER MUST NOT BE OPERATED WITHOUT THE FRONT PANEL FITTED**

### 3.9 FAN REPLACEMENT

1. Refer to Section 3.8.
2. Disconnect the electrical leads from the fan.
3. Remove the clip from the gas control valve outlet.
4. Remove the extended nut retaining the fan mounting bracket.
5. Lift and remove the fan and venturi assembly.
6. Remove the screw and twist venturi anti-clockwise to remove venturi assembly, *noting the orientation of the venturi in relation to the fan body.*
7. Transfer the venturi assembly to the new fan, replacing the 'o' ring if evidence of damage or deterioration is visible.
8. Fit the new fan / venturi assembly ensuring the retaining tabs are correctly positioned and the fan outlet sealing gasket is correctly positioned and free from damage. Refit the extended nut.
9. Reassemble the boiler in reverse order, taking care not to overtighten the screw on the fan mounting bracket and ensure all gas 'o' rings are in place
10. Check the operation of the boiler. Refer to Sections 2.26 & 2.27.

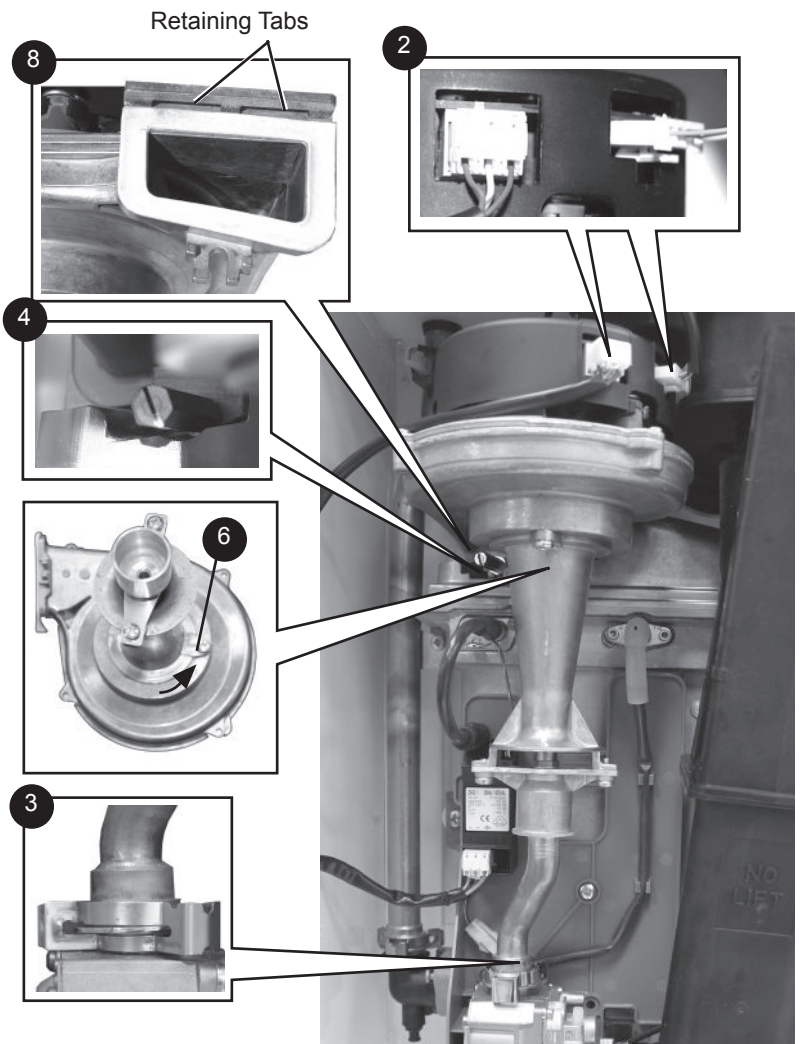

## SECTION 3 - SERVICING

### 3.10 BURNER INJECTOR REPLACEMENT

1. Refer to Section 3.8.
2. Disconnect the electrical leads from the fan.
3. Remove the clip from the gas valve to venturi pipe and ease the pipe upwards, rotate and ease down to remove.
4. Loosen the screw retaining the fan mounting bracket.
5. Lift and remove the fan and venturi assembly.
6. Remove the 2 injector housing screws.
7. Withdraw the injector housing.
8. Fit the new injector housing complete with injector.
9. Reassemble in reverse order, ensuring that the new gas seal supplied is located correctly in the injector housing.
10. Check operation of the boiler. Refer to Sections 2.26 & 2.27.

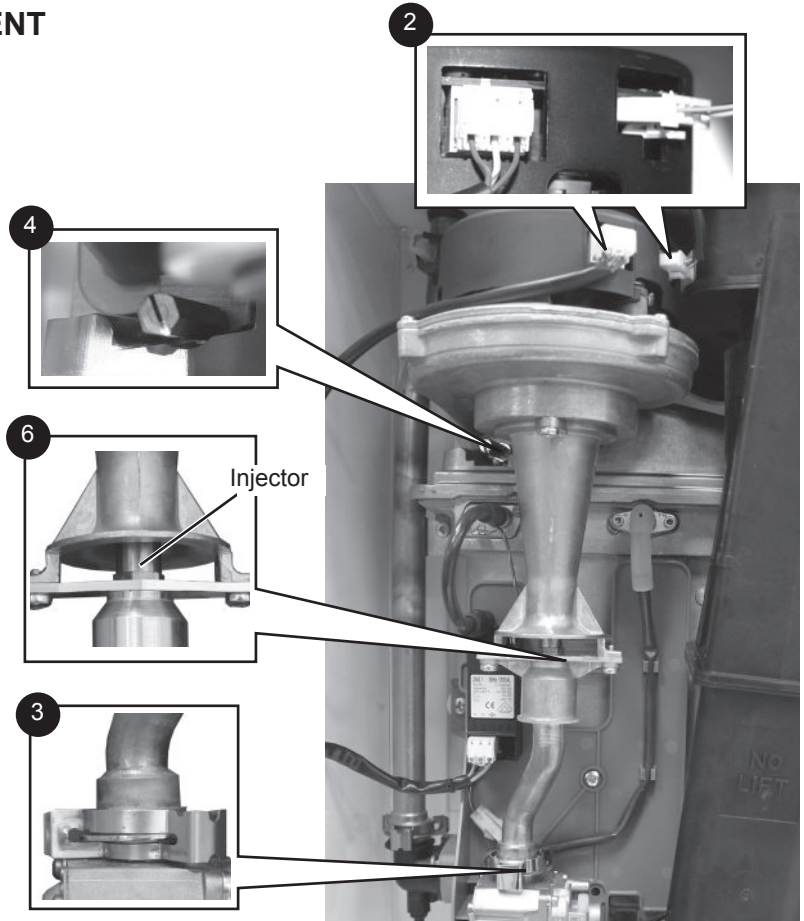

### 3.11 BURNER REPLACEMENT

1. See Section 3.4.
2. Refer to Section 3.8.
3. Undo the two screws and remove the sump cover.
4. Lift the manifold to clear the bottom sealing gasket and remove manifold.
5. Remove the 2 front fixing screws and loosen the 2 rear extended nuts.
6. Lift off the burner from the combustion chamber. To facilitate the removal angle the burner as shown.
7. Fit the new burner, replacing any damaged or deteriorating sealing gasket.
8. Reassemble in reverse order. Refer to Section 3.7.
9. Check the operation of the boiler. Refer to Sections 2.26 & 2.27.

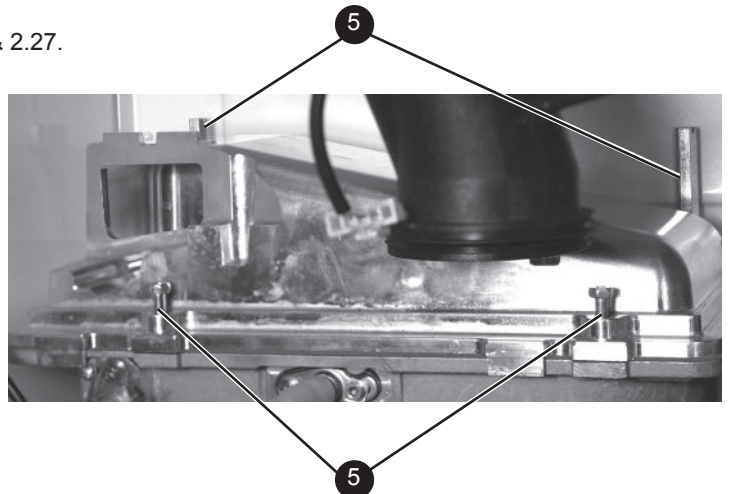
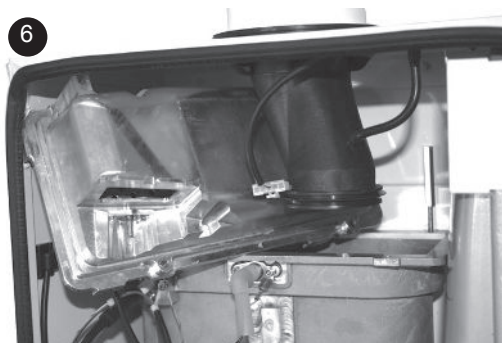
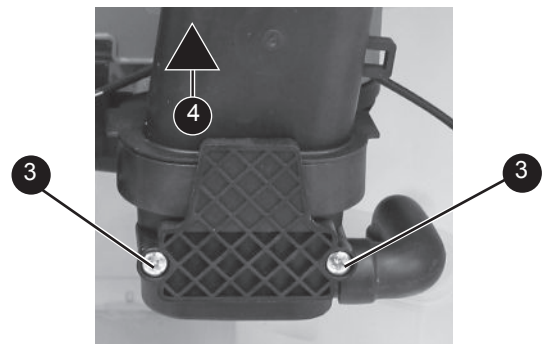

### 3.12 CONTROL & RETURN THERMISTOR REPLACEMENT

1. Refer to Section 3.8.
2. Disconnect the electrical leads from the thermistors.
3. Unclip the flow thermistor from the flow pipe and withdraw it from the boiler.
4. Unclip the return thermistor from the return pipe and withdraw it from the boiler.
5. Reconnect the electrical lead to the new thermistors and reassemble in reverse order, ensuring that the thermistor is securely fitted to the pipe on the thermistor locator tab as shown.
6. Check the operation of the boiler. Refer to Section 2.26 & 2.27.

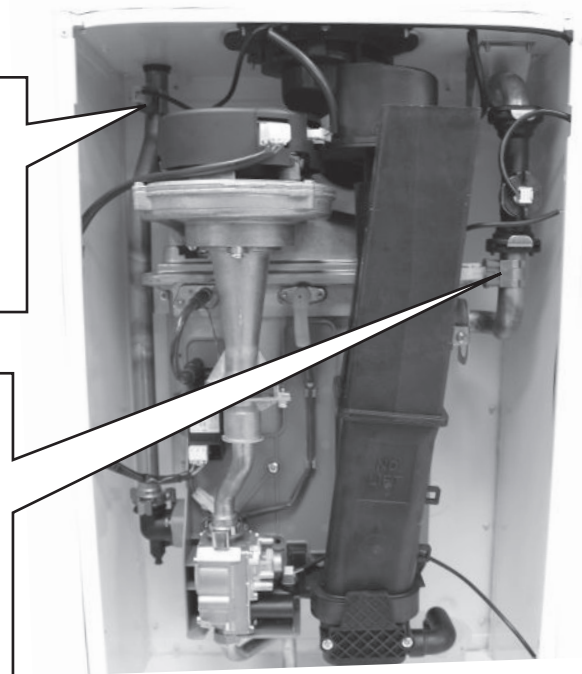
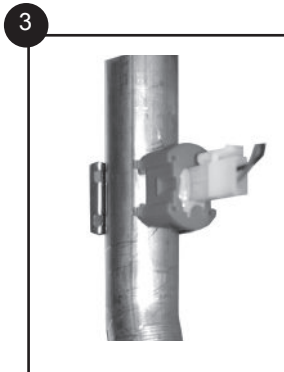
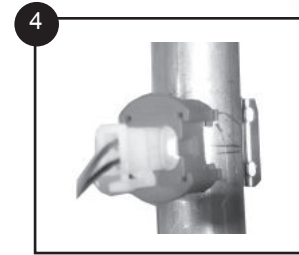
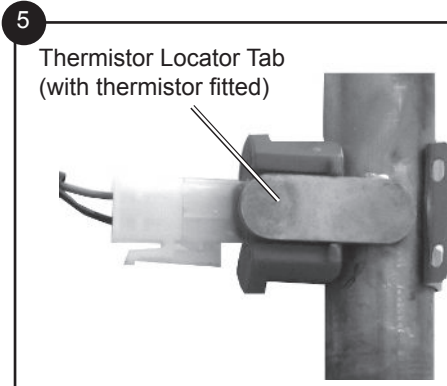

### 3.13 IGNITION ELECTRODE REPLACEMENT

1. Refer to Section 3.8.
2. Remove the burner. Refer to Section 3.11.
3. Unplug the ignition lead from the electrode.
4. Remove the earth lead from the ignition electrode.
5. Remove the 2 screws holding the ignition electrode to the combustion chamber.
6. Remove the electrode.
7. Fit the new ignition electrode, using the new gasket supplied. Check dimensions as shown.
8. Reassemble in reverse order.
9. Check the operation of the boiler. Refer to Section 2.26 & 2.27.

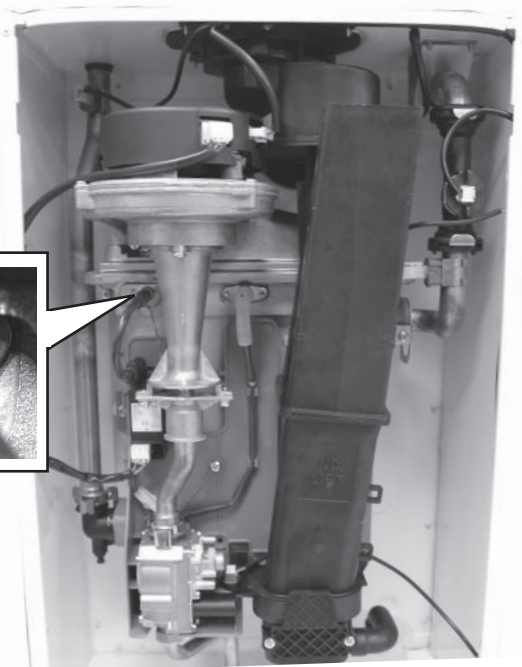
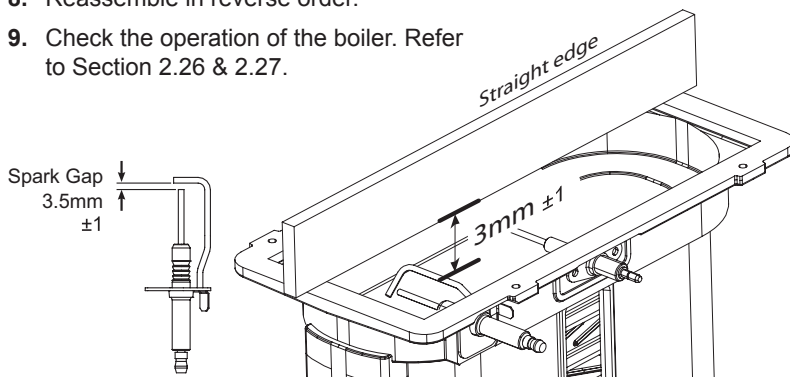
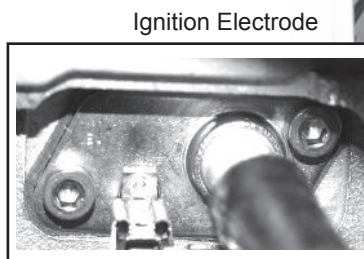

### 3.14 FLAME DETECTION ELECTRODE REPLACEMENT

1. Refer to Section 3.8.
2. Remove the burner. Refer to Section 3.11.
3. Unplug the flame detection lead from the electrode.
4. Remove the 2 screws retaining the detection electrode.
5. Remove the electrode.
6. Fit the new flame detection electrode (check dimension as shown below), using the new gasket supplied.
7. Reassemble in reverse order.
8. Check the operation of the boiler. Refer to Sections 2.26 & 2.27.

Flame Detection Electrode

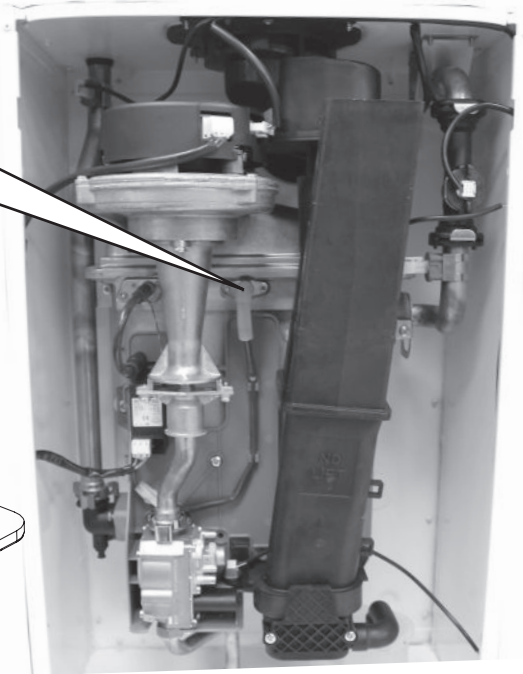
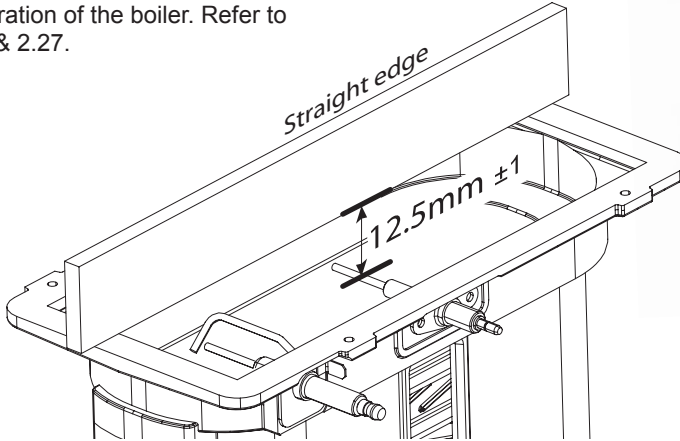
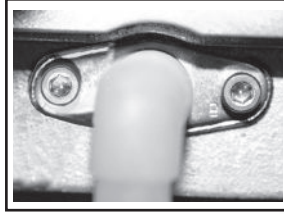

### 3.15 SPARK GENERATOR REPLACEMENT

1. Refer to Section 3.8.
2. Disconnect the leads from the spark generator
3. Gently push down the generator to release the top clip from the gas valve mounting bracket.
4. Lift the spark generator up and out of the bottom retaining moulding.
5. Fit the new spark generator and re-assemble in reverse order ensuring that the the earth lead is replaced
6. Check operation of the boiler. Refer to Sections 2.26 & 2.27.

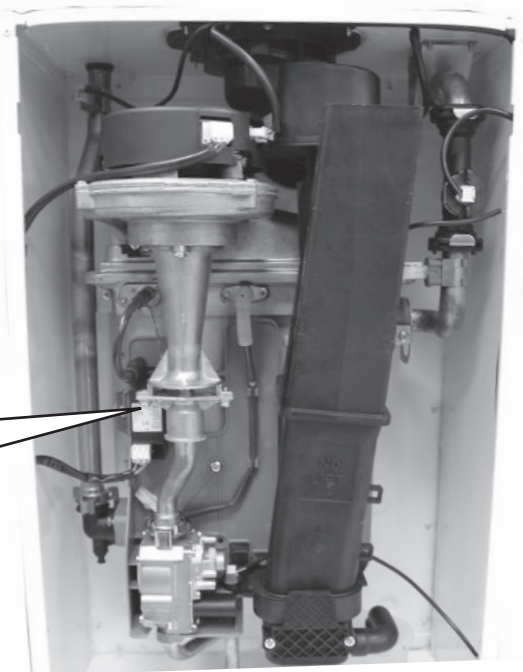
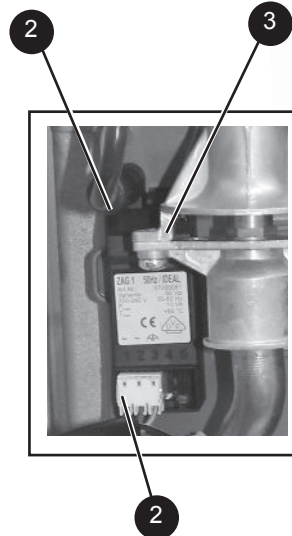

### 3.16 GAS CONTROL VALVE REPLACEMENT

1. Refer to Section 3.8.
2. Unplug the electrical lead connection from the gas control valve.
3. Remove the outlet gas valve clip and slide the pipe upwards
4. Undo the gas inlet pipe union at the inlet to the gas valve.
5. Undo the single screw fixing the gas valve to the mounting bracket and withdraw the valve forwards.
6. Fit the new gas control valve ensuring that the O ring and sealing washer are in place and reconnect gas and electrical connections.
7. Ensure all gas valve connections are gas tight with a gas soundness check up to the gas control valve.
8. Check operation of the boiler. Refer to Sections 2.26 & 2.27.

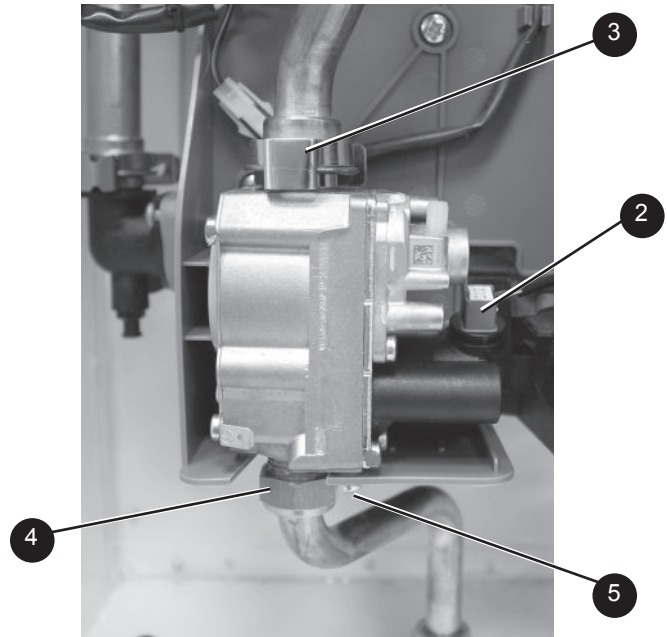

### 3.17 CONDENSATE TRAP/SIPHON REPLACEMENT

1. Refer to Section 3.8.

**Note:** Ensure condensate trap is fully drained before removal.

2. Pull off the rubber pipe at the sump drain.
3. Disconnect the condensate drain pipe.
4. Turn the siphon clockwise to disengage and lift to remove.
5. Reassemble in reverse order.
6. When reassembling ensure the trap is full of water.
7. Check operation of the boiler. Refer to Sections 2.26 & 2.27.

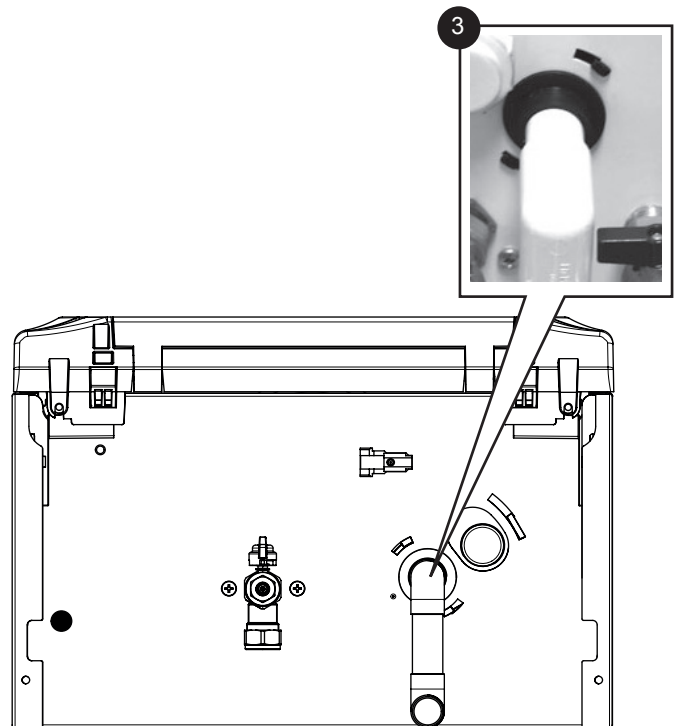
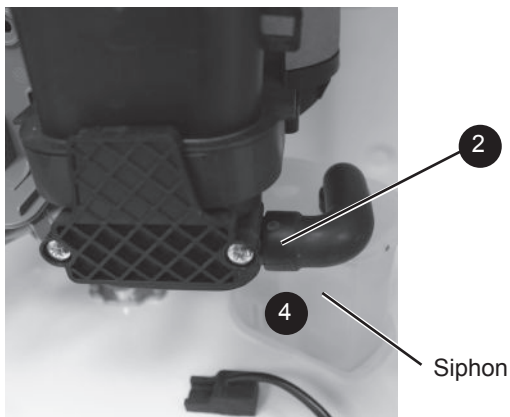

### 3.18 PCB REPLACEMENT

**Note.** Fit the earth strap provided with the PCB to your wrist and secure to a suitable earth on the boiler chassis.

1. Refer to Section 3.8.
2. Ensure the control knobs are in the 12 o'clock position.
3. Carefully release the six retaining clips and remove control box cover.
4. Unplug all lead connections to the PCB.
5. Remove the 2 screws, if applicable.
6. Spring out the four side retaining clips and pull the PCB upwards to clear the corner retaining posts.
7. Take the new PCB.
8. Re-connect all plug connections.
9. Reassemble in reverse order.
10.
  - a. Turn power on, display shows uP. Rotate both dials fully anti-clockwise.
  - b. Press RESTART, display shows of
  - c. Turn power off
  - d. Turn power on, display shows F9
  - e. Using central heating knob, rotate clockwise or anticlockwise to show "H" for Heat, then press RESTART button.
  - f. Using central heating knob, rotate clockwise or anticlockwise to show "n" for Natural Gas, then press the RESTART button.
  - g. Using central heating knob rotate clockwise or anticlockwise to show boiler size, select correct 12, 15, 18, 24 or 30, then press RESTART button.
  - h. Display shows "H", "n", Boiler size, internal number.
  - j. Press restart. New PCB is now programmed.
11. Check operation of the boiler.  
Refer to Sections 2.26 & 2.27.

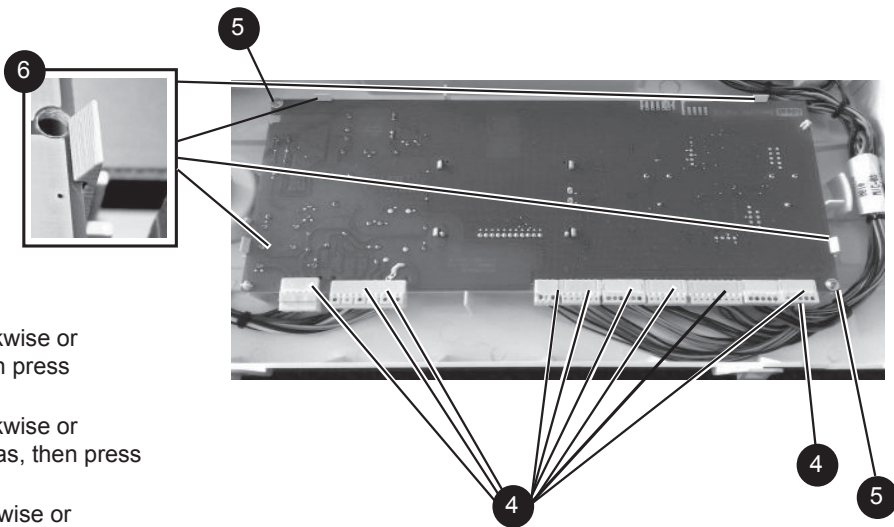
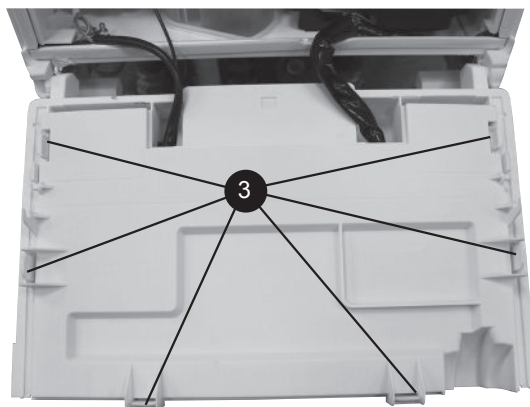

**IMPORTANT.** IT IS CRITICAL FOR SAFE OPERATION THAT THE CORRECT BOILER SIZE AND FUEL TYPE IS ENTERED INTO THE BOILER.

SERVICING

### 3.19 WATER FLOW SWITCH HEAD REPLACEMENT

1. Refer to Section 3.8.
2. Drain the Boiler. Refer to Section 3.20, item no. 2.
3. Pull off the electrical connection.
4. Turn the retaining collar anti-clockwise and pull the head from the housing.
5. Fit the new water flow switch head, ensuring the electrical lead connections wires point to the left as shown.
6. Re-assemble in reverse order.
7. Re-fill the boiler.
8. Check the operation of the boiler.  
Refer to Sections 2.26 & 2.27.

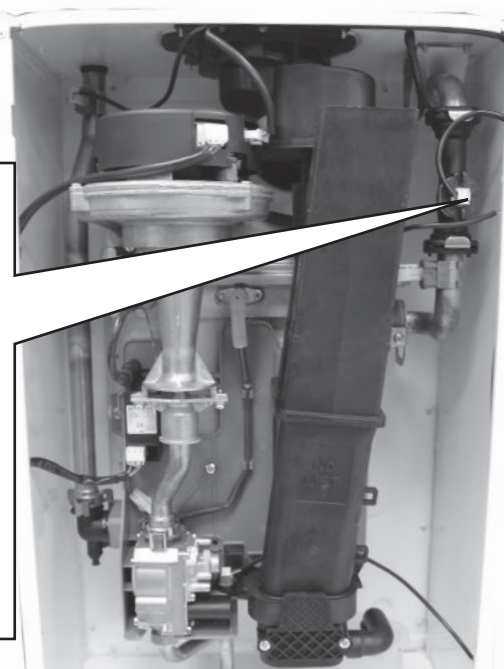
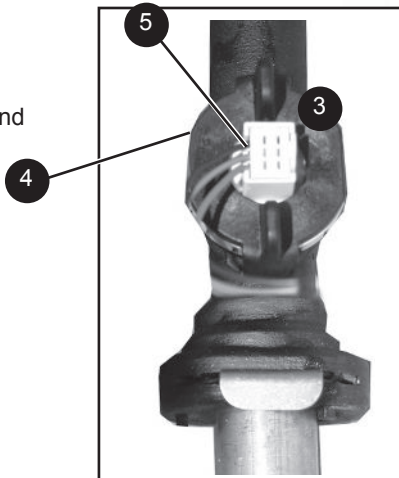

## SECTION 3 - SERVICING

### 3.20 HEAT ENGINE REPLACEMENT - Refer also to Section 2.1 - 'Boiler Exploded View'

**Note.** To remove the flow and return pipe connections from the heat exchanger, it may be necessary to cut the pipes above the boiler.

#### IMPORTANT

Before starting the removal procedure, protect the gas and electrical controls with a waterproof sheet or plastic bag.

1. Refer to Section 3.8.
2. Remove rubber plug from base to drain the boiler using the drain point.
3. Remove the fan / venturi assembly and place on one side. Refer to Section 3.9.
4. Remove the burner and place on one side. Refer to Section 3.11.
5. Remove the ignition and detection electrodes. Refer to Sections 3.13 & 3.14.
6. Remove flow and return thermistors from locations.
7. Remove the spark generator. Refer to Section 3.15.
8. Remove the gas valve. Refer to Section 3.16.
9. Remove the 2 M5 screws retaining the gas valve mounting bracket and transfer bracket to the new heat exchanger.
10. Pull the clips, retaining the water flow switch housing, forward and remove the water flow switch.
11. Remove the screw securing the pipe to the heat exchanger and remove the "c" clip. Lift the housing/return pipe assembly upwards to disengage from the heat exchanger return pipe elbow.
12. Remove the screw retaining the flow pipe bracket and remove the bracket from its rear retention slot.
13. Pull the flow pipe to the right to disengage from the heat exchanger.
14. Remove the condensate rubber pipe. Refer to Section 3.17.
15. Remove the LH heat exchanger fixing screw.
16. Pull the heat exchanger to the left to disengage the rear retention pegs and remove the heat exchanger.
17. If replacement sump required: Rotate heat exchanger assembly 180°. Place new sump onto heat exchanger, ensuring correct orientation and seal is in place. Then gently apply pressure to the base of the sump at each tab fixing point and engage tabs onto the heat exchanger.
18. Reassemble in reverse order, ensuring the heat exchanger is correctly positioned. Replace any new 'o' rings supplied with new heat exchanger and replacing gaskets or seals if any sign of damage is evident. Note. Ensure that the flow pipe is fitted through the "V" bracket when refitting.
19. Ensure the trap/siphon is filled with water. Refer to Section 3.17.
20. Refill the boiler, ensuring rubber plug from base is re-fitted, and drain point is fully closed.
21. Ensure all gas valve connections are gas tight with a gas soundness check up to the gas control valve.
22. Check operation of the boiler. Refer to Sections 2.26 & 2.27.

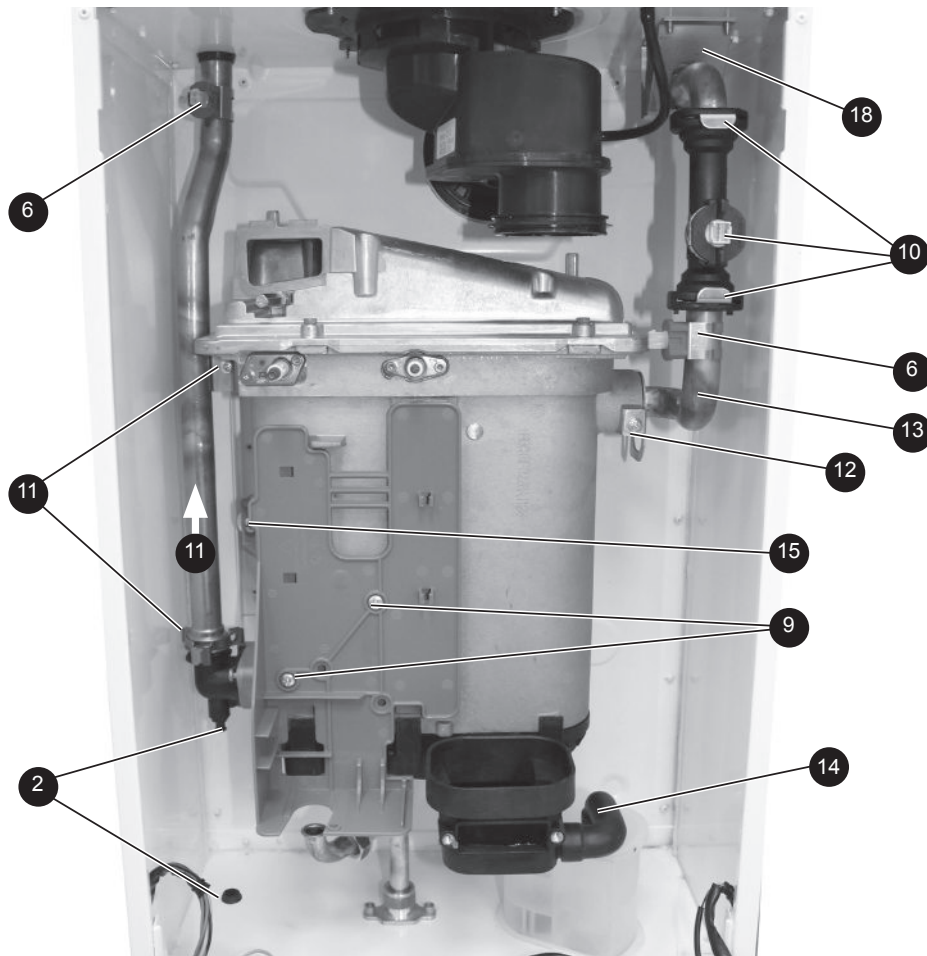

Shown as 180° position

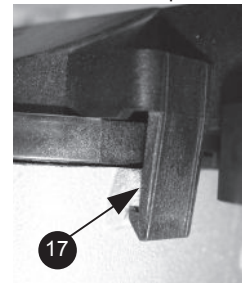

## SECTION 4 - FAULT FINDING

### 4.1 FAULT FINDING CHART MAIN MENU

In order to assist fault finding the boiler has a 7 segment display. The key to the display codes is as follows:

'L1'	GO TO SECTION 4.2 - FLOW TEMPERATURE OVERHEAT LOCKOUT or NO WATER FLOW LOCKOUT
'L2'	GO TO SECTION 4.3 - IGNITION LOCKOUT
'LC'	5 RESTARTS WITHIN 15 MINS - TURN POWER OFF AND ON
'L6'	GO TO SECTION 4.4 - FALSE FLAME LOCKOUT
'L7'	<5°C RISE ON 3 SUCCESSIVE OCCASIONS. CHECK THERMISTORS ARE CLIPPED ONTO PIPES Note: burner will be switched off for 2 mins between attempts. Function inactive if temperature is >40°C.
'FA'	GO TO SECTION 4.5 - FLOW / RETURN REVERSED
'Fd'	GO TO SECTION 4.6 - NO WATER FLOW
'F2' or 'Fn' or 'Ln'	GO TO SECTION 4.7 - FLAME LOSS
'F3'	GO TO SECTION 4.8 - FAN FAULT
'L4' or 'F4'	GO TO SECTION 4.9 - CONTROL/NO FLOW THERMISTOR FAULT
'L5' or 'F5'	GO TO SECTION 4.10 - RETURN THERMISTOR FAULT
'F6'	GO TO SECTION 4.11 - OUTSIDE SENSOR FAULT
'F7'	LOW MAINS VOLTAGE - CONTACT ELECTRICITY PROVIDER
'F9' or 'L9' or 'F8' or 'L8'	PCB UNCONFIGURED/FAULTY OR GAS VALVE SHORT CIRCUIT. SEE SECTION 3.18. IF FAULT PERSISTS REPLACE PCB
'FU'	DIFF GREATER THAN 50°C. CHECK ISOLATION VALVES ARE OPEN, CHECK PUMP, CHECK RAD VALVES OPEN, CHECK SYSTEM BLOCKAGES.
NO CH	GO TO SECTION 4.12
NO HW	GO TO SECTION 4.14
NO DISPLAY	GO TO SECTION 4.13

**RESTART PROCEDURE** - To restart boiler, press the "RESTART" button.

## SECTION 4 - FAULT FINDING

### 4.2 'L1' - FLOW TEMPERATURE OVERHEAT LOCKOUT OR NO WATER FLOW LOCKOUT

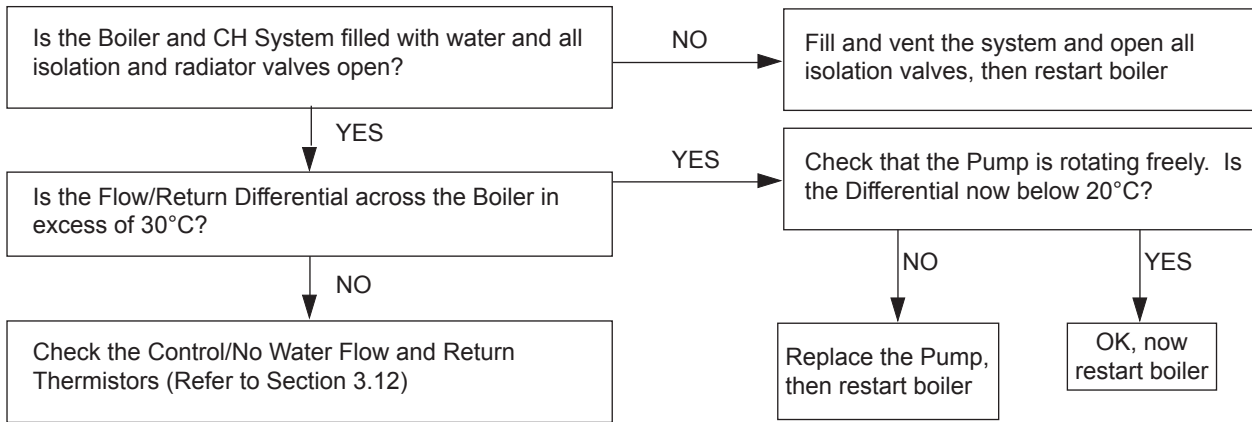

**RESTART PROCEDURE** - To restart boiler, press the "RESTART" button.

### 4.3 'L2' - IGNITION LOCKOUT

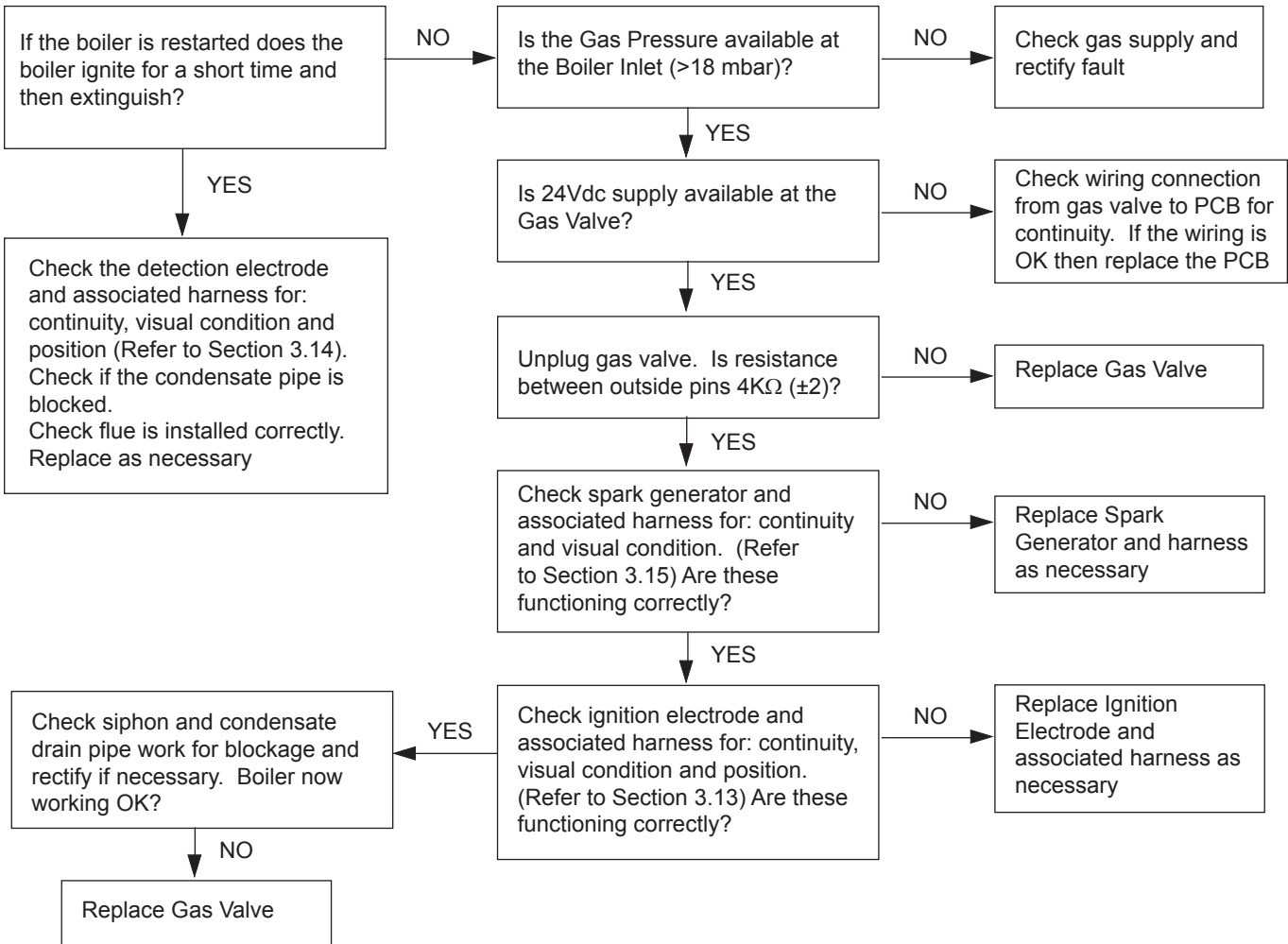

**RESTART PROCEDURE** - To restart boiler, press the RESTART button.

## SECTION 4 - FAULT FINDING

### 4.4 'L6' - FALSE FLAME LOCKOUT

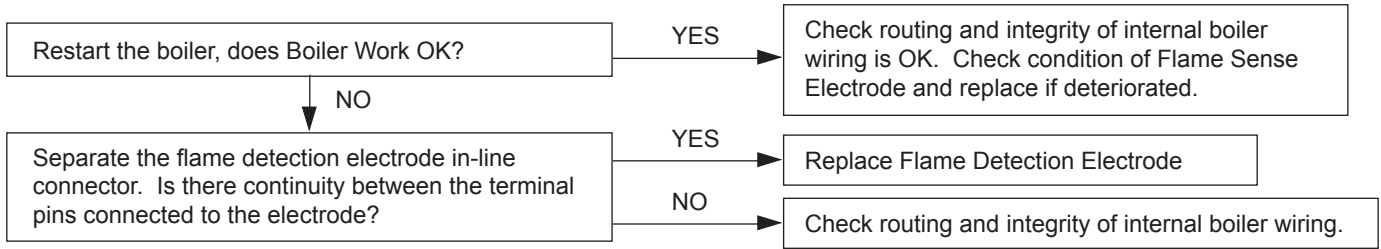

**RESTART PROCEDURE** - To restart boiler, press the "RESTART" button.

### 4.5 'FA' - FLOW / RETURN REVERSED

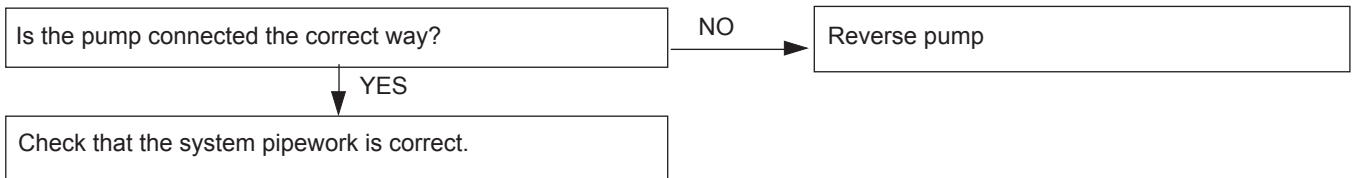

### 4.6 'Fd' - NO WATER FLOW

**Note** - 'Fd' will only be shown if no water flow is detected for 60 secs and the temperature is less than 40°C.

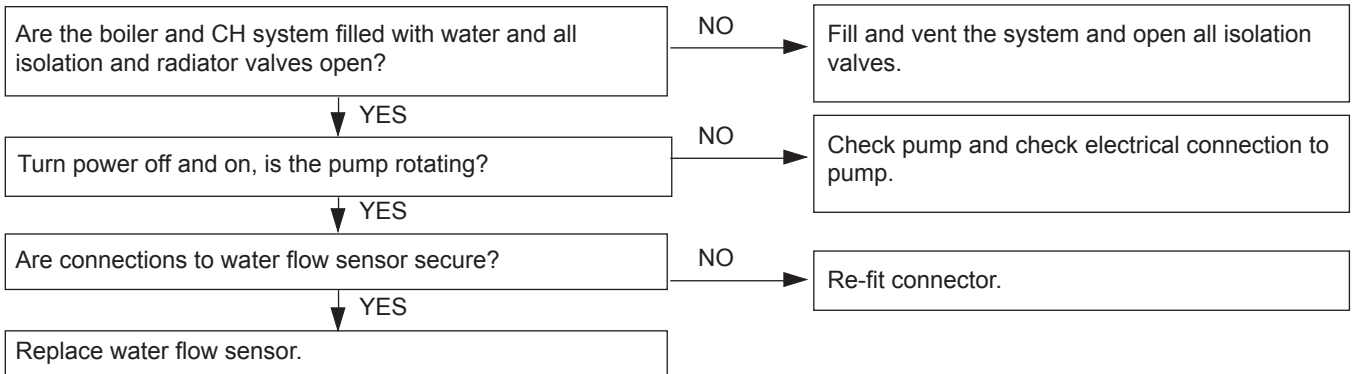

### 4.7 'F2' OR 'Fn' OR 'Ln' - FLAME LOSS

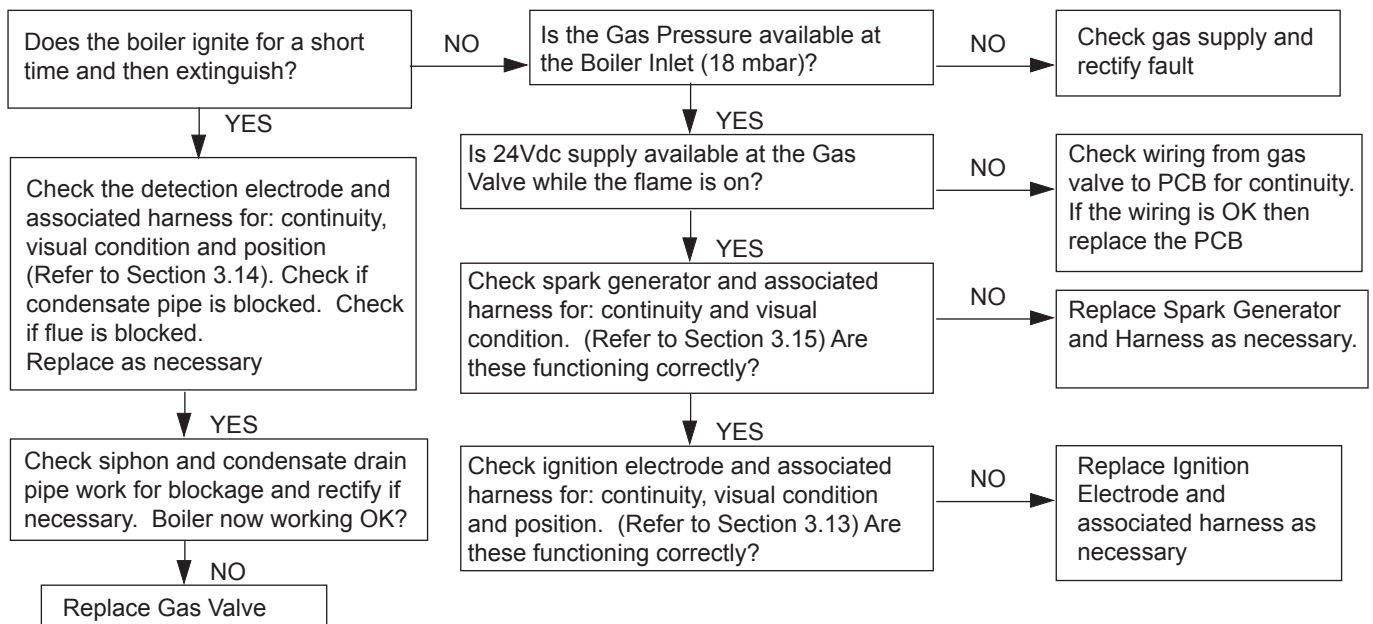

## SECTION 4 - FAULT FINDING

### 4.8 'F3' - FAN FAULT

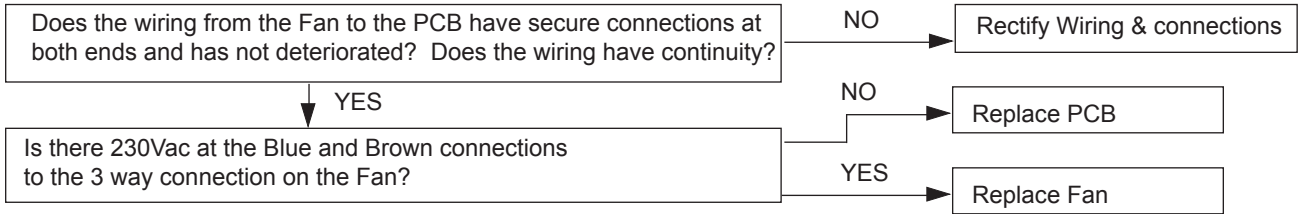

### 4.9 'L4' OR 'F4' - CONTROL / NO FLOW THERMISTOR FAULT

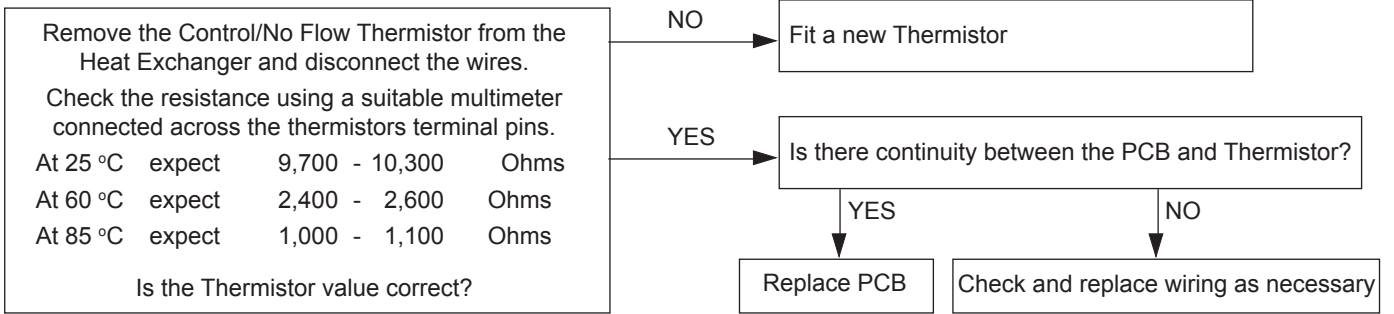

### 4.10 'F5 OR L5' - RETURN THERMISTOR FAULT

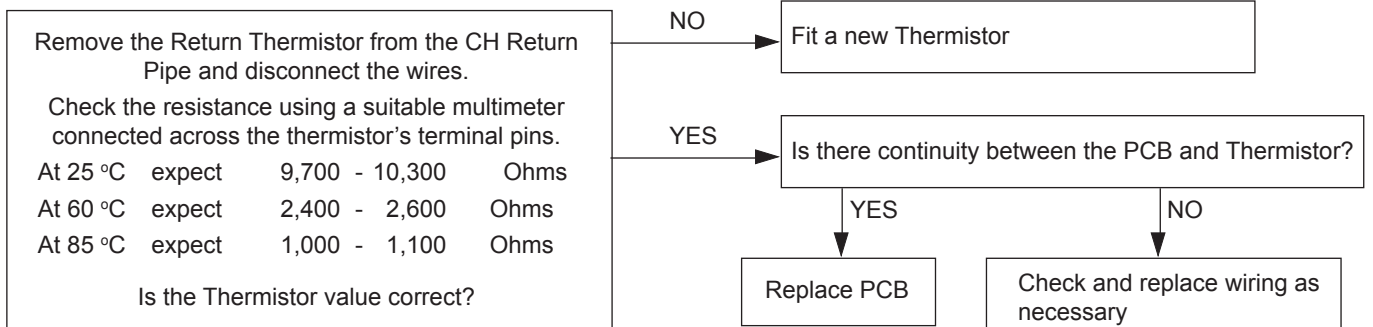

### 4.11 'F6' - OUTSIDE SENSOR FAULT

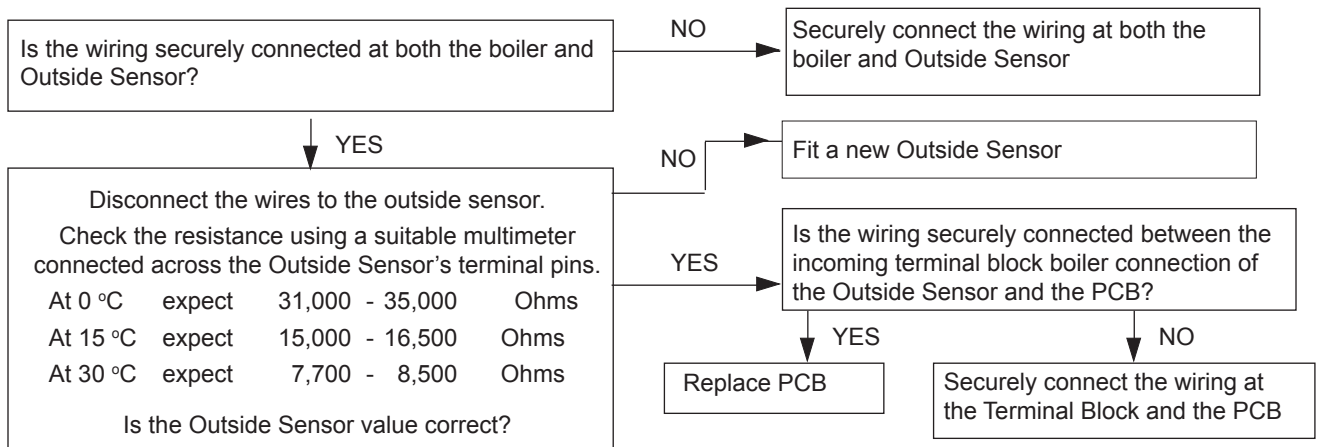

## SECTION 4 - FAULT FINDING

### 4.12 NO CH OPERATION

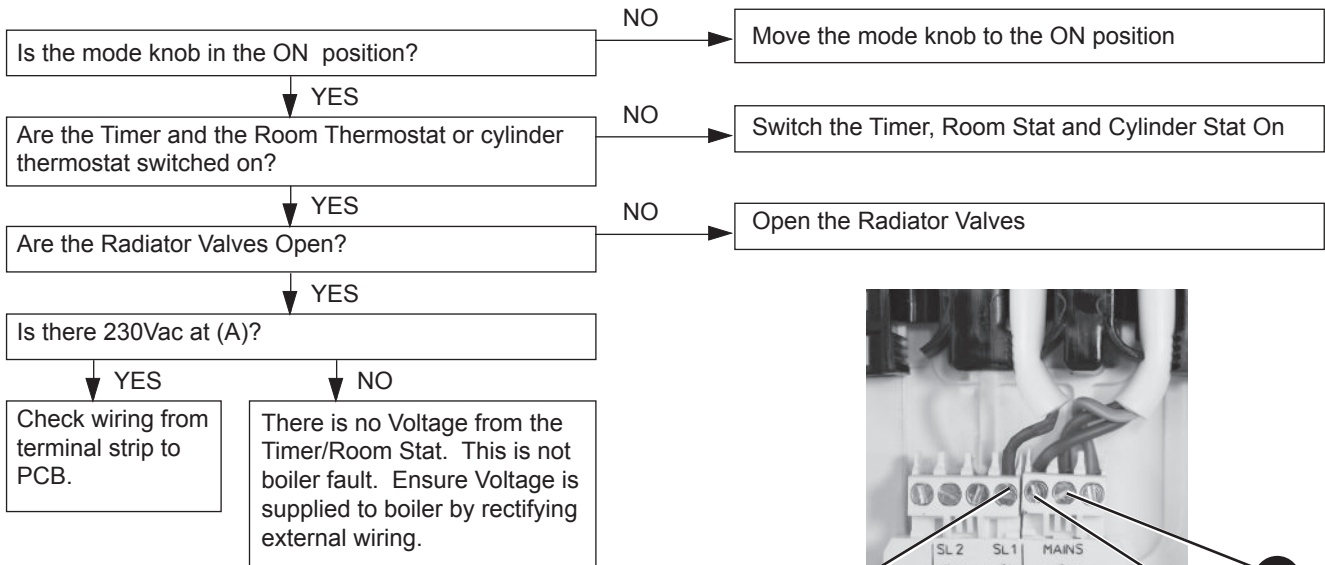

### 4.13 NO DISPLAY

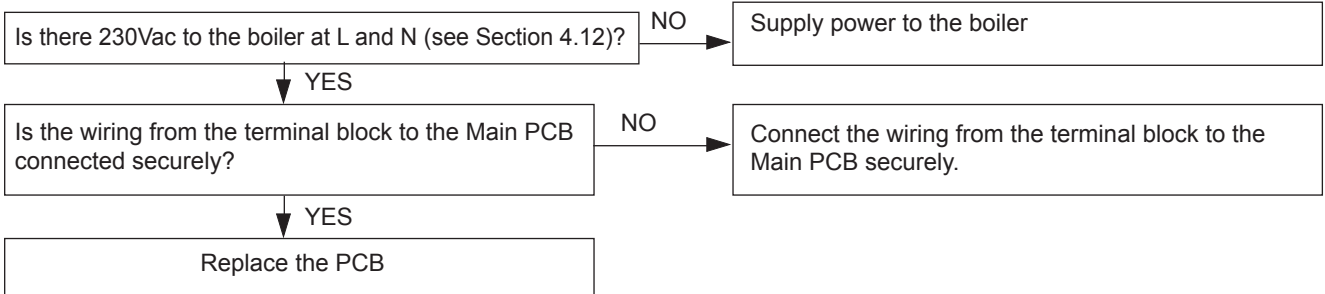

### 4.14 NO DHW

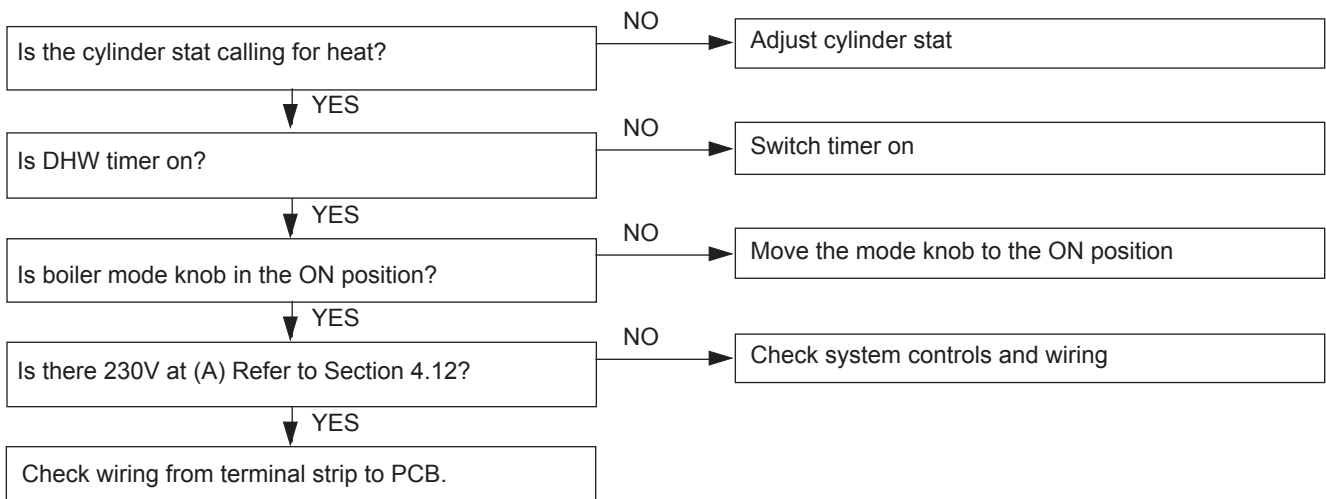

## SECTION 5 - SPARE PARTS

---

When replacing any part on this appliance use only spare parts that you can be assured conform to the safety and performance specification that we require. Do not use reconditioned or copy parts that have not been clearly authorised by Ideal. Failure to do so could affect safety or performance of this appliance.

Comprehensive spare parts information and details of approved Ideal Parts Distributors are available on [www.idealparts.com](http://www.idealparts.com)

**Our Parts team are also available to help with your Ideal Spare Parts enquiries on 01482 498665.**

When calling, and to ensure we can provide you with the most accurate parts information, please ensure you have the following to hand;

- Boiler Model
- Appliance GC Number
- Boiler Serial Number

### **IMPORTANT NOTE.**

**Propane Boilers** - After installation of a conversion kit, and when ordering future spares be sure to quote the serial letter code AAV - which indicates a Propane boiler - and the boilers original serial letter code from the original data plate.

# Code Of Practice

For the installation, commissioning and servicing  
of domestic heating and hot water products

Benchmark places responsibilities on both manufacturers and installers.\* The purpose is to ensure that customers\*\* are provided with the correct equipment for their needs, that it is installed, commissioned and serviced in accordance with the manufacturer's instructions by competent persons and that it meets the requirements of the appropriate Building Regulations. Installers are required to carry out work in accordance with the following:

## Standards of Work

- Be competent and qualified to undertake the work required.
- Install, commission, service and use products in accordance with the manufacturer's instructions provided.
- Ensure that where there is responsibility for design work, the installation is correctly sized and fit for purpose.
- Meet the requirements of the appropriate Building Regulations. Where this involves notifiable work be a member of a Competent Persons Scheme or confirm that the customer has notified Local Authority Building Control (LABC), prior to work commencing.
- Complete all relevant sections of the Benchmark Checklist/Service Record when carrying out commissioning or servicing of a product or system.
- Ensure that the product or system is left in a safe condition and, whenever possible, in good working order.
- Highlight to the customer any remedial or improvement work identified during the course of commissioning or servicing work.
- Refer to the manufacturer's helpline where assistance is needed.
- Report product faults and concerns to the manufacturer in a timely manner.

## Customer Service

- Show the customer any identity card that is relevant to the work being carried out prior to commencement or on request.
- Give a full and clear explanation/demonstration of the product or system and its operation to the customer.
- Hand over the manufacturer's instructions, including the Benchmark Checklist, to the customer on completion of an installation.
- Obtain the customer's signature, on the Benchmark Checklist, to confirm satisfactory demonstration and receipt of manufacturer's instructions.
- Advise the customer that regular product servicing is needed, in line with manufacturers' recommendations, to ensure that safety and efficiency is maintained.
- Respond promptly to calls from a customer following completion of work, providing advice and assistance by phone and, if necessary, visiting the customer.
- Rectify any installation problems at no cost to the customer during the installer's guarantee period.



\*The use of the word "installer" is not limited to installation itself and covers those carrying out installation, commissioning and/or servicing of heating and hot water products, or the use of supporting products (such as water treatment or test equipment).

\*\*Customer includes householders, landlords and tenants.

# Benchmark Commissioning and Servicing Section

It is a requirement that the boiler is installed and commissioned to the manufacturers instructions and the data fields on the commissioning checklist completed in full.

To instigate the boiler guarantee the boiler needs to be registered with the manufacturer within one month of the installation.

To maintain the boiler guarantee it is essential that the boiler is serviced annually by a Gas Safe registered engineer who has been trained on the boiler installed. The service details should be recorded on the Benchmark Service Interval Record and left with the householder.



[www.centralheating.co.uk](http://www.centralheating.co.uk)

© Heating and Hotwater Industry Council (HHIC)

# GAS BOILER SYSTEM COMMISSIONING CHECKLIST

This Commissioning Checklist is to be completed in full by the competent person who commissioned the boiler as a means of demonstrating compliance with the appropriate Building Regulations and then handed to the customer to keep for future reference.

Failure to install and commission according to the manufacturer's instructions and complete this Benchmark Commissioning Checklist will invalidate the warranty. This does not affect the customer's statutory rights.

Customer name:	Telephone number:
Address:	
Boiler make and model:	
Boiler serial number:	
Commissioned by (PRINT NAME):	Gas Safe register number:
Company name:	Telephone number:
Company address:	
	Commissioning date:

**To be completed by the customer on receipt of a Building Regulations Compliance Certificate\***

Building Regulations Notification Number (if applicable):

CONTROLS (tick the appropriate boxes)			
Time and temperature control to heating	Room thermostat and programmer/timer	<input type="checkbox"/>	Programmable room thermostat
	Load/weather compensation	<input type="checkbox"/>	Optimum start control
Time and temperature control to hot water	Cylinder thermostat and programmer/timer	<input type="checkbox"/>	Combination Boiler
Heating zone valves	Fitted	<input type="checkbox"/>	Not required
Hot water zone valves	Fitted	<input type="checkbox"/>	Not required
Thermostatic radiator valves	Fitted	<input type="checkbox"/>	Not required
Automatic bypass to system	Fitted	<input type="checkbox"/>	Not required
Boiler interlock		<input type="checkbox"/>	Provided

ALL SYSTEMS			
The system has been flushed and cleaned in accordance with BS7593 and boiler manufacturer's instructions		Yes	<input type="checkbox"/>
What system cleaner was used?			
What inhibitor was used?	Quantity	litres	
Has a primary water system filter been installed?	Yes	<input type="checkbox"/>	No <input type="checkbox"/>

CENTRAL HEATING MODE measure and record:			
Gas rate	m <sup>3</sup> /hr	OR	ft <sup>3</sup> /hr
Burner operating pressure (if applicable)	mbar	OR Gas inlet pressure	mbar
Central heating flow temperature			°C
Central heating return temperature			°C

COMBINATION BOILERS ONLY			
Is the installation in a hard water area (above 200ppm)?	Yes	<input type="checkbox"/>	No <input type="checkbox"/>
If yes, and if required by the manufacturer, has a water scale reducer been fitted?	Yes	<input type="checkbox"/>	No <input type="checkbox"/>
What type of scale reducer has been fitted?			

DOMESTIC HOT WATER MODE Measure and Record:			
Gas rate	m <sup>3</sup> /hr	OR	ft <sup>3</sup> /hr
Burner operating pressure (at maximum rate)	mbar	OR Gas inlet pressure at maximum rate	mbar
Cold water inlet temperature			°C
Hot water has been checked at all outlets	Yes	<input type="checkbox"/>	Temperature °C <input type="checkbox"/>
Water flow rate			l/min

CONDENSING BOILERS ONLY			
The condensate drain has been installed in accordance with the manufacturer's instructions and/or BS5546/BS6798		Yes	<input type="checkbox"/>

ALL INSTALLATIONS					
Record the following:	At max. rate:	CO	ppm	AND	CO/CO <sub>2</sub> Ratio
	At min. rate: (where possible)	CO	ppm	AND	CO/CO <sub>2</sub> Ratio
The heating and hot water system complies with the appropriate Building Regulations					Yes <input type="checkbox"/>
The boiler and associated products have been installed and commissioned in accordance with the manufacturer's instructions					Yes <input type="checkbox"/>
The operation of the boiler and system controls have been demonstrated to and understood by the customer					Yes <input type="checkbox"/>
The manufacturer's literature, including Benchmark Checklist and Service Record, has been explained and left with the customer					Yes <input type="checkbox"/>

Commissioning Engineer's Signature
Customer's Signature
(To confirm satisfactory demonstration and receipt of manufacturer's literature)

\* All installations in England and Wales must be notified to Local Authority Building Control (LABC) either directly or through a Competent Persons Scheme. A Building Regulations Compliance Certificate will then be issued to the customer.



# SERVICE RECORD

It is recommended that your heating system is serviced regularly and that the appropriate Service Interval Record is completed.

## Service Provider

Before completing the appropriate Service Record below, please ensure you have carried out the service as described in the manufacturer's instructions. Always use the manufacturer's specified spare part when replacing controls.

<b>SERVICE 01</b>					Date:
Engineer name:					
Company name:					
Telephone No:					
Gas safe register No:					
Record:	At max. rate:	CO	ppm	<b>AND</b>	CO <sub>2</sub> %
	At min. rate: (Where Possible)	CO	ppm	<b>AND</b>	CO <sub>2</sub> %
Comments:					
Signature					

<b>SERVICE 02</b>					Date:
Engineer name:					
Company name:					
Telephone No:					
Gas safe register No:					
Record:	At max. rate:	CO	ppm	<b>AND</b>	CO <sub>2</sub> %
	At min. rate: (Where Possible)	CO	ppm	<b>AND</b>	CO <sub>2</sub> %
Comments:					
Signature					

<b>SERVICE 03</b>					Date:
Engineer name:					
Company name:					
Telephone No:					
Gas safe register No:					
Record:	At max. rate:	CO	ppm	<b>AND</b>	CO <sub>2</sub> %
	At min. rate: (Where Possible)	CO	ppm	<b>AND</b>	CO <sub>2</sub> %
Comments:					
Signature					

<b>SERVICE 04</b>					Date:
Engineer name:					
Company name:					
Telephone No:					
Gas safe register No:					
Record:	At max. rate:	CO	ppm	<b>AND</b>	CO <sub>2</sub> %
	At min. rate: (Where Possible)	CO	ppm	<b>AND</b>	CO <sub>2</sub> %
Comments:					
Signature					

<b>SERVICE 05</b>					Date:
Engineer name:					
Company name:					
Telephone No:					
Gas safe register No:					
Record:	At max. rate:	CO	ppm	<b>AND</b>	CO <sub>2</sub> %
	At min. rate: (Where Possible)	CO	ppm	<b>AND</b>	CO <sub>2</sub> %
Comments:					
Signature					

<b>SERVICE 06</b>					Date:
Engineer name:					
Company name:					
Telephone No:					
Gas safe register No:					
Record:	At max. rate:	CO	ppm	<b>AND</b>	CO <sub>2</sub> %
	At min. rate: (Where Possible)	CO	ppm	<b>AND</b>	CO <sub>2</sub> %
Comments:					
Signature					

<b>SERVICE 07</b>					Date:
Engineer name:					
Company name:					
Telephone No:					
Gas safe register No:					
Record:	At max. rate:	CO	ppm	<b>AND</b>	CO <sub>2</sub> %
	At min. rate: (Where Possible)	CO	ppm	<b>AND</b>	CO <sub>2</sub> %
Comments:					
Signature					

<b>SERVICE 08</b>					Date:
Engineer name:					
Company name:					
Telephone No:					
Gas safe register No:					
Record:	At max. rate:	CO	ppm	<b>AND</b>	CO <sub>2</sub> %
	At min. rate: (Where Possible)	CO	ppm	<b>AND</b>	CO <sub>2</sub> %
Comments:					
Signature					

<b>SERVICE 09</b>					Date:
Engineer name:					
Company name:					
Telephone No:					
Gas safe register No:					
Record:	At max. rate:	CO	ppm	<b>AND</b>	CO <sub>2</sub> %
	At min. rate: (Where Possible)	CO	ppm	<b>AND</b>	CO <sub>2</sub> %
Comments:					
Signature					

<b>SERVICE 10</b>					Date:
Engineer name:					
Company name:					
Telephone No:					
Gas safe register No:					
Record:	At max. rate:	CO	ppm	<b>AND</b>	CO <sub>2</sub> %
	At min. rate: (Where Possible)	CO	ppm	<b>AND</b>	CO <sub>2</sub> %
Comments:					
Signature					

\* All installations in England and Wales must be notified to Local Authority Building Control (LABC) either directly or through a Competent Persons Scheme. A Building Regulations Compliance Certificate will then be issued to the customer.



# FLOWCHART FOR CO LEVEL AND COMBUSTION RATIO CHECK ON COMMISSIONING A CONDENSING BOILER

## Important Preliminary Information on Checks

The air gas ratio valve is factory-set and must not be adjusted DURING COMMISSIONING.

If the boiler requires conversion to operate with a different gas family (e.g. conversion from natural gas to LPG) separate guidance is provided with the conversion kit supplied and this must be followed.

### PRIOR TO CO LEVEL AND COMBUSTION RATIO CHECK

The installation instructions must have been followed, gas type verified and gas supply pressure / gas rate checked as required prior to commissioning.

As part of the installation process, ESPECIALLY WHERE A FLUE HAS BEEN FITTED BY PERSONS OTHER THAN THE BOILER INSTALLER, visually check the integrity of the whole flue system to confirm that all components are correctly assembled, fixed and supported. Check that maximum flue lengths have not been exceeded and all guidance has been followed (e.g. Gas Safe Register Technical Bulletin (TB) 008 where chimney/flues are in voids).

The ECGA should be of the correct type, as specified by BS 7967.

Prior to its use, the ECGA should have been maintained and calibrated as specified by the manufacturer. The installer must have the relevant competence for use of the analyser.

Check and zero the analyser IN FRESH AIR in accordance with the analyser manufacturer's instructions.

KEY:

**CO** = carbon monoxide

**CO<sub>2</sub>** = carbon dioxide

**O<sub>2</sub>** = oxygen

**Combustion Ratio** = The CO reading measured in ppm divided by the CO<sub>2</sub> reading first converted to ppm

**ppm** = parts per million

**GS(I&U)R** = Gas Safety (Installation and Use) Regulations

**IMPORTANT:** Ensure boiler is in normal operation with a heat demand before setting Maximum / Minimum rate function.

#### Setting to Maximum Rate:

1. Hold "RESTART" & Function buttons together for more than 5s
2. Last 3 faults will be shown
3. SL shown, press the Function button
4. SH shown, press "RESTART"
5. Burner will run for 10 minutes at maximum rate.
6. Press "RESTART" to exit Maximum rate mode.

#### \*Setting to Minimum Rate:

1. Hold "RESTART" & Function buttons together for more than 5s
2. Last 3 faults will be shown
3. SL shown, press "RESTART"
4. Burner will run for 10 minutes at minimum rate.
5. Press "RESTART" to exit Minimum rate mode.

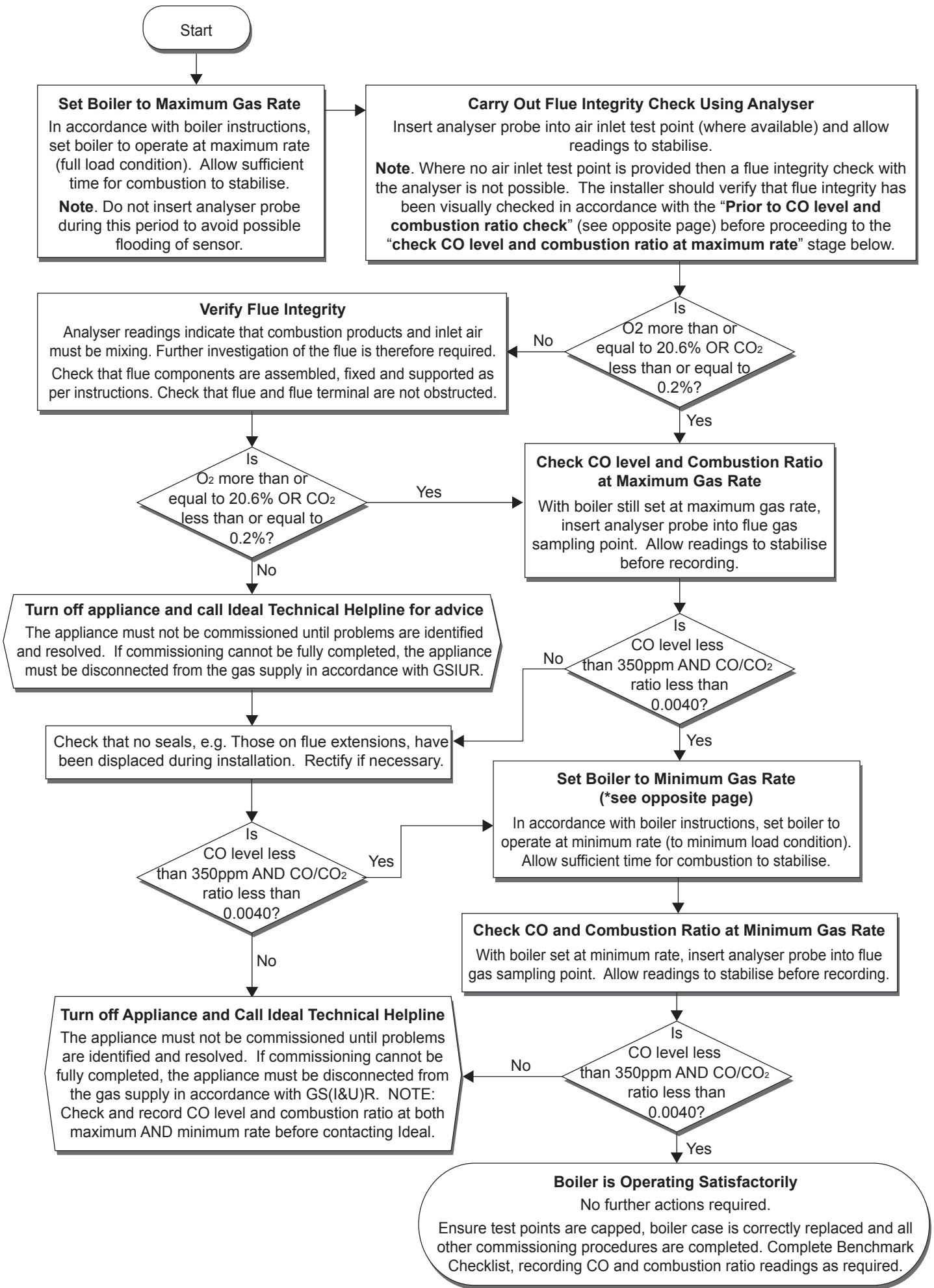

## NOTES

## NOTES

## NOTES

## NOTES



*The code of practice for the installation,  
commissioning & servicing of central heating systems*



FM 59915

Manufactured under an ISO 9001  
registered quality management system

### **Technical Training**

The Ideal Technical Training Centre offers a series of first class training courses for domestic, commercial and industrial heating installers, engineers and system specifiers.

For details of courses please ring:..... 01482 498432

Ideal Boilers Ltd. pursues a policy of continuing improvement in the design and performance of its products.  
The right is therefore reserved to vary specification without notice.

Ideal Boilers Ltd., PO Box 103, National Avenue, Kingston Upon Hull, HU5 4JN

Tel 01482 492251 Fax 01482 448858

Registration No. London 322 137

Ideal Technical Helpline: 01482 498663  
Ideal Consumer Helpline: 01482 498660  
[www.idealboilers.com](http://www.idealboilers.com)