

# INSTALLATION AND SERVICING

## LOGIC Heat 12, 15, 18, 24, 30

For users guide see reverse of book



For details of document amendments, refer to page 3

When replacing any part on this appliance, use only spare parts that you can be assured conform to the safety and performance specification that we require. Do not use reconditioned or copy parts that have not been clearly authorised by Ideal.

For the very latest copy of literature for specification and maintenance practices visit our website [www.idealboilers.com](http://www.idealboilers.com) where you can download the relevant information in PDF format.

January 2014  
UIN 205862 A06





## NOTES FOR THE INSTALLER

**FOR ANY TECHNICAL QUERIES PLEASE RING THE  
IDEAL INSTALLER HELPLINE : 01482 498704**

**NOTE. BOILER RESET PROCEDURE -**

To reset boiler, turn mode knob to reset position and immediately turn knob back to required setting.  
The boiler will repeat the ignition sequence if a heat demand is present.

## DOCUMENT AMENDMENTS

Relevant Installation changes implemented in this book from Mod Level ..... A05 (Jul 2013) to A06 (Jan 2014)

---

**page 35**

Statement added ref to commissioning process of combustion

**page 57**

New Page Added - Benchmark Commissioning & Servicing Section

**page 58 & 59**

New updated Commissioning Checklist & Service Record Sheets

**page 60 & 61**

New pages added, Flowchart for CO Level and Combustion Ratio Check on Commissioning a Condensing Boiler

# gENERaL

**Table 1 - general Data**

Ideal Logic heat		12	15	18	24	30
Gas supply		2H - G20 - 20mbar				
Gas Supply Connection		15mm copper compression				
Injector Size	(mm)	4.15	4.15	4.15	4.15	4.65
Flow Connection	Central Heating	22mm copper compression				
Return Connection	Central Heating	22mm copper compression				
Flue Terminal Diameter - Turret	mm (in)	100 (4)				
Flue Terminal Diameter - Rear Flue Outlet (55/80)	mm (in)	80 (3)				
Average Flue Temp-Mass Flow Rate	56°C - 5g/s	56°C - 5g/s	56°C - 6g/s	58°C - 8g/s	63°C - 10g/s	69°C - 13g/s
Max. static water head	m (ft.)	30.5 (100)				
Min. static water head	m (ft.)	0.45 (1.5)				
Max. Working Pressure (Sealed Systems)	bar (lb/in <sup>2</sup> )	2.5 (36.3)				
Electrical Supply		230 V ~ 50 Hz.				
Power Consumption	W	23	26	31	46	48
Fuse Rating		External : 3A Internal : T4H HRC L250 V				
Water content	litre (gal)	1.2 (0.26)				
Packaged Weight	kg (lb)	28.7 (63.3)	28.7 (63.3)	28.7 (63.3)	28.7 (63.3)	28.7 (63.3)
Maximum Installation Weight	kg (lb)	23 (51)	23 (51)	23 (51)	23 (51)	23 (51)
Boiler Casing Size	Height	700 (27.5)				
	Width	395 (15.5)				
	Depth	278 (11)				

**Table 2 - performance Data - Central heating**

		12		15		18		24		30		
		MIN	MAX	MIN	MAX	MIN	MAX	MIN	MAX	MIN	MAX	
Boiler Input :												
Boiler Input 'Q'	Nett CV	kW	4.9	12.1	4.9	15.1	4.9	18.1	4.9	24.3	6.1	30.4
		(Btu/h)	(16,600)	(41,300)	(16,600)	(51,520)	(16,600)	(61,800)	(16,600)	(82,900)	(20,700)	(103,600)
	Gross CV	kW	5.4	13.4	5.4	16.6	5.4	20.1	5.4	27.0	6.7	33.7
		(Btu/h)	(18,400)	(45,800)	(18,400)	(56,800)	(18,400)	(68,600)	(18,400)	(92,000)	(23,000)	(115,000)
Gas Consumption		m <sup>3</sup> /h	0.500	1.246	0.500	1.537	0.500	1.872	0.500	2.512	0.623	3.135
		(ft <sup>3</sup> /h)	(17.8)	(44.1)	(17.8)	(54.7)	(17.8)	(66.1)	(17.8)	(89)	(22)	(111)
Boiler Output :												
Non Condensing		kW	4.8	12.0	4.8	15.0	4.8	18.0	4.8	24.2	6.1	30.3
	70°C Mean Water temp.	(Btu/h)	(16,500)	(41,100)	(16,500)	(51,300)	(16,500)	(61,600)	(16,500)	(82,600)	(20,700)	(103,300)
Condensing		kW	5.1	13.0	5.1	15.9	5.1	19.1	5.1	25.6	6.4	31.0
	40°C Mean Water temp.	(Btu/h)	(17,500)	(44,600)	(17,500)	(54,250)	17,500	(65,100)	(17,500)	(87,400)	(21,800)	(105,800)
Seasonal efficiency* (SEDBUK) 2005			91.2%		91.1%		91%		91%		91.1%	
Seasonal efficiency* (SEDBUK) 2009			89.4%		89.3%		89.2%		89.5%		89.6%	
NOx Classification			CLASS 5									

\* The value is used in the UK Government's Standard Assessment Procedure (SAP) for energy rating of dwellings. The test data from which it has been calculated have been certified by a notified body.

**Note.** Gas consumption is calculated using a calorific value of 38.7 MJ/m<sup>3</sup> (1038 Btu/ft<sup>3</sup>) gross or 34.9 MJ/m<sup>3</sup> (935 Btu/ft<sup>3</sup>) nett

To obtain the gas consumption at a different calorific value:

- a. For l/s - divide the gross heat input (kW) by the gross C.V. of the gas (MJ/m<sup>3</sup>)
- b. For ft<sup>3</sup>/h - divide the gross heat input (Btu/h) by the gross C.V. of the gas (Btu/ft<sup>3</sup>)
- c. For m<sup>3</sup>/h - multiply l/s by 3.6

**Key to symbols**

**gB** = United Kingdom    **IE** = Ireland    (Countries of destination)

**pMs** = Maximum operating pressure of water

**C<sub>13</sub> C<sub>33</sub> C<sub>53</sub>** = A room sealed appliance designed for connection via ducts to a horizontal or vertical terminal, which admits fresh air to the burner and discharges the products of combustion to the outside through orifices which, in this case, are concentric. The fan is up stream of the combustion chamber.

**I<sub>2h</sub>** = An appliance designed for use on 2nd Family gas, Group H only.

**IDEAL LOGIC HEAT**

Natural gas only

Boiler size	g.C. appliance No. (Benchmark No.)	pl No.
12	41-399-99	86 CL 08
15	41-409-93	86 CL 08
18	41-409-94	86 CL 08
24	41-409-95	86 CL 08
30	41-409-96	86 CL 08

Destination Country: GB, IE

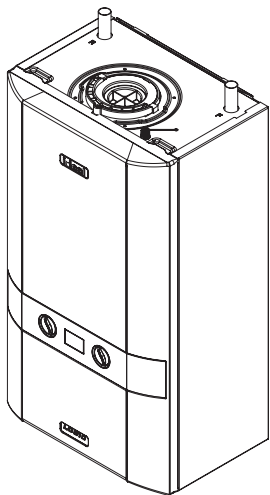

**CONTENTS**

air supply ..... 9  
 Benchmark Commissioning Checklist ..... 58  
 Boiler Clearances ..... 10  
 Boiler Exploded Diagram ..... 15  
 Condensate Drain ..... 9,29,30,46  
 Commissioning & Testing ..... 35  
 Electrical Connections ..... 31  
 Electrical supply ..... 9  
 Fault Finding ..... 50  
 Flue Fitting ..... 19  
 Flue Installation ..... 8  
 gas safety Regulations ..... 7  
 gas supply ..... 8  
 Initial Lighting ..... 36  
 Installation ..... 15-37  
 safe handling ..... 6  
 servicing ..... 38-49  
 spare parts Info ..... 55  
 Thermostatic Radiator Valves ..... 9  
 Water and systems ..... 9,11-14  
 Water & gas Connections ..... 31  
 Water Treatment ..... 14  
 Wiring Diagram ..... 34

For GB, to comply with Building Regulations Part L1 (Part 6 in Scotland) the boiler should be fitted in accordance with the manufacturer's instructions. Self-certification that the boiler has been installed to comply with Building Regulations can be demonstrated by completing and signing the Benchmark Commissioning Checklist.

Before installing this boiler, read the Code of Practice sheet at the rear of this book.

**BENCHMaRK COMMISSIOING CHECKLISt DET aILs**

Boiler	page		page
Make and model.....	5	Burner operating pressure .....	n/a
Appliance serial no. on data badge .....	Front Cover	Central heating flow temp. ....	measure and record
SEDBUK No. %.....	4	Central heating return temp. ....	measure and record
<b>Controls</b>		<b>For combination boilers only</b>	
Time and temperature control to heating .....	33	Scale reducer .....	14
Time and temperature control to hot water .....	33	<i>Hot water mode</i>	
Heating zone valves.....	n/a	Heat input.....	to be calculated
TRV's.....	9	Max. operating burner pressure .....	n/a
Auto bypass .....	9	Max. operating water pressure.....	measure & record
Boiler interlock.....	9	Cold water inlet temp .....	measure & record
<b>For .....</b>	<b>all boilers</b>	Hot water outlet temp .....	measure & record
Flushing to BS.7593.....	14	Water flow rate at max. setting.....	measure & record
Inhibitor .....	14	<b>For condensing boilers only</b>	
<i>Central heating mode</i>		Condensate drain.....	29
Heat input.....	to be calculated	<b>For all boilers:</b>	<i>complete, sign &amp; hand over to customer</i>

For assistance see Technical Helpline on the back page

**NOTE TO ThE INStALLER: COMpLETE  
 ThE BENCHMaRK COMMISSIOING  
 ChECKLISt aND LEa VE ThEsE  
 INStRUCTIO NS WITH aPPLIa NCE**



## INTRODUCTION

The **Logic heat** range of boilers are wall mounted, full sequence, automatic spark ignition, low water content, fanned flue, high efficiency, condensing, heating only gas boilers.

**Note.** *Due to the high efficiency of the boiler a plume of water vapour will form at the terminal during operation.*

Central heating (CH) output is fully modulating with a range of:

12	4.8 to 12kW (16,500 to 41,100 Btu/h)
15	4.8 to 15kW (16,500 to 51,300 Btu/h)
18	4.8 to 18kW (16,500 to 61,600 Btu/h)
24	4.8 to 24.2kW (16,500 to 82,600 Btu/h)
30	6.1 to 30.3kW (20,700 to 103,300 Btu/h)

A variable CH temperature control is fitted on the user control.

The boiler includes as standard:

- Boiler frost protection

**Notes.** *The appliance must be wired with a permanent live supply, or the boiler frost protection will not operate.*

*The System pump must be wired to the boiler.*

*The boiler warranty will be invalid if these requirements are not complied with.*

The boiler casing is of white painted mild steel.

The boiler temperature control is visibly located in the control panel on the front of the boiler.

The heat exchanger is manufactured from cast aluminium.

Note that these boilers cannot be used on systems which include gravity circulation.

The boiler is suitable for connection to fully pumped open vented or sealed water systems. Adequate arrangements for completely draining the system by provision of drain cocks **MUST** be provided in the installation pipework.

Pipework from the boiler is routed upwards.

A rear flue outlet kit (55/80) is available which provides a compact installation.

## OpERaTION

When there is a demand for CH, the heating system is supplied at the selected temperature of between 30°C and 80°C.

The boiler features a comprehensive diagnostic system which gives detailed information on the boiler status when operating, and performance of key components to aid commissioning and fault finding.

## saFE haNDLING

This boiler may require 2 or more operatives to move it to its installation site, remove it from its packaging base and during movement into its installation location. Manoeuvring the boiler may include the use of a sack truck and involve lifting, pushing and pulling.

Caution should be exercised during these operations.

Operatives should be knowledgeable in handling techniques when performing these tasks and the following precautions should be considered:

- Grip the boiler at the base.
- Be physically capable.
- Use personal protective equipment as appropriate, e.g. gloves, safety footwear.

During all manoeuvres and handling actions, every attempt should be made to ensure the following unless unavoidable and/or the weight is light.

- Keep back straight.
- Avoid twisting at the waist.
- Avoid upper body/top heavy bending.
- Always grip with the palm of the hand.
- Use designated hand holds.
- Keep load as close to the body as possible.
- Always use assistance if required.

## OpTIONaL ExTRa KITs

- **horizontal Flue Terminal** (600mm long)
- **horizontal Flue Terminal** (1000mm long)
- **Horizontal Flue Telescopic**
- **Rear Flue Outlet Kit (55/80)**
- **Flue Extension Ducts** (1000mm long)
  - 12 - 24 up to 9m
  - 30 up to 8m
- **Flue Finishing Kit (60/100)**
- **Flue Finishing Kit (55/80)**
- **90° Elbow Kit** (maximum per installation).
  - 12 - 30 up to 6 elbows
- **45° Elbow Kit** (maximum per installation).
  - 12 - 30 up to 6 elbows
- **Concentric Flue screw Retaining Kit**
- **Roof Flue Kit** (to a maximum of 7.5m)
- **powered Vertical Flue Kit** (5m primary and 17m secondary is a typical maximum length. For alternative details refer to Powered Vertical Instructions)
- **High Level Flue Outlet Kit - 60/100**
- **High Level Flue Outlet Kit - 55/80 (Rear Flue only)**
- **Raised Horizontal Flue Outlet Kit**
- **Flue Deflector Kit**
- **Adjustable Flue Support Bracket**
- **Balcony Flue Kit**
- **Terminal Wall Plate Kit**
- **Weather Collar (Universal)**
- **Weather Collar (Flat Roof)**
- **Stand-Off Kit**
- **Condensate Pump Kit**
- **Weather Compensation Kit**
- **Security Bracket Kit**

## saFETy

### Current gas safety (installation and use) regulations or rules in force:

The appliance is suitable only for installation in GB and IE and should be installed in accordance with the rules in force.

In GB, the installation must be carried out by a Gas Safe Registered Engineer. It must be carried out in accordance with the relevant requirements of the:

- Gas Safety (Installation and Use) Regulations
- The appropriate Building Regulations either The Building Regulations, The Building Regulations (Scotland), Building Regulations (Northern Ireland).
- The Water Fittings Regulations or Water byelaws in Scotland.
- The Current I.E.E. Wiring Regulations.

Where no specific instructions are given, reference should be made to the relevant British Standard Code of Practice.

In IE, the installation must be carried out by a Registered Gas Installer (RGI) and installed in accordance with the current edition of I.S.813 "Domestic Gas Installations", the current Building Regulations and reference should be made to the current ETCI rules for electrical installation.

Detailed recommendations are contained in the following British Standard Codes of Practice:

- Bs. 5440:1** Flues (for gas appliances of rated input not exceeding 70 kW).
- Bs. 5440:2** Ventilation (for gas appliances of rated input not exceeding 70 kW).
- BsEN. 12828:2003** Heating Systems in buildings: Design for water based heating systems.
- BsEN 12831:2003** Heating Systems in buildings: Method for calculation of the design heat load.
- BsEN 14336:2004** Heating Systems in buildings: Installation and commissioning of water based heating systems.
- Bs. 5546** Installation of gas hot water supplies for domestic purposes (2nd Family Gases)
- Bs. 6798** Installation of gas fired hot water boilers of rated input not exceeding 70 kW.
- Bs. 6891** Low pressure installation pipes.

### health & safety Document No. 635.

### The Electricity at Work Regulations, 1989.

The manufacturer's notes must NOT be taken, in any way, as overriding statutory obligations.

**IMpORTANT.** These appliances are CE certificated for safety and performance. It is, therefore, important that no external control devices, e.g. flue dampers, economisers etc., are directly connected to these appliances unless covered by these Installation and Servicing Instructions or as otherwise recommended by **Ideal stelrad group** in writing. If in doubt please enquire.

Any direct connection of a control device not approved by **Ideal stelrad group** could invalidate the certification and the normal appliance warranty. It could also infringe the Gas Safety Regulations and the above regulations.

## saFE haNDLING OF sUBSt aNCES

No asbestos, mercury or CFCs are included in any part of the boiler or its manufacture.

## LOCaTION OF BOILER

The boiler must be installed on a flat and vertical internal wall, capable of adequately supporting the weight of the boiler and any ancillary equipment.

The boiler may be fitted on a combustible wall and insulation between the wall and the boiler is not necessary, unless required by the local authority.

For electrical safety reasons there must be no access available from the back of the boiler.

**The boiler must not be fitted outside.**

### Timber Framed Buildings

If the boiler is to be fitted in a timber framed building it should be fitted in accordance with the Institute of Gas Engineering document IGE/UP/7:2006 - Edition 2.

### Bathroom Installations

This appliance is rated **Ip20**.

The boiler may be installed in any room or internal space, although particular attention is drawn to the requirements of the current IEE (BS.7671) Wiring Regulations and the electrical provisions of the building regulations applicable in Scotland, with respect to the installation of the boiler in a room or internal space containing a bath or shower. For IE reference should be made to the current ETCI rules for electrical installations and I.S. 813:2002.

If the appliance is to be installed in a room containing a bath or shower then, providing water jets are not going to be used for cleaning purposes (as in communal baths/showers), the appliance must be installed beyond Zone 2, as detailed in BS.7671.

### Compartment Installations

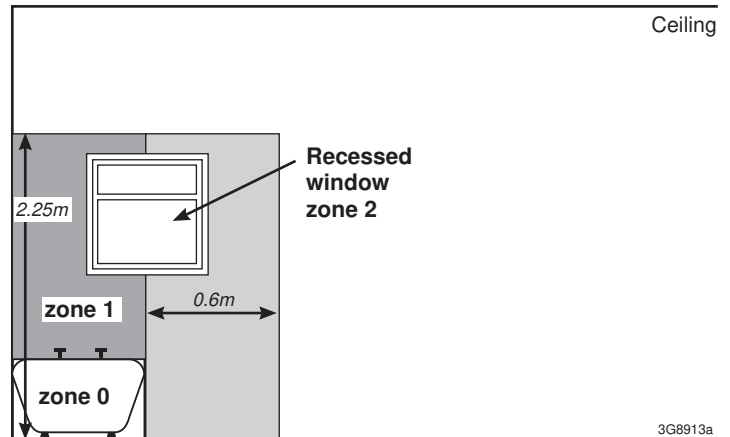

A compartment used to enclose the boiler should be designed and constructed specially for this purpose.

An existing cupboard or compartment may be used, provided that it is modified for the purpose.

In both cases, details of essential features of cupboard / compartment design, including airing cupboard installation, are to conform to the following:

- BS 6798 (No cupboard ventilation is required - see 'Air Supply' for details).
- The position selected for installation MUST allow adequate space for servicing in front of the boiler.
- For the minimum clearances required for safety and subsequent service, see the wall mounting template and Frame 1. In addition, sufficient space may be required to allow lifting access to the wall mounting plate.

## gas supply

The local gas supplier should be consulted, at the installation planning stage, in order to establish the availability of an adequate supply of gas. An existing service pipe must NOT be used without prior consultation with the local gas supplier.

The boiler MUST be installed on a gas supply with a governed meter only.

A gas meter can only be connected by the local gas supplier or by a Gas Safe Registered Engineer. In IE by a Registered Gas Installer (RGII).

An existing meter should be checked, preferably by the gas supplier, to ensure that the meter is adequate to deal with the rate of gas supply required.

It is the responsibility of the Gas Installer to size the gas Installer to size the gas installation pipework in accordance with BS6891:2005. Whilst the principle of the 1:1 gas valve ensures the Logic range is able to deliver its full output at inlet pressures as low as 14mb, other gas appliances in the property may not be as tolerant. When operating pressures are found to be below the minimum meter outlet of 19mb these should be checked to ensure this is adequate for correct and safe operation.

Allowing for the acceptable pressure loss of 1mb across the installation pipework, it can be assumed that a minimum permitted operating pressure of 18mb will be delivered to the inlet of the appliance. (Reference BS 6400-1 Clause 6.2 Pressure Absorption).

The external gas cock could further reduce the operating pressure when measured at its test point. The pressure drop is relative to the heat input to the boiler (kW), refer to graph below.

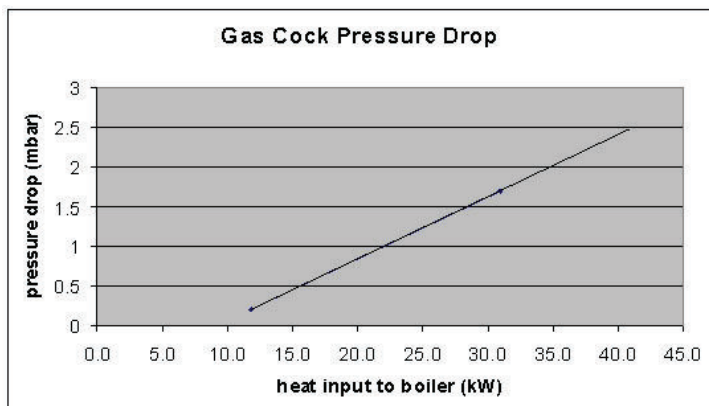

## IMPORtaNT.

Installation pipes must be fitted in accordance with BS.6891. In IE refer to IS.813:2002.

The complete installation MUST be tested for gas tightness and purged as described in the above code.

## FLUE INStALLaTION

Plumbing will occur at the terminal so terminal positions where this could cause a nuisance should be avoided.

The flue must be installed in accordance with the recommendations of BS. 5440-1: 2008. In IE refer to I.S. 813:2002.

The following notes are intended for general guidance:

1. The boiler MUST be installed so that the terminal is exposed to external air.
2. It is important that the position of the terminal allows the free passage of air across it at all times.
3. Minimum acceptable spacing from the terminal to obstructions and ventilation openings are specified in Table 3.

4. Where the lowest part of the terminal is fitted less than 2m (6'6") above a balcony, above ground or above a flat roof to which people have access then the terminal MUST be protected by a purpose designed guard.

Terminal guards are available from boiler suppliers. (Ask for TFC flue guard model no. K6 - round, plastic coated). In case of difficulty contact:

TFC Group Ltd. Tel. + 44 (0) 01732 351 680  
Tower House, Vale Rise Fax. + 44 (0) 01732 354 445  
Tonbridge. Kent TN9 1TB www.tfc-group.co.uk

Ensure that the guard is fitted centrally.

5. The flue assembly shall be so placed or shielded as to prevent ignition or damage to any part of any building.
6. The air inlet/products outlet duct and the terminal of the boiler MUST NOT be closer than 25mm (1") to combustible material. Detailed recommendations on the protection of combustible material are given in BS. 5440-1:2008.

**IMPORtaNT.** It is essential to ensure, in practice, that products of combustion discharging from the terminal cannot re-enter the building or buildings through any openings into the building such as ventilators, windows, doors, or other sources of natural air infiltration, such as forced ventilation openings etc.

If products of combustion re-entry is identified or suspected this should be immediately investigated and corrected following the guidance provided in the current Gas Industry Unsafe Situation Procedure.

Table 3 - Balanced Flue Terminal position

Flue Terminal positions	Min. spacing*
1. Directly below, above or alongside an opening window, air vent or other ventilation opening.	300mm (12")
2. Below guttering, drain pipes or soil pipes. BS5440-1 2008	25mm (1")* 75mm (3")
3. Below eaves. BS5440-1 2008	25mm (1")* 200mm (8")
4. Below balconies or a car port roof. BS5440-1 2008	25mm (1")* 200mm (8")
5. From vertical drain pipes or soil pipes. BS5440-1 2008	25mm (1")* 150mm (6")
6. From an internal or external corner or to a boundary along side the terminal. BS5440-1 2008	25mm (1")* 300mm (12")
7. Above adjacent ground, roof or balcony level.	300mm (12")
8. From a surface or a boundary facing the terminal.	600mm (24")
9. From a terminal facing a terminal.	1,200mm (48")
10. From an opening in a car port (e.g. door or window) into dwelling.	1,200mm (48")
11. Vertically from a terminal on the same wall.	1,500mm (60")
12. Horizontally from a terminal on the wall.	300mm (12")
Vertical Terminals	
13. Above the roof pitch with roof slope of all angles. Above flat roof.	300mm (12") 300mm (12")
14. From a single wall face. From corner walls.	300mm (12") 300mm (12")
15. Below velux window	2000mm (79")
16. Above or side of velux window	600mm (24")

\* Only one reduction down to 25mm is allowable per installation otherwise BS5440-1 2008 dimensions must be followed.

## TERMINAL

The terminal assembly can be adapted to accommodate various wall thicknesses. Refer to Frame 1 .

## AIR SUPPLY

It is NOT necessary to have a purpose-provided air vent in the room or internal space in which the boiler is installed. Neither is it necessary to ventilate a cupboard or compartment in which the boiler is installed, due to the low surface temperatures of the boiler casing during operation; therefore the requirements of BS 6798, Clause 12, and BS 5440:2 may be disregarded.

## WATER CIRCULATION SYSTEM

### IMPORTANT.

A minimum length of 1 metre of copper pipe MUST be fitted to both flow and return connections from the boiler before connection to any plastic piping.

The central heating system should be in accordance with BS.6798 and, in addition, for smallbore and microbore systems, BS.5449.

### heat Exchanger pressure Loss

Boiler size		12	15	18	24	30
Boiler Output	kW But/H	12 41,100	15 51,300	18 61,600	24.2 82,600	30.3 103,300
Water Flow Rate	l/min g/min	8.6 (1.9)	10.7 (2.4)	13 (2.8)	17.2 (3.8)	21.5 (4.7)
Temp Differential	°C °F	20 36	20 36	20 36	20 36	20 36
Pressure Loss	M.Wg FT.WG	0.5 1.7	0.7 2.3	1.0 3.1	1.6 5.2	2.4 8.0

### WATER TREATMENT - see Frame 9

## BOILER CONTROL INTERLOCKS

Central heating systems controls should be installed to ensure the boiler is switched off when there is no demand for heating, in compliance with Building Regulations.

Heating systems utilising full thermostatic radiator valve control of temperature in individual rooms should also be fitted with a room thermostat controlling the temperature in a space served by radiators not fitted with such a valve.

When thermostatic radiator valves are used, the space heating temperature control over a living / dining area or hallway having a heating requirement of at least 10% of the minimum boiler heat output should be achieved using a room thermostat, whilst other rooms are individually controlled by thermostatic radiator valves. However, if the system employs thermostatic radiator valves on all radiators, or two port valves, then a bypass circuit must be fitted with an automatic bypass valve to ensure a flow of water should all valves be in the closed position.

## ELECTRICAL SUPPLY

### Warning.

This appliance must be earthed.

Wiring external to the appliance MUST be in accordance with the current I.E.E. (BS.7671) Wiring Regulations and any local regulations which apply. For IE reference should be made to the current ETCI rules for electrical installations.

The mains supply to the boiler and system wiring centre shall be through one common fused double pole isolator. For new heating systems, and where practicable replacement boiler installation, the isolator shall be situated adjacent to the appliance.

**NOTE. The appliance must be Wired With a permanent live supply. The system pump must be Wired To The boiler (see Frame 37). The boiler Warranty Will be invalid if This requirement is not complied With.**

## CONDENSATE DRAIN

### Refer to Frames 32 & 33

A condensate drain is provided on the boiler. This drain must be connected to a drainage point on site. All pipework and fittings in the condensate drainage system MUST be made of plastic - *no other materials may be used.*

### IMPORTANT.

Any external runs must be in accordance with BS 6798.

The drain outlet on the boiler is sized for standard 21.5mm (3/4") overflow pipe. It is a universal fitting to allow use of different brands of pipework.

## 1 BOILER DIMENSIONS, sERVICEs & CLEaRaNCES

*all dimensions in mm*

The boiler connections are made on the boiler connection tails. Refer to Frame 34.

**The following minimum clearances must be maintained for operation and servicing.**

Additional space will be required for installation, depending upon site conditions.

### side and Rear Flue

a. Provided that the flue hole is cut accurately, e.g. with a core drill, the flue can be installed from inside the building where

wall thicknesses do not exceed 600mm (24"). Where the space into which the boiler is going to be installed is less than the length of flue required the flue must be fitted from the outside.

### Installation from inside ONLY

b. If a core boring tool is to be used inside the building the space in which the boiler is to be installed must be at least wide enough to accommodate the tool.

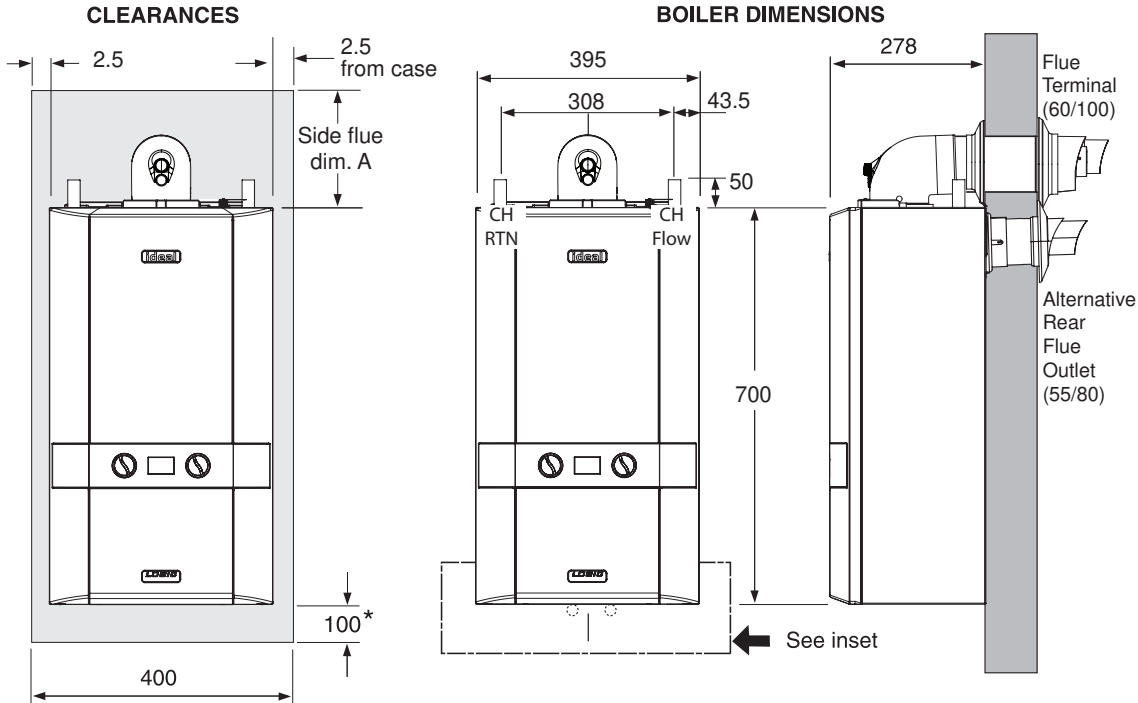

### Inset: Condensate Connection and gas Connection

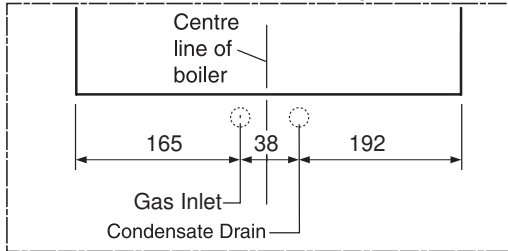

### Front clearance

The minimum front clearance when built in to a cupboard is 5mm from the cupboard door but 450mm overall clearance is still required, with the cupboard door open, to allow for servicing.

### \* Bottom clearance

Bottom clearance after installation can be reduced to 5mm. This must be obtained with an easily removable panel, to enable the consumer to view the system pressure gauge, and to provide the 100mm clearance required for servicing.

### Min Top Clearance "A" 165mm Rear flue type

Min Top Clearance (mm)	(167)	(193)	(219)	(245)	(271)	(297)	(323)	(349)	(375)	(401)
"A")SIDE Flue type	26	52	78	104	130	156	182	208	234	260
Distance from Horizontal (mm) required to achieve 1.5deg fall to the appliance										

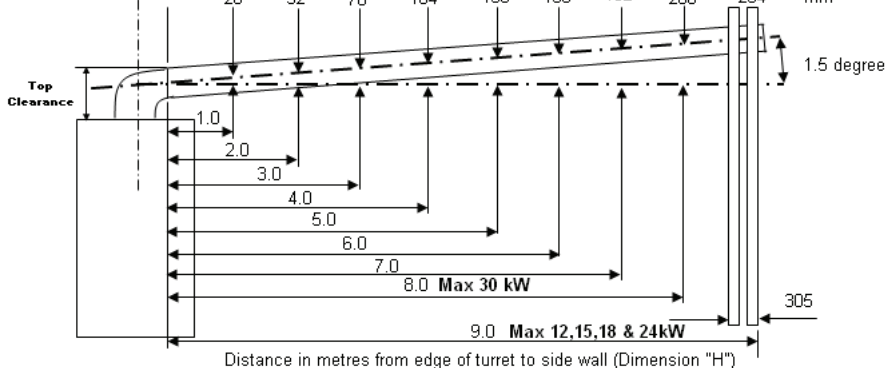

1. Dimension "H" must remain inside the Maximum flue length requirement for the designated kW capacity of the appliance been installed.
  2. For flue lengths requiring "D" pack extensions the flue must incline by 26mm per 1 Metre of flue length.
- No flue length greater that the maximum flue length shown above should be exceeded.

## 2 OpEN VENT sYSTEM REQUIREMENTS

The system should be vented directly off the boiler flow pipe, as close to the boiler as possible. The cold feed entry should be inverted and **MUST** be positioned between the pump and the vent, and not more than 150mm (6") away from the vent connection.

**Note.** Combined feed and vent pipes may also be fitted.

There should be a minimum height 450mm (18") of open vent above the cistern water level. If this is not possible refer to Frame 5. The vertical distance between the highest point of the system and the feed/expansion cistern water level **MUST** not be less than 450 mm (18"). The pump must be fitted on the flow side of the boiler.

A suitable pump is a domestic circulator capable of providing a maximum 20°C temperature differential across the boiler with the whole of the heating circuit open (e.g. Grundfos UPS 15/50, 15/60 or equivalent). With the minimum flow circuit allowed by the controls the differential must not exceed 25 °C.

The vertical distance between the pump and feed/expansion cistern **MUST** comply with the pump manufacturer's minimum requirements, to avoid cavitation. Should these conditions not apply either lower the pump position or raise the cistern above the minimum requirement specified by **Ideal stelrad group**. The isolation valves should be fitted as close to the pump as possible.

It is recommended that an automatic air vent should be fitted to the return connection.

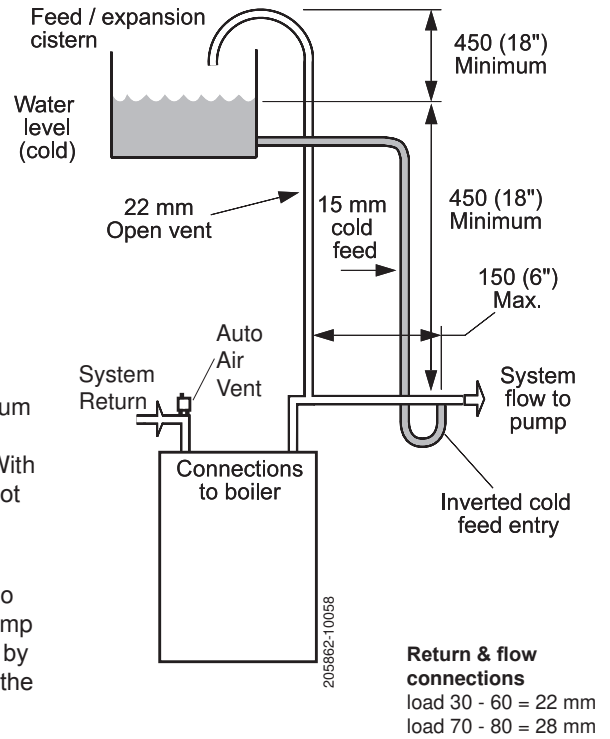

## 3 sChEMa TIC plpEWORk AND sYSTEM BalANcING

The boiler does not normally need a bypass but at least some radiators on the heating circuit, of load at least 10% of the minimum boiler output, must be provided with twin lockshield valves so that this minimum heating load is always available (see footnote re. thermostatic radiator valves).

### Balancing

1. Set the programmer to ON for both CH and HW. Turn the cylinder thermostat down. Close the manual or thermostatic valves on all radiators, leaving the twin lockshield valves (on the radiators referred to above) in the open position. Turn up the room thermostat and adjust these lockshield valves to give boiler flow and return temperatures not more than 20°C apart. These valves should now be left as set.
2. Open all manual or thermostatic radiator valves and adjust the lockshield valves on remaining radiators to give around 20°C temperature drop at each radiator.
3. Turn up the cylinder thermostat and adjust the cylinder balancing valve so that the cylinder achieves a maximum flow consistent with adequate flow to the radiators. Check that with only the domestic hot water loop in circuit a differential temperature of 25°C across the boiler is not exceeded.
4. Adjust room and cylinder thermostats and programmer to NORMAL settings.

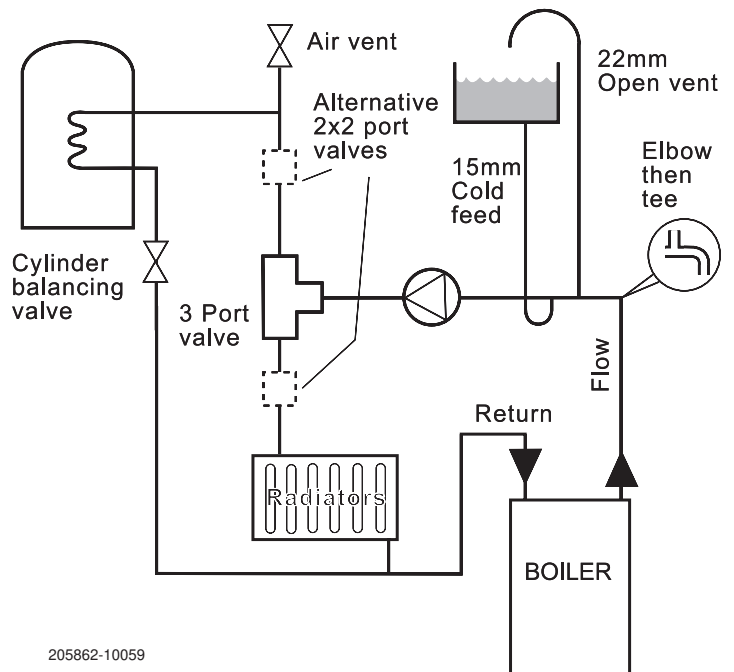

#### 4 LOW hEaD aND LaRgE sYsTEMs WITH ExTENSIVE plpE RUNs - OpEN VENT

This arrangement is useful for large systems where radiators at the extremities are difficult to vent. This can lead to pumping over with conventional feed and vent arrangements.

The following conditions MUST be observed:

1. The top of the automatic air vent must be below the cold water level.
2. The static water level (cold) must be at least 200mm above the top of the horizontal flow pipe, fitted as shown. The vent connection MUST NOT be made immediately off the top of the boiler as venting is made less efficient.
3. The maximum practical length of 22mm cold feed pipe should be used in order to reduce the effective volume of hot system water expanding into the feed/expansion cistern to a minimum.

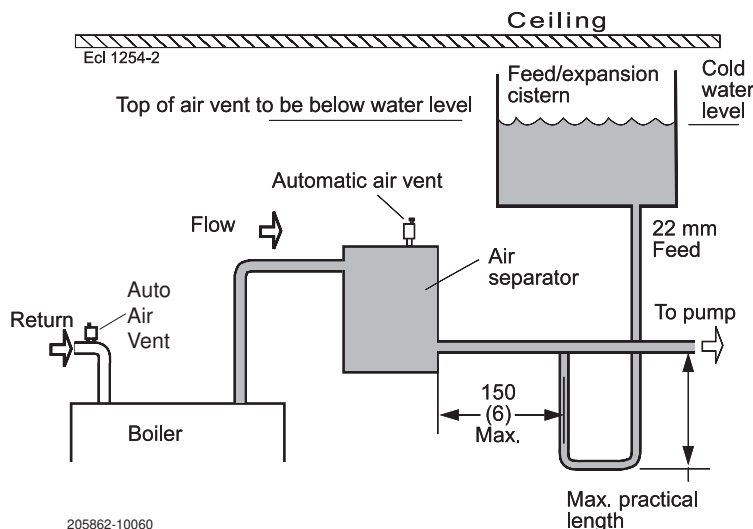

205862-10060

All dimensions in mm (in.).

NB. Imperial dimensions are approximate

#### 5 sEaLED sYsTEM REQUIREMENTS

##### Notes.

- a. The method of filling, refilling, topping up or flushing sealed primary hot water circuit from the mains via a temporary hose connection is only allowed if acceptable to the local water authority.
- b. When installing the filling device, it must be connected as shown to fully comply with the water regulations. This may involve the fitting of an additional WRAS approval isolator valve to the mains supply.

##### 1. general

- a. The installation must comply with the requirements of BS. 6798 and BS. 5449.
- b. The installation should be designed to work with flow temperatures of up to 82 °C.
- c. All components of the system, including the heat exchanger of the indirect cylinder, must be suitable for a working pressure of 3 bar (45lb/in<sup>2</sup>) and temperature of 110°C. Care should be taken in making all connections so that the risk of leakage is minimised.

##### 2. safety Valve

A spring loaded safety valve complying with the relevant requirements of BS. 6759 must be fitted in the flow pipe as close to the boiler as possible and with no intervening valve or restriction. The valve should have the following features:

- a. A non-adjustable preset lift pressure not exceeding 3bar (45lb/in<sup>2</sup>).

- b. A manual testing device.

- c. Provision for connection of a discharge pipe. The valve or discharge pipe should be positioned so that the discharge of water or steam cannot create a hazard to the occupants of the premises or cause damage to electrical components and wiring.

##### 3. pressure gauge

A pressure gauge covering at least the range 0-4 bar (0-60 lb/in<sup>2</sup>) must be fitted to the system. The gauge should be easily seen from the filling point and should preferably be connected at the same point as the expansion vessel.

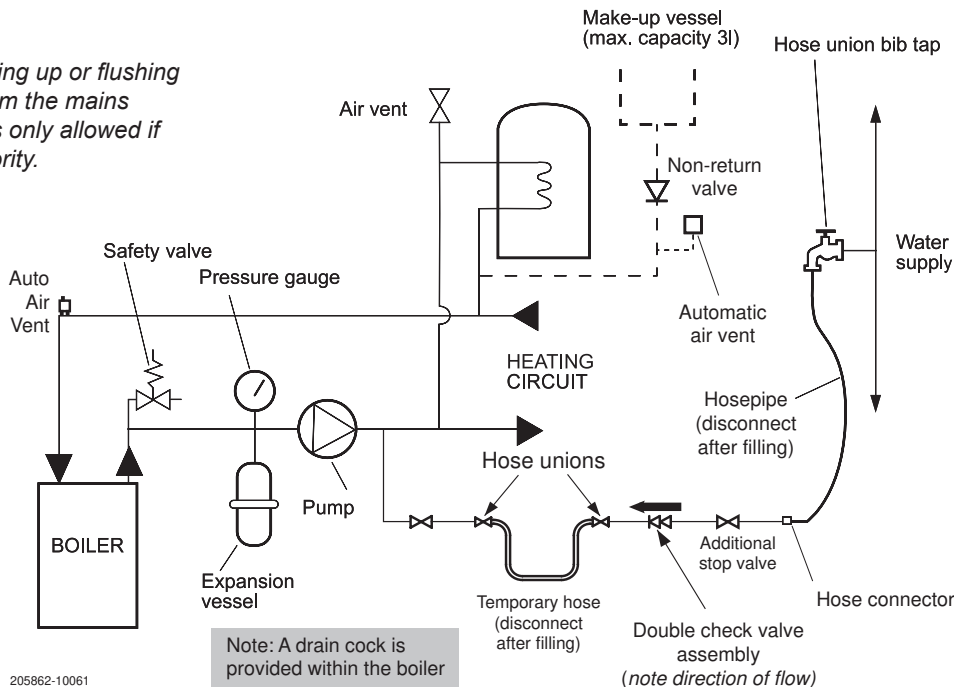

205862-10061

## 6 sEaLED system REqUIREMENTS - continued

### 4. Expansion Vessel

- a. A diaphragm type expansion vessel must be connected to a point close to the inlet side of the pump, the connecting pipe being not less than 15 mm (1/2" nominal) size and not incorporating valves of any sort.
- b. The vessel capacity must be adequate to accept the expansion of the system water when heated to 110°C (230°F).
- c. The charge pressure must not be less than the static water head above the vessel. The pressure attained in the system when heated to 110° C (230° F) should be at least 0.35 bar (5 lb/in<sup>2</sup>) less than the lift pressure of the safety valve.

For guidance on vessel sizing refer to the table in Frame 7.

For further details refer to BS. 5449, BS. 7074:1 and the British Gas Corporation publication 'Material and Installation Specifications for Domestic Central Heating and Hot Water'. For IE refer to the current edition of I.S.813.

### 5. Cylinder

The cylinder must be either of the indirect coil type or a direct cylinder fitted with an immersion calorifier which is suitable for operating on a gauge pressure of 0.35 bar (5 lb/in<sup>2</sup>) in excess of the safety valve setting. Single feed indirect cylinders are not suitable for sealed systems.

### 6. Make-up Water

Provision must be made for replacing water loss from the system, either:

- a. From a manually filled make-up vessel with a readily visible water level. The vessel should be mounted at least 150 mm (6") above the highest point of the system, and be connected through a non-return valve to the system, fitted at least 300 mm (12") below the make-up vessel on the return side of the domestic hot water cylinder or radiators.
- or
- b. Where access to a make-up vessel would be difficult by pre-pressurisation of the system. Refer to 'Filling', below.

### 7. Mains Connection

There must be no direct connection to the mains water supply or to the water storage tank supplying domestic water, even through a non-return valve, without the approval of the local water authority.

### 8. Filling

The system may be filled by one of the following methods:

- a. Through a cistern, used for no other purposes, via a ball valve permanently connected directly to a service pipe and/or a cold water distributing pipe. The static head available from the cistern should be adequate to provide the desired initial system design pressure. The cold feed pipe from the cistern should

include a non-return valve and a stop valve with an automatic air vent connected between them, the stop valve being located between the system and the automatic air vent. The stop valve may remain open during normal operation of the system if automatic water make-up is required.

- b. Through a self-contained unit comprising a cistern, pressure booster pump (if required) and, if necessary, an automatic pressure reducing valve and flow restrictor. The cistern should be supplied through a temporary connection from a service pipe or cold water distributing pipe. This unit may remain permanently connected to the heating system to provide limited automatic water make-up. Where the temporary connection is supplied from a service pipe or distributing pipe which also supplies other draw-off points at a lower level than a double check valve shall be installed upstream of the draw-off point.
- c. Through a temporary hose connection from a draw-off tap supplied from a service pipe under mains pressure. Where the mains pressure is excessive a pressure reducing valve shall be used to facilitate filling.

The following fittings shall form a permanent part of the system and shall be fitted in the order stated:

A stop valve complying with the requirements of BS. 1010, Part 2 (the hose from the draw-off tap shall be connected to this fitting).

A test cock.

A double check valve of an approved type.

- Thoroughly flush out the whole of the system with cold water, without the pump in position.
- With the pump fitted, fill and vent the system until the pressure gauge registers 1.5 bar (21.5lb/in<sup>2</sup>). Examine for leaks.
- Check the operation of the safety valve by manually raising the water pressure until the valve lifts. This should occur within  $\pm 0.3$  bar ( $\pm 4.3$ lb/in<sup>2</sup>) of the preset lift pressure.
- Release water from the system until the initial system design pressure is reached.
- Light the boiler and heat the system to the maximum working temperature. Examine for leaks.
- Turn off the boiler and drain the system while still hot.
- Refill and vent the system.
- Adjust the initial pressure to the required value.

**sizing procedure for expansion vessels:** The volume of the expansion vessel (litres) fitted to a sealed system shall not be less than that given by the table on the following page, multiplied by a factor of 0.8 (for flow temperatures of less than 83° C).

*continued . . . . .*

# gENERaL

## 7 sEaLED sYsTEM REqUIREMENTS - continued

safety valve setting	3.0 bar			2.5 bar			2.0 bar	
Vessel charge and initial system pressure	0.5 bar	1.0 bar	1.5 bar	0.5 bar	1.0 bar	1.5 bar	0.5 bar	1.0 bar
Total water content of system litres	Expansion vessel volume litres							
25	2.1	2.7	3.9	2.3	3.3	5.9	2.8	5.0
50	4.2	5.4	7.8	4.7	6.7	11.8	5.6	10.0
75	6.3	8.2	11.7	7.0	10.0	17.7	8.4	15.0
100	8.3	10.9	15.6	9.4	13.4	23.7	11.3	20.0
125	10.4	13.6	19.5	11.7	16.7	29.6	14.1	25.0
150	12.5	16.3	23.4	14.1	20.1	35.5	16.9	30.0
175	14.6	19.1	27.3	16.4	23.4	41.4	19.7	35.0
200	16.7	21.8	31.2	18.8	26.8	47.4	22.6	40.0
225	18.7	24.5	35.1	21.1	30.1	53.3	25.4	45.0
250	20.8	27.2	39.0	23.5	33.5	59.2	28.2	50.0
275	22.9	30.0	42.9	25.8	36.8	65.1	31.0	55.0
300	25.0	32.7	46.8	28.2	40.2	71.1	33.9	60.0
Multiplying factors for other system volumes	0.0833	0.109	0.156	0.094	0.134	0.237	0.113	0.20

## 8 sYsTEM BaLaNCINg

The boiler does not normally need a bypass but at least some radiators on the heating circuit, of load of at least 10% of the minimum boiler output, must be provided with twin lockshield valves so that this minimum heating load is always available. See note regarding thermostatic radiator valves on page 9.

**Note.** *Systems incorporating zone valves which could completely cut off the flow through the system must also include a bypass.*

### BaLaNCINg

- Set the programmer to ON.  
Close the manual or thermostatic valves on all radiators, leaving the twin lockshield valves (on the radiators referred to above) in the OPEN position.  
Turn up the room thermostat and adjust the lockshield valve to give an uninterrupted flow through the radiator.  
These valves should now be left as set.
- Open all manual or thermostatic radiator valves and adjust the lockshield valves on the remaining radiators, to give around 20°C temperature drop at each radiator.
- Adjust the room thermostat and programmer to NORMAL settings.

## 9 WaTER TREaTMENT

### CENTRaL hEaTING

The Logic Heat range of boilers have an ALUMINIUM alloy heat exchanger.

#### IMpORTANT.

**The application of any other treatment to this product may render the guarantee of Ideal stelrad group invalid.**

**Ideal stelrad group** recommend Water Treatment in accordance with the Benchmark Guidance Notes on Water Treatment in Central Heating Systems.

If water treatment is used **Ideal stelrad group** recommend only the use of Scalemaster Gold 100, FERNOX, MB-1, ADEy MC1 or SENTINEL-X100 inhibitors and associated water treatment products, which must be used in accordance with the manufacturers' instructions.

#### Notes.

- It is most important that the correct concentration of the water treatment products is maintained in accordance with the manufacturers' instructions.*
- If the boiler is installed in an existing system any unsuitable additives MUST be removed by thorough cleansing. BS 7593:2006 details the steps necessary to clean a domestic heating system.*
- In hard water areas, treatment to prevent lime scale may be necessary - however the use of artificially softened water is NOT permitted.*
- Under no circumstances should the boiler be fired before the system has been thoroughly flushed.*

For further information contact:

Fernox Cookson Electronics  
Forsyth Road, Sheerwater, Woking  
Surrey GU21 5RZ  
+44 (0) 870 601 5000

Sentinel Performance Solutions  
The Heath Business & Technical Park  
Runcorn, Cheshire WA7 4QX  
Tel: 0800 389 4670  
www.sentinel-solutions.net

Scalemaster Water Treatment Products  
Emerald Way, Stone, Staffordshire  
ST15 0SR  
Tel:01785 811636

Calmag Ltd.  
Unit 3-6, Crown Works  
Bradford Road, Sandbeds, Keighley  
West yorkshire BD20 5LN  
Tel: +44 (0) 1535 210 320

Adey Professional Heating Solutions  
Gloucester Road,  
Cheltenham GL51 8NR  
Tel: +44 (0) 1242 546700

## 10 BOILER assEMBL y - Exploded View

Note that item numbers are linked to the spares list

- |     |                      |     |                                     |     |                       |
|-----|----------------------|-----|-------------------------------------|-----|-----------------------|
| 103 | HEAT EXCHANGER DRAIN | 223 | FLUE MANIFOLD                       | 307 | ELECTRODE DETECTION   |
| 104 | FLOW SENSOR          | 224 | FLUE MANIFOLD TOP                   | 308 | IGNITOR UNIT          |
| 105 | PIPE - FLOW          | 225 | FLUE MANIFOLD - TOP SEALING CAP     | 313 | IGNITION LEAD         |
| 106 | PIPE - RETURN        | 226 | FLUE MANIFOLD - REAR SEALING CAP    | 314 | CONTROL BOX LENS      |
| 203 | GAS COCK             | 227 | CLAMP RETAINING FLUE TURRET         | 324 | CONTROLS BOX LID      |
| 204 | PIPE - GAS INLET     | 228 | HOSE CONDENSATE INTERNAL            | 325 | CONTROL BOX FRONT     |
| 205 | GAS VALVE            | 229 | SIPHON TRAP                         | 401 | HEAT ENGINE           |
| 206 | PIPE - GAS INJECTOR  | 231 | CONDENSATE OUTLET CONNECTION        | 503 | WALL MOUNTING BRACKET |
| 211 | INJECTOR ASSEMBLY    | 233 | FLUE SENSING NIPPLE                 | 504 | FRONT PANEL           |
| 214 | VENTURI              | 301 | CONTROLS BOX FIXINGS HINGE & SPRING | 505 | FASCIA                |
| 215 | FAN                  | 302 | PRIMARy PCB*                        | 506 | BRACKET - GAS VALVE   |
| 217 | BURNER               | 303 | CUI BOARD                           | 512 | INFILL FRONT PANEL    |
| 218 | GASKET - BURNER      | 304 | CONTROL THERMISTOR (RETURN)         |     |                       |
| 219 | SUMP CLEAN OUT COVER | 306 | ELECTRODE IGNITION                  |     |                       |

\* Note that production boiler PCBs are factory pre-set to operate for boiler range and output, but when ordering Primary PCB as a spare, an additional Boiler Chip Card (BCC) MUST also be purchased for your specific boiler range and output.

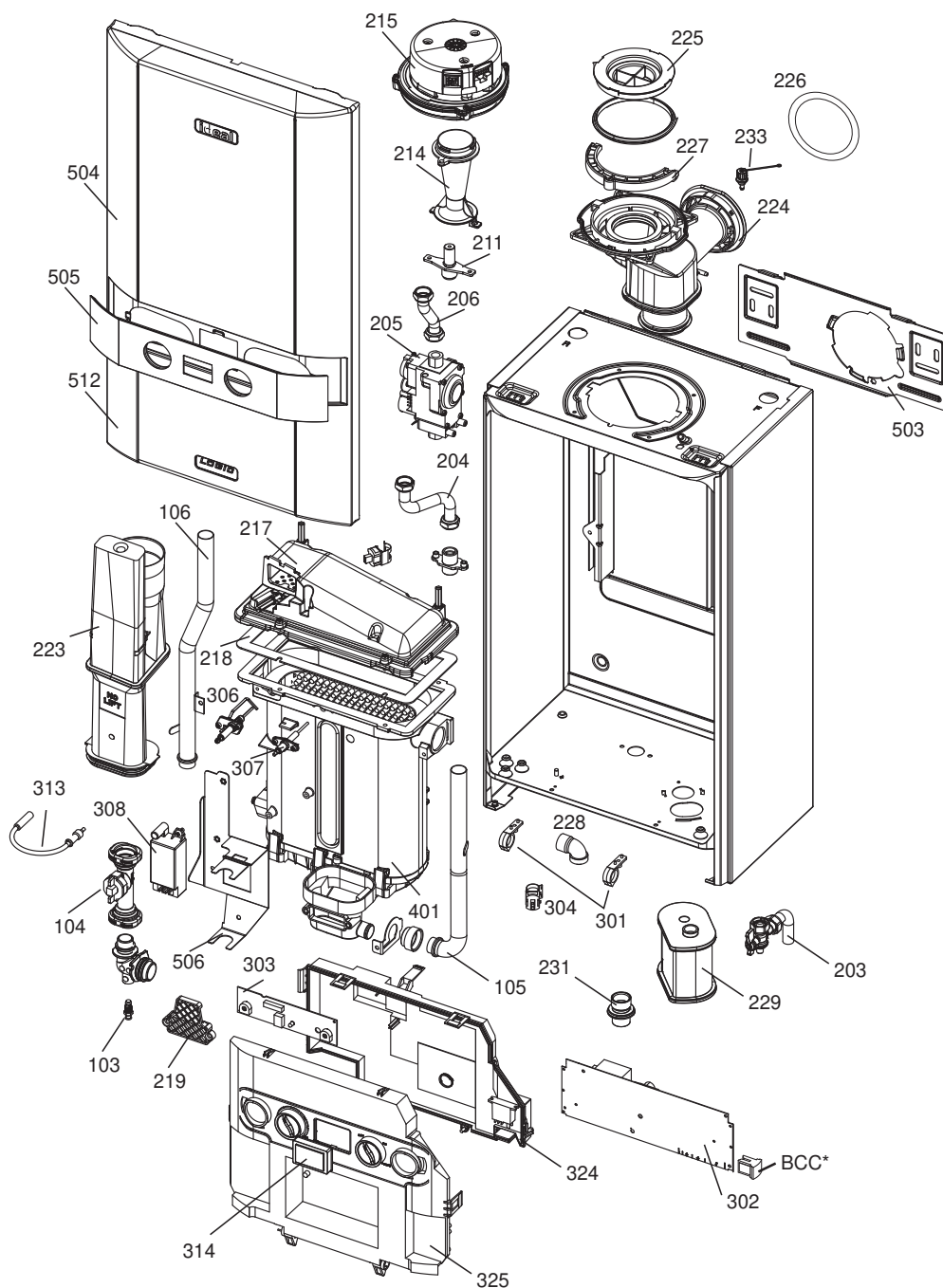

## 11 UNpaCKING

The boiler is supplied fully assembled in Pack A. A telescopic or non-telescopic flue assembly for rear or side flue outlet in Pack B is supplied as a separate order.

**Unpack and check the contents.**

### pack a Contents

- A Boiler
- B Hardware Pack Box
- C Wall Mounting Plate
- D These Installation/Users Instructions
- E Wall Mounting Template (located on internal protective packaging)
- F Boiler Guarantee & Registration Pack
- G Turret Clamp

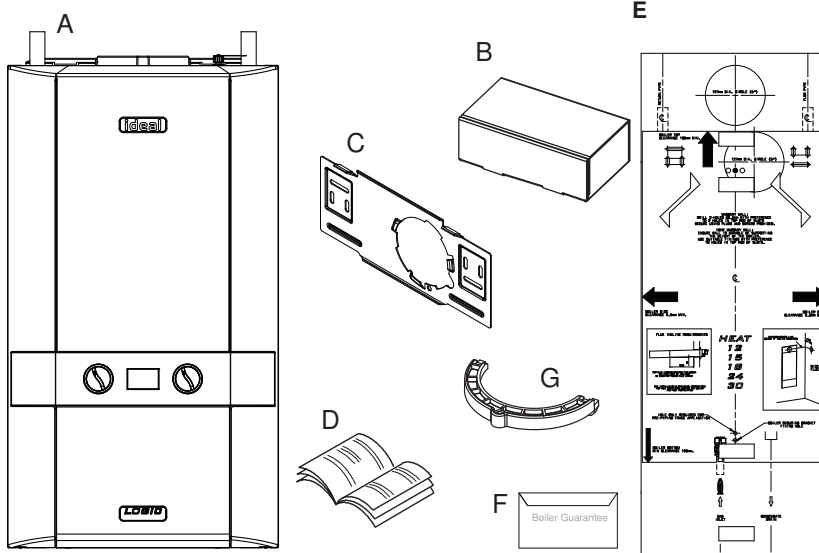

### haRDW aRE paCK CoNTENTS

#### gas Valve pack

1. Washer - Gas (blue)
2. Gas Cock

#### accessory pack

1. Screw (x3)
2. Wallplug (x3)

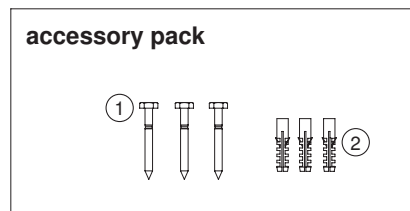
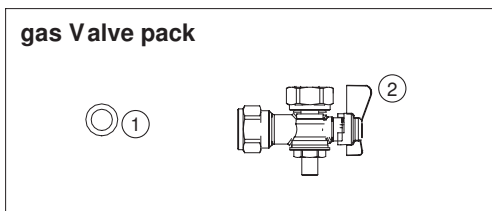

12 UNpaCKING....CONT'D

**Note.** This flue system incorporates a removable flue outlet nose that utilises a push fit location system. This enables the installation of deflector, high level or balcony outlet flue kits without the removal of the whole 'B' pack terminal. The appliance must not be operated without the desired outlet nose correctly fitted in place.

*Note.* Location dimples must be aligned with terminal mounting frame.

**Pack B Contents Rear Flue Outlet Kit (55/80)**

- A Plastic Connector
- B Flue Terminal
- C Rubber terminal wall seal
- D 2 x Self Tapping Screws
- E Sealing Tape
- F Cutting Aid

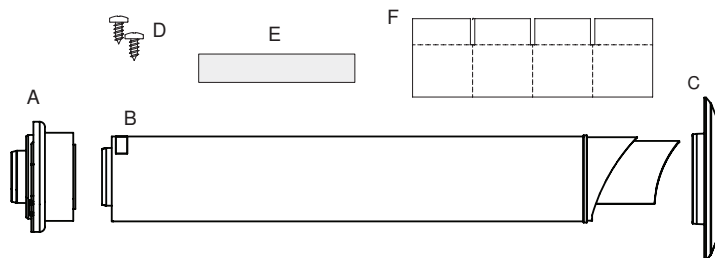

**Pack B Contents Non-Telescopic (60/100)**

- A Flue terminal
- B Flue turret
- C Wall Seal (white)
- D Wall Seal (black)
- E Cutting Aid

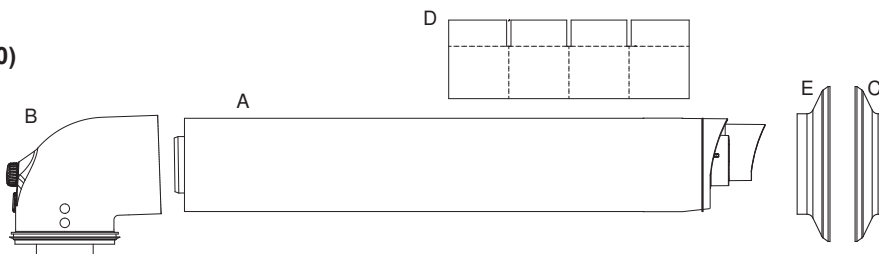

**Pack B Contents Telescopic (60/100)**

- A Telescopic flue terminal
- B Flue turret
- C Wall seal (black)
- D Screw
- E Sealing Tape
- F Wall Seal (White)

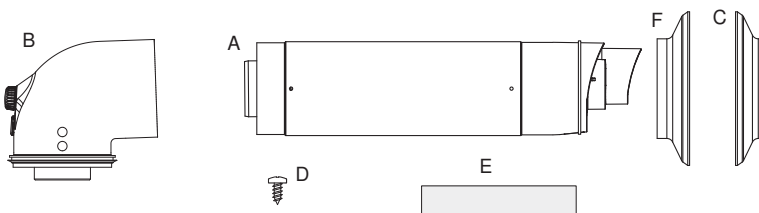

13 FRONT paNEL REMOVal

1. Loosen the 2 screws retaining the front panel.
2. Pull the two spring clips downwards to disengage.
3. Pull the front panel forward and upwards to remove.

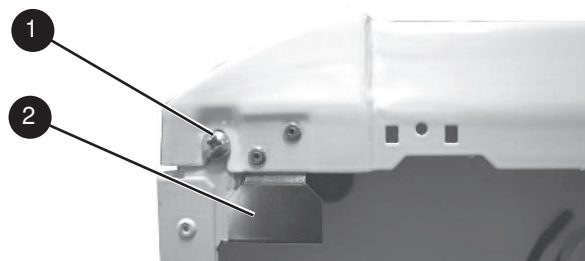

### 14 WaLL MOUNTING TEMPLa TE

The wall mounting template is located on the internal protective packaging. The template shows the position of the fixing and rear flue centre holes for a standard installation

*Care MUST be taken to ensure the correct holes are drilled.*

1. Tape template into the required position, ensuring its squareness by hanging a plumbline as shown.
2. If fitting a side flue, extend the flue centreline onto the side by **155mm** on a standard wall fix or **200mm** if using a stand-off bracket.
3. Mark the following on to the wall:
  - a The selected group of wall mounting screw holes.
  - b. The centre position of the flue duct. Marking both the centre and the circumference of the flue duct.
4. Remove the template plate from the wall.

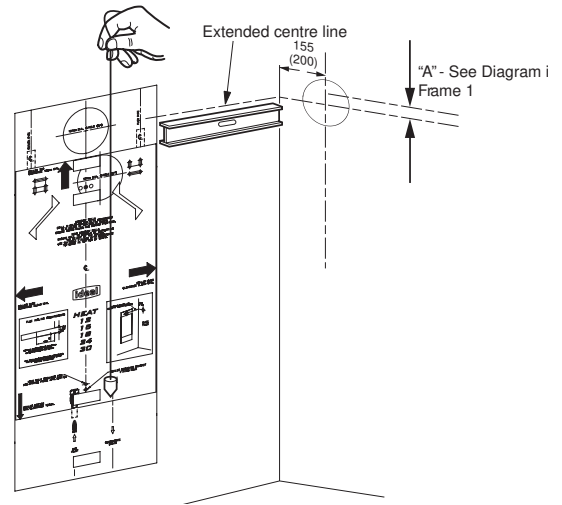

### 15 pREPaRING ThE W aLL

#### IMpORTaNT.

Ensure that, during the cutting operation, masonry falling outside of the building does not cause damage or personal injury.

1. Cut the rear flue hole (preferably with a 5" core boring tool), ensuring that the hole is square to the wall. Both wall faces immediately around the cut hole should be flat.
2. Drill 3 holes with a 7.5mm / 8mm masonry drill and insert the plastic plugs, provided, for the wall mounting plate and the boiler bottom retaining bracket.
3. Locate 2 No.14 x 50mm screws in the wall mounting plate (one at each side, in any of the 3 holes provided at each side) and screw home.

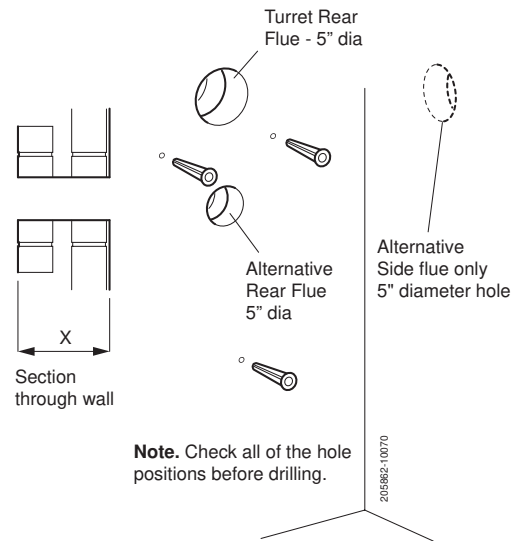

### 16 FITTING ThE WaLL MOUNTING pLa TE (TURRET OpTION)

Screw the wall mounting plate to the wall using 2 wall plugs (previously fitted) with the 2 screws provided.

Choose one of the 2 sets of slots in left and right bank. Ensuring that at least one of the screws is fitted into a top slot and the mounting bracket is level.

Example of fixing

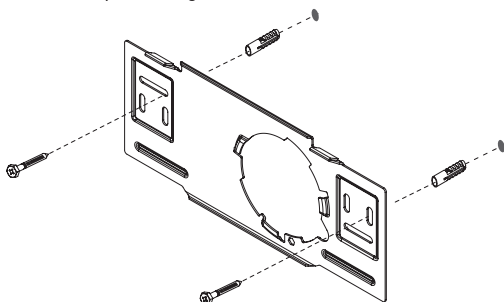

205862-10084

### 17 MOUNTING ThE BOILER (TURRET OpTION)

1. Remove the top flue plastic blanking disc and retain the plastic horseshoe fixing and screw.
 

*Caution: water may discharge from open pipes*
2. Lift the boiler onto the wall mounting plate (refer to the Introduction section for safe handling advice), locating it over the two tabs.
3. Screw the boiler bottom retaining bracket to the wall with the screw provided.

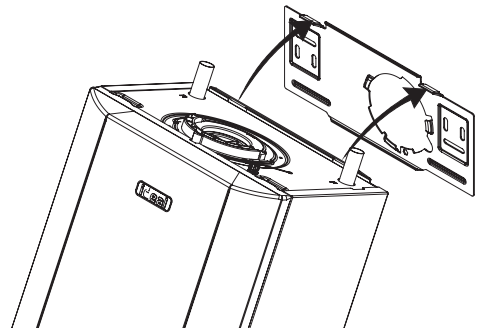

# INsTaLLaTION

## 18 DETERMINING THE FLUE LENGTH AND FLUE PACKS REQUIRED

IMPORTANT. The boiler must be installed in a vertical position in accordance to the installation instructions.

### FLUE KITS

**Telescopic Flue 'B' pack** - contains: Flue turret, telescopic flue incorporating a terminal and rubber wall seals.

**horizontal Flue Terminal (600mm long) 'B' pack** - contains: Flue turret, non telescopic single piece flue incorporating a terminal and rubber wall seals.

**horizontal Flue Terminal (1000mm long) 'B' pack** - Flue turret, telescopic flue incorporating a terminal, rubber wall seals and instructions.

*Note. If 'B' packs are used on their own (either 1 piece or telescopic), then they can be fitted horizontally as the flue inside is designed to slope 1.5 degrees.*

**'D' pack** - contains: 1 metre length of flue pipe (Functional length 950mm), 1 support bracket and instructions.

*When extension 'D' Packs are used the flue duct must incline 1.5 degrees away from the appliance, to allow the condensate to drain back to the boiler and out of the condensate drain. It is recommended that a support bracket is fitted on every 1 metre of pipe work used and the bracket is located as close to the collar as possible. The bracketing must ensure a 1.5 degree fall back to the appliance.*

**Optional Flue Finishing Kit** - UIN 155988 & Concentric Flue Screw Retaining Kit (Optional Kit of mechanical fixing of flue joints)

Only use water as a lubricant during assembly.

The 'B' pack terminal is classed as part of the maximum flue length.

These flue systems incorporates a removable flue outlet nose that utilises a push fit location system. This enables the installation of deflector, high level or balcony flue kits without the removal of the whole 'B' pack terminal. The appliance must not be operated without the desired outlet nose correctly fitted in place, ensuring the side location dimples are in line with the mounting face allowing the correct sealing of the components.

It is IMPORTANT that all attachments are fitted in accordance to the installation instructions provided with them.

The TURRET supplied in the 'B' Pack has an upper combustion sample point with a screw cap seal and a lower air sample point with an air stopper seal. Ensure all caps & seals are in place.

**additional Termination Kits** available for use with these 'B' packs.

Flue Deflector Kit	The resistance is the equivalent of 1 metre of flue pipe and therefore must be deducted from any maximum flue length
High Level Flue Outlet Kit	The maximum permissible concentric flue length when using a standard (500mm) kit is 4.5 metres
Balcony Flue Outlet Kit	The maximum permissible concentric flue length when using this kit is dependant on the length of the balcony flue outlet run which combined with the concentric run must not exceed the maximum flue length requirement of the appliance it is to be fitted to

**Total Maximum permissible horizontal Concentric Flue Length** combining both 'B' Packs and 'D' Packs  
(Measured from centreline of the turret to the outside of the wall terminal)

12, 15, 18, 24 kW appliances	Total Maximum: 9 metres - minus any flue kit options or bends
30 kW Appliances	Total Maximum: 8 metres - minus any flue kit options or bends

**Total Maximum permissible Vertical Flue Length** combining both Roof Terminal and 'D' Packs

12, 15, 18, 24, 30 kW Appliances	Total Maximum (60/100): 7.5 Metres - minus any bends
<b>powered Vertical Flue</b>	
12, 15, 18, 24, 30 kW Appliances	Total Maximum (60/100): 5 Metres - Concentric Flue and 17m flue pipe only. For additional details refer to the powered Vertical Instructions

**REaR FLUEING** This is dedicated flue with no removeable nose section.

**Total Maximum permissible Rear Flue Length**

12, 15, 18, 24, 30 kW Appliances	Total Maximum (50/80) - 442mm - No additional bends etc allow		
12, 15, 18, 24, 30 kW Appliances	Total Minimum (50/80) - 115mm - No additional bends etc allow		
Dedicated High Level Flue Outlet Kit - see kit instruction for further details	(50/80) - Maximum Vertical Run	12 & 30kW - 6 M	155, 18, 24 kW - 11M

*continued . . . . .*

# INsTaLLaTION

## 19 DETERMINING THE FLUE LENGTH AND FLUE PACKS REQUIRED.....CONT'D

90° Elbow Kit 60/100 - (Equivalent flue length resistance = 1M)

45° Elbow Kit 60/100 - (Equivalent flue length resistance = 0.6M)

**Minimum horizontal Flue Lengths** (Centre line of turret to outside of wall terminal)

Telescopic Flue 'B' Pack = 400mm

Horizontal Flue terminal (600mm long) 'B' Pack = 285mm

**Wall Thickness**

Std Metric Brick 102.5mm wide

'B' Pack Flue Type 60/100	Minimum permissible Wall Thickness			Maximum permissible Wall Thickness		
	Rear Flue	Rear Flue + std-Off	side Flue	Rear Flue	Rear Flue + std-Off	side Flue
Horizontal Flue Terminal (600mm long) B Pack	116	102.5	102.5	501	456	456
Telescopic Flue B Pack	231	186	186	429	384	384
Horizontal Flue Terminal (1000mm long) B Pack	546	501	501	761	716	716
Horizontal Flue Terminal (1000mm long) B Pack cut 75mm	471	426	426	686	641	641

For Flue lengths between 658 & 708 use a horizontal Flue Terminal (1000mm long) B pack, cut 75mm off the end of the terminal section of the telescopic flue only.

## 20 DETERMINING THE FLUE LENGTH AND FLUE PACKS REQUIRED, CONT'D

**FIGURE 1**

Note. Maximum permissible flue length is measured from centre line of appliance flue outlet to outside wall face.

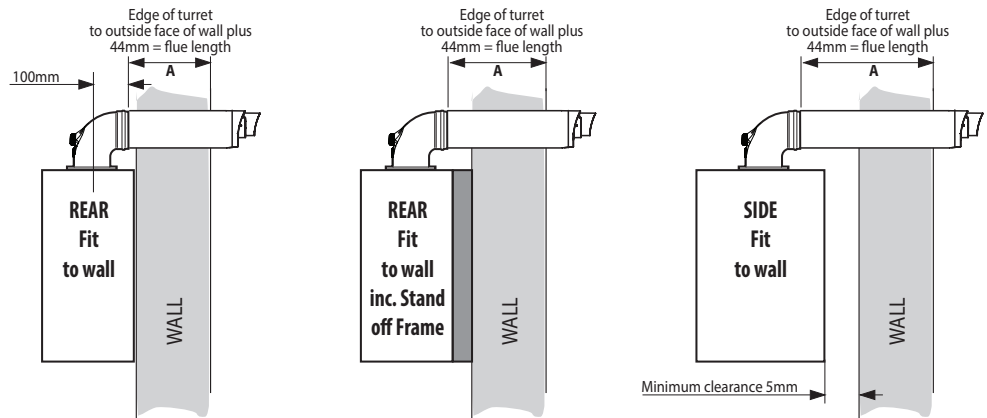

**NOTES**  
 Centre of turret to edge of turret = 100mm  
 Turret has a flue insertion of 30mm  
 The compressed outer wall seal has protruding wall to seal mounting lip - 14mm  
 From centreline of turret to wall. Rear mount 155mm, side (including clearance) 200mm

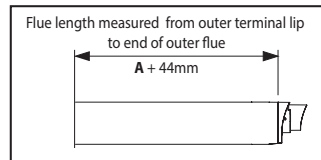

**FIGURE 2**

Shows the flue required when measured from outside edge of turret to the outside face of the wall (to obtain cut length add 44mm)

	Minimum & Maximum finished flue lengths obtainable (dimension 'A' +44mm)							
	horizontal Flue Terminal (600mm long) B pack		Telescopic Flue B pack		horizontal Flue Terminal (1000mm long) B pack (Telescopic)		horizontal Flue Terminal (1000mm long) B pack (Telescopic) Cut 75mm	
	Minimum	Maximum	Minimum	Maximum	Minimum	Maximum	Minimum	Maximum
<b>B pack (standard)</b>	171	556	286	484	601	816	526	741
Plus 1 (1m D pack)	1121	1506	1236	1434	1551	1766	1476	1691
Plus 2 (1m D pack)	2071	2456	2186	2384	2501	2716	2426	2641
Plus 3 (1m D pack)	3021	3406	3136	3334	3451	3666	3376	3591
Plus 4 (1m D pack)	3971	4356	4086	4284	4401	4616	4326	4541
Plus 5 (1m D pack)	4921	5306	5036	5234	5351	5566	5276	5491
Plus 6 (1m D pack)	5871	6256	5986	6184	6301	6516	6226	6441
Plus 7 (1m D pack)	6821	7206	6936	7134	7251	7466	7176	7391
Plus 8 (1m D pack)	7771	8156	7886	8084	8201	8416	8126	8341
Plus 9 (1m D pack)	8721	9000	8836	9000	9000	9000	9000	9000

Max output 30 kW  
Max output 12, 15, 18, 24 kW

Note; Telescopic flue B Pack or attached "D" pack extensions do not need to be cut between minimum and maximum values shown above (except where specified). Horizontal Flue Terminal (600mm long) B Pack flue will require cutting on values below maximum values shown in the table above.

## 21 CUTTING & sETTING ThE FLUE LENgTh

### TELEsCOPIc FLUEs

**TELEsCOPIc FLUE B paCK** SHOULD ONLY BE ADJUSTED FOR USE WITHIN ITS SPECIFIED RANGE AND MUST NOT BE CUT

**hORizONTaL FLUE TERMINaL (1000MM LONG) B paCK (TELEsCOPIc)** MUST ONLY BE CUT IF REQUIRED FLUE LENGTHS ARE BETWEEN **602 & 652MM**. THIS WILL REQUIRE 75MM TO BE CUT OFF THE TERMINAL END OF THE 1000MM TELESCOPIC FLUE.

ALL OTHER LENGTHS OBTAINED USING "D" PACK EXTENSIONS IN FLUE LENGTH TABLE 1, COLUMN "HORIZONTAL FLUE TERMINAL (1000MM LONG) B PACK CUT 75MM" (TELESCOPIC) SHOULD HAVE THE 75MM CUT OFF THE "D" PACK EXTENSION AND NOT TELESCOPIC FLUE

### CUT 75MM OFF hORizONTaL FLUE TERMINaL 1000MM LONG B paCK (TELEsCOPIc)

1. Measure cut flue length (A+44mm). (If required telescopic length is not between 658 and 708 then proceed to "Setting Telescopic Flue B Pack").
2. Remove telescopic end piece from the flue body and set aside.
3. Mark the circumference 75mm from the open end of the outer flue.
4. Cut along the 75mm mark cutting **only the outer flue** ensuring the cut is square.
5. Dress the cut end to make sure all burr is removed and the cut edge is in its original shape.
6. Measure 20mm from the newly cut edge of the outer flue, place a mark at the top of the flue approximately 20mm wide & write stop the terminal side of the line.
7. Mark the inner tube 10mm longer than the outer tube around its circumference and cut following the mark to ensure its cut square
8. Remove all burrs and place a chamfer on the outer edge to aid assembly.
9. Re-assemble telescopic section.

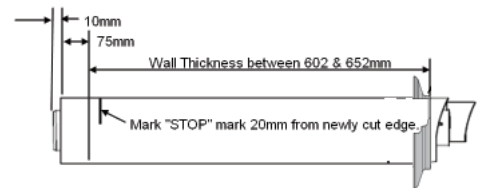

### sETTING TELEsCOPIc FLUE B p aCK

1. Measure the required flue length (A+44mm).
2. Measure from the outer terminal lip to end of outer flue. Pull apart flue until desired length is achieved. ENSURE THE STOP MARK IS NOT VISIBLE, IF IT IS, THE FLUE IS TOO SHORT AND SHOULD NOT BE USED.
3. Check that both flue seams are at the top and the outlet terminal is upper most.
4. Drill a 3.5mm hole through one of the 2 outer side holes in the outer flue section into the inserted outer flue (as shown). Take care not to pierce the inner plastic flue. Fit screw provided.
5. Seal the joint on the outer air duct with the tape provided.
6. Fit internal and external wall seals (see installing flue)

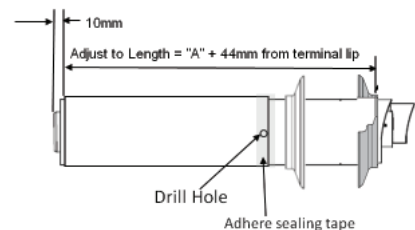

### CUTTING hORizONTaL FLUE TERMINaL (600MM LONG) B paCK

1. Measure the required cut flue length (A+44mm). If inside the dimensions shown in Figure 2 "1 Piece 600mm" proceed.
2. Measure from the outer terminal lip to end of outer flue. Mark the required cut length (A+44) around the circumference of the outer flue and cut following the mark to ensure its cut square.
3. Dress the cut end to make sure all burr's are removed and the cut edge is in its original shape.
4. Mark the inner tube 10mm longer than the outer tube around its circumference and cut following the mark to ensure its cut square.
5. Remove all burrs and place a light chamfer on the outer edge to aid assembly.

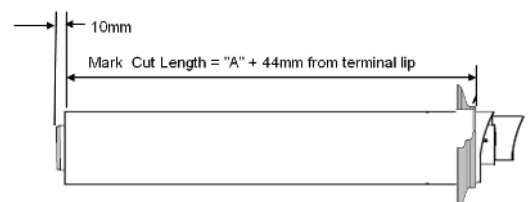

## 22 INsTaLLING THE FLUE

### FITTING FLUE THROUGH THE WALL

1. Measure wall thickness and add 14mm.
2. Measure from the outer terminal lip towards the end of outer flue, place a small location mark at the dimension acquired at point 1.
3. Add a further 14mm to the dimension, obtain at item 1 (point 1) and place an additional small location mark.
4. Fit external black wall seal ensuring the inside of the outer lip is in contact with the terminal lip you have been measuring from (see fig 1)
5. Fit the internal wall seal approximately 65mm before the outer of the 2 location marks.
6. For an internal fit place flue terminal in the centre of the 5" drilled hole in the wall. Apply pressure and lightly move the flue left to right or up and down. This will cause the outer flange to fold in and allow the flue to pass through the wall.
7. Push through a further 65mm or until the inner flange is pressed against the inner wall. This will allow the outer flange to return to its original shape.
8. Pull back the flue until the first of the 2 location marks is level with the internal face of the wall.

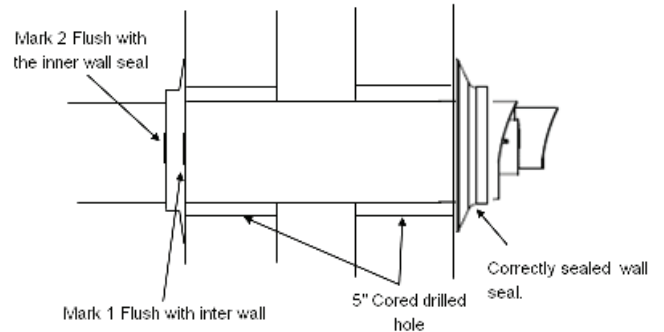
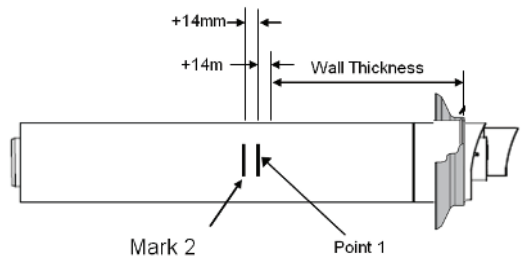

*Note. If the 2 location marks are not visible then the flue is not pulled back far enough to obtain the correct seal. If the 1st location mark has passed the face of the wall the flue has been pulled to far back and the outer wall seal will have been dislodged from its mounting and will need to be refitted.*

9. When 1st mark is in line with the wall, whilst holding the flue firmly, push the white wall sealing flange to the wall until the 2nd of the two marks is just visible. If the last location mark is clearly passed the white inner wall seal then the outer wall seal will have been dislodged from its mounting and will need to be re-fitted.
10. Ensure the seam and the outlet terminal are at the top and fitted as shown.

*Note. If less than 50% of the length of the flue is internal the flue should be fitted from outside.*

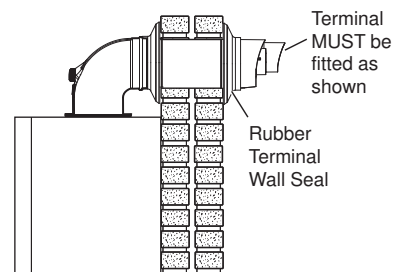
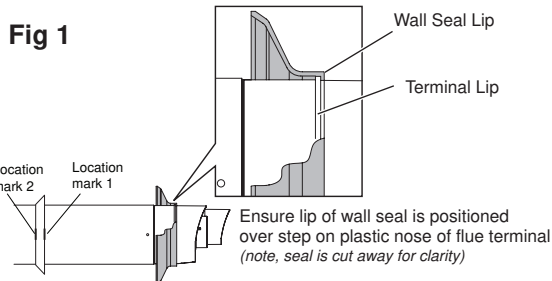

### FITTING THE TURRET

1. Ensure the rubber seal is fitted correctly on the appliance manifold and that all flue seals are undamaged.
2. Hold the flue firmly and push the turret on until it has travelled 30mm on to the flue pipe and is fully engaged. Make sure the flue has not rotated or moved forward during fitting and the flue seam is upper most.
3. Push the turret into the manifold ensuring the upper plastic lip is flush with the top of the manifold.
4. Fully engage the clamp location section into the manifold location holes. Rotate down on to turret flange.
5. Secure clamp to appliance using securing screw.
6. Ensure all sample points are accessible and all sample plugs and caps are fitted.

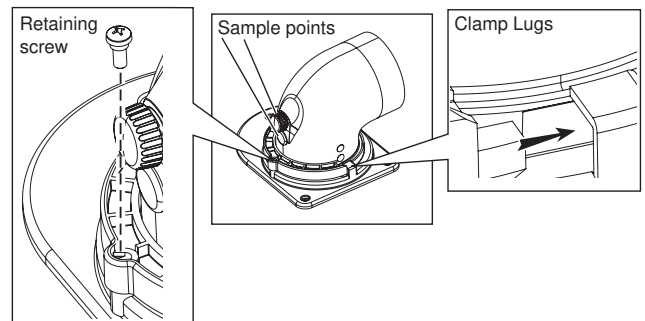
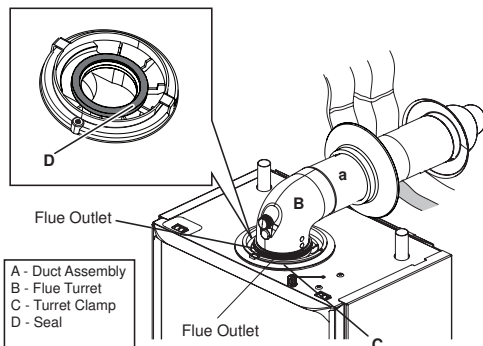

## 23 REAR FLUE OUTLET KIT (55/80) ASSEMBLY - EXPLODED VIEW

### LEgEND

1. Duct Assembly
2. Plastic Connector
3. Wall Mounting Plate

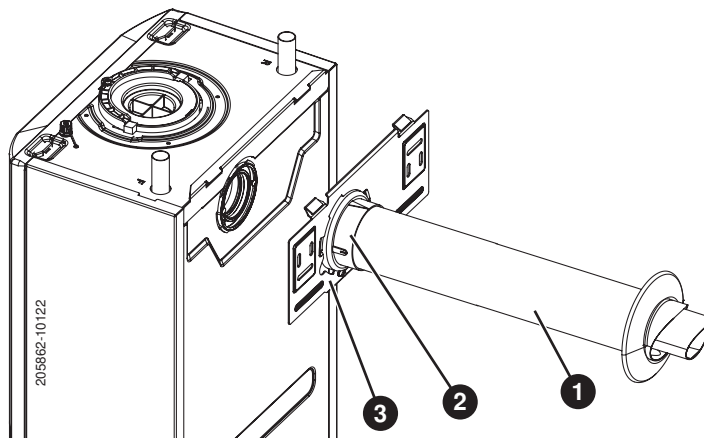

## 24 TERMINAL WALL SEAL ASSEMBLY/POSITIONING

Prior to fitting the flue, the rubber terminal wall seal provided in the flue pack **MUST** be fitted to the flue terminal as shown below in Figure 1.

Once the flue is installed it is **IMPORTANT** that the rubber terminal wall seal is pressed against the outside wall to create an adequate seal between the flue and wall as shown in Figure 2.

**FIGURE 1**

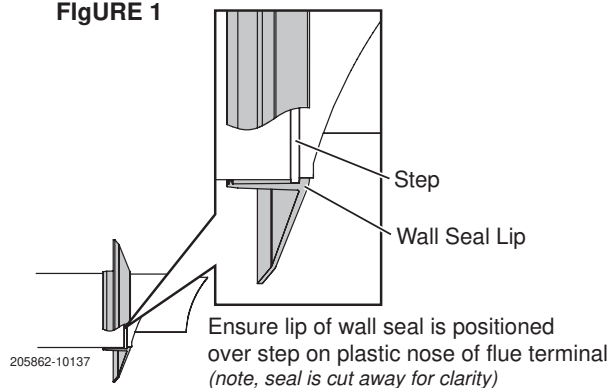

**FIGURE 2**

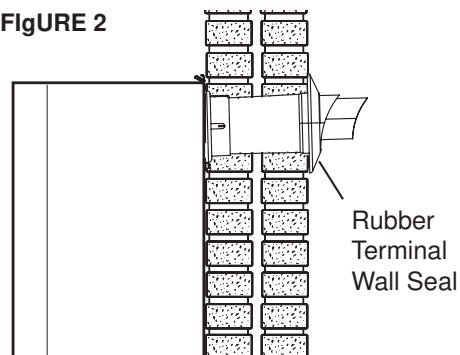

## 25 SETTING THE REAR FLUE LENGTH - WALL THICKNESS OF 115MM TO 442 MM

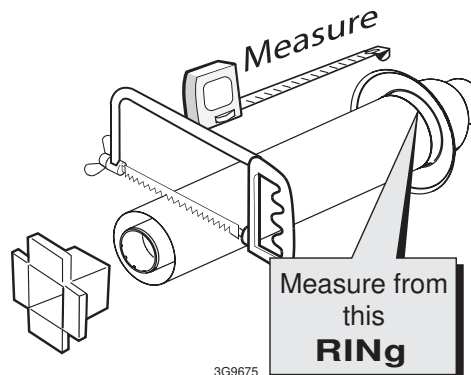
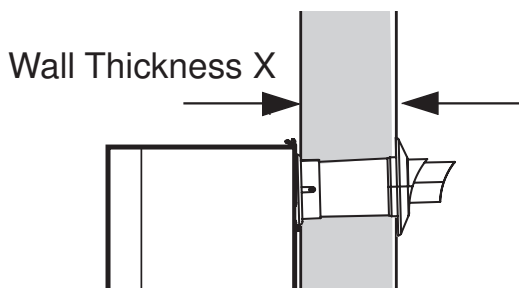

1. Measure and note wall thickness X. Refer to Frame 13.
2. Add 8mm to dimension X and, measuring from the ring, cut the outer tube only.
3. To ensure the tube is cut square, mark the flue all the way around.
4. Cut the inner tube to a length 10mm longer to aid engagement, using the cutting aid provided.

**Note.** If the stand-off frame is used, it is essential to add 45mm to 'X' the measured wall thickness when marking the flue (this will allow for the fitted frame)

## 26 FITTING THE WALL PLATE/REAR FLUE TERMINAL ASSEMBLY

1. Ensure the rubber terminal wall seal is fitted to the terminal. Refer to Frame 28.
2. Insert the previously cut to length terminal assembly into the plastic connector.
3. Line up the mark on the top of the plastic connector with the top of the terminal (marked with a label).
4. Drill 2 - 3.5mm dia holes through each side of the plastic connector and the air duct and fit the two self tapping screws (provided) to retain the duct terminal assembly to the plastic connector.
5. Seal the joint between the plastic connector and the terminal air duct with the tape provided.
6. Push the terminal assembly through the prepared hole in the wall until the rubber seal clears the outside wall. Rest the assembly in the hole while fitting the wall mounting plate.
7. Screw the wall mounting plate to the wall using 2 wall plugs (previously fitted) with the 2 screws provided. Choose one of the 2 sets of slots in the left and right bank. Ensure that at least one of the screws is fitted into a top slot.
8. Pull the flue assembly back through the wall mounting plate to seal against the outside wall face and ensure the 3 locating tabs are pulled through the wall mounting plate slots.
9. Turn the plastic connector clockwise to lock the connector into the wall plate.
10. Retain with the M5 screws provided.

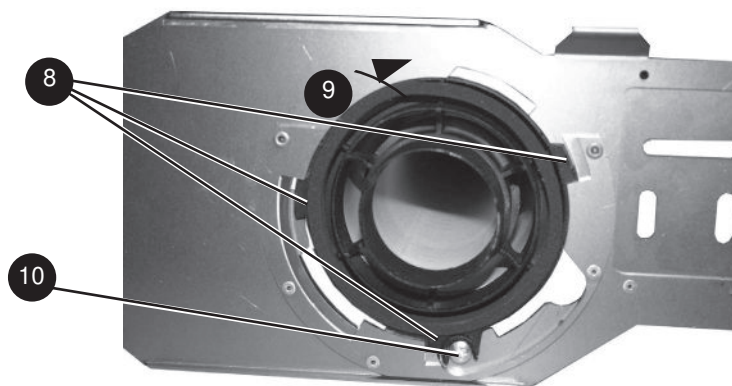
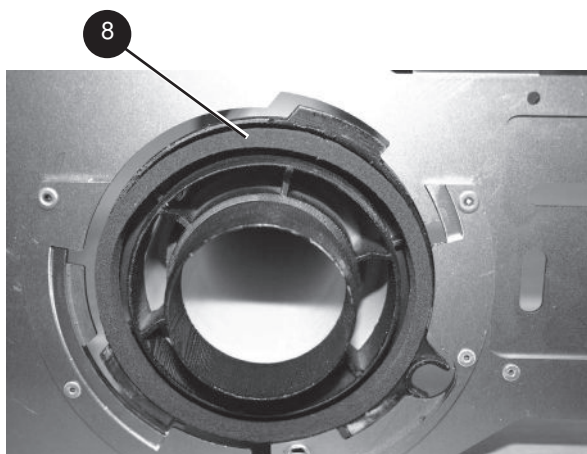
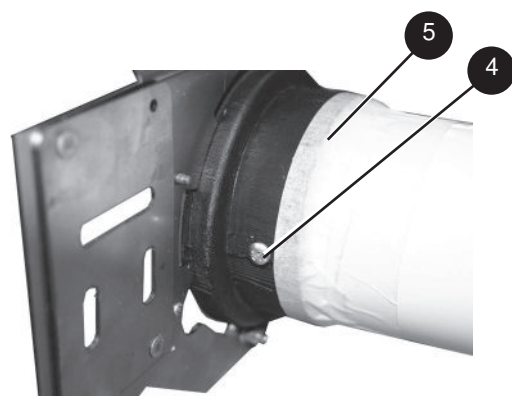

## 27 MOUNTING THE BOILER - REAR FLUE OUTLET KIT (55/80)

1. Remove the rear flue blanking disk.
2. Lift the boiler onto the wall plate, (refer to the introduction section for safe handling advice), ensuring the boiler is offered to the bracket tabs at an angle as shown below, and carefully allow the boiler to swing down to the wall as this movement engages the rear flue air and flue seal.
3. Screw the boiler bottom retaining bracket to the wall with the screw provided.
4. Remove the top flue blanking disk refer to Frame 26. Fill the condensate trap within the boiler by pouring a cupful of water into the flue outlet. Take care to ensure that the water is only poured into the flue outlet, and does not spill into the boiler casing.
5. Replace the top flue blanking disc and retain with the horseshoe bracket and fixing screw previously removed.

During assembly check that the flue seals do not become dislodged.

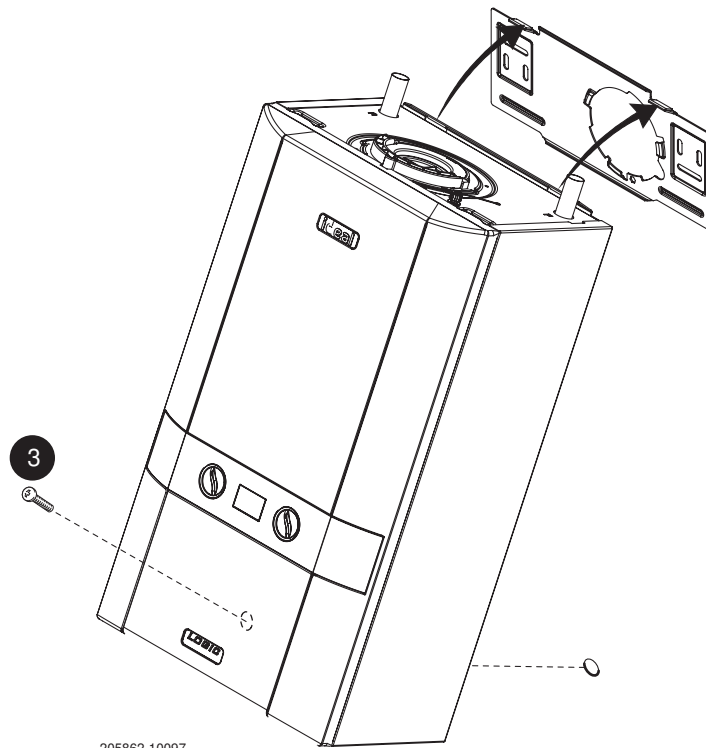
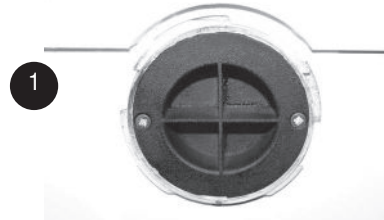

205862-10097

## 28 FITTING THE OPTIONAL ROOF FLUE KIT (Flat or pitched)

### Note.

A flat or pitched roof flashing plate (not supplied) is required before proceeding with the installation of this kit.

This kit is suitable for both flat and pitched roof terminations, using a concentric flue to run vertically from the top of the boiler and terminating above roof level.

Connection to the top of the boiler is made using a separately supplied vertical connector.

### WEATHER PROOFING

Where the flue passes through the roof line an adequate seal must be made. This is achieved by using either:

- Flat roof weather collar
- or
- Universal weather collar.

### ACCESSORIES

Flue Duct Extension Kits are available for flue lengths extending beyond 1m. These packs contain 1m extension ducts and may be cut to the desired length.

If the offset vertical option is used an elbow Kit is required. For a full accessories list refer to page 6, Optional Extras.

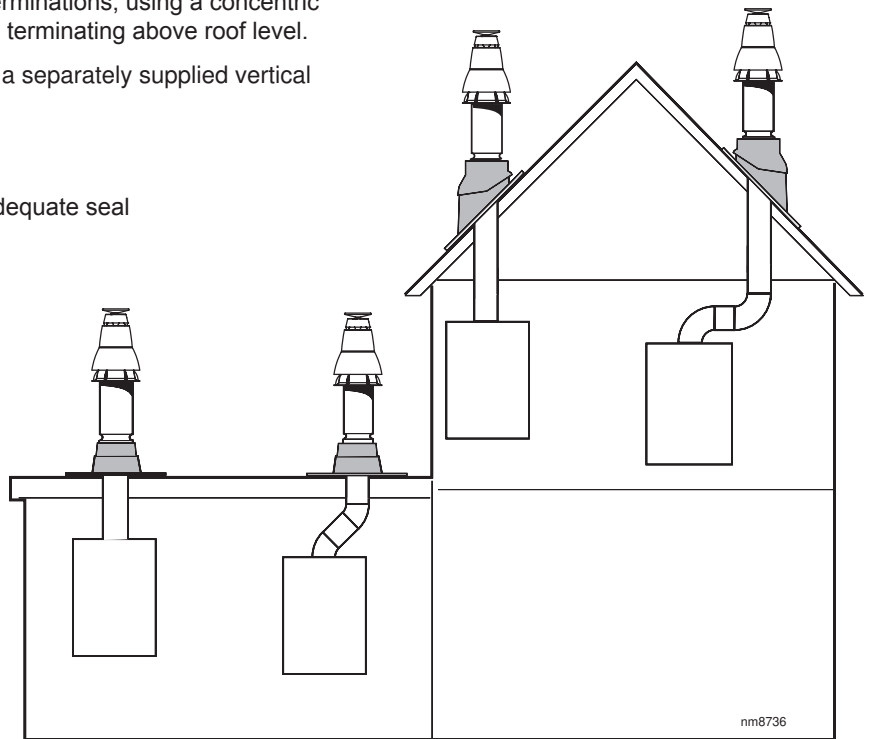

nm8736

## 29 ROOF FLUE KIT CONTENTS / OPTIONS

Flue Terminal  
UIN 203132

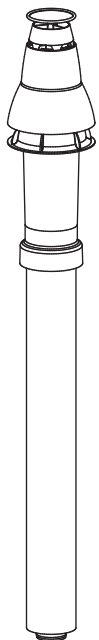

Flue seal Collar - Flat Roof  
UIN 152259

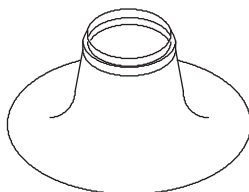

Vertical connector  
UIN 208175



90° elbow  
UIN 203130



45° elbow  
UIN 203131

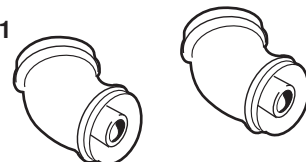

Flue seal Collar - Tile Roof  
UIN 152258

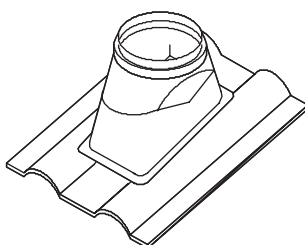

Roof Flue Extension Duct  
UIN 203129

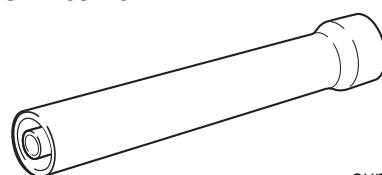

Flue duct support



Flue duct support

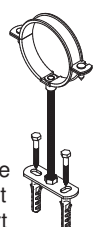

### 30 FLUE TERMINAL pOsITION

The terminal should be positioned so that products of combustion can safely disperse at all times.

plumbing may occur at the termination so, where possible, terminal positions where this could cause a nuisance should be avoided.

Minimum dimensions are shown below

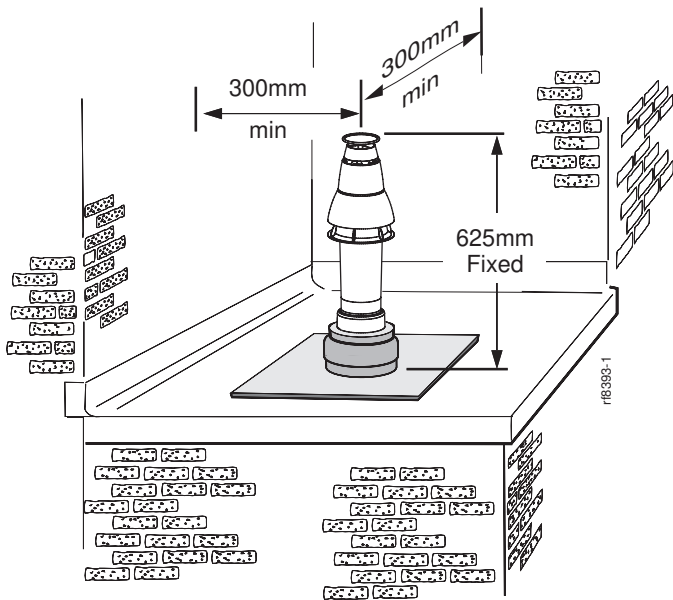
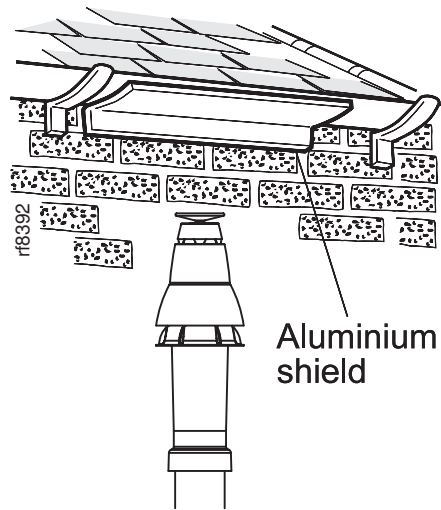

Flat roof - with structure

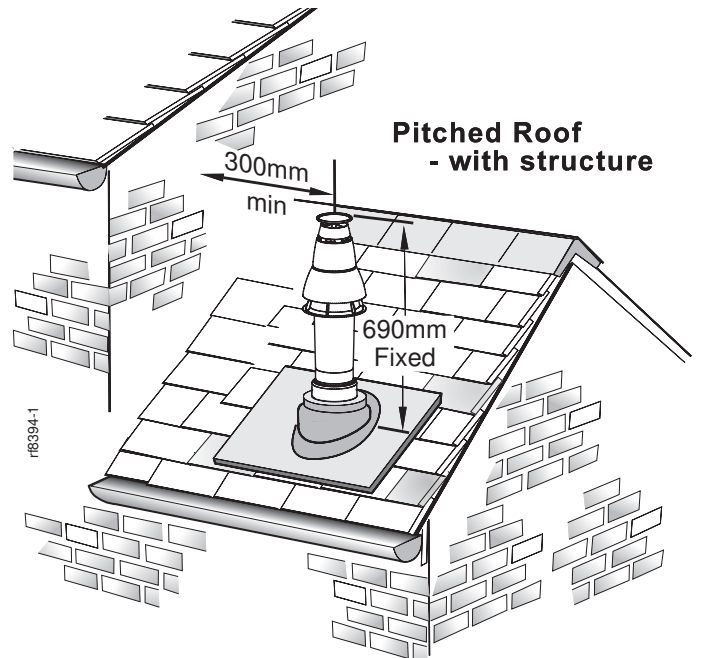

Pitched Roof - with structure

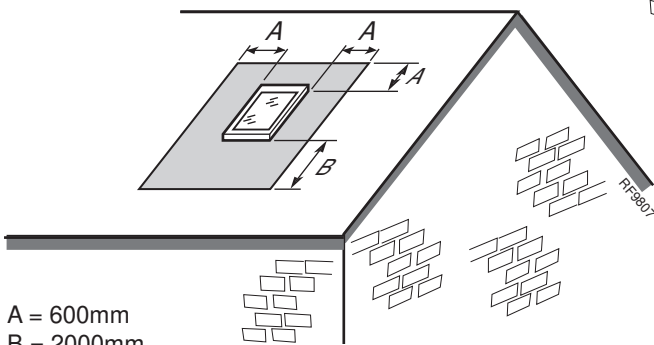

A = 600mm  
B = 2000mm

The flue terminal shall not penetrate the shaded area of the roof

Terminal position	Minimum Dimension
Directly below an opening, air brick, windows, etc.	300 mm
Below plastic / painted gutters	300 mm
Painted surface	300 mm
Below eaves or balcony	500 mm
Below velux windows	2000mm
Above or side of velux windows	600mm

**Note.**

The equivalent flue length resistance of the elbow kits are:  
90° elbow kit = 1m  
45° elbow kit = 0.6m

## 31 assEMBLING ThE ROOF FLUE KIT

Determine the correct height that the flue should terminate above the roof. If after calculating or measuring the overall flue height from the top of the boiler, it is necessary to cut both pipes of assembly A, then ensure they are cut equally leaving the inner flue tube longer than the outer air tube as supplied.

Ensure the cut pipe ends are free from any burrs.

1. Position the roof flashing plate (supplied separately) over the hole cut in the roof and insert flue terminal from the roof end.
2. Fit the vertical connector (supplied separately) in accordance with the instructions provided with the vertical connector kit.

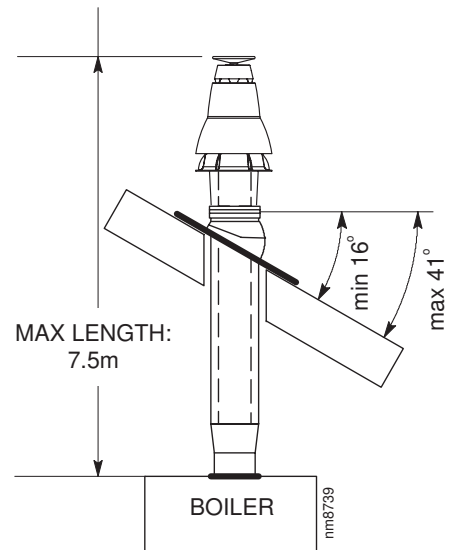
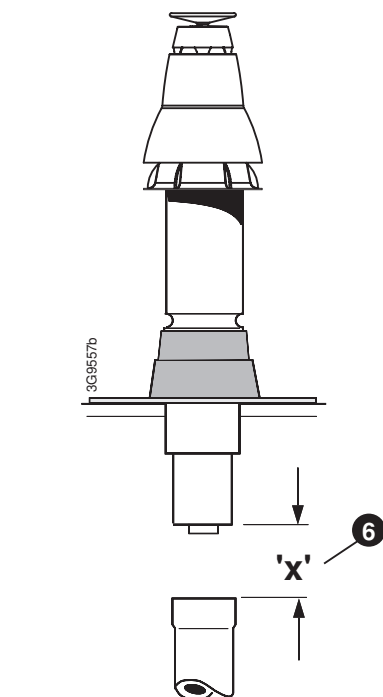
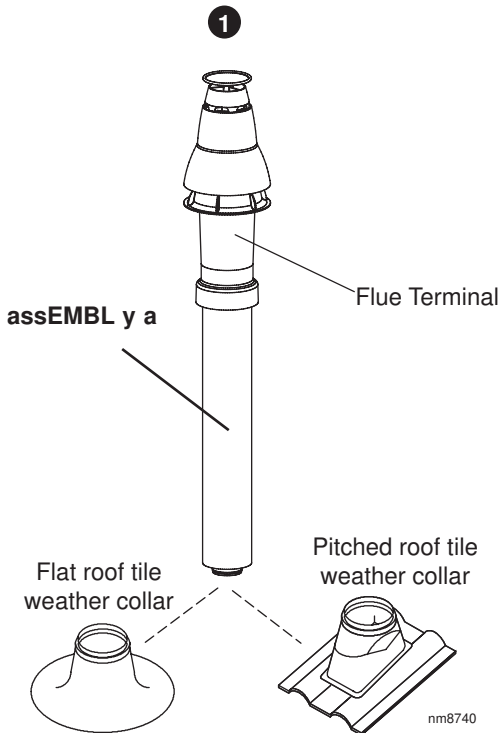

3. Secure the vertical connector by applying downward pressure on the connector.
4. Position the clamp on the top face of the flue manifold and push it horizontally backwards. Locate both clamp lugs into the flue manifold and secure to the flue manifold with the M5 retaining screw.
5. "Push" fit extension duct (if required (supplied separately)) into vertical connector.

**Note.** Ensure turret sample points are servicable and all caps and plugs are fitted.

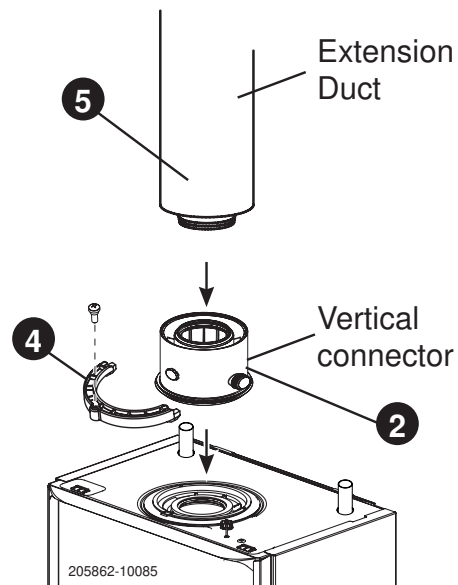

6. If the last extension duct requires cutting, measure 'X', the distance (outer ducts), between the duct and the terminal and add 100 mm to this dimension. This gives the length of the last extension duct.

**Note.** Check the position of the inner flue duct relative to the outer duct on the assembled extension duct(s) and ensure the terminal flue duct is cut longer than the air duct to ensure engagement in the final flue duct seal.

7. Finally ensure the roof flashing plate is correctly sealed to the roof.

32 CONDENSa TE DRaIn

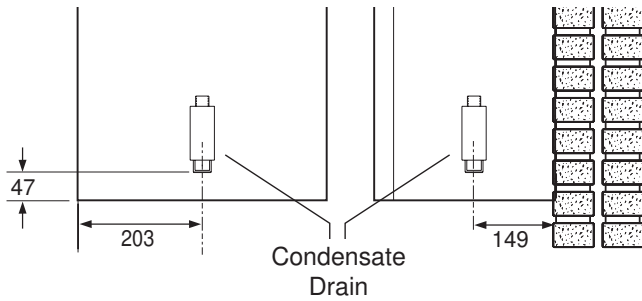

This appliance is fitted with a siphonic 75mm condensate trap system that requires filling before operating the appliance for the 1st time or after maintenance.

All condensate pipework should conform to the following:

- Where a new or replacement boiler is being installed, access to an internal 'gravity discharge' termination should be one of the main factors considered in determining boiler location.
- Plastic with push fit or solvent connections.
- Internal plastic pipe work a minimum of 19mm ID (typically 22mm OD)
- External plastic pipe must be a minimum of 30mm ID (typically 32 OD) before it passes through the sleeved wall.
- All horizontal pipe runs, must fall a minimum of 45mm per metre away from the Boiler.
- External & unheated pipe work should be kept to a minimum and insulated with Class "O" waterproof pipe insulation.
- All installations must be carried out in accordance to the relevant connection methods as shown in the "Condensate installation diagrams" & BS6798:2009
- Pipe work must be installed so that it does not allow spillage into the dwelling in the event of a blockage (through freezing)
- All internal burrs should be removed from the pipe work and any fittings.

In order to minimise the risk of freezing during prolonged very cold spells, one of the following methods of terminating condensate drainage pipe should be adopted.

**Internal Drain Connections**

Wherever possible, the condensate drainage pipe should be routed to drain by gravity to a suitable internal foul water discharge point such as an internal soil and vent stack or kitchen or bathroom waste pipe etc. See Figs 1 and 2.

**Condensate pump**

Where gravity discharge to an internal termination is not physically possible or where very long internal pipe runs would be required to reach a suitable discharge point, a condensate pump of a specification recommended by the boiler or pump manufacturer should be used terminating into a suitable internal foul water discharge point such as an internal soil and vent stack or internal kitchen or bathroom waste pipe etc. (fig 3).

**External Drain Connections**

The use of an externally run condensate drainage pipe should only be considered after exhausting all internal termination options as described previously. An external system must terminate at a suitable foul water discharge point or purpose designed soak away. If an external system is chosen then the following measures must be adopted:

The external pipe run should be kept to a minimum using the most direct and "most vertical" route possible to the discharge point, with no horizontal sections in which condensate might collect.

- For connections to an external soil/vent stack see Fig 4. Insulation measures as described should be used.
- When a rainwater downpipe is used, an air break must be installed between the condensate drainage pipe and the downpipe to avoid reverse flow of rainwater into the boiler should the downpipe become flooded or frozen, see Fig 5.
- Where the condensate drain pipe terminates over an open foul drain or gully, the pipe should terminate below the grating level, but above water level, to minimise "wind chill" at the open end. The use of a drain cover (as used to prevent blockage by leaves) may offer further prevention from wind chill. See Fig 6.
- Where the condensate drain pipe terminates in a purpose designed soak away (see BS 6798) any above ground condensate drain pipe sections should be run and insulated as described above. See Fig 7

**Unheated Internal areas**

Internal condensate drain pipes run in unheated areas, e.g. lofts basements and garages, should be treated as external pipe.

Ensure the customer is aware of the effects created by a frozen condensate and is shown where this information can be found in the user manual.

**Figure 1** - Connection of Condensate Drainage Pipe to Internal Soil & Vent Stack

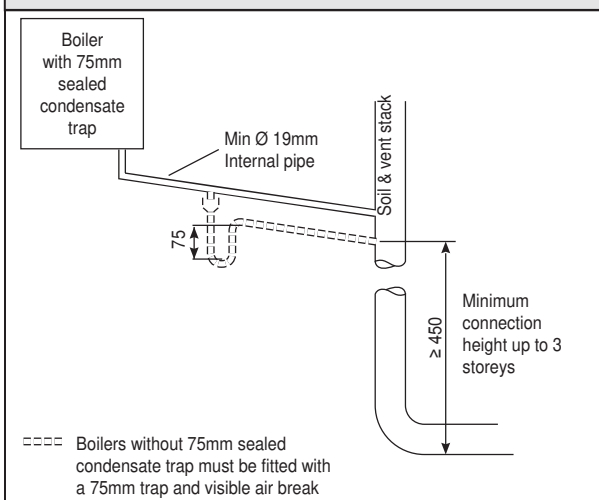

**Figure 2** - Connection of a Condensate Drainage Pipe Downstream of a Sink, Basin, Bath or Shower Water Trap to Internal Soil Vent Stack

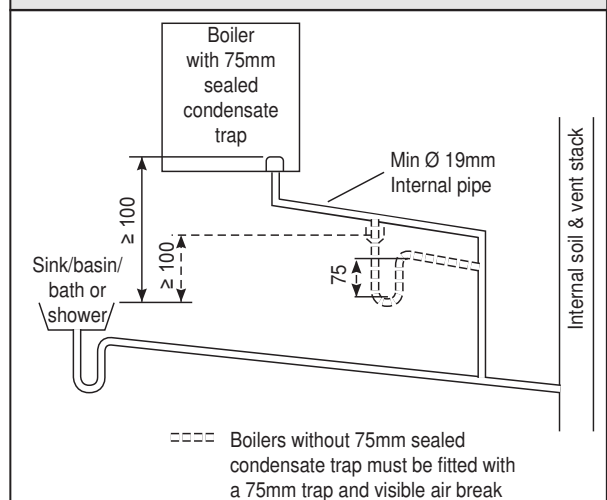

continued . . . . .

33 CONDENSa TE DRaIn - CONT'D.....

**Figure 3** - Connection of a Condensate Pump Typical Method (see manufacturers detailed instructions)

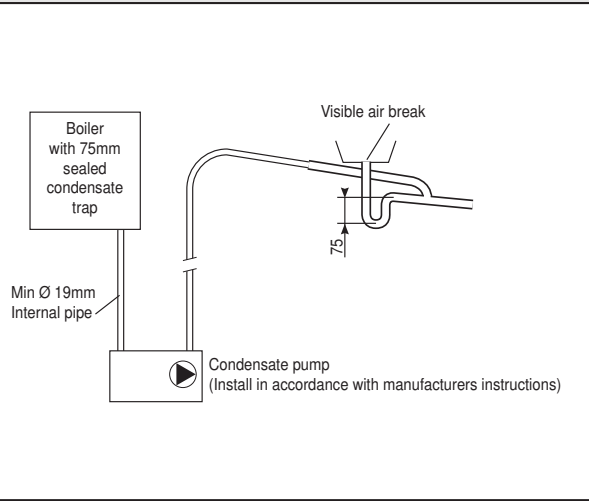

**Figure 4** - Connection of condensate Drainage Pipe to External Soil & Vent Stack

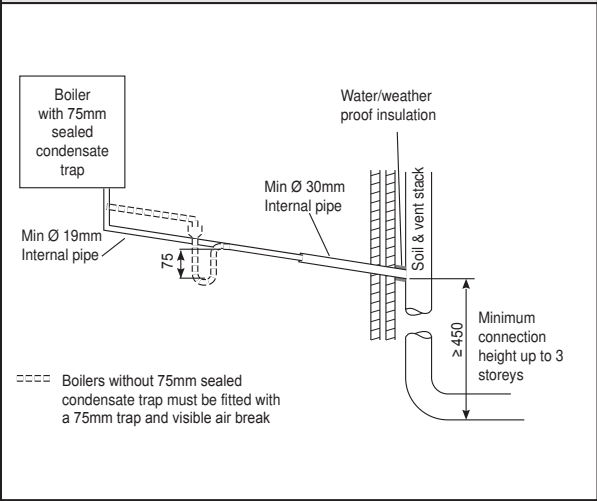

**Figure 5** - Connection of a Condensate Drainage Pipe to an External Rainwater Downpipe (only combined foul/rainwater drain)

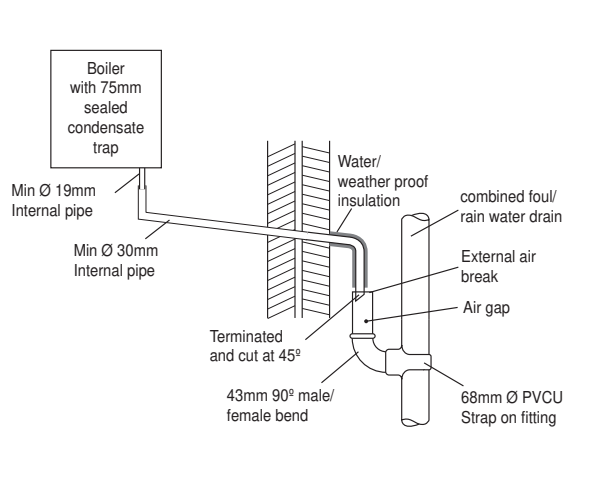

**Figure 6** - Connection of Condensate Drainage Pipe Upstream of a Sink, Basin, Bath or Shower Waste Trap to External Drain, Gully or Ranwater Hopper

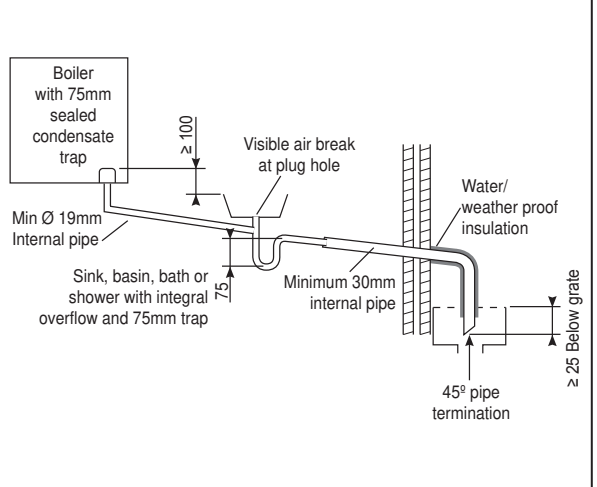

**Figure 7** - Connection of a Condensate Drainage Pipe to an External Purpose Made Soak Away.

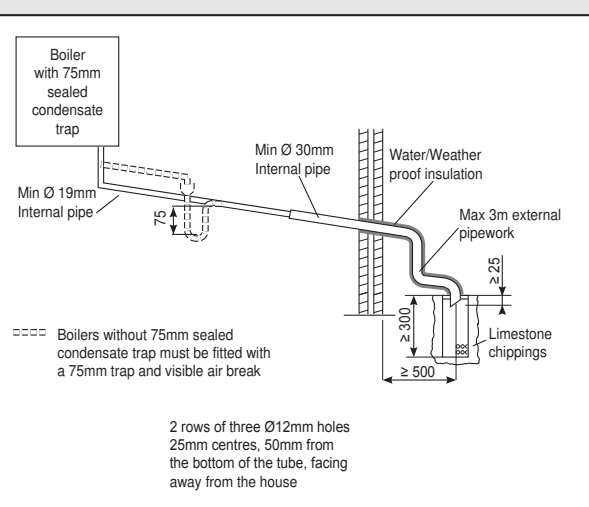

## 34 CONNECTIONS

### NOTES.

Ensure all pipe blanking plugs are removed before connecting.

### WaTER CONNECTIONS

The boiler flow and return pipes are supplied fitted to the boiler and ready for top connection.

**note.** For heating loads in excess of 17.6kW (60,000 Btu/h) use 28mm x 22mm connectors to connect the boiler flow and return pipes to 28mm.

### Top Connection

Connect the system pipework to the boiler flow and return pipes.

An optional stand-off kit is available where system pipework needs to be taken downwards.

### gas CONNECTION

**IMpORTaNT.** The gas service cock is sealed with a non-metallic blue fibre washer, which must not be overheated when making capillary connections. Refer to Frame 1 for details of the position of the gas connection.

For additional gas supply information refer to "Gas Supply" on page 8.

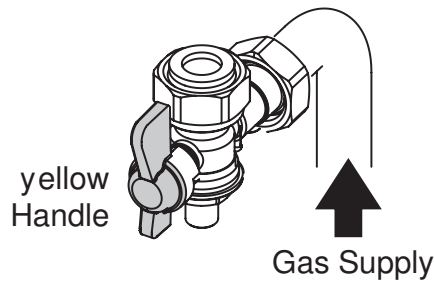
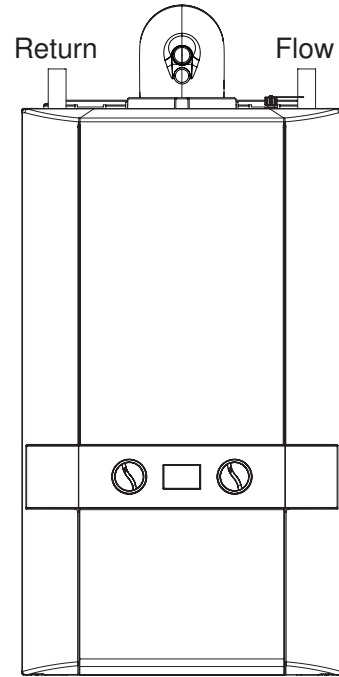

Note. The gas isolation handle is shown in the open position.

205862-10073

## 35 ELECTRICAL CONNECTIONS

**Warning.** This appliance MUST be earthed.

A mains supply of 230Vac ~ 50 Hz is required.

The fuse rating should be 3A. All external controls and wiring must be suitable for mains voltage.

Wiring external to the boiler MUST be in accordance with the current I.E.E. (BS.7671) Wiring Regulations and any local regulations.

Wiring should be 3 core PVC insulated cable, not less than 0.75mm<sup>2</sup> (24 x 0.2mm), and to BS 6500 Table 16. For IE reference should be made to the current ETCI rules for electrical installations.

The mains supply to the boiler and system wiring centre shall be through one common fused double pole isolator. For heating systems, and where practicable replacement boiler installations, the isolator shall be situated adjacent to the appliance.

**noTe.** The appliance must be wired with a permanent live supply. The system pump must be wired to the boiler (see Frame 41). The boiler warranty will be invalid if this requirement is not complied with.

### 36 INTERNaL INStALLER WIRING

The Logic Heat boiler must be connected to a permanent live supply and NOT switched by thermostats/programmers.

**To install the mains cable:**

1. Isolate the mains supply to the boiler.
2. Remove the front panel. Refer to Frame 12.
3. Swing the control box down into the servicing position.
4. Route incoming cable through a grommet in the bottom panel (note that the grommets are "blind" and will require puncturing) and secure using the clamp and screws provided in the hardware pack.
5. Connect the mains cable to the terminal block as shown.

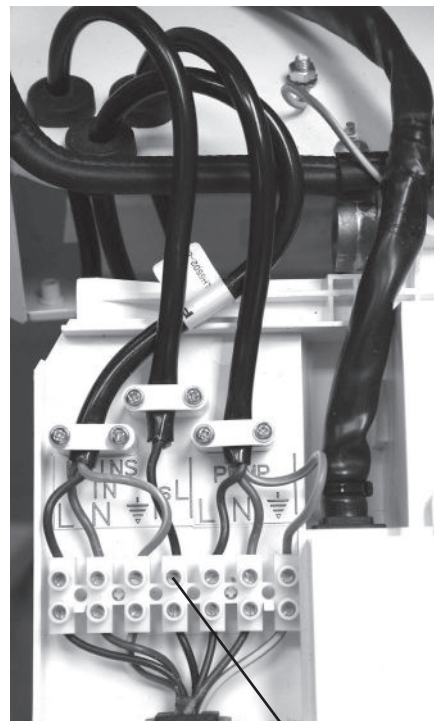

**Connecting the Switched Live to the Boiler**

1. Consult the y Plan and S Plan diagrams below.
2. Isolate the mains supply to the boiler
3. Remove the front panel. Refer to Frame 12.
4. Swing the control box down into the servicing position.
5. Route incoming cable through a grommet in the bottom panel (note that the grommets are "blind" and will require puncturing) and secure using the clamp and screws provided in the hardware pack.
6. Connect the switched live to the terminal block as shown.

**Frost Thermostat - Wiring**

If parts of the system are vulnerable to freezing or the programmer is likely to be left off during cold weather, a frost stat should be fitted in conjunction with a pipe thermostat.

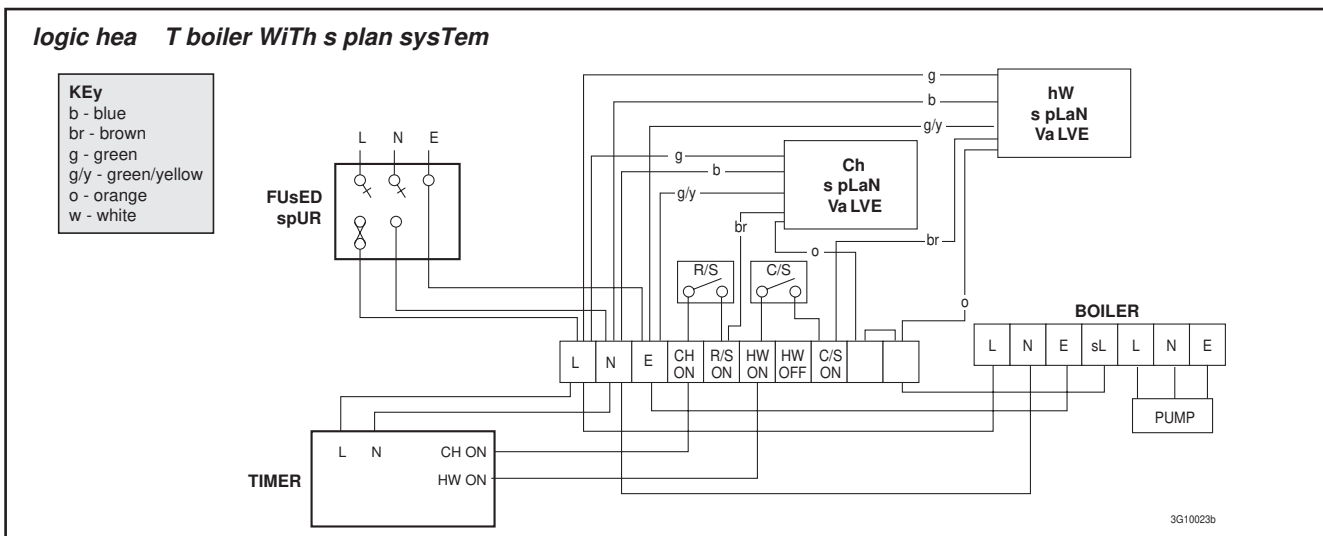
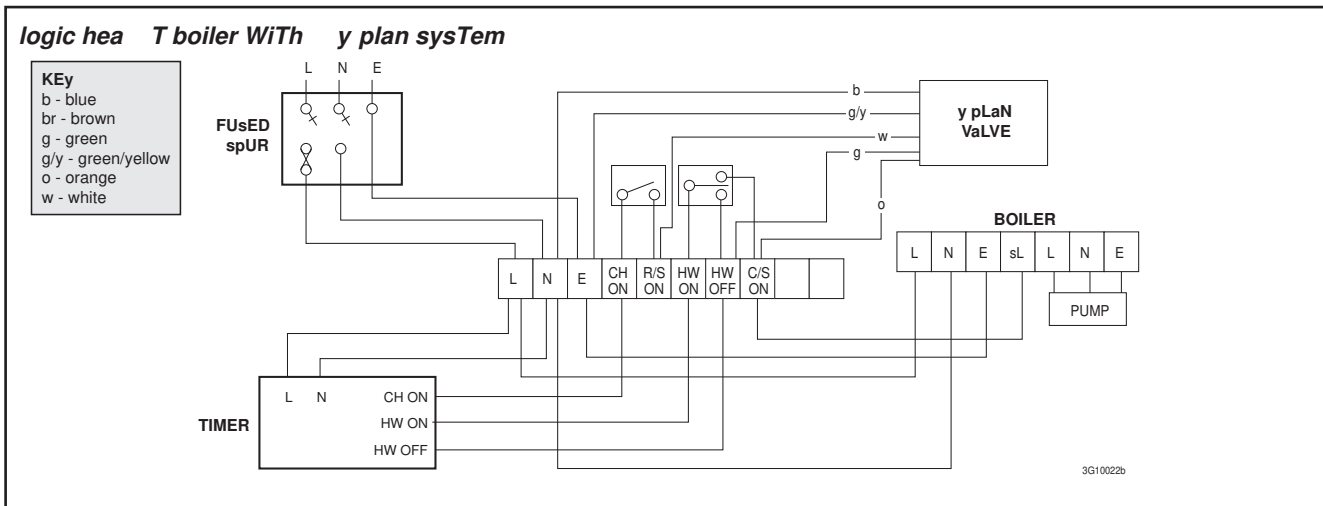

## 37 WIRING THE SYSTEM pUMp

**note.** The appliance must be wired with a permanent live supply. The system pump must be wired to the boiler. The boiler warranty will be invalid if this requirement is not complied with.

1. Isolate the mains supply to the boiler.
2. Remove the front panel. Refer to Frame 12.
3. Swing the control box down into the service position.
4. Loosen the pump wire cable clamp.
5. Route pump cable through the cable clamp and grommet and re-tighten to provide cord anchorage.
6. Connect the live, neutral and earth wires to the terminal strip. When making the mains electrical connections to the boiler it is important that the wires are prepared in such a way that the earth conductor is longer than the current carrying conductors, such that if the cord anchorage should slip, the current carrying conductors become taut before the earthing conductor.
7. Swing the control box back up into the operating position and re-fit the front panel ensuring a good seal is made.

**note.**

For multiple boiler installations with a common pump, the pump connection should be made directly from each boiler to the same pump, as long as all the boilers are on the same phase.

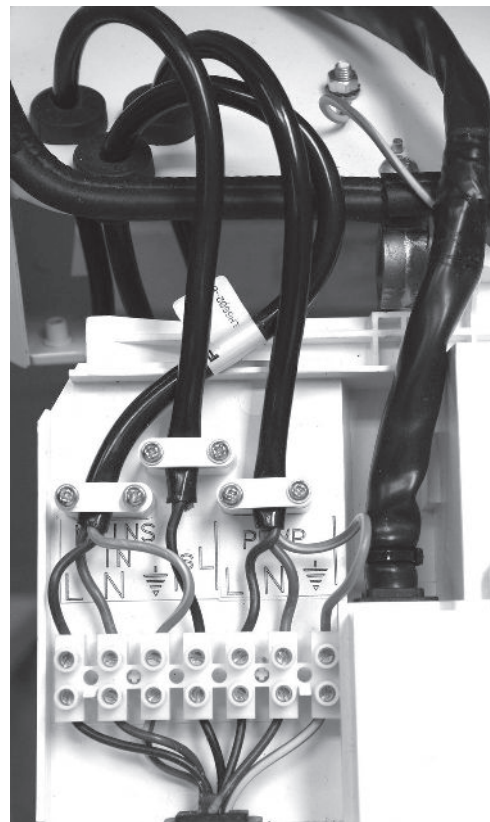

## 38 EXTERNAL ELECTRICAL CONTROLS

### Wiring External to the Boiler

The fuse rating should be 3A.

Wiring external to the boiler MUST be in accordance with the current I.E.E. (BS.7671) Wiring Regulations and any local regulations.

Difficulty in wiring should not arise, providing the following directions are observed:

1. The appliance must be wired with a permanent live supply. External controls should NOT be wired in series with this mains input. Controlling the mains input in this way will prevent the pump overrun sequence and may cause damage to the heat exchanger.
2. 230V AC output is provided and must be used for the system pump. Care must be taken to ensure that the earth conductor is longer than the current carrying conductors for reasons given in Frame 41 - item 6.

### Frost protection

If parts of the pipework run outside the house or if the boiler will be left off for more than a day or so then a frost thermostat should be wired into the system.

The frost thermostat should be sited in a cold place but where it can sense heat from the system.

**Note.** If the boiler is installed in a garage it may be necessary to fit a pipe thermostat, preferably on the return pipework.

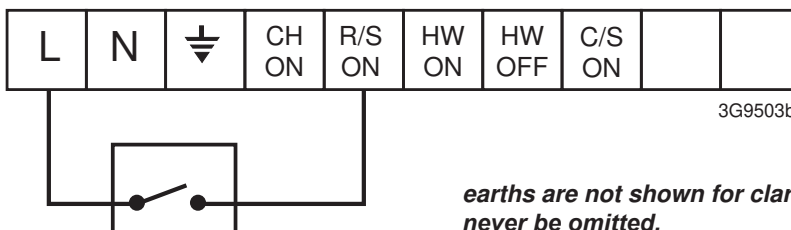

**earths are not shown for clarity but must never be omitted.**

39 WIRING DiagRAM

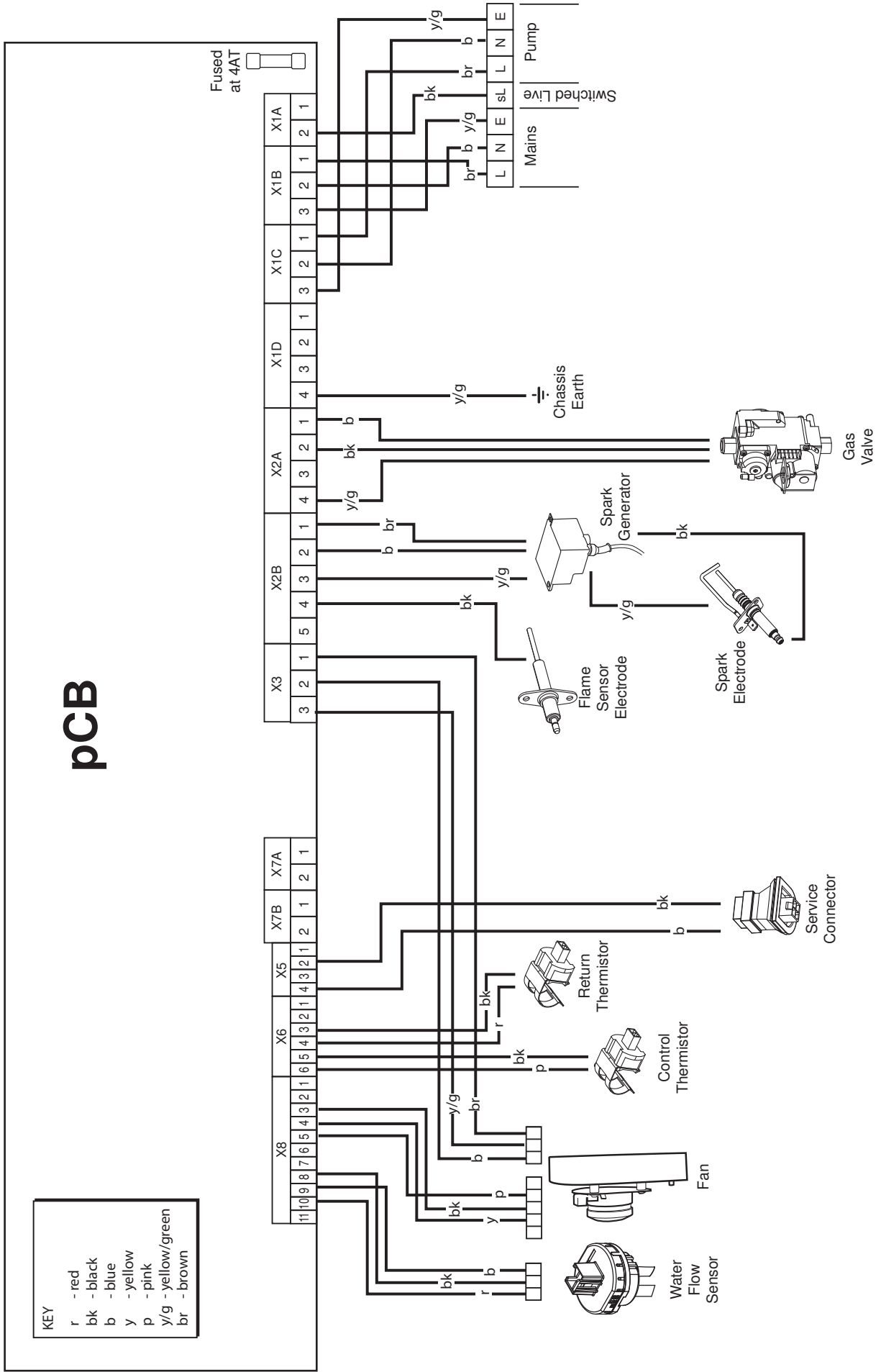

KEY

r	- red
bk	- black
b	- blue
y	- yellow
p	- pink
y/g	- yellow/green
br	- brown

205862-10075b

## 40 COMMISSIONING AND TESTING

### a. Electrical Installation

1. Checks to ensure electrical safety should be carried out by a competent person.
2. ALWAYS carry out the preliminary electrical system checks, i.e. earth continuity, polarity, resistance to earth and short circuit, using a suitable test meter.
3. After wiring the boiler, all grommets in the bottom panel MUST be in place to ensure that the boiler case sealing is maintained.

### B. gas Installation

1. The whole of the gas installation, including the meter, should be inspected and tested for tightness and purged in accordance with the recommendations of BS. 6891. In IE refer to IS.813:2002.
2. Purge air from the gas installation by the approved methods only.

**Warning.** Whilst effecting the required gas tightness test and purging air from the gas installation, open all windows and doors, extinguish naked lights and *do not smoke*.

### gENERAL

**please note:** The combustion for this appliance has been checked, adjusted and preset at the factory for operation on the gas type defined on the appliance data plate. No measurement of the combustion is necessary. **DO NOT** adjust the air/gas ratio valve.

Having checked:

- That the boiler has been installed in accordance with these instructions.
- The integrity of the flue system and the flue seals, as described in the Flue Installation section.

Proceed to put the boiler into operation as follows:

### ChECK ThE OpERaTIONAL (WORKING) gas INLET pREssURE

Set up the boiler to operate at maximum rate.

With the boiler operating in the maximum rate condition check that the operational (working) gas pressure at the inlet gas pressure test point complies with the requirements - refer to "Gas Supply" on page 8.

Ensure that this inlet pressure can be obtained with all other gas appliances in the property working.

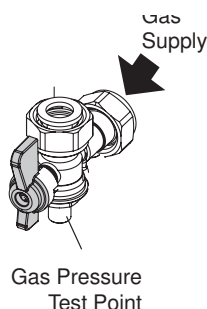

**As part of the commissioning process, the combustion of this appliance must be checked and the Benchmark Checklist completed. A flow chart to assist is provided on page 61.**

**aTTENTION !**  
**IT IS a CONDITION OF ThE MaNUF aCTURERs W aRRaNTy ThaT ThE**  
**BENCHMaRK COMMIssIONING ChECKLIst IS FULL y COMpLETED**  
**AND LEFT WITH ThE apPLIaNCe**

## 41 INITIAL LIGHTING

### Legend

- a. CH temperature control
- B. Mode Control Knob
- C. Boiler Status
- D. Burner 'on' indicator
- E. Gas Inlet Pressure Test Point
- F. Gas Service Cock

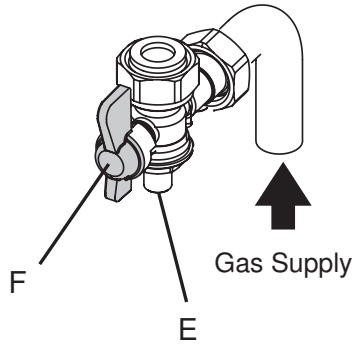
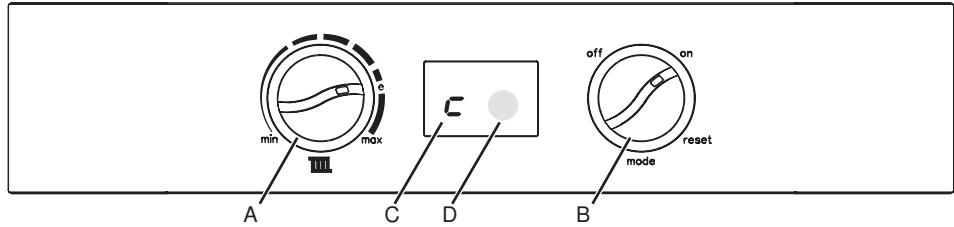

205862-10076

1. Check that the system has been filled and that the boiler is not airlocked.

### Note.

*It is important the burner is not operated before the system is fully vented of air. If it is necessary to operate the system pump to assist venting of the air this must be done with the gas service cock turned off.*

2. Refit the boiler front panel. Refer to Frame 46.
3. Check that the electrical supply is OFF.
4. Check that the boiler mode control knob (B) is off.
5. Check that the gas service cock (F) is OPEN.
6. Slacken the screw in the inlet pressure test point (E) and connect a gas pressure gauge via a flexible tube.
7. Switch the electricity supply ON and check all external controls are calling for heat.

### CENTRAL HEATING

8. Set the CH temp control (A) to max and turn the mode control knob (B) to ON. The boiler control should now go through its ignition sequence until the burner is established.
9. If the boiler does not light code  $L-c$  will be displayed. After 5 attempts the boiler will lock out and display fault code  $L-c$  constantly. Reset the boiler (Refer to Frame 43). The boiler will repeat its ignition sequence. If reset occurs 5 times within 15 minutes then  $L-5$  will be shown. If power is removed this will be reset.

When the burner is established the BLUE 'Burner On' neon (D) will be illuminated, the LED display (C) will show status  $c$ .

10. Ensure that with the boiler operating the dynamic gas pressure is able to obtain maximum output. Refer to Table 2.

### IMPORTANT

**The gas input to the burner is regulated by the gas valve according to the air flow produced by the fan. It is NOT user-adjustable. Any interference to sealed settings on the**

**valve will adversely affect operation and render our warranty void.**

For additional gas supply information refer to "Gas Supply" on page 8.

### The Display

The user control has one neon and one display to inform the user about the status. The display will show the status of the boiler. The neon will show the status of the flame. If no flame is detected the neon is off. When the flame is detected the neon will be lit permanently.

Below is a list with display function in normal operation.

- $\emptyset$  Standby, no demand for heat present.
- $c$  Boiler is active for heating.
- $F$  Boiler is active for boiler frost protection.
- $L$  Boiler is in lockout for a specific error. Display will be blinking, alternating with a number or letter to show which error is detected.
- $F$  Boiler has a fault for a specific error. Display will be blinking, alternating with a number or letter to show which error is detected.

**Note:** Boiler frost protection - boiler fires if temperature is below 5 degrees C.

*Note. The boiler incorporates a fan overrun cycle which MUST NOT be prematurely interrupted by isolation of the mains electricity supply.*

## 42 gENERaL ChECKS

Make the following checks for correct operation:

### CENTRaL hEaTING (Ch) MODE

1. Ensure that the CH external controls are calling for heat.

The display should read: 

2. Check the boiler gas rate when the boiler is at full output.

Check at the gas meter, with no other appliance in use.

Refer to Table 2 for gas rate.

3. Set the central heating external controls to OFF. The burner should go off and the pump continue to run for two minutes

The display should read: 

4. Check the correct operation of all system controls. Operate each control separately and check that the main burner responds.

### WaTER CIRCULaTION sysTEM

1. With the system COLD, check that the initial pressure is correct to the system design requirements.

For pre-pressurised systems, this should be 1.0 bar.

2. With the system HOT, examine all water connections for soundness. The system pressure will increase with temperature rise but should not exceed 2.5 bar.

3. With the system still hot, turn off the gas, water and electricity supplies to the boiler and drain down to complete the flushing process.

**Note:** A flushing solution should be used during the flushing procedure. Flushing solutions: Fernox Superfloc, Sentinel X300 (new systems) or X400 (existing systems). Refer to Frame 5.

4. Refill and vent the system, add inhibitor (see Frame 5), clear all air locks and again check for water soundness.
5. Reset the system initial pressure to the design requirement.
6. Balance the system. Refer to Frame 4.
7. Check the condensate drain for leaks and check that it is discharging correctly.
8. Finally, set the controls to the User's requirements.

### WaTER TEMpERaTUREs

Temperatures can be selected using the CH temp ctrl (A)

Knob Setting	CH Flow Temp °C (°F)
Max	80 (176)
Min	30 (86)

## 43 REsET pROCEDURE

To reset boiler, turn the mode control knob (B) to reset position and immediately turn knob back to required setting. The boiler will repeat the ignition sequence if a heat demand is present.

### Legend

- a. CH temperature control
- B. Mode Control Knob
- C. Boiler Status
- D. Burner 'on' indicator

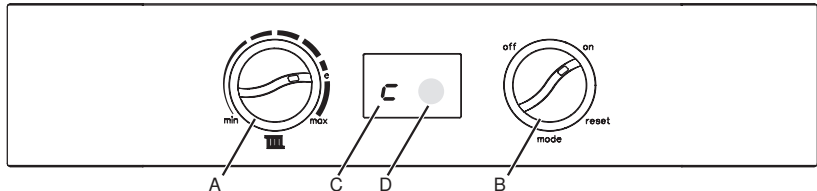

## 44 haNDING OvER

after completing the installation and commissioning of the system the installer should hand over to householder by the following actions:

1. Hand the User Instructions to the householder and explain his/her responsibilities under the relevant national regulations.
2. Explain and demonstrate the lighting and shutting down procedures.
3. The operation of the boiler and the use and adjustment of all system controls should be fully explained to the householder, to ensure the greatest possible fuel economy consistent with the household requirements of both heating and hot water consumption.  
Advise the User of the precautions necessary to prevent damage to the system and to the building, in the event of the system remaining inoperative during frosty conditions.
4. Explain the function and the use of the boiler heating controls.
5. Explain the function of the boiler fault mode.  
Emphasise that if a fault is indicated refer to "Fault Codes" in the User Guide.
6. Explain and demonstrate the function of time and temperature controls, radiator valves etc., for the economic use of the system.
7. If a timer is fitted draw attention to the timer Users Instructions and hand them to the householder.
8. Explain Boiler reset procedure.
9. After installation and commissioning please complete the Benchmark Commissioning Checklist before handover to the customer. For IE, its is necessary to complete a "Declaration of Conformity" to indicate compliance to I.S. 813:2002.

### IMpORTaNT

10. A comprehensive service should be carried out ANNUALLY.  
Stress the importance of regular servicing by a Gas Safe Registered Engineer. In IE servicing work must be carried out by a Registered Gas Installer (RGI).
11. Inform the householder of the guarantee/registration found within the envelope pack and the requirement to register it to receive the full benefit of the warranty.

## 45 sERVICINg sChEDULE

For the very latest copy of literature for specification & maintenance practices, visit our website [www.idealboilers.com](http://www.idealboilers.com), where you will be able to download the relevant information. N.B. Technical Bulletins are also available on [www.idealboilers.com](http://www.idealboilers.com).

**Warning.** always turn OFF the gas supply at the gas service cock, and switch OFF and disconnect the electricity supply to the appliance before servicing.

**Combustion testing must be carried out by a competent person using a combustion analyser conforming to Bs7927.**

To ensure the continued safe and efficient operation of the appliance it is recommended that it is checked at regular intervals and serviced as necessary. The frequency of servicing will depend upon the installation condition and usage but should be carried out at least annually.

It is the law that any service work must be carried out by a Gas Safe Registered Engineer. In IE service work must be carried out by a Registered Gas Installer (RGII).

### INspECTION

1. Light the boiler and carry out a pre-service check, noting any operational faults.
2. Check the flue terminal (and terminal guard if fitted) is undamaged and clear of any obstruction.
3. Check all water and gas joints for signs of leakage. Remake any suspect joints ensuring a gas tightness check is carried out if applicable and the water system is correctly refilled, vented and on sealed systems only re-pressurised.

### CLEaNING pROCEDURE

**Note.** In order to carry out either servicing or replacement of components the boiler front panel must be removed. Refer to Frame 46.

1. Clean the main burner. Refer to frame 48.
2. Clean the heat exchanger & condensate trap/siphon. Refer to Frames 49 & 50.
3. Check the main injector for blockage or damage. Refer to Frame 47.
4. Check that the flue terminal is unobstructed and that the flue system is sealed correctly.

The cleaning procedures are covered more fully in Frames 51-55 and MUST be carried out in sequence.

### IMpORTaNT.

6. After completing the servicing or exchange of components always test for gas tightness.
7. When work is complete the front panel MUST be correctly refitted, ensuring that a good seal is made.

**do noT opera Te the boiler if the front panel is not fitted.**

8. If, for any reason, the condensate trap/siphon has been removed ensure the trap is refilled with water before reassembling.
9. Check the gas consumption.
10. Check combustion by connecting the flue gas analyser to the flue gas sampling point as shown in the diagram and measure CO & CO<sub>2</sub>.

If the CO/CO<sub>2</sub> ratio is greater than 0.004 AND the integrity of the complete flue system and combustion circuit seals have been verified and the inlet gas pressure (and gas rate) have been verified, then contact Ideal.

11. Complete the service section in the Benchmark Commissioning Checklist.

### gENERaL

**please note:** During routine servicing, and after any maintenance or change of part of the combustion circuit, the following must be checked:

- The integrity of the flue system and the flue seals,
- The integrity of the boiler combustion circuit and the relevant seals
- The operational (working) gas inlet pressure at maximum rate.
- The gas rate
- The combustion performance.

### COMPETENCE TO CaRRy OUT The ChECK OF COMBUStION pERFORMaNCE

**please note:** BS 6798:2009 Specification for installation and maintenance of gas-fired boilers of rated input not exceeding 70kW net advises that:

- The person carrying out a combustion measurement should have been assessed as competent in the use of a flue gas analyser and the interpretation of the results.
- The flue gas analyser used should be one meeting the requirements of BS7927 or BS-EN50379-3 and be calibrated in accordance with the analyser manufacturers requirements, and
- Competence can be demonstrated by satisfactory completion of the CPA1 ACS assessment, which covers the use of electronic portable combustion gas analysers in accordance with BS7967, Parts 1 to 4.

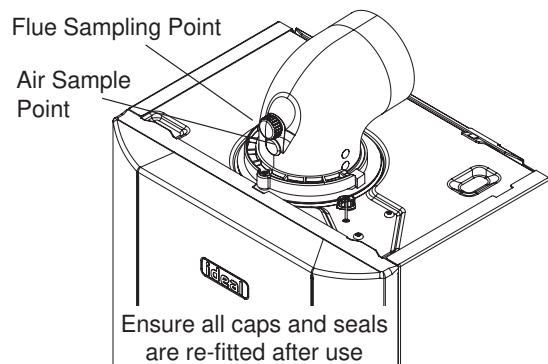

## 46 BOILER FRONT PANEL REMOVAL / REPLACEMENT

### REMOVAL

1. Loosen the two screws retaining the front panel.
2. Pull the two spring clips down to disengage and pull panel forward and upward and remove.

### REPLACEMENT

3. Hook the panel onto the top retaining clips.
4. Push the panel until the 2 bottom spring clips engage ensuring the 4 control knobs line up with the holes in the front panel.
5. Re-tighten the two retaining screws.

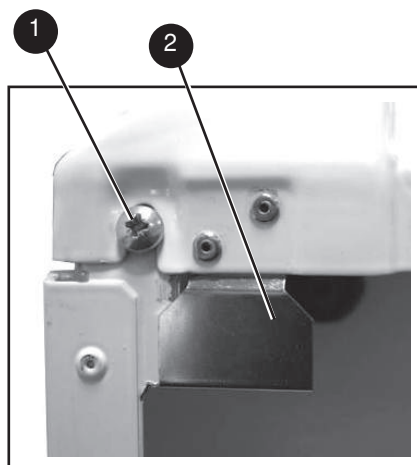

view from bottom of boiler

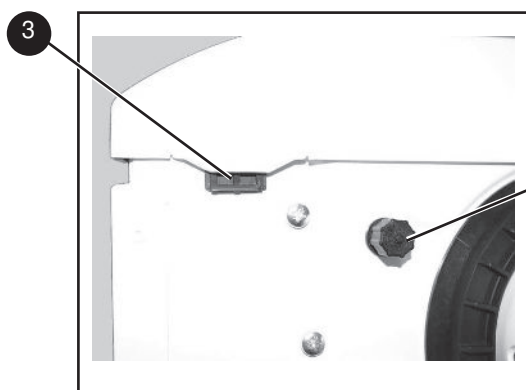

view from top of boiler

## 47 FaN aND VENTURI assEMBL y REMOVaL aND CLEaNING

1. Disconnect the electrical leads from the fan.
2. Undo the gas pipe union connection to the injector housing.
3. Remove the extended nut on the fan mounting bracket.
4. Lift off fan and venturi assembly.
5. Inspect the injector for blockage or damage.
6. Inspect fan outlet sealing gasket and replace if necessary.

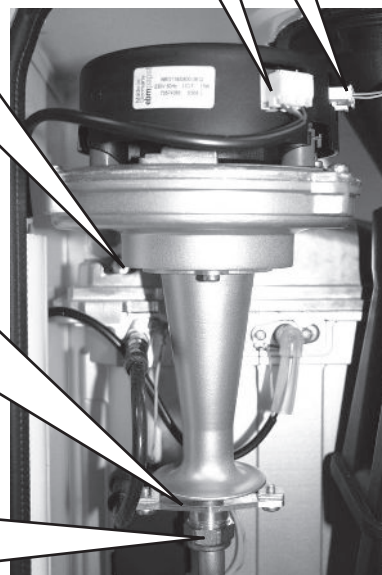
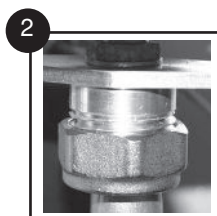
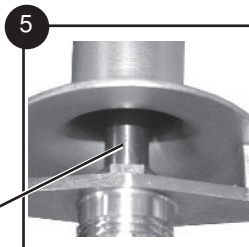
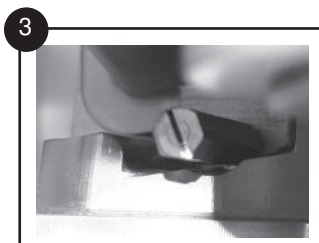

### 48 BURNER REMOVaL aND CLEaNINg

1. Ensure the sump is fully drained
2. Undo the two screws and remove the sump cover retaining the lower flue manifold.
3. Lift the manifold to clear the bottom sealing gasket and remove manifold.
4. Remove the 2 burner front fixing screws and loosen the 2 rear extended nuts by at least ten turns.
5. Lift off the burner from the combustion chamber. To facilitate the removal angle the burner as shown.

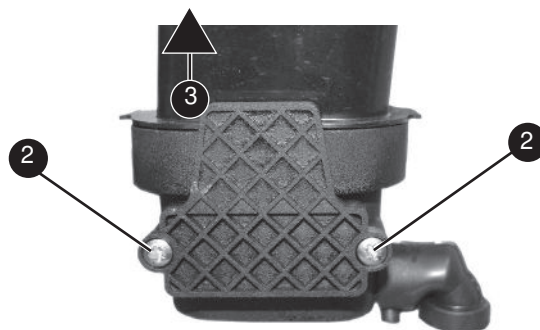

**IMpORTaNT**

The burner head is a ceramic plaque construction. Care must be taken to ensure that **the burner is not placed down upon its face** as this may cause damage to the ceramic.

6. Brush off any deposits that may be on the ceramic with a SOFT brush.
7. Inspect the sealing gasket around the burner for any signs of damage. Replace as necessary.

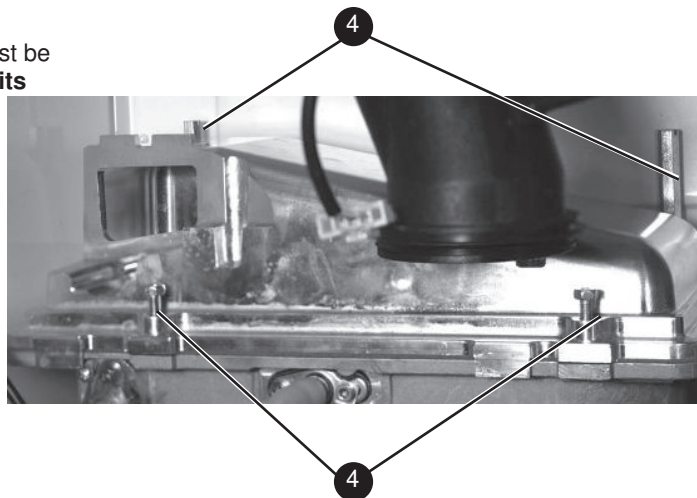

### 49 CLEANING THE CONDENSATE TRAP/SIPHON

1. Pull off the rubber pipe noting the position and flush out any deposits with clean water.
2. Replace the cleaning plug and refill the siphon with water.
3. Replace the rubber pipe connector with the twin wall seal fitted to the condensate siphon.

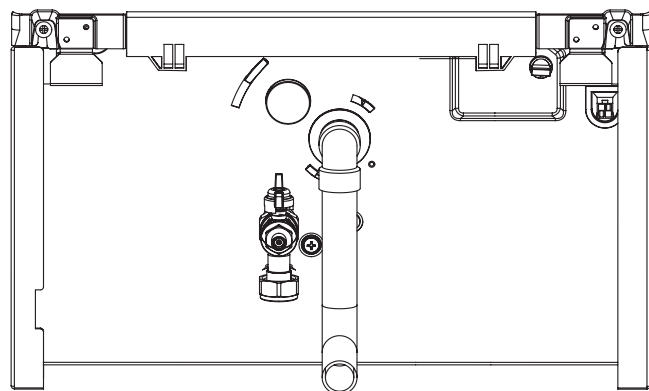
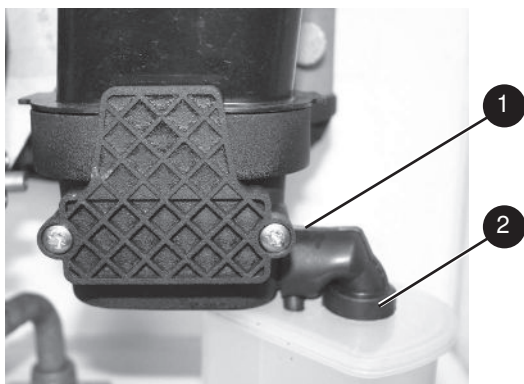

## 50 CLEANING THE HEAT EXCHANGER

**note:** Ensure the condensate trap/siphon is fully drained before cleaning. Refer to Frame 49.

1. Remove ignition and flame detection electrodes. Refer to Frames 57 & 58.
2. It is advisable to replace the sump cover prior to the water flush process.
3. Thoroughly flush the heat exchanger by pouring water into the top of the combustion chamber ensuring the full top area is covered.
4. Remove the sump cover and clean loose deposits from the sump.
5. Inspect the ignition and detection electrodes. Ensure that they are clean and in good condition - replace if necessary.
6. Re-fit the ignition and flame detection electrodes, ensuring that both earth tabs are fitted to ignition electrode.
7. Check that the ignition and detection gaps are correct. Refer to Frames 57 & 58.

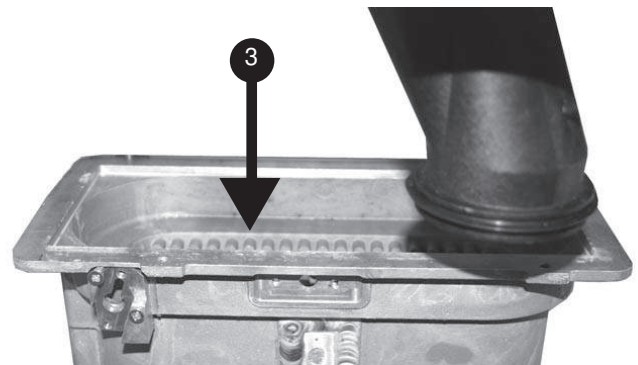
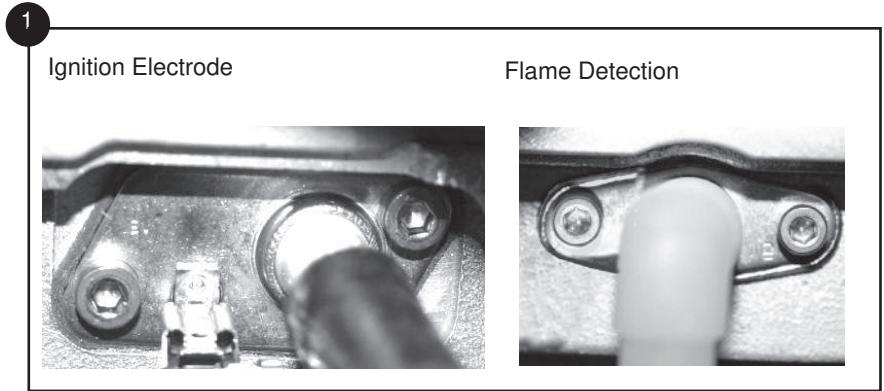

## 51 REASSEMBLY

**Reassemble the boiler in the following order:**

1. Ensure that the condensate trap/siphon is full of water.
  2. Refit the burner ensuring the sealing gasket is correctly positioned and free from damage (tighten the 4 fixing screws in the sequence shown below - A,B,C,D).
  3. Refit the fan / venturi assembly ensuring the retaining tabs are correctly positioned and the sealing gasket is correctly positioned and free from damage.
  4. Reconnect the fan electrical leads.
  5. Remove the sump cover and refit the lower flue manifold as shown.
  6. Refit the sump cover.
  7. Refit the boiler front panel.
- IMPORTANT.** Ensure that the boiler front panel is correctly fitted and that a good seal is made.
8. Swing the control box back into its working position and secure.
  9. Turn on the gas supply at the gas service cock.
  10. Reconnect the electrical supply.
  11. Check operation of the boiler. Refer to Frames 41 & 42.

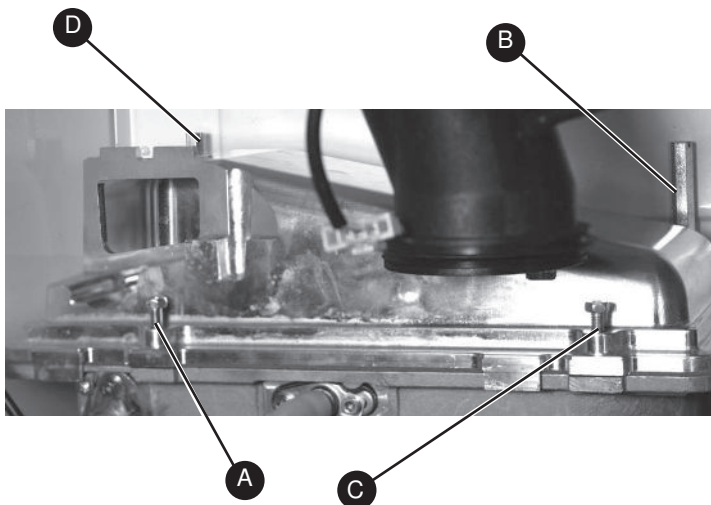

## 52 REpLaCEMENT OF COMpONENTs

### gENERaL

#### When replacing aNy component

1. Isolate the electricity supply.
2. Turn off the gas supply.
3. Remove the boiler front panel. Refer to Frame 46.
4. Release the retaining clip and swing the control box down into the servicing position.

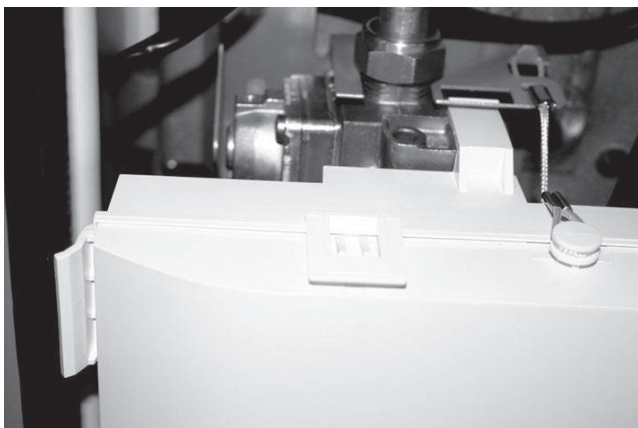

After replacing ANy component check operation of the boiler, including gas soundness, gas rate and combustion test.

### IMpORTaNT.

When work is complete, the front panel must be correctly refitted - ensuring that a good seal is made.

### Notes.

1. In order to assist fault finding, the control panel has an LED diagnostic display. The key to boiler fault conditions is shown in Frame 67.
2. In order to replace components in Frames 53-65 it is necessary to drain the boiler.

**ThE BOILER MUSt NOT BE OpERa TED WITHOut ThE FRONt paNEL FITTED**

## 53 FaN REpLaCEMENT

1. Refer to Frame 52.
2. Disconnect the electrical leads from the fan.
3. Undo the gas pipe union connection to the injector housing.
4. Remove the extended nut retaining the fan mounting bracket.
5. Lift and remove the fan and venturi assembly.
6. Remove the screw and twist venturi anti-clockwise to remove venturi assembly, *noting the orientation of the venturi in relation to the fan body.*
7. Transfer the venturi assembly to the new fan, replacing the 'o' ring if evidence of damage or deterioration is visible.
8. Fit the new fan / venturi assembly ensuring the retaining tabs are correctly positioned and the fan outlet sealing gasket is correctly positioned and free from damage. Refit the extended nut.
9. Reassemble the boiler in reverse order, taking care not to overtighten the screw on the fan mounting bracket.
10. Check the operation of the boiler. Refer to Frames 41 & 42.

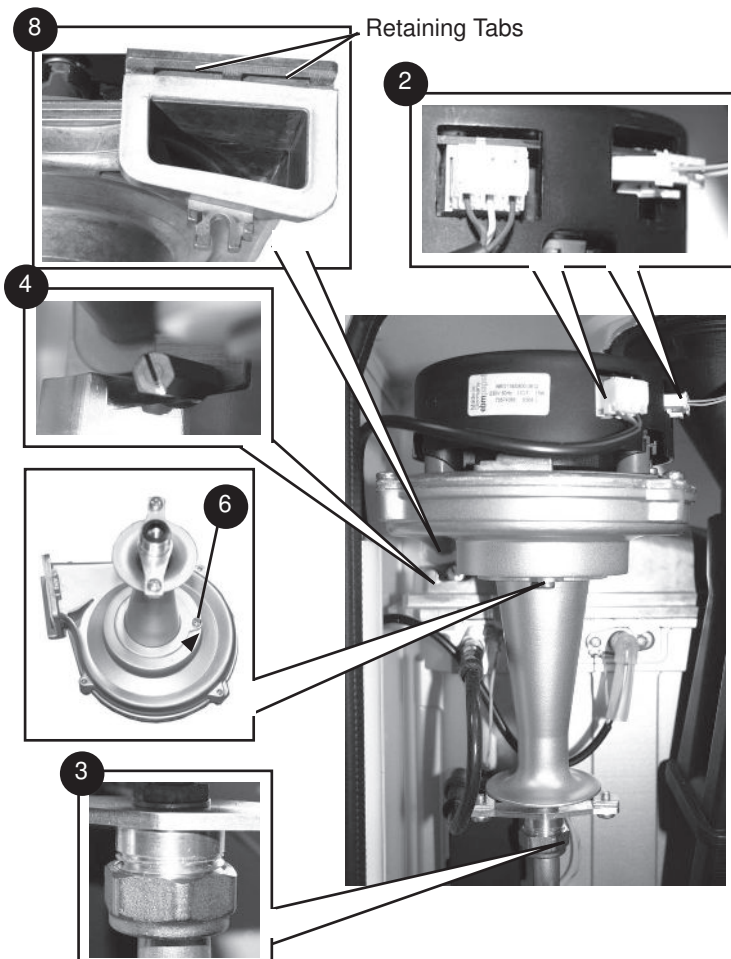

## 54 BURNER INJECTOR REpLaCEMENT

1. Refer to Frame 52.
2. Disconnect the electrical leads from the fan.
3. Undo the gas pipe union connection to the injector housing.
4. Loosen the screw retaining the fan mounting bracket.
5. Lift and remove the fan and venturi assembly.
6. Remove the 2 injector housing screws.
7. Withdraw the injector housing.
8. Fit the new injector housing complete with injector.
9. Reassemble in reverse order, ensuring that the new gas seal supplied is located correctly in the injector housing.
10. Check operation of the boiler. Refer to Frames 41 & 42.

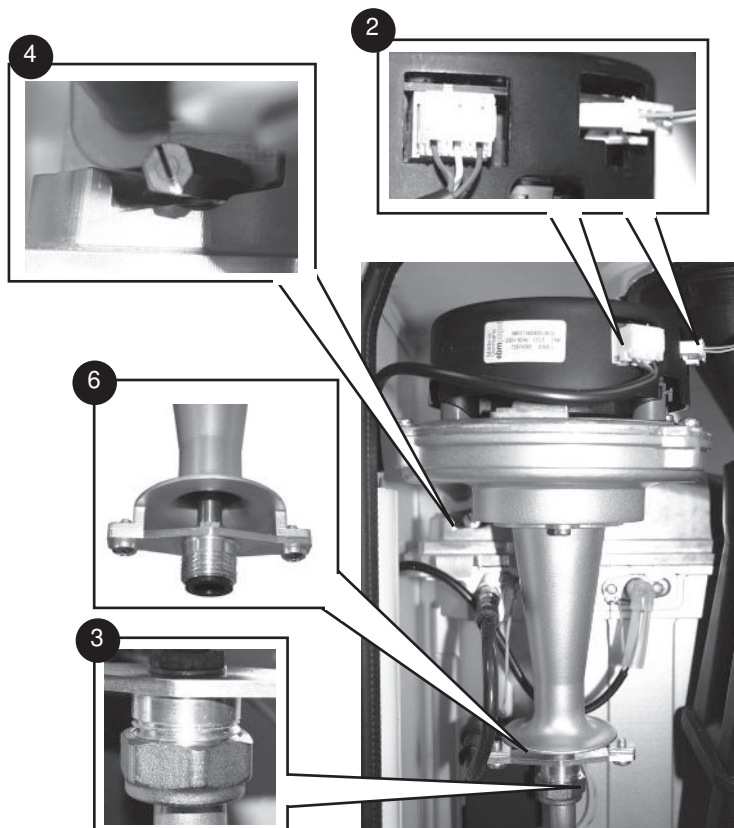

## 55 BURNER REpLaCEMENT

1. See Frame 48.
2. Refer to Frame 52.
3. Undo the two screws and remove the sump cover.
4. Lift the manifold to clear the bottom sealing gasket and remove manifold.
5. Remove the 2 front fixing screws and loosen the 2 rear extended nuts.
6. Lift off the burner from the combustion chamber. To facilitate the removal angle the burner as shown.
7. Fit the new burner, replacing any damaged or deteriorating sealing gasket.
8. Reassemble in reverse order. Refer to Frame 51.
9. Check the operation of the boiler. Refer to Frames 41 & 42.

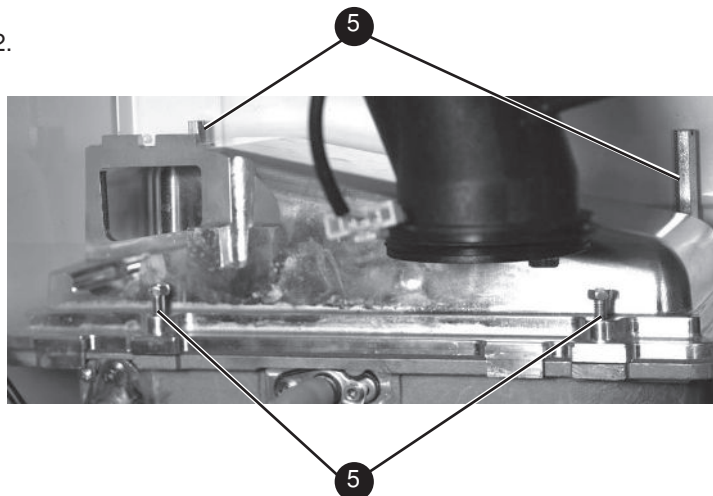
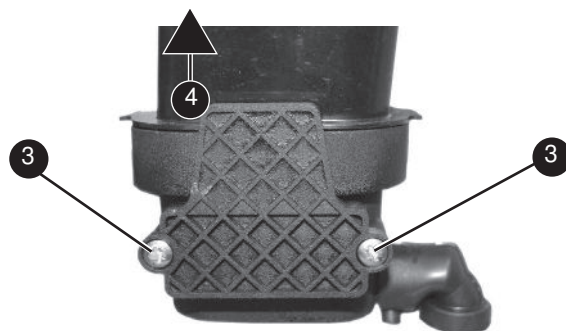

## 56 CONTROL & RETURN THERMISTOR RENEWAL

1. Refer to Frame 52.
2. Disconnect the electrical leads from the thermistors.
3. Unclip the flow thermistor from the flow pipe and withdraw it from the boiler.
4. Unclip the return thermistor from the return pipe and withdraw it from the boiler.
5. Reconnect the electrical lead to the new thermistors and reassemble in reverse order, ensuring that the thermistor is securely fitted to the pipe on the thermistor locator tab as shown.
6. Check the operation of the boiler. Refer to Frames 41 & 42.

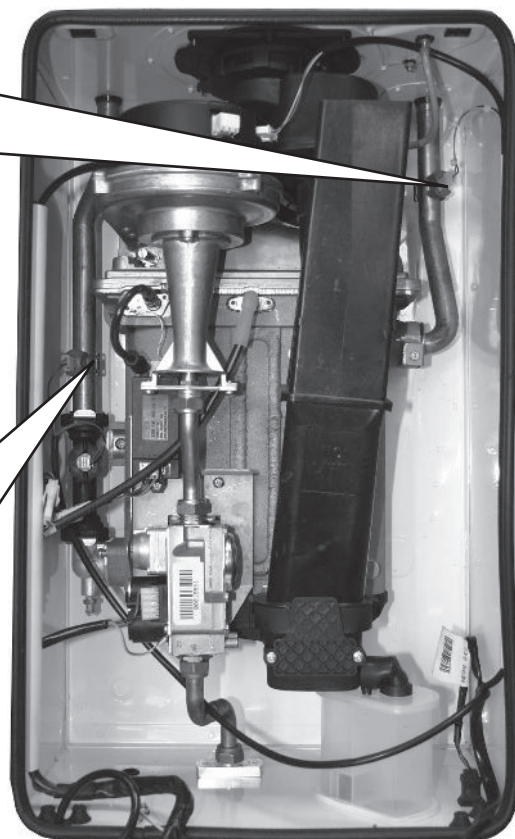
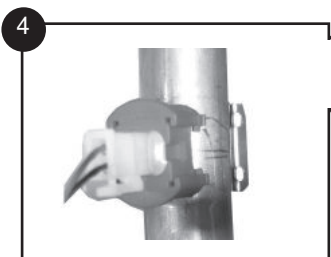
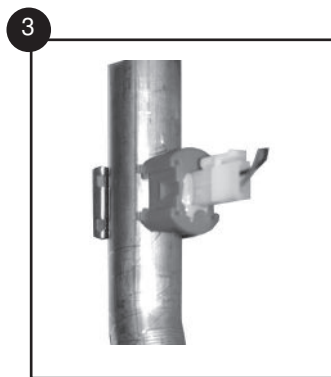
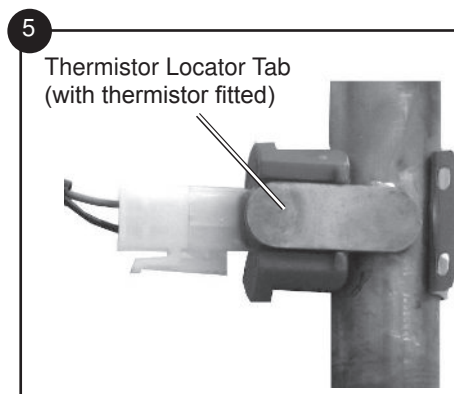

## 57 IGNITION ELECTRODE REPLACEMENT

1. Refer to Frame 52.
2. Remove the burner. Refer to Frame 55.
3. Unplug the ignition lead from the electrode.
4. Remove the earth lead from the ignition electrode.
5. Remove the 2 screws holding the ignition electrode to the combustion chamber.
6. Remove the electrode.
7. Fit the new ignition electrode, using the new gasket supplied. Check dimensions as shown.
8. Reassemble in reverse order.
9. Check the operation of the boiler. Refer to Frames 41 & 42.

Ignition Electrode

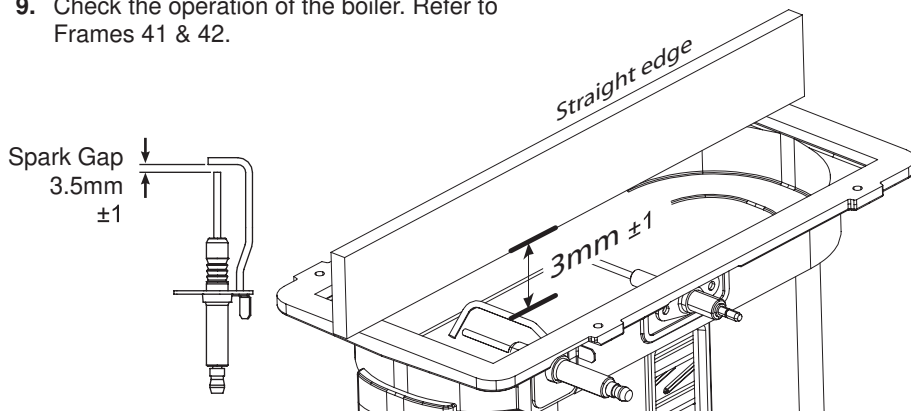
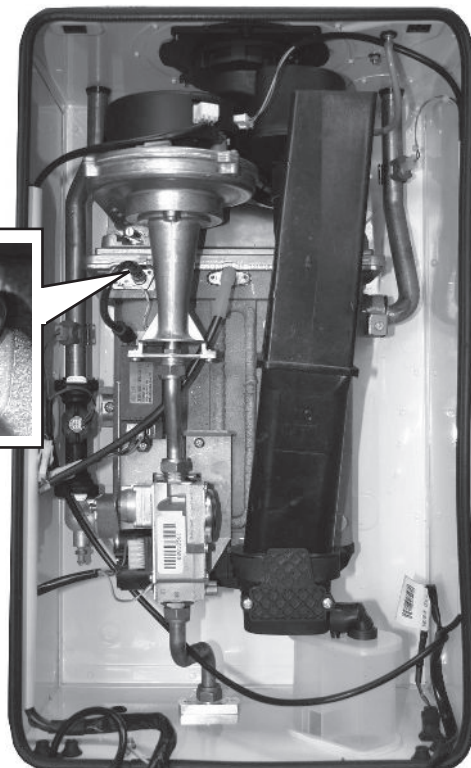
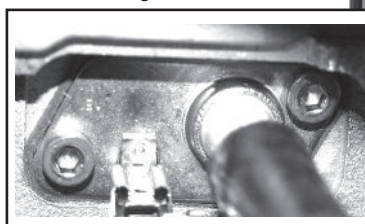

## 58 FLAME DETECTION ELECTRODE REpLaCEMENT

1. Refer to Frame 52.
2. Remove the burner. Refer to Frame 55.
3. Unplug the flame detection lead from the electrode.
4. Remove the 2 screws retaining the detection electrode.
5. Remove the electrode.
6. Fit the new flame detection electrode (check dimension as shown below), using the new gasket supplied.
7. Reassemble in reverse order.
8. Check the operation of the boiler. Refer to Frames 41 & 42.

Flame Detection Electrode

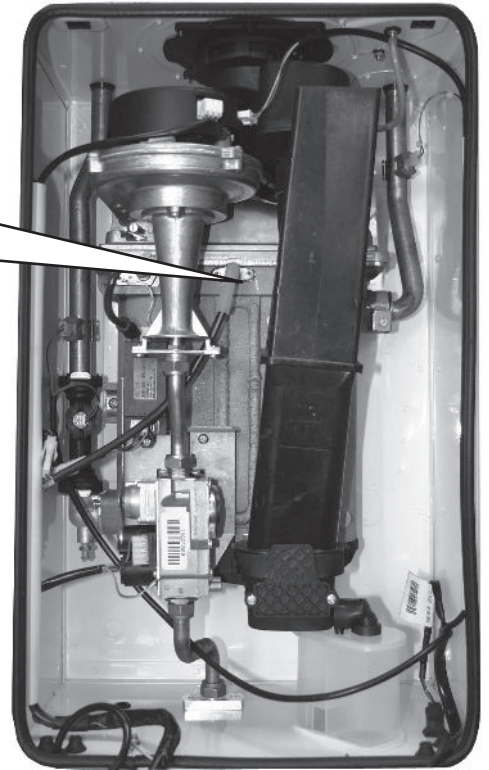
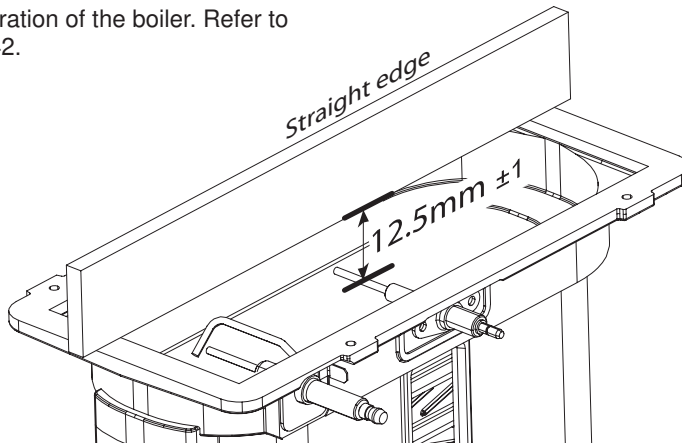
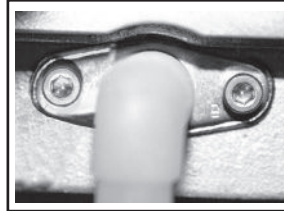

## 59 spaRK gENERa TOR REpLaCEMENT

1. Refer to Frame 52.
2. Disconnect the leads from the spark generator.
3. Remove the M5 screws securing the spark generator to the boiler chassis.
4. Fit the new spark generator and reassemble in reverse order ensuring the two earth leads are correctly replaced.
5. Check operation of the boiler. Refer to Frames 41 & 42.

Spark Generator

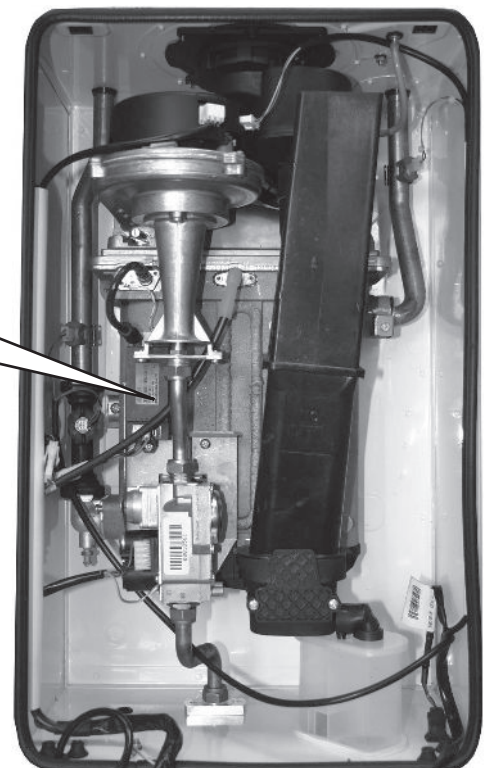
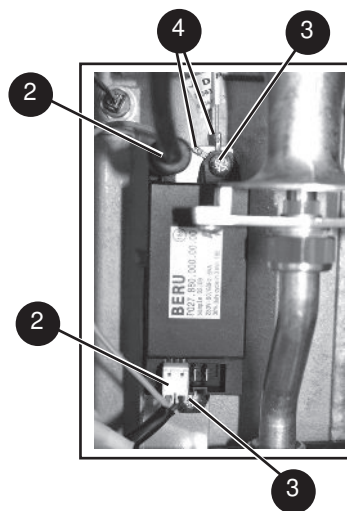

## 60 gas CONTROL Valve REpLaCEMENT

1. Refer to Frame 52.
2. Unplug the electrical lead connection from the gas control valve and disconnect the earth wire.
3. Undo the union nut on the outlet of the gas control valve.
4. Undo the gas inlet pipe union at the inlet to the gas control valve.
5. Loosen the back nut retaining the valve to the bracket and withdraw the valve forwards.
6. Fit the new gas control valve ensuring the two sealing washers are in place and reconnect gas and electrical connections.
7. Check operation of the boiler. Refer to Frames 41 & 42.

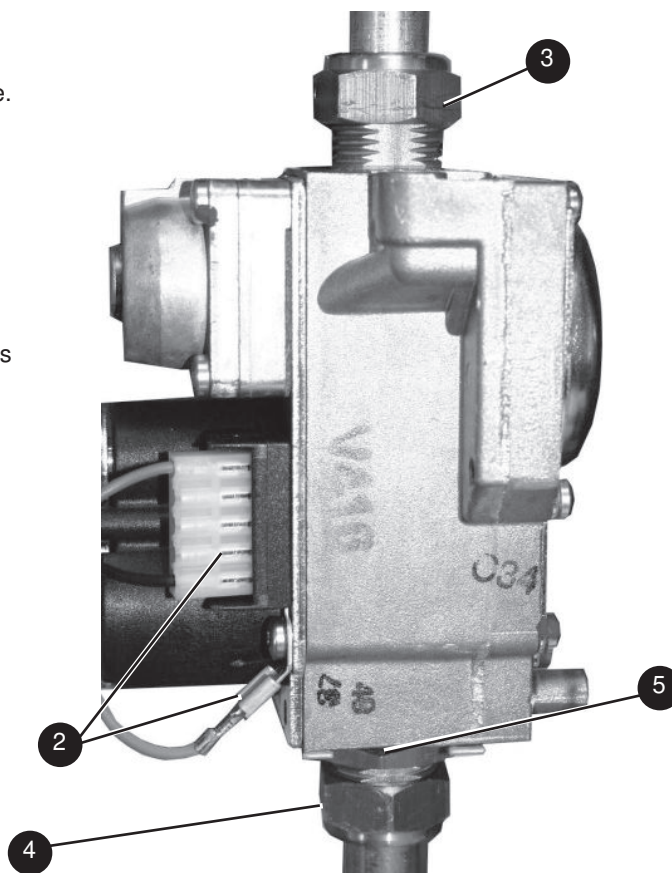

## 61 CONDENSATE TRAP/SIPHON REPLACEMENT

1. Refer to Frame 52.

**Note:** Ensure condensate trap is fully drained before removal.

2. Pull off the rubber pipe at the sump drain.
3. Disconnect the condensate drain pipe.
4. Turn the siphon clockwise to disengage and lift to remove.
5. Reassemble in reverse order.
6. When reassembling ensure the trap is full of water.
7. Check operation of the boiler. Refer to Frames 41 & 42.

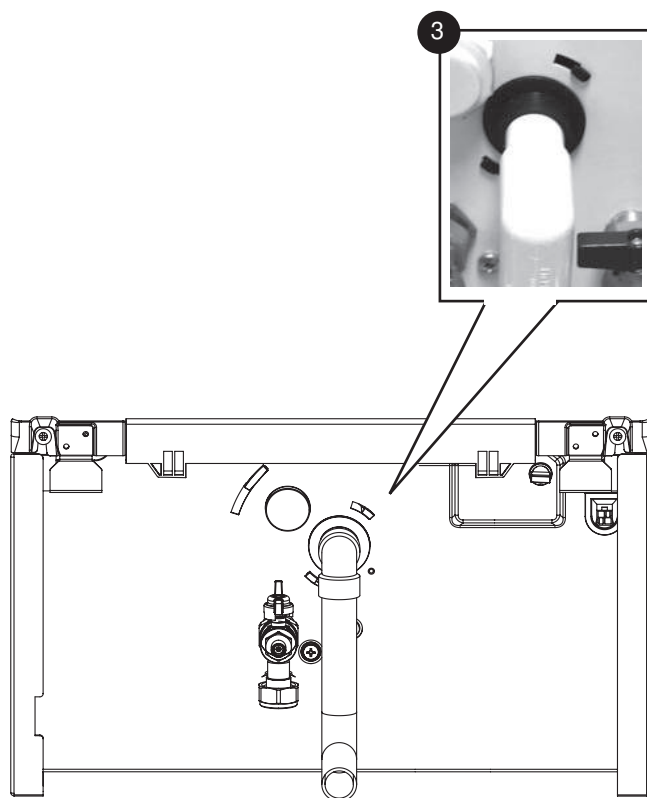
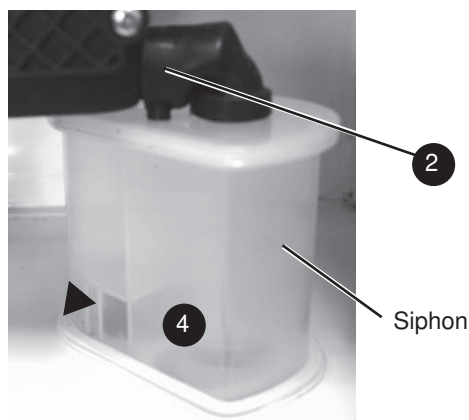

## 62 MAIN pCB REpLaCEMENT

Note that production boiler PCBs are factory pre-set to operate for boiler range and output, but when ordering Primary PCB as a spare, an additional Boiler Chip Card (BCC) MUST also be purchased for your specific boiler range and output.

**Note.** Fit the earth strap provided with the PCB to your wrist and secure to a suitable earth on the boiler chassis.

1. Refer to Frame 52.
2. Note the control knob positions.
3. Remove the 2 screws retaining the control box cover.
4. Carefully lift the 4 retaining clips and remove control box cover.
5. Unplug all lead connections to the PCB including the ribbon cable (to facilitate ribbon cable removal, ease side clips apart and pull upwards), also where applicable, push the small plastic clip with an electrical screwdriver to facilitate plug removal.
6. Spring out the two side retaining clips and pull the PCB upwards to clear the 4 corner retaining posts.
7. Take the new Primary PCB and attach the appropriate Boiler Chip Card (BCC) to it (this should correspond to the output of the boiler: 12kW, 15kW, 18kW, 24kW or 30kW).  
**Note.** Ensure the correct orientation of BCC by placing "TOP" side up as shown.
8. Re-connect all plug connections.
9. Reassemble in reverse order.
10.
  - a. Turn power on
  - b. Displays "8" blue light on/off, "first digit input", "second digit input", "1st letter appliance type", i.e. "2", "4", "h"
  - c. Move knob to required setting (standby, summer, winter)  
**Note.** If no BCC fitted on non programmed board items a & b will be displayed then "Boiler Type Card Fault - Contact Installer" The correct BCC for this appliance will need to be fitted.
11. Check operation of the boiler. Refer to Frames 41 & 42.

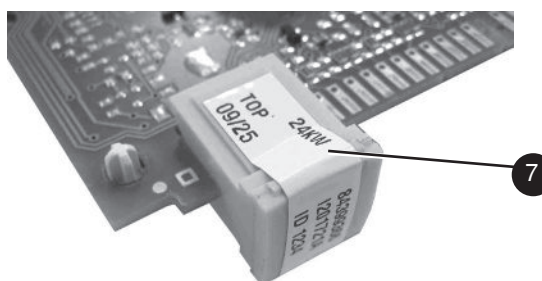
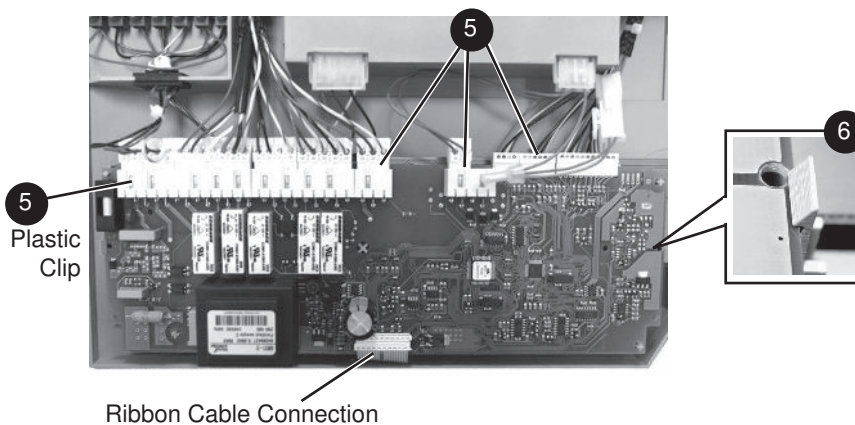
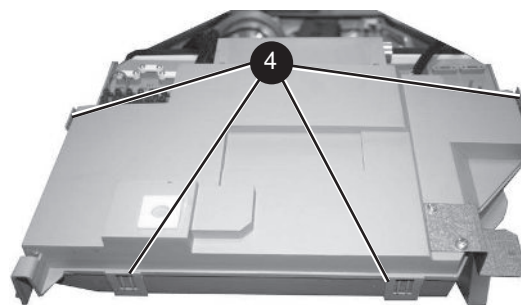
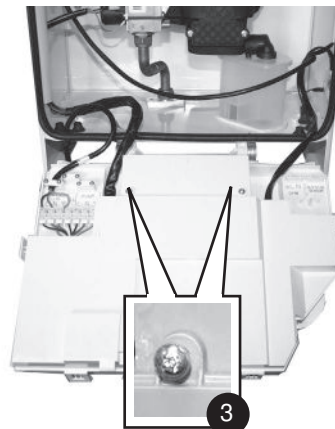

### 63 UsER CONTROL pCB REpLaCEMENT

**Note.** Fit the earth strap provided with the PCB to your wrist and a suitable earth on the boiler chassis.

1. Refer to Frame 52.
2. Remove the main PCB, refer to Frame 66.
3. Unclip the PCB and lift to clear the mounting posts.
4. Fit the new PCB ensuring the 2 potentiometer spindles line up with the control knobs which must be in a vertical position.
5. Reassemble in reverse order.
6. Check operation of the boiler. Refer to Frames 41 & 42.

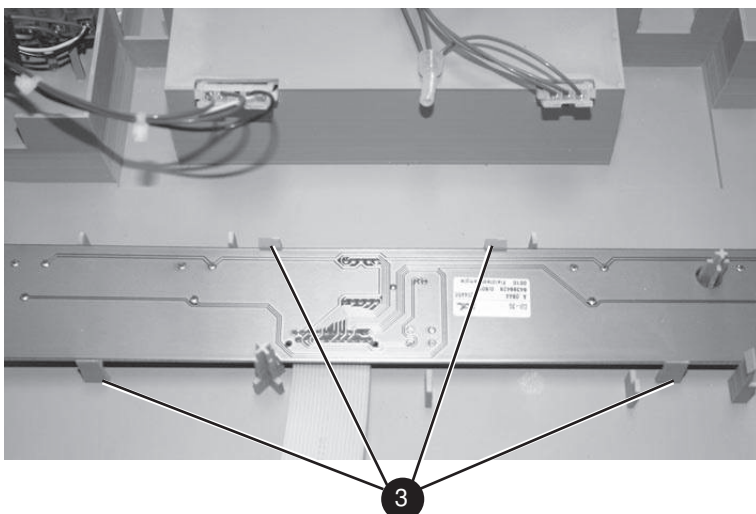

4

PCB

Control Knobs (to be in vertical position)

Potentiometer spindle

3G9954

### 64 WaTER FLOW sWITCh hEAd REpLaCEMENT

1. Refer to Frame 52.
2. Drain the Boiler.
3. Pull off the electrical connection.
4. Turn the retaining collar anti-clockwise and pull the head from the housing.
5. Fit the new water flow switch head, ensuring the electrical lead connections wires point to the right as shown.
6. Re-assemble in reverse order.
7. Re-fill the boiler.
8. Check the operation of the boiler. Refer to Frames 41 & 42.

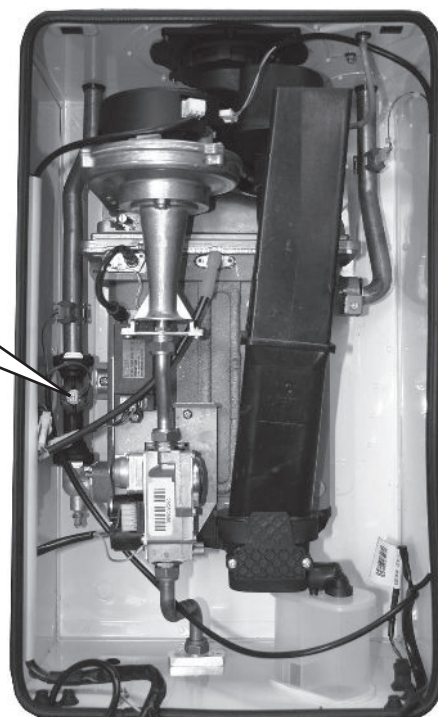
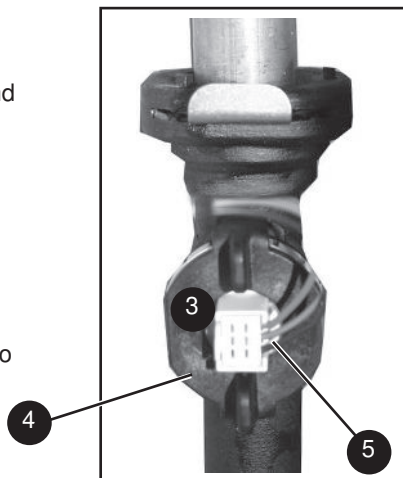

## 65 hEa T ENgINE RENEWaL - Refer also to Frame 10 - 'Boiler Exploded View'

**Note.** To remove the flow and return pipe connections from the heat exchanger, it may be necessary to cut the pipes above the boiler.

### IMpORTaNT

Before starting the removal procedure, protect the gas and electrical controls with a waterproof sheet or plastic bag.

1. Refer to Frame 52.
2. Drain the boiler from the drain point provided.
3. Remove the fan / venturi assembly and place on one side. Refer to Frame 53.
4. Remove the burner and place on one side. Refer to Frame 55.
5. Remove the ignition and detection electrodes. Refer to Frames 57 and 58.
6. Remove the spark generator. Refer to Frame 59.
7. Remove the gas valve. Refer to Frame 60.
8. Remove the 2 M5 screws retaining the gas valve mounting bracket and transfer bracket to the new heat exchanger.
9. Pull the bottom clip, retaining the water flow switch housing, forward to remove.
10. Lift the housing/return pipe assembly upwards to disengage from the heat exchanger return pipe elbow.
11. Remove the screw retaining the flow pipe bracket and remove the bracket from its rear retention slot.
12. Pull the flow pipe to the right to disengage from the heat exchanger.
13. Remove the condensate rubber pipe. Refer to Frame 61.
14. Remove the LH heat exchanger fixing screw.
15. Pull the heat exchanger to the left to disengage the rear retention pegs and remove the heat exchanger.
16. Reassemble in reverse order, ensuring the heat exchanger is correctly positioned. Replace any new 'o' rings supplied with new heat exchanger and replacing gaskets or seals if any sign of damage is evident.

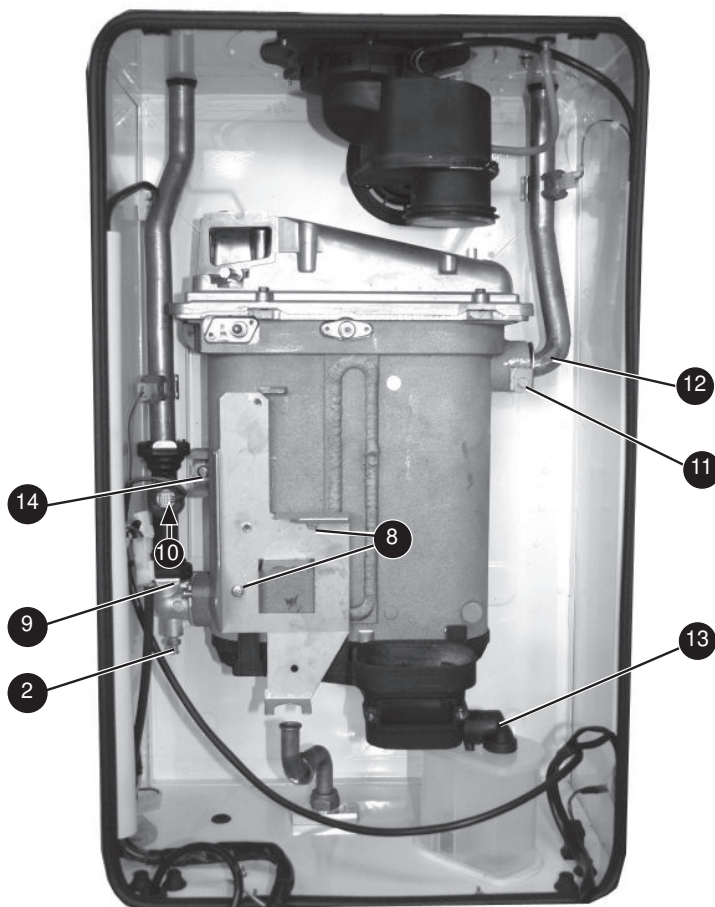

17. Ensure the trap/siphon is filled with water. Refer to Frame 61.
18. Refill the boiler.
19. Check operation of the boiler. Refer to Frames 41 & 42.

## 66 BOILER sEaLING paNEL sEaL REpLaCEMENT

1. Refer to Frame 52.
2. Remove the old seal from the casing and thoroughly clean the casing surfaces.
3. Fit the new seal, ensuring the bottom joint provides an air tight seal.
5. Reassemble in reverse order.
6. Check operation of the boiler. Refer to Frames 41 & 42.

**Note.** Ensure that the boiler front panel is correctly sealed, compressing the seal to make an airtight joint.

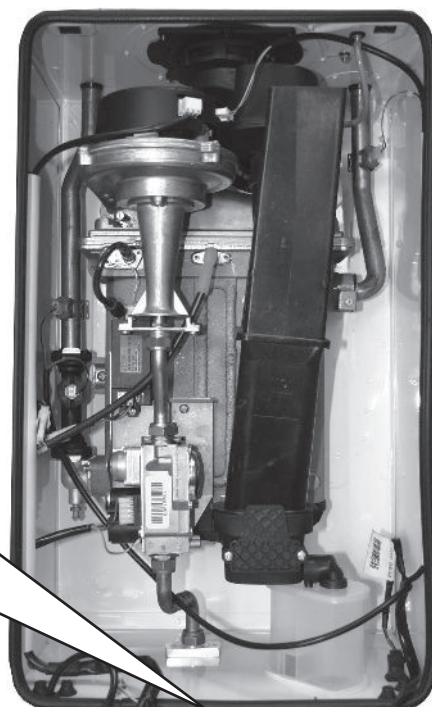
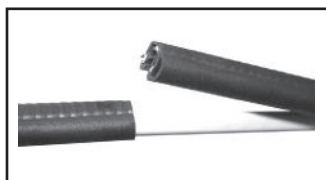











## spaRE paRTs

When replacing any part on this appliance use only spare parts that you can be assured conform to the safety and performance specification that we require. Do not use reconditioned or copy parts that have not been clearly authorised by Ideal. Failure to do so could affect safety or performance of this appliance.

Comprehensive spares parts information and details of approved Ideal Parts Distributors are available on [www.idealparts.com](http://www.idealparts.com)

**Our parts team are also available to help with your Ideal spare parts enquiries on 01482 498665.**

When calling, and to ensure we can provide you with the most accurate parts information, please ensure you have the following to hand;

- Boiler Model
- Appliance GC Number
- Boiler Serial Number

# Code Of Practice

For the installation, commissioning and servicing  
of domestic heating and hot water products

Benchmark places responsibilities on both manufacturers and installers.\* The purpose is to ensure that customers\*\* are provided with the correct equipment for their needs, that it is installed, commissioned and serviced in accordance with the manufacturer's instructions by competent persons and that it meets the requirements of the appropriate Building Regulations. Installers are required to carry out work in accordance with the following:

## Standards of Work

- Be competent and qualified to undertake the work required.
- Install, commission, service and use products in accordance with the manufacturer's instructions provided.
- Ensure that where there is responsibility for design work, the installation is correctly sized and fit for purpose.
- Meet the requirements of the appropriate Building Regulations. Where this involves notifiable work be a member of a Competent Persons Scheme or confirm that the customer has notified Local Authority Building Control (LABC), prior to work commencing.
- Complete all relevant sections of the Benchmark Checklist/Service Record when carrying out commissioning or servicing of a product or system.
- Ensure that the product or system is left in a safe condition and, whenever possible, in good working order.
- Highlight to the customer any remedial or improvement work identified during the course of commissioning or servicing work.
- Refer to the manufacturer's helpline where assistance is needed.
- Report product faults and concerns to the manufacturer in a timely manner.

## Customer Service

- Show the customer any identity card that is relevant to the work being carried out prior to commencement or on request.
- Give a full and clear explanation/demonstration of the product or system and its operation to the customer.
- Hand over the manufacturer's instructions, including the Benchmark Checklist, to the customer on completion of an installation.
- Obtain the customer's signature, on the Benchmark Checklist, to confirm satisfactory demonstration and receipt of manufacturer's instructions.
- Advise the customer that regular product servicing is needed, in line with manufacturers' recommendations, to ensure that safety and efficiency is maintained.
- Respond promptly to calls from a customer following completion of work, providing advice and assistance by phone and, if necessary, visiting the customer.
- Rectify any installation problems at no cost to the customer during the installer's guarantee period.



\*The use of the word "installer" is not limited to installation itself and covers those carrying out installation, commissioning and/or servicing of heating and hot water products, or the use of supporting products (such as water treatment or test equipment).

\*\*Customer includes householders, landlords and tenants.

# Benchmark Commissioning and servicing section

It is a requirement that the boiler is installed and commissioned to the manufacturers instructions and the data fields on the commissioning checklist completed in full.

To instigate the boiler guarantee the boiler needs to be registered with the manufacturer within one month of the installation.

To maintain the boiler guarantee it is essential that the boiler is serviced annually by a Gas Safe registered engineer who has been trained on the boiler installed. The service details should be recorded on the Benchmark Service Interval Record and left with the householder.



[www.centralheating.co.uk](http://www.centralheating.co.uk)

© Heating and Hotwater Industry Council (HHIC)

# gas BOILER system COMMISSIONING Checklist

This Commissioning Checklist is to be completed in full by the competent person who commissioned the boiler as a means of demonstrating compliance with the appropriate Building Regulations and then handed to the customer to keep for future reference.

Failure to install and commission according to the manufacturer's instructions and complete this Benchmark Commissioning Checklist will invalidate the warranty. This does not affect the customer's statutory rights.

Customer name:				Telephone number:				
Address:								
Boiler make and model:								
Boiler serial number:								
Commissioned by (PRINT NAME):				Gas Safe register number:				
Company name:				Telephone number:				
Company address:								
Commissioning date:								
<b>To be completed by the customer on receipt of a Building Regulations Compliance Certificate*</b>								
Building Regulations Notification Number (if applicable):								
<b>CONTROLS</b> (tick the appropriate boxes)								
Time and temperature control to heating	Room thermostat and programmer/timer		Programmable room thermostat					
	Load/weather compensation		Optimum start control					
Time and temperature control to hot water	Cylinder thermostat and programmer/timer		Combination Boiler					
Heating zone valves	Fitted		Not required					
Hot water zone valves	Fitted		Not required					
Thermostatic radiator valves	Fitted		Not required					
Automatic bypass to system	Fitted		Not required					
Boiler interlock			Provided					
<b>aLL systems</b>								
The system has been flushed and cleaned in accordance with BS7593 and boiler manufacturer's instructions							yes	
What system cleaner was used?								
What inhibitor was used?							Quantity	litres
Has a primary water system filter been installed?							yes	No
<b>CENTRAL HEATING MODE</b> measure and record:								
Gas rate	m <sup>3</sup> /hr	<b>OR</b>	ft <sup>3</sup> /hr					
Burner operating pressure (if applicable)	mbar	<b>OR</b> Gas inlet pressure	mbar					
Central heating flow temperature			°C					
Central heating return temperature			°C					
<b>COMBINATION BOILERS ONLY</b>								
Is the installation in a hard water area (above 200ppm)?							yes	No
If yes, and if required by the manufacturer, has a water scale reducer been fitted?							yes	No
What type of scale reducer has been fitted?								
<b>DOMESTIC HOT WATER MODE</b> Measure and Record:								
Gas rate	m <sup>3</sup> /hr	<b>OR</b>	ft <sup>3</sup> /hr					
Burner operating pressure (at maximum rate)	mbar	<b>OR</b> Gas inlet pressure at maximum rate	mbar					
Cold water inlet temperature			°C					
Hot water has been checked at all outlets		yes	Temperature	°C				
Water flow rate			l/min					
<b>CONDENSING BOILERS ONLY</b>								
The condensate drain has been installed in accordance with the manufacturer's instructions and/or BS5546/BS6798							yes	
<b>aLL INSTALLATIONS</b>								
Record the following:	At max. rate:	CO	ppm	<b>aND</b>	CO/CO <sub>2</sub>	Ratio		
	At min. rate: (where possible)	CO	ppm	<b>aND</b>	CO/CO <sub>2</sub>	Ratio		
The heating and hot water system complies with the appropriate Building Regulations							yes	
The boiler and associated products have been installed and commissioned in accordance with the manufacturer's instructions							yes	
The operation of the boiler and system controls have been demonstrated to and understood by the customer							yes	
The manufacturer's literature, including Benchmark Checklist and Service Record, has been explained and left with the customer							yes	
Commissioning Engineer's Signature								
Customer's Signature								
(To confirm satisfactory demonstration and receipt of manufacturer's literature)								

\* All installations in England and Wales must be notified to Local Authority Building Control (LABC) either directly or through a Competent Persons Scheme. A Building Regulations Compliance Certificate will then be issued to the customer.



# sSERVICE RECORD

It is recommended that your heating system is serviced regularly and that the appropriate service Interval Record is completed.

## service provider

Before completing the appropriate Service Record below, please ensure you have carried out the service as described in the manufacturer's instructions. Always use the manufacturer's specified spare part when replacing controls.

<table border="1" style="width: 100%; border-collapse: collapse;"> <tr> <td colspan="4"><b>sSERVICE 01</b></td> <td colspan="4">Date:</td> </tr> <tr><td colspan="8">Engineer name:</td></tr> <tr><td colspan="8">Company name:</td></tr> <tr><td colspan="8">Telephone No:</td></tr> <tr><td colspan="8">Gas safe register No:</td></tr> <tr> <td rowspan="2">Record:</td> <td>At max. rate:</td> <td>CO</td> <td>ppm</td> <td>aND</td> <td>CO<sub>2</sub></td> <td colspan="2">%</td> </tr> <tr> <td>At min. rate: (Where Possible)</td> <td>CO</td> <td>ppm</td> <td>aND</td> <td>CO<sub>2</sub></td> <td colspan="2">%</td> </tr> <tr><td colspan="8">Comments:</td></tr> <tr><td colspan="8">Signature</td></tr> </table>	<b>sSERVICE 01</b>				Date:				Engineer name:								Company name:								Telephone No:								Gas safe register No:								Record:	At max. rate:	CO	ppm	aND	CO <sub>2</sub>	%		At min. rate: (Where Possible)	CO	ppm	aND	CO <sub>2</sub>	%		Comments:								Signature								<table border="1" style="width: 100%; border-collapse: collapse;"> <tr> <td colspan="4"><b>sSERVICE 02</b></td> <td colspan="4">Date:</td> </tr> <tr><td colspan="8">Engineer name:</td></tr> <tr><td colspan="8">Company name:</td></tr> <tr><td colspan="8">Telephone No:</td></tr> <tr><td colspan="8">Gas safe register No:</td></tr> <tr> <td rowspan="2">Record:</td> <td>At max. rate:</td> <td>CO</td> <td>ppm</td> <td>aND</td> <td>CO<sub>2</sub></td> <td colspan="2">%</td> </tr> <tr> <td>At min. rate: (Where Possible)</td> <td>CO</td> <td>ppm</td> <td>aND</td> <td>CO<sub>2</sub></td> <td colspan="2">%</td> </tr> <tr><td colspan="8">Comments:</td></tr> <tr><td colspan="8">Signature</td></tr> </table>	<b>sSERVICE 02</b>				Date:				Engineer name:								Company name:								Telephone No:								Gas safe register No:								Record:	At max. rate:	CO	ppm	aND	CO <sub>2</sub>	%		At min. rate: (Where Possible)	CO	ppm	aND	CO <sub>2</sub>	%		Comments:								Signature							
<b>sSERVICE 01</b>				Date:																																																																																																																																											
Engineer name:																																																																																																																																															
Company name:																																																																																																																																															
Telephone No:																																																																																																																																															
Gas safe register No:																																																																																																																																															
Record:	At max. rate:	CO	ppm	aND	CO <sub>2</sub>	%																																																																																																																																									
	At min. rate: (Where Possible)	CO	ppm	aND	CO <sub>2</sub>	%																																																																																																																																									
Comments:																																																																																																																																															
Signature																																																																																																																																															
<b>sSERVICE 02</b>				Date:																																																																																																																																											
Engineer name:																																																																																																																																															
Company name:																																																																																																																																															
Telephone No:																																																																																																																																															
Gas safe register No:																																																																																																																																															
Record:	At max. rate:	CO	ppm	aND	CO <sub>2</sub>	%																																																																																																																																									
	At min. rate: (Where Possible)	CO	ppm	aND	CO <sub>2</sub>	%																																																																																																																																									
Comments:																																																																																																																																															
Signature																																																																																																																																															
<table border="1" style="width: 100%; border-collapse: collapse;"> <tr> <td colspan="4"><b>sSERVICE 03</b></td> <td colspan="4">Date:</td> </tr> <tr><td colspan="8">Engineer name:</td></tr> <tr><td colspan="8">Company name:</td></tr> <tr><td colspan="8">Telephone No:</td></tr> <tr><td colspan="8">Gas safe register No:</td></tr> <tr> <td rowspan="2">Record:</td> <td>At max. rate:</td> <td>CO</td> <td>ppm</td> <td>aND</td> <td>CO<sub>2</sub></td> <td colspan="2">%</td> </tr> <tr> <td>At min. rate: (Where Possible)</td> <td>CO</td> <td>ppm</td> <td>aND</td> <td>CO<sub>2</sub></td> <td colspan="2">%</td> </tr> <tr><td colspan="8">Comments:</td></tr> <tr><td colspan="8">Signature</td></tr> </table>	<b>sSERVICE 03</b>				Date:				Engineer name:								Company name:								Telephone No:								Gas safe register No:								Record:	At max. rate:	CO	ppm	aND	CO <sub>2</sub>	%		At min. rate: (Where Possible)	CO	ppm	aND	CO <sub>2</sub>	%		Comments:								Signature								<table border="1" style="width: 100%; border-collapse: collapse;"> <tr> <td colspan="4"><b>sSERVICE 04</b></td> <td colspan="4">Date:</td> </tr> <tr><td colspan="8">Engineer name:</td></tr> <tr><td colspan="8">Company name:</td></tr> <tr><td colspan="8">Telephone No:</td></tr> <tr><td colspan="8">Gas safe register No:</td></tr> <tr> <td rowspan="2">Record:</td> <td>At max. rate:</td> <td>CO</td> <td>ppm</td> <td>aND</td> <td>CO<sub>2</sub></td> <td colspan="2">%</td> </tr> <tr> <td>At min. rate: (Where Possible)</td> <td>CO</td> <td>ppm</td> <td>aND</td> <td>CO<sub>2</sub></td> <td colspan="2">%</td> </tr> <tr><td colspan="8">Comments:</td></tr> <tr><td colspan="8">Signature</td></tr> </table>	<b>sSERVICE 04</b>				Date:				Engineer name:								Company name:								Telephone No:								Gas safe register No:								Record:	At max. rate:	CO	ppm	aND	CO <sub>2</sub>	%		At min. rate: (Where Possible)	CO	ppm	aND	CO <sub>2</sub>	%		Comments:								Signature							
<b>sSERVICE 03</b>				Date:																																																																																																																																											
Engineer name:																																																																																																																																															
Company name:																																																																																																																																															
Telephone No:																																																																																																																																															
Gas safe register No:																																																																																																																																															
Record:	At max. rate:	CO	ppm	aND	CO <sub>2</sub>	%																																																																																																																																									
	At min. rate: (Where Possible)	CO	ppm	aND	CO <sub>2</sub>	%																																																																																																																																									
Comments:																																																																																																																																															
Signature																																																																																																																																															
<b>sSERVICE 04</b>				Date:																																																																																																																																											
Engineer name:																																																																																																																																															
Company name:																																																																																																																																															
Telephone No:																																																																																																																																															
Gas safe register No:																																																																																																																																															
Record:	At max. rate:	CO	ppm	aND	CO <sub>2</sub>	%																																																																																																																																									
	At min. rate: (Where Possible)	CO	ppm	aND	CO <sub>2</sub>	%																																																																																																																																									
Comments:																																																																																																																																															
Signature																																																																																																																																															
<table border="1" style="width: 100%; border-collapse: collapse;"> <tr> <td colspan="4"><b>sSERVICE 05</b></td> <td colspan="4">Date:</td> </tr> <tr><td colspan="8">Engineer name:</td></tr> <tr><td colspan="8">Company name:</td></tr> <tr><td colspan="8">Telephone No:</td></tr> <tr><td colspan="8">Gas safe register No:</td></tr> <tr> <td rowspan="2">Record:</td> <td>At max. rate:</td> <td>CO</td> <td>ppm</td> <td>aND</td> <td>CO<sub>2</sub></td> <td colspan="2">%</td> </tr> <tr> <td>At min. rate: (Where Possible)</td> <td>CO</td> <td>ppm</td> <td>aND</td> <td>CO<sub>2</sub></td> <td colspan="2">%</td> </tr> <tr><td colspan="8">Comments:</td></tr> <tr><td colspan="8">Signature</td></tr> </table>	<b>sSERVICE 05</b>				Date:				Engineer name:								Company name:								Telephone No:								Gas safe register No:								Record:	At max. rate:	CO	ppm	aND	CO <sub>2</sub>	%		At min. rate: (Where Possible)	CO	ppm	aND	CO <sub>2</sub>	%		Comments:								Signature								<table border="1" style="width: 100%; border-collapse: collapse;"> <tr> <td colspan="4"><b>sSERVICE 06</b></td> <td colspan="4">Date:</td> </tr> <tr><td colspan="8">Engineer name:</td></tr> <tr><td colspan="8">Company name:</td></tr> <tr><td colspan="8">Telephone No:</td></tr> <tr><td colspan="8">Gas safe register No:</td></tr> <tr> <td rowspan="2">Record:</td> <td>At max. rate:</td> <td>CO</td> <td>ppm</td> <td>aND</td> <td>CO<sub>2</sub></td> <td colspan="2">%</td> </tr> <tr> <td>At min. rate: (Where Possible)</td> <td>CO</td> <td>ppm</td> <td>aND</td> <td>CO<sub>2</sub></td> <td colspan="2">%</td> </tr> <tr><td colspan="8">Comments:</td></tr> <tr><td colspan="8">Signature</td></tr> </table>	<b>sSERVICE 06</b>				Date:				Engineer name:								Company name:								Telephone No:								Gas safe register No:								Record:	At max. rate:	CO	ppm	aND	CO <sub>2</sub>	%		At min. rate: (Where Possible)	CO	ppm	aND	CO <sub>2</sub>	%		Comments:								Signature							
<b>sSERVICE 05</b>				Date:																																																																																																																																											
Engineer name:																																																																																																																																															
Company name:																																																																																																																																															
Telephone No:																																																																																																																																															
Gas safe register No:																																																																																																																																															
Record:	At max. rate:	CO	ppm	aND	CO <sub>2</sub>	%																																																																																																																																									
	At min. rate: (Where Possible)	CO	ppm	aND	CO <sub>2</sub>	%																																																																																																																																									
Comments:																																																																																																																																															
Signature																																																																																																																																															
<b>sSERVICE 06</b>				Date:																																																																																																																																											
Engineer name:																																																																																																																																															
Company name:																																																																																																																																															
Telephone No:																																																																																																																																															
Gas safe register No:																																																																																																																																															
Record:	At max. rate:	CO	ppm	aND	CO <sub>2</sub>	%																																																																																																																																									
	At min. rate: (Where Possible)	CO	ppm	aND	CO <sub>2</sub>	%																																																																																																																																									
Comments:																																																																																																																																															
Signature																																																																																																																																															
<table border="1" style="width: 100%; border-collapse: collapse;"> <tr> <td colspan="4"><b>sSERVICE 07</b></td> <td colspan="4">Date:</td> </tr> <tr><td colspan="8">Engineer name:</td></tr> <tr><td colspan="8">Company name:</td></tr> <tr><td colspan="8">Telephone No:</td></tr> <tr><td colspan="8">Gas safe register No:</td></tr> <tr> <td rowspan="2">Record:</td> <td>At max. rate:</td> <td>CO</td> <td>ppm</td> <td>aND</td> <td>CO<sub>2</sub></td> <td colspan="2">%</td> </tr> <tr> <td>At min. rate: (Where Possible)</td> <td>CO</td> <td>ppm</td> <td>aND</td> <td>CO<sub>2</sub></td> <td colspan="2">%</td> </tr> <tr><td colspan="8">Comments:</td></tr> <tr><td colspan="8">Signature</td></tr> </table>	<b>sSERVICE 07</b>				Date:				Engineer name:								Company name:								Telephone No:								Gas safe register No:								Record:	At max. rate:	CO	ppm	aND	CO <sub>2</sub>	%		At min. rate: (Where Possible)	CO	ppm	aND	CO <sub>2</sub>	%		Comments:								Signature								<table border="1" style="width: 100%; border-collapse: collapse;"> <tr> <td colspan="4"><b>sSERVICE 08</b></td> <td colspan="4">Date:</td> </tr> <tr><td colspan="8">Engineer name:</td></tr> <tr><td colspan="8">Company name:</td></tr> <tr><td colspan="8">Telephone No:</td></tr> <tr><td colspan="8">Gas safe register No:</td></tr> <tr> <td rowspan="2">Record:</td> <td>At max. rate:</td> <td>CO</td> <td>ppm</td> <td>aND</td> <td>CO<sub>2</sub></td> <td colspan="2">%</td> </tr> <tr> <td>At min. rate: (Where Possible)</td> <td>CO</td> <td>ppm</td> <td>aND</td> <td>CO<sub>2</sub></td> <td colspan="2">%</td> </tr> <tr><td colspan="8">Comments:</td></tr> <tr><td colspan="8">Signature</td></tr> </table>	<b>sSERVICE 08</b>				Date:				Engineer name:								Company name:								Telephone No:								Gas safe register No:								Record:	At max. rate:	CO	ppm	aND	CO <sub>2</sub>	%		At min. rate: (Where Possible)	CO	ppm	aND	CO <sub>2</sub>	%		Comments:								Signature							
<b>sSERVICE 07</b>				Date:																																																																																																																																											
Engineer name:																																																																																																																																															
Company name:																																																																																																																																															
Telephone No:																																																																																																																																															
Gas safe register No:																																																																																																																																															
Record:	At max. rate:	CO	ppm	aND	CO <sub>2</sub>	%																																																																																																																																									
	At min. rate: (Where Possible)	CO	ppm	aND	CO <sub>2</sub>	%																																																																																																																																									
Comments:																																																																																																																																															
Signature																																																																																																																																															
<b>sSERVICE 08</b>				Date:																																																																																																																																											
Engineer name:																																																																																																																																															
Company name:																																																																																																																																															
Telephone No:																																																																																																																																															
Gas safe register No:																																																																																																																																															
Record:	At max. rate:	CO	ppm	aND	CO <sub>2</sub>	%																																																																																																																																									
	At min. rate: (Where Possible)	CO	ppm	aND	CO <sub>2</sub>	%																																																																																																																																									
Comments:																																																																																																																																															
Signature																																																																																																																																															
<table border="1" style="width: 100%; border-collapse: collapse;"> <tr> <td colspan="4"><b>sSERVICE 09</b></td> <td colspan="4">Date:</td> </tr> <tr><td colspan="8">Engineer name:</td></tr> <tr><td colspan="8">Company name:</td></tr> <tr><td colspan="8">Telephone No:</td></tr> <tr><td colspan="8">Gas safe register No:</td></tr> <tr> <td rowspan="2">Record:</td> <td>At max. rate:</td> <td>CO</td> <td>ppm</td> <td>aND</td> <td>CO<sub>2</sub></td> <td colspan="2">%</td> </tr> <tr> <td>At min. rate: (Where Possible)</td> <td>CO</td> <td>ppm</td> <td>aND</td> <td>CO<sub>2</sub></td> <td colspan="2">%</td> </tr> <tr><td colspan="8">Comments:</td></tr> <tr><td colspan="8">Signature</td></tr> </table>	<b>sSERVICE 09</b>				Date:				Engineer name:								Company name:								Telephone No:								Gas safe register No:								Record:	At max. rate:	CO	ppm	aND	CO <sub>2</sub>	%		At min. rate: (Where Possible)	CO	ppm	aND	CO <sub>2</sub>	%		Comments:								Signature								<table border="1" style="width: 100%; border-collapse: collapse;"> <tr> <td colspan="4"><b>sSERVICE 10</b></td> <td colspan="4">Date:</td> </tr> <tr><td colspan="8">Engineer name:</td></tr> <tr><td colspan="8">Company name:</td></tr> <tr><td colspan="8">Telephone No:</td></tr> <tr><td colspan="8">Gas safe register No:</td></tr> <tr> <td rowspan="2">Record:</td> <td>At max. rate:</td> <td>CO</td> <td>ppm</td> <td>aND</td> <td>CO<sub>2</sub></td> <td colspan="2">%</td> </tr> <tr> <td>At min. rate: (Where Possible)</td> <td>CO</td> <td>ppm</td> <td>aND</td> <td>CO<sub>2</sub></td> <td colspan="2">%</td> </tr> <tr><td colspan="8">Comments:</td></tr> <tr><td colspan="8">Signature</td></tr> </table>	<b>sSERVICE 10</b>				Date:				Engineer name:								Company name:								Telephone No:								Gas safe register No:								Record:	At max. rate:	CO	ppm	aND	CO <sub>2</sub>	%		At min. rate: (Where Possible)	CO	ppm	aND	CO <sub>2</sub>	%		Comments:								Signature							
<b>sSERVICE 09</b>				Date:																																																																																																																																											
Engineer name:																																																																																																																																															
Company name:																																																																																																																																															
Telephone No:																																																																																																																																															
Gas safe register No:																																																																																																																																															
Record:	At max. rate:	CO	ppm	aND	CO <sub>2</sub>	%																																																																																																																																									
	At min. rate: (Where Possible)	CO	ppm	aND	CO <sub>2</sub>	%																																																																																																																																									
Comments:																																																																																																																																															
Signature																																																																																																																																															
<b>sSERVICE 10</b>				Date:																																																																																																																																											
Engineer name:																																																																																																																																															
Company name:																																																																																																																																															
Telephone No:																																																																																																																																															
Gas safe register No:																																																																																																																																															
Record:	At max. rate:	CO	ppm	aND	CO <sub>2</sub>	%																																																																																																																																									
	At min. rate: (Where Possible)	CO	ppm	aND	CO <sub>2</sub>	%																																																																																																																																									
Comments:																																																																																																																																															
Signature																																																																																																																																															

\* Allinstallations in England and Wales must be notified to Local Authority Building Control (LABC) either directly or through a Competent Persons Scheme. A Building Regulations Compliance Certificate will then be issued to the customer.



# FLOWCHART FOR CO LEVEL AND COMBUSTION RATIO CHECK ON COMMISSIONING A CONDENSING BOILER

## Important preliminary Information on Checks

The air gas ratio valve is factory-set and must not be adjusted DURING COMMISSIONING.

If the boiler requires conversion to operate with a different gas family (e.g. conversion from natural gas to LPG) separate guidance is provided with the conversion kit supplied and this must be followed.

### pRIOR TO CO LEVEL AND COMBUSTION RATIO CHECK

The installation instructions must have been followed, gas type verified and gas supply pressure / gas rate checked as required prior to commissioning.

As part of the installation process, ESPECIALLY WHERE A FLUE HAS BEEN FITTED BY PERSONS OTHER THAN THE BOILER INSTALLER, visually check the integrity of the whole flue system to confirm that all components are correctly assembled, fixed and supported. Check that maximum flue lengths have not been exceeded and all guidance has been followed (e.g. Gas Safe Register Technical Bulletin (TB) 008 where chimney/flues are in voids).

The ECGA should be of the correct type, as specified by BS 7967.

Prior to its use, the ECGA should have been maintained and calibrated as specified by the manufacturer. The installer must have the relevant competence for use of the analyser.

Check and zero the analyser IN FRESH AIR in accordance with the analyser manufacturer's instructions.

KEy:

**CO** = carbon monoxide

**CO<sub>2</sub>** = carbon dioxide

**O<sub>2</sub>** = oxygen

**Combustion Ratio** = The CO reading measured in ppm divided by the CO<sub>2</sub> reading first converted to ppm

**ppm** = parts per million

**gs(I&U)R** = Gas Safety (Installation and Use) Regulations

### \*setting to Minimum Rate:

1. Turn the CH temperature control knob into the 10 O'clock position.
2. Create a heat demand by ensuring that the system controls are requesting heat and the boiler Mode Knob is in the On Position.
3. Within an overall time of 3 seconds, turn the CH temperature control knob fully clockwise, back to 10 O'clock and then fully clockwise again.
4. "S" will be shown on the display and the boiler output will be reduced to minimum.
5. The boiler will remain at minimum rate for 5 minutes before reverting to normal operation.

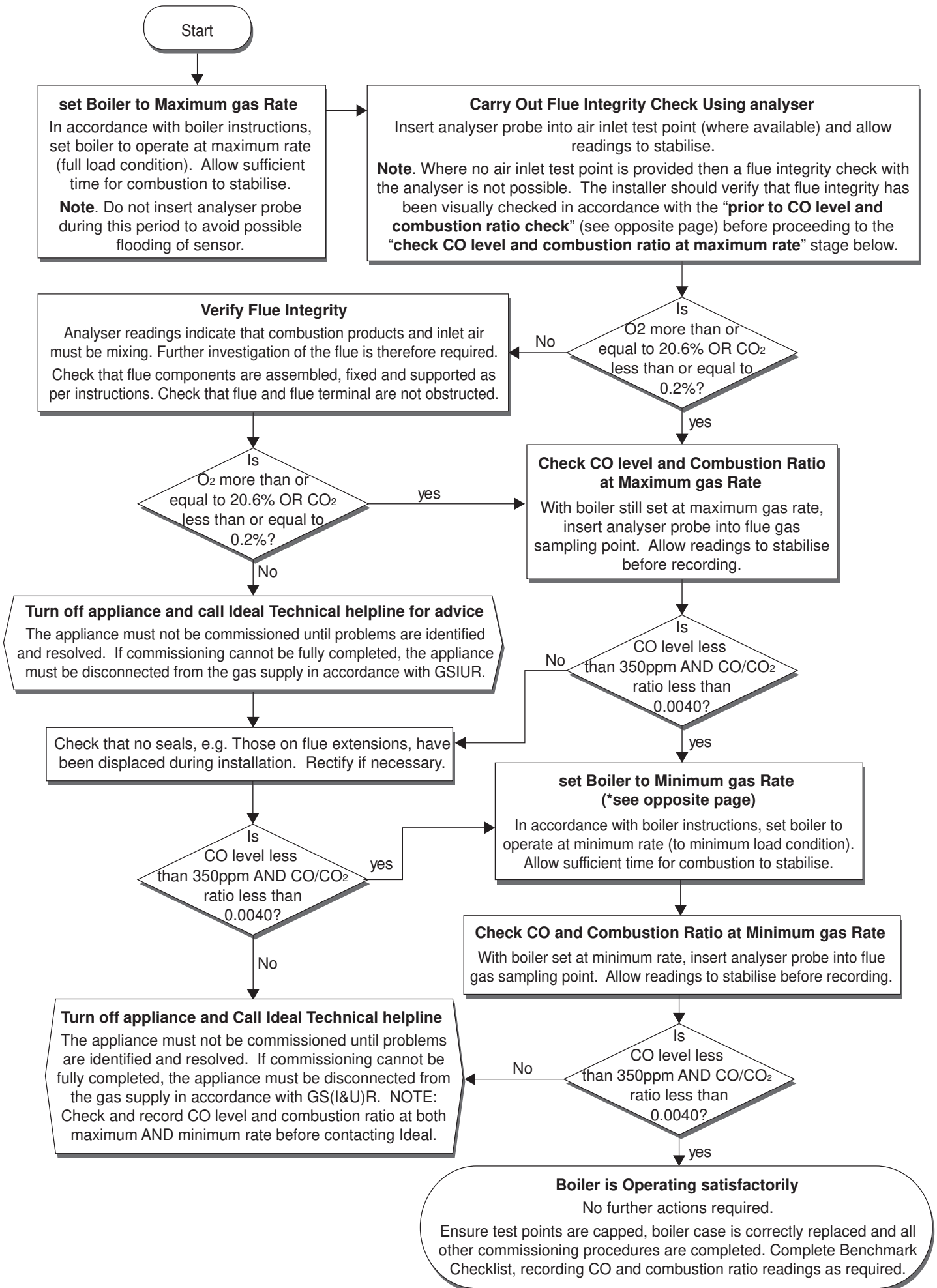

For additional fault finding advice please visit Ideal's website

[www.idealboilers.com](http://www.idealboilers.com)

### Technical Training

The Ideal Technical Training Centre offers a series of first class training courses for domestic, commercial and industrial heating installers, engineers and system specifiers. For details of courses please ring:..... 01482 498 432



*The code of practice for the installation, commissioning & servicing of central heating systems*



FM 59915

Manufactured under an ISO 9001 registered quality management system

**Ideal Boilers Ltd.**, P.O. Box 103, National Ave, Kingston upon Hull, HU5 4JN. Telephone: 01482 492 251 Fax: 01482 448 858. Registration No. London 322 137.

**Ideal stelrad group** pursues a policy of continuing improvement in the design and performance of its products. The right is therefore reserved to vary specification without notice.



Ideal Stelrad Group

***Ideal Technical Helpline: 01482 498 663***

***[www.idealboilers.com](http://www.idealboilers.com)***

# USERS GUIDE

---

## LOGIC Heat 12, 15, 18, 24, 30

For installation guide see reverse of book



When replacing any part on this appliance, use only spare parts that you can be assured conform to the safety and performance specification that we require. Do not use reconditioned or copy parts that have not been clearly authorised by Ideal.

# FOR aNy qUERIEs pLEaSE RING ThE IDEaL CONsUMER hELpLINE : 01482 498660

## NOTE. BOILER REsET pROCEDURE -

To reset boiler, turn mode control knob to reset position and immediately turn knob back to required setting.

## Introduction

The **Logic heat** is a wall mounted, room sealed, condensing heating only boiler, featuring full sequence automatic spark ignition and fan assisted combustion.

Due to the high efficiency of the boiler, condensate is produced from the flue gases and this is drained to a suitable disposal point through a plastic waste pipe at the base of the boiler. A condensate 'plume' will also be visible at the flue terminal.

## safety

### current gas safety (installation & use) regulations or rules in force.

In your own interest, and that of safety, it is the law that this boiler must be installed by a Gas Safe Registered Engineer, in accordance with the above regulations.

In IE, the installation must be carried out by a Registered Gas Installer (RGII) and installed in accordance with the current edition of I.S. 813 "Domestic Gas Installations", the current Building Regulations and reference should be made to the current ETCI rules for electrical installation.

*It is essential that the instructions in this booklet are strictly followed, for safe and economical operation of the boiler.*

## electricity supply

**This appliance must be earthed.**

supply: 230 V ~ 50 hz. The fusing should be 3a.

## important notes

- This appliance must not be operated without the casing correctly fitted and forming an adequate seal.
- If the boiler is installed in a compartment then the compartment MUST NOT be used for storage purposes.
- If it is known or suspected that a fault exists on the boiler then it MUST NOT BE USED until the fault has been corrected by a Gas Safe Registered Engineer or in IE a Registered Gas Installer (RGII).
- Under NO circumstances should any of the sealed components on this appliance be used incorrectly or tampered with.
- This appliance is not intended for use by persons (including children) with reduced physical, sensory or mental capabilities, or lack of experience and knowledge, unless they have been given supervision or instructions concerning use of the appliance by a person responsible for their safety.
- Children should be supervised to ensure that they do not play with the appliance.

In cases of repeated or continuous shutdown a Gas Safe Registered Engineer or in IE a Registered Gas Installer (RGII) should be called to investigate and rectify the condition causing this and carry out an operational test. Only the manufacturers original parts should be used for replacement.

## minimum clearances

Clearances of **100mm (4")** above, **100mm (4")** below, **2.5mm (1/8")** at the sides and **450mm (17 3/4")** at the front of the boiler casing must be allowed for servicing.

## Bottom clearance

Bottom clearance after installation can be reduced to 5mm.

This must be obtained with an easily removable panel, to enable the consumer to view the system pressure gauge, and to provide the 100mm clearance required for servicing.

## To light the boiler. refer to Frame 1

If a programmer is fitted refer to separate instructions for the programmer before continuing.

1. CHECK THAT THE ELECTRICITY SUPPLY TO BOILER IS OFF.
2. Set the mode control knob (B) to 'Off'.
3. Set the Heating temperature control (A) to 'max'.
4. Switch ON electricity to the boiler and check that all external controls, e.g. programmer, room thermostat and cylinder thermostat, are ON.
5. Set the mode control knob to ON.

The boiler will commence the ignition sequence supplying heat to the central heating, if required.

**Note.** In normal operation the boiler status display (C) will show codes:

**D**

Standby - no demand for heat.

**E**  
**F**

Heat being supplied.

Boiler frost protection - boiler will fire if temperature is below 5 degrees C.

During normal operation the burner on indicator (D) will remain illuminated when the burner is lit.

Note: If the boiler fails to light after five attempts the fault code **L-2** will be displayed.

## REsET pROCEDURE

To reset boiler, turn the mode control knob (B) to reset position and immediately turn knob back to ON. The boiler will repeat the ignition sequence. If the boiler still fails to light consult a Gas Safe Registered Engineer or in IE a Registered Gas Installer (RGII).

All Gas Safe Register installers carry a Gas Safe Register ID card, and have a registration number. Both should be recorded in the Benchmark Commissioning Checklist. you can check your installer by calling Gas Safe Register direct on 0800 4085500.

**Ideal stelrad group** is a member of the Benchmark scheme and fully supports the aims of the programme. Benchmark has been introduced to improve the standards of installation and commissioning of central heating systems in the UK and to encourage the regular servicing of all central heating systems to ensure safety and efficiency.

**ThE BENCHMaRK sERVICE INTERV aL RECORD MUSt BE COMPLETED aFTER EaCh sERVICE**



## operation

### control of Water Temperature

The boiler controls the central heating radiator temperature to a maximum of 80°C, adjustable via the temperature control (A).

The Logic Heat is a high efficiency condensing boiler which is most efficient when operating in condensing mode.

The boiler will operate in this mode if the temperature control (A) is set to the 'e' position (economy mode). This control should be set to maximum for very cold periods

### Weather compensation

When the Weather Compensation option is fitted to the system then the CH Temperature Control (A) becomes a method of controlling room temperature. Turn the knob clockwise to increase room temperature and anti-clockwise to decrease room temperature. Once the desired setting has been achieved, leave the knob in this position and the system will automatically achieve the desired room temperature for all outside weather conditions.

### To shut down the boiler

Set the mode control knob to OFF.

### To relight the boiler

Repeat the procedure detailed in 'To light the boiler'.

### Frost protection

If no system frost protection is provided and frost is likely during a short absence from home, leave the heating controls (if fitted) at a reduced temperature setting. For longer periods, the entire system should be drained.

If the system includes a frost thermostat then, during cold weather, the boiler should be turned OFF at the time switch (if fitted) ONLY. The mains supply should be left switched ON, with the boiler thermostat left in the normal running position.

### Boiler Overheat Protection

The boiler controls will shut down the boiler in the event of overheating. Should this occur, a fault code L-1 will be displayed. Refer to fault chart.

### Flame Failure

Should this occur a fault code L-2 will be displayed. Refer to fault chart.

## 1 boiler controls

### Legend

- a. Temperature Control
- B. Mode Control
- C. Boiler Status
- D. Burner 'on' Indicator
- E. Condensate Drain
- F. Economy Mode

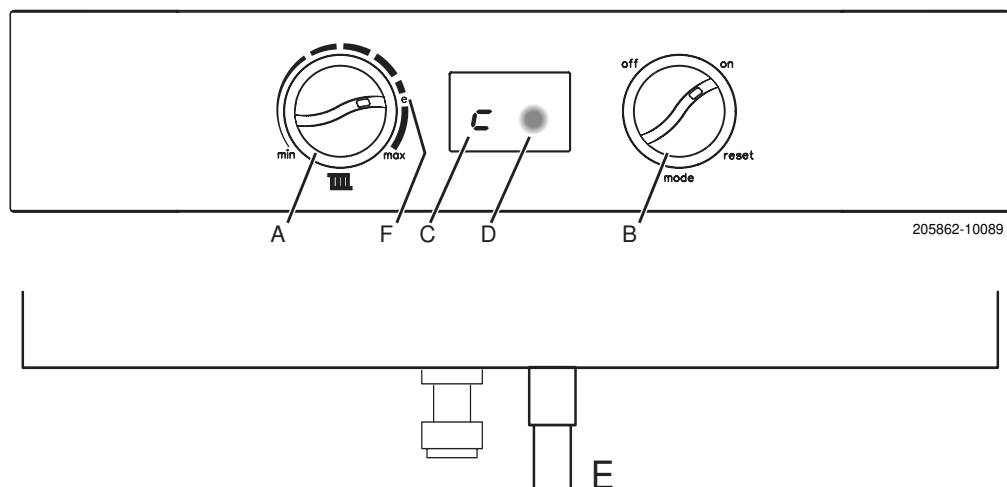

## **Condensate Drain**

This appliance is fitted with a siphonic condensate trap system that reduces the risk of the appliance condensate from freezing. However should the condensate pipe to this appliance freeze, please follow these instructions:

- a. If you do not feel competent to carry out the defrosting instructions below please call your local Gas Safe Registered installer for assistance.
- b. If you do feel competent to carry out the following instructions please do so with care when handling hot utensils. Do not attempt to thaw pipework above ground level.

If this appliance develops a blockage in its condensate pipe, its condensate will build up to a point where it will make a gurgling noise prior to locking out an "L2" fault code. If the appliance is reset it will make a gurgling noise prior to it locking out on a failed ignition "L2" code.

To unblock a frozen condensate pipe;

1. Follow the routing of the plastic pipe from its exit point on the appliance, through its route to its termination point.  
Locate the frozen blockage. It is likely that the pipe is frozen at the most exposed point external to the building or where there is some obstruction to flow. This could be at the open end of the pipe, at a bend or elbow, or where there is a dip in the pipe in which condensate can collect. The location of the blockage should be identified as closely as possible before taking further action.
2. Apply a hot water bottle, microwaveable heat pack or a warm damp cloth to the frozen blockage area. Several applications may have to be made before it fully defrosts. Warm water can also be poured onto the pipe from a watering can or similar. **DO NOT** use boiling water.
3. Caution when using warm water as this may freeze and cause other localised hazards.
4. Once the blockage is removed and the condensate can flow freely, reset the appliance. (Refer to "To Light the boiler")
5. If the appliance fails to ignite, call your Gas Safe Registered engineer.

### **preventative solutions**

During cold weather, set the boiler stat to maximum, (Must return to original setting once cold spell is over)

Place the heating on continuous and turn the room stat down to 15°C overnight or when unoccupied. (Return to normal after cold spell).

## **escape of gas**

Should a gas leak or fault be suspected contact the National Gas Emergency Service without delay. **Telephone 0800 111 999**

**Do NOT search for gas leaks with a naked flame.**

## **cleaning**

For normal cleaning simply dust with a dry cloth.

To remove stubborn marks and stains, wipe with a damp cloth and finish off with a dry cloth.

**DO NOT use abrasive cleaning materials.**

## **maintenance**

The appliance should be serviced at least once a year by a Gas Safe Registered Engineer or in IE a Registered Gas Installer (RGII).

# pOINTs FOR ThE BOILER UsER

**Note.** In line with our current warranty policy we would ask that you check through the following guide to identify any problems external to the boiler prior to requesting a service engineers visit. Should the problem be found to be other than with the appliance we reserve the right to levy a charge for the visit, or for any pre-arranged visit where access is not gained by the engineer.

## TROUBLEshOOTING

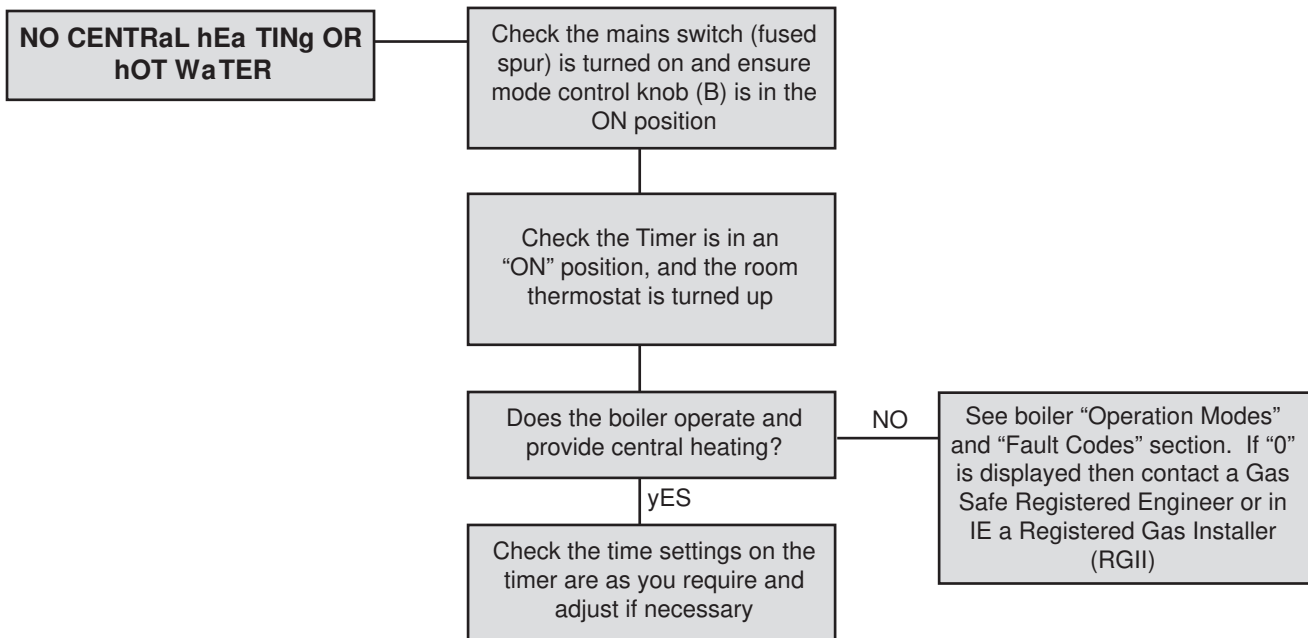

## OpERaTION MODEs

Display CODE ON BOILER	DEsCRIPtION
	The boiler is in standby mode awaiting either a central heating call or hot water demand.
	The boiler has a call for heating but the appliance has reached the desired temperature set on the boiler.
	The boiler is operating in heating mode.
	The boiler is operating in frost mode.

continued . . . . .

# FaULT CODEs

Display	CODE ON BOILER	DEsCRIPtION	aCTION
		BCC Activation Fault	Reset the appliance - if the boiler fails to operate then please contact Ideal (if under warranty) or alternatively a Gas Safe Registered Engineer if outside of the warranty period. In IE contact a Registered Gas Installer (RGII).
		BCC Fault	
		Unconfigured PCB	Reset the appliance - if the boiler fails to operate then please contact Ideal (if under warranty) or alternatively a Gas Safe Registered Engineer if outside of the warranty period. In IE contact a Registered Gas Installer (RGII).
		Flame Loss	See Action - Fault Code L 2
		Fan Fault	Reset the appliance - if the boiler fails to operate then please contact Ideal (if under warranty) or alternatively a Gas Safe Registered Engineer if outside of the warranty period. In IE contact a Registered Gas Installer (RGII).
		Flow Thermistor	Reset the appliance - if the boiler fails to operate then please contact Ideal (if under warranty) or alternatively a Gas Safe Registered Engineer if outside of the warranty period. In IE contact a Registered Gas Installer (RGII).
		Return Thermistor	Reset the appliance - if the boiler fails to operate then please contact Ideal (if under warranty) or alternatively a Gas Safe Registered Engineer if outside of the warranty period. In IE contact a Registered Gas Installer (RGII).
		Outside Sensor Failure	Reset the appliance - if the boiler fails to operate then please contact Ideal (if under warranty) or alternatively a Gas Safe Registered Engineer if outside of the warranty period. In IE contact a Registered Gas Installer (RGII).
		Low Mains Voltage	Contact a qualified electrician or your electricity provider.
		PCB Fault	Please contact Ideal (if under warranty) or alternatively a Gas Safe Registered Engineer if outside of the warranty period. In IE contact a Registered Gas Installer (RGII).
		Flow/Return Reversed	Please contact a Gas Safe Registered Engineer. In IE contact a Registered Gas Installer (RGII).
		No Water Flow	Please contact Ideal (if under warranty) or alternatively a Gas Safe Registered Engineer if outside of the warranty period. In IE contact a Registered Gas Installer (RGII).
		Flow Temperature Overheat or Unconfigured PCB	Check system pressure is between 1 & 1.5bar on the pressure gauge. If the boiler fails to operate then please contact Ideal (if under warranty) or alternatively a Gas Safe Registered Engineer if outside of the warranty period. In IE contact a Registered Gas Installer (RGII).
		Ignition Lockout	1. Check other gas appliances in the house are working to confirm a supply is present in the property. 2. If other appliances do not work or there are no other appliances, check the gas supply is on at the meter and/or pre payment meter has credit. If the boiler fails to operate then please contact Ideal (if under warranty) or alternatively a Gas Safe Registered engineer if outside of the warranty period. In IE contact a Registered Gas Installer (RGII).
		5 Boiler Resets in 15 minutes	1. Turn power off and on at the fused spur. 2. If the boiler fails to operate please contact Ideal (if under warranty) or alternatively a Gas Safe Registered Engineer if outside of the warranty period. In IE contact a Registered Gas Installer (RGII).
		False Flame Lockout	Reset the appliance - if the boiler fails to operate then please contact Ideal (if under warranty) or alternatively a Gas Safe Registered Engineer if outside of the warranty period. In IE contact a Registered Gas Installer (RGII).



**Ideal Consumer Helpline**  
Tel: 01482 498660  
www.idealboilers.com

**Ideal stelrad group** pursues a policy of continuing improvement in the design and performance of its products. The right is therefore reserved to vary specification without notice.

**Ideal**, P.O. Box 103, National Ave, Kingston Upon Hull, HU5 4JN.  
Tel. 01482 492251 Fax. 01482 448858. Registration No. London 322 137.

