

INSTALLATION AND SERVICING

LOGIC + Combi
24, 30, 35



For details of document amendments, refer to page 3

When replacing any part on this appliance, use only spare parts that you can be assured conform to the safety and performance specification that we require. Do not use reconditioned or copy parts that have not been clearly authorised by Ideal.

For the very latest copy of literature for specification and maintenance practices visit our website www.idealheating.com where you can download the relevant information in PDF format.

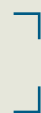

NOTES FOR THE INSTALLER

**FOR ANY TECHNICAL QUERIES PLEASE RING THE IDEAL
INSTALLER/TECHNICAL HELPLINE : 01482 445570**

NOTE. BOILER RESET PROCEDURE -

To reset boiler, turn mode knob to reset position and immediately turn knob back to required setting.
The boiler will repeat the ignition sequence.

DOCUMENT AMENDMENTS

Relevant Installation changes implemented in this book from Mod Level..... A03 (Feb 10) to A04 (Oct 10)

Various updates throughout the book referencing the new Ideal Branding.

Page 4, Table 2

New Sedbuk 2009 figures

Page 5, Boiler PI No.

New PI numbers

Page 6, Operation, paragraph 2

Temperature change to 45°C (was 30°C)

Page 7, Optional Extra Kits

Horizontal Flue Terminal added

Page 8, Gas Supply

New graph added - Gas Cock Pressure Drop

Page 8, Flue Installation

New "IMPORTANT" note added.

Page 9, Electrical Supply

New paragraph two added.

Page 10, Frame 1 Boiler Dimensions, Services & Clearances

"Rear Flue Only" updated to 165mm (was 145mm). "Side Flue Only" - Top Clearance updated to 165mm (was 160mm)

Page 12, Frame 3 System Requirements

IMPORTANT note updated. Also Note added at bottom of Frame.

Page 12, Frame 5 Water Treatment

Addition of Scalemaster Gold 100

Page 13, Frame 6 Boiler Assy

Addition of Note Ref to BCC Card.

Page 14, Frame 7 Unpacking

Pack A Contents - New item H added.

Hardware Pack - updated Filling Loop contents

Page 24, Frame 24 Connecting the Flue to the Boiler

Note added ref Side Flue

Key no. 4 updated ref flue seal.

Page 28, Frame 29 Connections and Filling

Frames condensed into one (Water Connections DHW & CH, Gas Connection, Safety Valve Drain & Filling)

Page 32, Frame 35 Wiring Diagram

New Updated Wiring Diagram

Page 33, Frame 36 Commissioning & Testing

Addition of "General" & "Attention" note.

Page 37, Frame 40 General Checks

Table updated "Water Temperatures"

Page 39, Frame 42 Servicing Schedule

Item no. 10 updated and addition of "General"

Page 48, Frame 60 Main PCB Replacement

Addition of Note ref to BCC.

Page 54, Frame 74 Heat Engine Renewal

Item 15 & 16 updated.

Page 56, Frame 77 Fault Finding Chart Main Menu

Addition of Note ref to BCC

Page 57, Frame 79 Ignition Lockout

Updated Fault Finding Chart

Page 62, Frame 90 No CH Operation But HW OK

Updated Fault Finding Chart

Page 64, Short List of Parts

Note added ref to Boiler Assy Diagrams

Part no's updated & new parts added

Note added ref to BCC

Short List of Parts diagrams

Page deleted refer to Boiler Assembly Frame

Installer Notification Guidelines

Page deleted

Page 66 - 67 Commissioning Checklist

Forms updated

Boiler Guarantee

Page deleted. Now found in Guarantee /Registration Pack

Ideal Stelrad Group reserve the right to vary specification without notice

GENERAL

Table 1 - General Data

| Ideal Logic + Combi | | 24 | 30 | 35 |
|--|--------------------------------|---|--------------|--------------|
| Gas supply | | 2H - G20 - 20mbar | | |
| Gas Supply Connection | | 15mm copper compression | | |
| Injector Size | (mm) | 4.15 | 4.65 | 4.9 |
| Inlet Connection | Domestic Hot Water | 15mm copper compression | | |
| Outlet Connection | Domestic Hot Water | 15mm copper compression | | |
| Flow Connection | Central Heating | 22mm copper compression | | |
| Return Connection | Central Heating | 22mm copper compression | | |
| Flue Terminal Diameter | mm (in) | 100 (4) | | |
| Average Flue Temp-Mass Flow Rate | (DHW) | 63°C - 11g/s | 68°C - 13g/s | 73°C - 15g/s |
| Maximum Working Pressure (Sealed Systems) | bar (lb/in ²) | 2.5 (36.3) | | |
| Maximum Domestic Hot Water Inlet Pressure | bar (lb/in ²) | 10.0 (145) | | |
| Minimum Domestic Hot Water Inlet Pressure* | bar (lb/in ²) | 0.8 (11.6) | 1.3 (18.9) | 1.3 (18.9)** |
| Electrical Supply | | 230 V ~ 50 Hz. | | |
| Power Consumption | W | 146 | 152 | 177 |
| Fuse Rating | | External : 3A Internal : T4H HRC L250 V | | |
| Water content | Central Heating litre (gal) | 1.2 (0.26) | | |
| | Domestic Hot Water litre (gal) | 0.5 (0.11) | | |
| Packaged Weight | kg (lb) | 37.7 (83.1) | 37.8 (83.3) | 38 (83.8) |
| Maximum Installation Weight | kg (lb) | 32.7 (72.1) | 32.8 (72.3) | 33 (72.8) |
| Boiler Casing Size | Height | 700 (27.5) | | |
| | Width | 395 (15.5) | | |
| | Depth | 278 (11) | | |

*Required for maximum flow rate. Boiler operates down to 2 l/min DHW delivery

** In areas of low water pressure the DHW restrictor can be removed

Table 2 - Performance Data - Central Heating

| Boiler Input : | | Max. | Min. | | | |
|----------------------|-----------------------|----------------------|----------|----------|----------|----------|
| | | | 24 | 30 | 35 | |
| Boiler Input 'Q' | Nett CV | kW | 24.3 | 4.9 | 6.1 | 7.1 |
| | | (Btu/h) | (82,900) | (16,600) | (20,700) | (24,100) |
| | Gross CV | kW | 27.0 | 5.4 | 6.7 | 7.9 |
| | | (Btu/h) | (92,000) | (18,400) | (23,000) | (26,900) |
| Gas Consumption | | l/s | 0.698 | 0.139 | 0.173 | 0.204 |
| | | (ft ³ /h) | (89) | (17.8) | (22) | (25.9) |
| Boiler Output : | | | | | | |
| Non Condensing | | kW | 24.2 | 4.8 | 6.1 | 7.1 |
| | 70°C Mean Water temp. | (Btu/h) | (82,600) | (16,500) | (20,700) | (24,100) |
| Condensing | | kW | 25.6 | 5.1 | 6.4 | 7.5 |
| | 40°C Mean Water temp. | (Btu/h) | (87,400) | (17,500) | (21,800) | (25,500) |
| Seasonal efficiency* | SEDBUK 2005 | | 91% | 91.1% | 91% | |
| Seasonal efficiency* | SEDBUK 2009 | | 88.9% | 89% | 89% | |
| NOx Classification | | | CLASS 5 | | | |

Table 3 - Performance Data - Domestic Hot Water

| Maximum DHW Input : | | 24 | 30 | 35 |
|-----------------------------------|----------------------|----------|-----------|-----------|
| Nett CV | kW | 24.3 | 30.4 | 35.4 |
| | (Btu/h) | (82,900) | (103,600) | (120,900) |
| Gross CV | kW | 27.0 | 33.7 | 39.3 |
| | (Btu/h) | (92,000) | (115,000) | (134,200) |
| Gas Consumption | l/s | 0.698 | 0.871 | 1.016 |
| | (ft ³ /h) | (89) | (111) | (129) |
| Maximum DHW Output | kW | 24.2 | 30.3 | 35.3 |
| | (Btu/h) | (82,600) | (103,300) | (120,500) |
| DHW Flow Rate at 35°C temp. rise. | l/min | 9.9 | 12.4 | 14.5 |
| | (gpm) | (2.2) | (2.8) | (3.2) |
| DHW Specific Rate | l/min | 11.5 | 14.5 | 16.9 |
| | (gpm) | (2.5) | (3.2) | (3.7) |

* The value is used in the UK Government's Standard Assessment Procedure (SAP) for energy rating of dwellings. The test data from which it has been calculated have been certified by a notified body.

Note. Gas consumption is calculated using a calorific value of 38.7 MJ/m³ (1038 Btu/ft³) gross or 34.9 MJ/m³ (935 Btu/ft³) nett

To obtain the gas consumption at a different calorific value:

- For l/s - divide the gross heat input (kW) by the gross C.V. of the gas (MJ/m³)
- For ft³/h - divide the gross heat input (Btu/h) by the gross C.V. of the gas (Btu/ft³)

Key to symbols

GB = United Kingdom **IE** = Ireland (Countries of destination)

PMS = Maximum operating pressure of water

C₁₃ C₃₃ C₅₃ = A room sealed appliance designed for connection via ducts to a horizontal or vertical terminal, which admits fresh air to the burner and discharges the products of combustion to the outside through orifices which, in this case, are concentric. The fan is up stream of the combustion chamber.

I_{2H} = An appliance designed for use on 2nd Family gas, Group H only.

GENERAL

IDEAL LOGIC + COMBI

Natural Gas only

| Boiler size | G.C. Appliance No. (Benchmark No.) | PI No. |
|-------------|---------------------------------------|----------|
| 24 | 47-348-65 | 86 CL 08 |
| 30 | 47-348-66 | 86 CL 08 |
| 35 | 47-348-67 | 86 CL 08 |

Destination Country: GB, IE

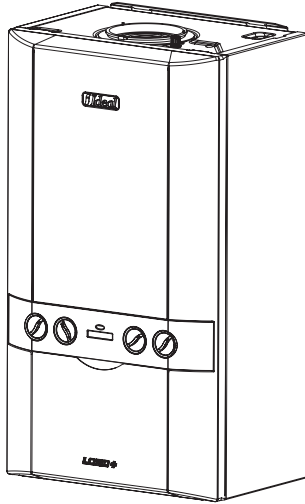

CONTENTS

| | |
|---|---------------|
| Air Supply | 9 |
| Benchmark Commissioning Checklist | 66 |
| Boiler Clearances | 10 |
| Boiler Exploded Diagram | 13 |
| Condensate Drain | 9, 22, 23, 41 |
| Electrical Connections | 29 |
| Electrical Supply | 9 |
| Extension Ducts - Fitting | 20,21 |
| Fault Finding | 56-63 |
| Flue Fitting | 16 |
| Flue Installation | 8 |
| Gas Safety Regulations | 7 |
| Gas Supply | 8 |
| Installation | 13-38 |
| Pump | 70 |
| Safe Handling | 6 |
| Servicing | 39-55 |
| Short List of Parts | 64 |
| Thermostatic Radiator Valves | 9 |
| Water and Systems | 9,11,12 |
| Water & Gas Connections | 28 |
| Water Treatment | 12 |
| Wiring Diagram | 32 |

For GB, to comply with Building Regulations Part L1 (Part 6 in Scotland) the boiler should be fitted in accordance with the manufacturer's instructions. Self-certification that the boiler has been installed to comply with Building Regulations can be demonstrated by completing and signing the Benchmark Commissioning Checklist.

Before installing this boiler, read the Code of Practice sheet at the rear of this book.

BENCHMARK COMMISSIONING CHECKLIST DETAILS

| Boiler | Page | | Page |
|---|--------------------|--|--------------------|
| Make and model..... | 5 | Burner operating pressure | n/a |
| Appliance serial no. on data badge | Front Cover | Central heating flow temp. | measure and record |
| SEDBUK No. %..... | 4 | Central heating return temp. | measure and record |
| Controls | | For combination boilers only | |
| Time and temperature control to heating | 30 | Scale reducer..... | 11 |
| Time and temperature control to hot water | 30 | <i>Hot water mode</i> | |
| Heating zone valves..... | n/a | Heat input..... | to be calculated |
| TRV's..... | 9 | Max. operating burner pressure | n/a |
| Auto bypass | 9 | Max. operating water pressure..... | measure & record |
| Boiler interlock..... | 9 | Cold water inlet temp | measure & record |
| For | all boilers | Hot water outlet temp | measure & record |
| Flushing to BS.7593..... | 12 | Water flow rate at max. setting..... | measure & record |
| Inhibitor | 12 | For condensing boilers only | |
| <i>Central heating mode</i> | | Condensate drain..... | 22 |
| Heat input..... | to be calculated | For all boilers: complete, sign & hand over to customer | |

For assistance see Technical Helpline on the back page

NOTE TO THE INSTALLER: COMPLETE THE BENCHMARK COMMISSIONING CHECKLIST AND LEAVE THESE INSTRUCTIONS WITH APPLIANCE



INTRODUCTION

The **Logic + Combi** range of boilers are wall mounted, full sequence, automatic spark ignition, low water content, fanned flue, high efficiency, condensing, combination gas boilers.

Note. *Due to the high efficiency of the boiler a plume of water vapour will form at the terminal during operation.*

Central heating (CH) output is fully modulating with a range of:

| | |
|----|--|
| 24 | 4.8 to 24.2kW (16,500 to 82,600 Btu/h) |
| 30 | 6.1 to 24.2kW (20,700 to 82,600 Btu/h) |
| 35 | 7.1 to 24.2kW (24,100 to 82,600 Btu/h) |

Instantaneous domestic hot water (DHW) output is also fully modulating with a maximum of :

| | |
|----|------------------------|
| 24 | 24.2kW (82,600 Btu/h) |
| 30 | 30.3kW (103,300 Btu/h) |
| 35 | 35.3kW (120,500 Btu/h) |

The boiler is supplied fully assembled with DHW plate heat exchanger, diverter valve, circulating pump, pressure gauge, safety valve and CH expansion vessel.

Variable CH and DHW temperature controls are fitted on the user control and the boiler features a DHW preheat facility.

The boiler includes as standard:

- Automatic bypass
- Boiler frost protection
- Daily pump and diverter valve exercise.

The boiler casing is of white painted mild steel.

The boiler temperature controls are visible located in the control panel on the front of the boiler.

The heat exchanger is manufactured from cast aluminium.

The boiler is suitable for connection to fully pumped, sealed heating systems ONLY. Adequate arrangements for completely draining the system by provision of drain cocks MUST be provided in the installation pipework.

Pipework from the boiler is routed downwards.

OPERATION

With no demand for CH, the boiler fires only when DHW is drawn off, or periodically for a few seconds without any DHW draw-off, in order to maintain the DHW calorifier in a heated condition. This only occurs if pre-heat knob is in the 'ON' period.

When there is a demand for CH, the heating system is supplied at the selected temperature of between 45°C and 80°C, until DHW is drawn off. The full output from the boiler is then directed via the diverter valve to the plate heat exchanger to supply a nominal DHW draw-off of

| | |
|----|---------------------------------------|
| 24 | 9.9 l/min at 35 °C temperature rise. |
| 30 | 12.4 l/min at 35 °C temperature rise. |
| 35 | 14.5 l/min at 35 °C temperature rise. |

The DHW draw off rate specified above is the nominal that the boiler flow regulator will give. Due to system variations and seasonal temperature fluctuations DHW flow rates/temperature rise will vary, requiring adjustment at the draw off tap.

At low DHW draw-off rate the maximum temperature is limited to 64 °C by the modulating gas control.

The boiler features a comprehensive diagnostic system which gives detailed information on the boiler status when operating, and performance of key components to aid commissioning and fault finding.

SAFE HANDLING

This boiler may require 2 or more operatives to move it to its installation site, remove it from its packaging base and during movement into its installation location. Manoeuvring the boiler may include the use of a sack truck and involve lifting, pushing and pulling.

Caution should be exercised during these operations.

Operatives should be knowledgeable in handling techniques when performing these tasks and the following precautions should be considered:

- Grip the boiler at the base.
- Be physically capable.
- Use personal protective equipment as appropriate, e.g. gloves, safety footwear.

During all manoeuvres and handling actions, every attempt should be made to ensure the following unless unavoidable and/or the weight is light.

- Keep back straight.
- Avoid twisting at the waist.
- Avoid upper body/top heavy bending.
- Always grip with the palm of the hand.
- Use designated hand holds.
- Keep load as close to the body as possible.
- Always use assistance if required.

OPTIONAL EXTRA KITS

- **Horizontal Flue Terminal** (1000mm long)
- **Flue Extension Ducts** (1000mm long)
 - 24-up to 9m
 - 30-up to 8m
 - 35-up to 6m
- **Flue Finishing Kit**
- **90° Elbow Kit** (maximum per installation)
 - 24-up to 6 elbows
 - 30-up to 6 elbows
 - 35-up to 4 elbows
- **45° Elbow Kit** (maximum per installation)
 - 24-up to 6 elbows
 - 30-up to 6 elbows
 - 35-up to 4 elbows
- **Roof Flue Kit** (to a maximum of 7.5m)
- **Powered Vertical Flue Kit** (5m primary and 17m secondary is a typical maximum length. For alternative details refer to Powered Vertical Instructions)
- **Concentric Flue Screw Retaining Kit**
- **Weather Collar**
- **Horizontal Flue Terminal 600mm long**
- **Pre-Piping Frame Kit**
- **Stand-Off Kit**
- **Stand-Off Kit (inc. pipes)**
- **High Level Flue Outlet Kit**
- **Flue Deflector Kit**
- **Condensate Pump Kit**
- **Mechanical Timer (24 hr) Kit**
- **Electronic Timer (7 day) kit**
- **RF Mechanical Programmable Room Thermostat (24 hr) kit**
- **RF Electronic Programmable Room Thermostat (7 day) kit**
- **Weather Compensation Kit**
- **Adjustable Flue Support Bracket**
- **DHW Expansion Vessel Kit**
- **Balcony Flue Kit**
- **Security Bracket Kit**
- **Flue Support Bracket Kit**

SAFETY

Current Gas Safety (installation and use) regulations or rules in force:

The appliance is suitable only for installation in GB and IE and should be installed in accordance with the rules in force.

In GB, the installation must be carried out by a Gas Safe Registered Engineer. It must be carried out in accordance with the relevant requirements of the:

- Gas Safety (Installation and Use) Regulations
- The appropriate Building Regulations either The Building Regulations, The Building Regulations (Scotland), Building Regulations (Northern Ireland).
- The Water Fittings Regulations or Water byelaws in Scotland.
- The Current I.E.E. Wiring Regulations.

Where no specific instructions are given, reference should be made to the relevant British Standard Code of Practice.

In IE, the installation must be carried out by a Registered Gas Installer (RGI) and installed in accordance with the current edition of I.S.813 "Domestic Gas Installations", the current Building Regulations and reference should be made to the current ETCI rules for electrical installation.

Detailed recommendations are contained in the following British Standard Codes of Practice:

- BS. 5440:1** Flues (for gas appliances of rated input not exceeding 70 kW).
- BS. 5440:2** Ventilation (for gas appliances of rated input not exceeding 70 kW).
- BSEN. 12828:2003** Heating Systems in buildings: Design for water based heating systems.
- BSEN 12831:2003** Heating Systems in buildings: Method for calculation of the design heat load.
- BSEN 14336:2004** Heating Systems in buildings: Installation and commissioning of water based heating systems.
- BS. 5546** Installation of gas hot water supplies for domestic purposes (2nd Family Gases)
- BS. 6798** Installation of gas fired hot water boilers of rated input not exceeding 70 kW.
- BS. 6891** Low pressure installation pipes.

Health & Safety Document No. 635.

The Electricity at Work Regulations, 1989.

The manufacturer's notes must NOT be taken, in any way, as overriding statutory obligations.

IMPORTANT. These appliances are CE certificated for safety and performance. It is, therefore, important that no external control devices, e.g. flue dampers, economisers etc., are directly connected to these appliances unless covered by these Installation and Servicing Instructions or as otherwise recommended by **Ideal Stelrad Group** in writing. If in doubt please enquire.

Any direct connection of a control device not approved by **Ideal Stelrad Group** could invalidate the certification and the normal appliance warranty. It could also infringe the Gas Safety Regulations and the above regulations.

SAFE HANDLING OF SUBSTANCES

No asbestos, mercury or CFCs are included in any part of the boiler or its manufacture.

LOCATION OF BOILER

The boiler must be installed on a flat and vertical internal wall, capable of adequately supporting the weight of the boiler and any ancillary equipment.

The boiler may be fitted on a combustible wall and insulation between the wall and the boiler is not necessary, unless required by the local authority.

For electrical safety reasons there must be no access available from the back of the boiler.

The boiler must not be fitted outside.

Timber Framed Buildings

If the boiler is to be fitted in a timber framed building it should be fitted in accordance with the Institute of Gas Engineering document IGE/UP/7:1998.

Bathroom Installations

This appliance is rated **IP20**.

The boiler may be installed in any room or internal space, although particular attention is drawn to the requirements of the current IEE (BS.7671) Wiring Regulations and the electrical provisions of the building regulations applicable in Scotland, with respect to the installation of the boiler in a room or internal space containing a bath or shower. For IE reference should be made to the current ETCI rules for electrical installations and I.S. 813:2002.

If the appliance is to be installed in a room containing a bath or shower then, providing water jets are not going to be used for cleaning purposes (as in communal baths/showers), the appliance must be installed beyond Zone 2, as detailed in BS.7671.

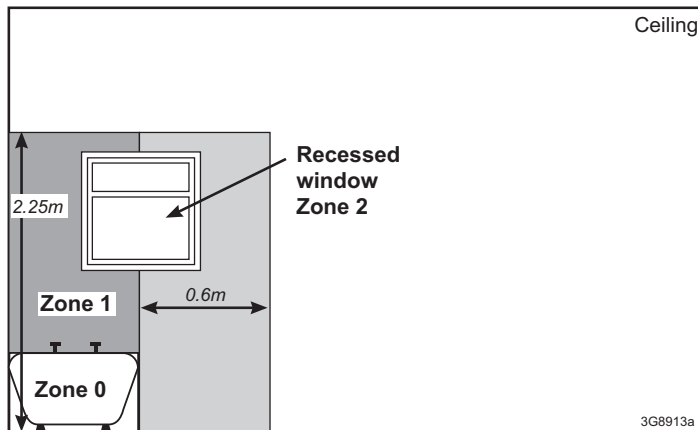

Compartment Installations

A compartment used to enclose the boiler should be designed and constructed specially for this purpose.

An existing cupboard or compartment may be used, provided that it is modified for the purpose.

In both cases, details of essential features of cupboard / compartment design, including airing cupboard installation, are to conform to the following:

- BS 6798 (No cupboard ventilation is required - see 'Air Supply' for details).
- The position selected for installation MUST allow adequate space for servicing in front of the boiler.
- For the minimum clearances required for safety and subsequent service, see the wall mounting template and Frame 1. In addition, sufficient space may be required to allow lifting access to the wall mounting plate.

GAS SUPPLY

The local gas supplier should be consulted, at the installation planning stage, in order to establish the availability of an adequate supply of gas. An existing service pipe must NOT be used without prior consultation with the local gas supplier.

The boiler MUST be installed on a gas supply with a governed meter only.

A gas meter can only be connected by the local gas supplier or by a Gas Safe Registered Engineer. In IE by a Registered Gas Installer (RGI).

An existing meter should be checked, preferably by the gas supplier, to ensure that the meter is adequate to deal with the rate of gas supply required.

It is the responsibility of the Gas Installer to size the gas installation pipework in accordance with BS6891:2005. Whilst the principle of the 1:1 gas valve ensures the Logic + range is able to deliver it's full output at inlet pressures as low as 14mb, other gas appliances in the property may not be as tolerant. When operating pressures are found to be below the minimum meter outlet of 19mb these should be checked to ensure this is adequate for correct and safe operation.

Allowing for the acceptable pressure loss of 1mb across the installation pipework, it can be assumed that a minimum permitted operating pressure of 18mb will be delivered to the inlet of the appliance. (Reference BS 6400-1 Clause 6.2 Pressure Absorption).

The external gas cock could further reduce the operating pressure when measured at its test point. The pressure drop is relative to the heat input to the boiler (kW), refer to graph below.

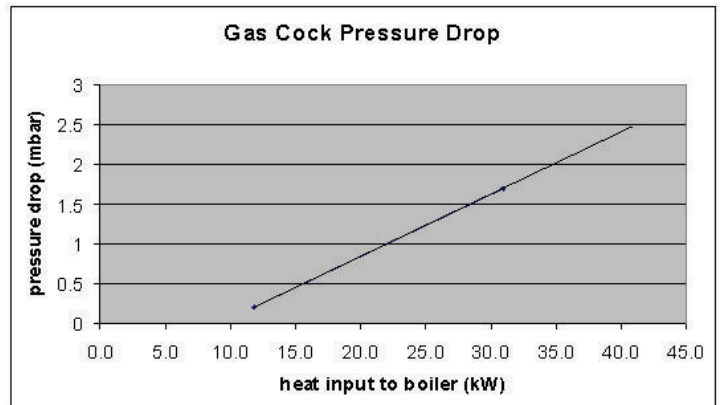

IMPORTANT.

Installation pipes must be fitted in accordance with BS.6891. In IE refer to IS.813:2002.

The complete installation MUST be tested for gas tightness and purged as described in the above code.

FLUE INSTALLATION

Plumbing will occur at the terminal so terminal positions where this could cause a nuisance should be avoided.

The flue must be installed in accordance with the recommendations of BS. 5440-1: 2008.

In IE refer to I.S. 813:2002.

The following notes are intended for general guidance:

1. The boiler MUST be installed so that the terminal is exposed to external air.
2. It is important that the position of the terminal allows the free passage of air across it at all times.

Ideal Logic + Combi - Installation and Servicing

GENERAL

3. Minimum acceptable spacing from the terminal to obstructions and ventilation openings are specified in Table 4.
4. Where the lowest part of the terminal is fitted less than 2m (6'6") above a balcony, above ground or above a flat roof to which people have access then the terminal **MUST** be protected by a purpose designed guard.
Terminal guards are available from boiler suppliers. (Ask for TFC flue guard model no. K6 - round, plastic coated). In case of difficulty contact:

Grasslin (UK) Ltd. Tel. + 44 (0) 01732 359 888
Tower House, Vale Rise Fax. + 44 (0) 01732 354 445
Tonbridge. Kent TN9 1TB www.tfc-group.co.uk

Ensure that the guard is fitted centrally.
5. The flue assembly shall be so placed or shielded as to prevent ignition or damage to any part of any building.
6. The air inlet/products outlet duct and the terminal of the boiler **MUST NOT** be closer than 25mm (1") to combustible material. Detailed recommendations on the protection of combustible material are given in BS. 5440-1:2008.

IMPORTANT. It is essential to ensure, in practice, that products of combustion discharging from the terminal cannot re-enter the building or buildings through any openings into the building such as ventilators, windows, doors, or other sources of natural air infiltration, such as forced ventilation openings etc.

If products of combustion re-entry is identified or suspected this should be immediately investigated and corrected following the guidance provided in the current Gas Industry Unsafe Situation Procedure.

Table 4 - Balanced Flue Terminal Position

| Flue Terminal Positions | Min. Spacing* |
|---|----------------------------|
| 1. Directly below, above or alongside an opening window, air vent or other ventilation opening. | 300mm (12") |
| 2. Below guttering, drain pipes or soil pipes. <i>BS5440-1 2008</i> | 25mm (1")* 75mm (3") |
| 3. Below eaves. <i>BS5440-1 2008</i> | 25mm (1")* 200mm (8") |
| 4. Below balconies or a car port roof. <i>BS5440-1 2008</i> | 25mm (1")* 200mm (8") |
| 5. From vertical drain pipes or soil pipes. <i>BS5440-1 2008</i> | 25mm (1")* 150mm (6") |
| 6. From an internal or external corner or to a boundary along side the terminal. <i>BS5440-1 2008</i> | 25mm (1")* 300mm (12") |
| 7. Above adjacent ground, roof or balcony level. | 300mm (12") |
| 8. From a surface or a boundary facing the terminal. | 600mm (24") |
| 9. From a terminal facing a terminal. | 1,200mm (48") |
| 10. From an opening in a car port (e.g. door or window) into dwelling. | 1,200mm (48") |
| 11. Vertically from a terminal on the same wall. | 1,500mm (60") |
| 12. Horizontally from a terminal on the wall. | 300mm (12") |
| Vertical Terminals | |
| 13. Above the roof pitch with roof slope of all angles. Above flat roof. | 300mm (12") 300mm (12") |
| 14. From a single wall face. From corner walls. | 300mm (12") 300mm (12") |
| 15. Below velux window | 2000mm (79") |
| 16. Above or side of velux window | 600mm (24") |

* Only one reduction down to 25mm is allowable per installation otherwise BS5440-1 2008 dimensions must be followed.

TERMINAL

The terminal assembly can be adapted to accommodate various wall thicknesses. Refer to Frame 10 .

AIR SUPPLY

It is NOT necessary to have a purpose-provided air vent in the room or internal space in which the boiler is installed. Neither is it necessary to ventilate a cupboard or compartment in which the boiler is installed, due to the low surface temperatures of the boiler casing during operation; therefore the requirements of BS 6798, Clause 12, and BS 5440:2 may be disregarded.

WATER CIRCULATION SYSTEM

IMPORTANT.

A minimum length of 1 metre of copper pipe **MUST** be fitted to both flow and return connections from the boiler before connection to any plastic piping.

The central heating system should be in accordance with BS.6798 and, in addition, for smallbore and microbore systems, BS.5449.

WATER TREATMENT - see Frame 5

BOILER CONTROL INTERLOCKS

Central heating systems controls should be installed to ensure the boiler is switched off when there is no demand for heating, in compliance with Building Regulations.

Heating systems utilising full thermostatic radiator valve control of temperature in individual rooms should also be fitted with a room thermostat controlling the temperature in a space served by radiators not fitted with such a valve.

When thermostatic radiator valves are used, the space heating temperature control over a living / dining area or hallway having a heating requirement of at least 10% of the minimum boiler heat output should be achieved using a room thermostat, whilst other rooms are individually controlled by thermostatic radiator valves. However, if the system employs thermostatic radiator valves on all radiators, or two port valves, then a bypass circuit must be fitted with an automatic bypass valve to ensure a flow of water should all valves be in the closed position.

ELECTRICAL SUPPLY

WARNING.

This appliance must be earthed.

Wiring external to the appliance **MUST** be in accordance with the current I.E.E. (BS.7671) Wiring Regulations and any local regulations which apply. For IE reference should be made to the current ETCI rules for electrical installations.

The mains supply to the boiler and system wiring centre shall be through one common fused double pole isolator and for new heating systems, and where practical replacement installations, the isolator shall be situated adjacent to the appliance.

CONDENSATE DRAIN

Refer to Frames 22, 23 & 46

A condensate drain is provided on the boiler. This drain must be connected to a drainage point on site. All pipework and fittings in the condensate drainage system **MUST** be made of plastic - *no other materials may be used.*

IMPORTANT.

Any external runs must be in accordance with BS 6798.

The drain outlet on the boiler is sized for standard 21.5mm (3/4") overflow pipe. It is a universal fitting to allow use of different brands of pipework.

GENERAL

1 BOILER DIMENSIONS, SERVICES & CLEARANCES

all dimensions in mm

The boiler connections are made on the boiler connection tails. Refer to Frames 29-32.

The following minimum clearances must be maintained for operation and servicing.

Additional space will be required for installation, depending upon site conditions.

Side and Rear Flue

a. Provided that the flue hole is cut accurately, e.g. with a core drill, the flue can be installed from inside the building where wall thicknesses do not exceed 600mm (24"). Where the

space into which the boiler is going to be installed is less than the length of flue required the flue must be fitted from the outside.

Installation from inside ONLY

b. If a core boring tool is to be used inside the building the space in which the boiler is to be installed must be at least wide enough to accommodate the tool.

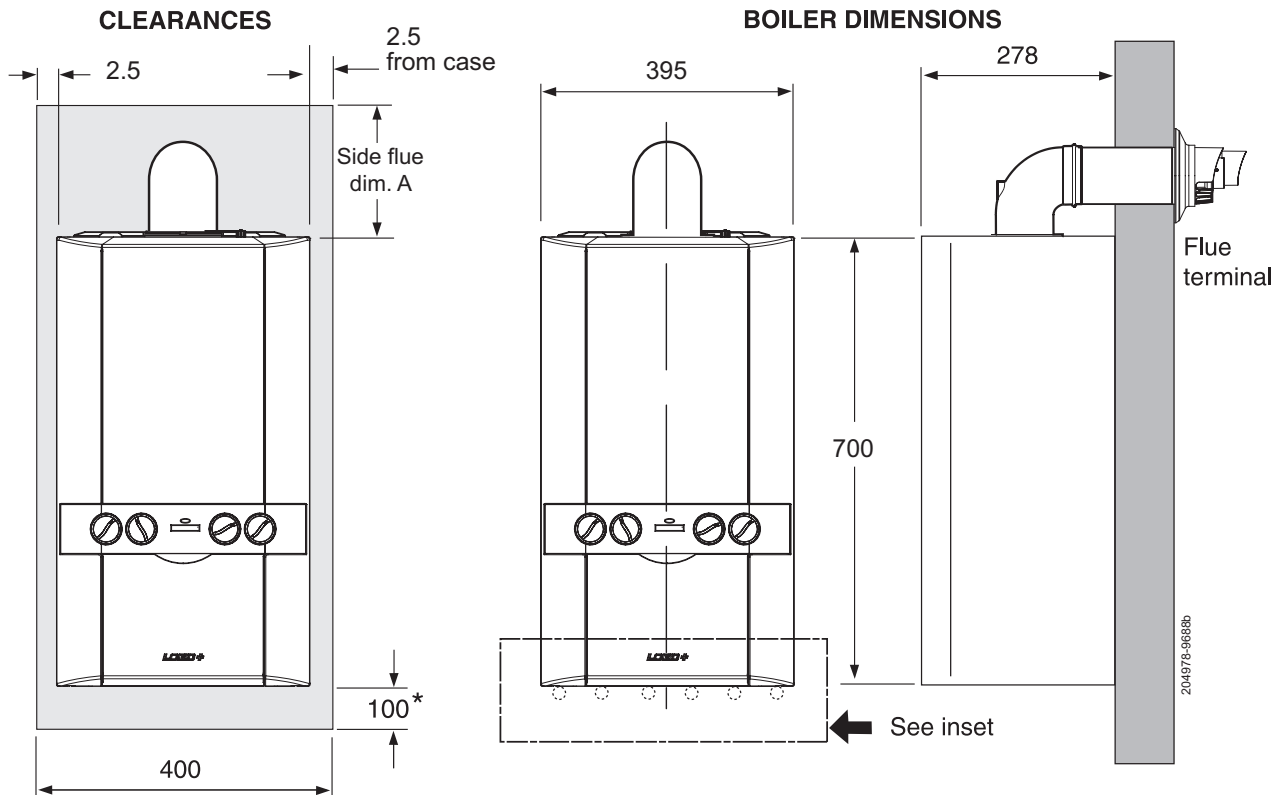

Inset: Water Connections and Gas Connection

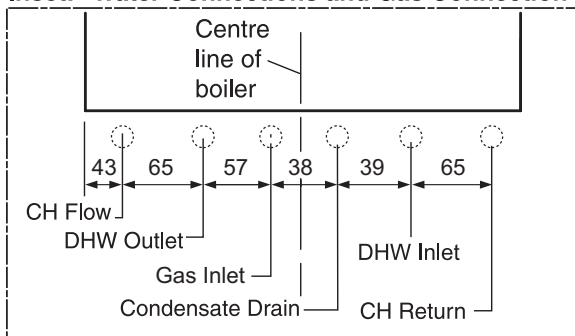

Front clearance

The minimum front clearance when built in to a cupboard is 5mm from the cupboard door but 450mm overall clearance is still required, with the cupboard door open, to allow for servicing.

* Bottom clearance

Bottom clearance after installation can be reduced to 5mm. This must be obtained with an easily removable panel, to enable the consumer to view the system pressure gauge, and to provide the 100mm clearance required for servicing.

SIDE FLUE ONLY

| Horizontal length of flue from CL of boiler to outside wall | | | Top clearance required (MIN.) Dim. A |
|---|-------|-------|--------------------------------------|
| 24 | 30 | 35 | |
| 0.5 m | 0.5 m | 0.5 m | 165 mm |
| 1.0 m | 1.0 m | 1.0 m | 170 mm |
| 1.5 m | 1.5 m | 1.5 m | 185 mm |
| 2.0 m | 2.0 m | 2.0 m | 200 mm |
| 2.5 m | 2.5 m | 2.5 m | 210 mm |
| 3.0 m | 3.0 m | 3.0 m | 225 mm |
| 3.5 m | 3.5 m | 3.5 m | 250 mm |
| 4.0 m | 4.0 m | 4.0 m | 260 mm |
| 4.5 m | 4.5 m | 4.5 m | 265 mm |
| 5.0 m | 5.0 m | 5.0 m | 275 mm |
| 5.5 m | 5.5 m | 5.5 m | 290 mm |
| 6.0 m | 6.0 m | 6.0 m | 300 mm |
| 6.5 m | 6.5 m | N/A | 320 mm |
| 7.0 m | 7.0 m | N/A | 330 mm |
| 7.5 m | 7.5 m | N/A | 345 mm |
| 8.0 m | 8.0 m | N/A | 360 mm |
| 8.5 m | N/A | N/A | 370 mm |
| 9.0 m | N/A | N/A | 385 mm |

REAR FLUE ONLY

MIN. Top clearance required = 165 mm

GENERAL

2 SYSTEM REQUIREMENTS - Central Heating

Notes

- a. The method of filling, refilling, topping up or flushing sealed primary hot water circuits from the mains via a temporary hose connection is only allowed if acceptable to the local water authority.
- b. Antifreeze fluid, corrosion and scale inhibitor fluids suitable for use with boilers having aluminium heat exchangers may be used in the central heating system.

General

1. The installation must comply with all relevant national and local regulations.
2. The installation should be designed to work with flow temperatures of up to 86 °C.
3. All components of the system must be suitable for a working pressure of 3 bar and temperature of 110 °C. Extra care should be taken in making all connections so that the risk of leakage is minimised.

The following components are incorporated within the appliance:

- a. Circulating pump.
 - b. Safety valve, with a non-adjustable preset lift pressure of 3 bar.
 - c. Pressure gauge, covering a range of 0 to 4 bar.
 - d. An 8-litre expansion vessel, with an initial charge pressure of 0.75 bar.
4. **'Make-up' Water.** Provision must be made for replacing water loss from the system, either :

- a. From a manually filled 'make-up' vessel with a readily visible water level. The vessel should be mounted at least 150mm above the highest point of the system and be connected through a non-return valve to the system, fitted at least 150mm below the 'make-up' vessel on the return side of the radiators. **or**
- b. Where access to a 'make-up' vessel would be difficult, by pre-pressurisation of the system.

The maximum cold water capacity of the system should not exceed 143 litres, if not pressurized. However, if the system is to be pressurized, the efficiency of the expansion vessel will be reduced and a larger vessel (or smaller system volume) may be necessary. If the capacity of the vessel is not considered sufficient for this, or for any other reason, an additional vessel **MUST** be installed on the return to the boiler.

Guidance on vessel sizing is given in Table above.

| | | | |
|---|-----|---|-------|
| Safety valve setting | bar | 3.0 | |
| Vessel charge pressure | bar | 0.5 to 0.75 | |
| System pre-charge pressure | bar | None | 1.0 |
| System volume (litres) | | Expansion vessel volume (litres) | |
| | 25 | 1.6 | 1.8 |
| | 50 | 3.1 | 3.7 |
| | 75 | 4.7 | 5.5 |
| | 100 | 6.3 | 7.4 |
| | 125 | 7.8 | 9.2 |
| | 150 | 9.4 | 11.0 |
| | 175 | 10.9 | 12.9 |
| | 190 | 11.9 | 14.0 |
| | 200 | 12.5 | 14.7 |
| | 250 | 15.6 | 18.4 |
| | 300 | 18.8 | 22.1 |
| For other system volumes multiply by the factor across | | 0.063 | 0.074 |

Water Flow Rate and Pressure Loss

| | | |
|---------------------------|---------------------|------------------|
| Max CH Output | kW (Btu/h) | 24.2 (82,600) |
| Water flow rate | l/min (gal/min) | 17.3 (3.8) |
| Temperature Differential | °C (°F) | 20 (36) |
| Head available for system | m.w.g. (ft.w.g.) | 3.4 (11.1) |

5. Filling

The system may be filled by the following method:

Where the mains pressure is excessive a pressure reducing valve must be used to facilitate filling.

- a. Thoroughly flush out the whole system with cold water.
- b. Fill and vent the system until the pressure gauge registers 1bar and examine for leaks. Refer to Frame 29 for filling detail.
- c. Check the operation of the safety valve by raising the water pressure until the valve lifts. This should occur within 0.3bar of the preset lift pressure.
- d. Release water from the system until the minimum system design pressure is reached; 1.0 bar if the system is to be pre-pressurised.

continued

GENERAL

3 SYSTEM REQUIREMENTS - (continued)

DOMESTIC HOT WATER

1. The domestic hot water service must be in accordance with BS 5546 and BS 6700.
2. Refer to Table 1 for minimum and maximum working pressures. In areas of low mains water pressures the domestic hot water regulator may be removed from the DHW flow turbine cartridge. Refer to Frame 67. The boiler will require the flow rate to be set to obtain a temperature rise of 35°C at the tap furthest from the boiler.
3. The boilers are suitable for connection to most types of washing machine and dishwasher appliances.
4. When connecting to suitable showers, ensure that:
 - a. The cold inlet to the boiler is fitted with an approved anti-vacuum or syphon non-return valve.
 - b. Hot and cold water supplies to the shower are of equal pressure.

5. Hard Water Areas

Where the water hardness exceeds 200mg/litre, it is recommended that a proprietary scale reducing device is fitted into the boiler cold supply within the requirements of the local water company.

IMPORTANT. Provision must be made to accommodate the expansion of DHW contained within the appliance. If the DHW inlet contains a back flow prevention device or non-return valve, e.g. a water meter, then a mini expansion vessel should be fitted between the device and the boiler in the cold inlet pipe.

Note. DHW Expansion Vessel kit available from Ideal.

4 SYSTEM BALANCING

The boiler does not normally need a bypass but at least some radiators on the heating circuit, of load of at least 10% of the minimum boiler output, must be provided with twin lockshield valves so that this minimum heating load is always available. See note regarding thermostatic radiator valves on page 9.

Note. *Systems incorporating zone valves which could completely cut off the flow through the system must also include a bypass.*

BALANCING

1. Set the programmer to ON.

Close the manual or thermostatic valves on all radiators, leaving the twin lockshield valves (on the radiators referred to above) in the OPEN position.

Turn up the room thermostat and adjust the lockshield valve to give an uninterrupted flow through the radiator.

These valves should now be left as set.
2. Open all manual or thermostatic radiator valves and adjust the lockshield valves on the remaining radiators, to give around 20°C temperature drop at each radiator.
3. Adjust the room thermostat and programmer to NORMAL settings.

5 WATER TREATMENT

CENTRAL HEATING

The Logic + Combi range of boilers have an ALUMINIUM alloy heat exchanger.

IMPORTANT.

The application of any other treatment to this product may render the guarantee of Ideal Stelrad Group Invalid.

Ideal Stelrad Group recommend Water Treatment in accordance with the Benchmark Guidance Notes on Water Treatment in Central Heating Systems.

If water treatment is used **Ideal Stelrad Group** recommend only the use of Scalemaster Gold 100, FERNOX, MBI or SENTINEL X100 inhibitors and associated water treatment products, which must be used in accordance with the manufacturers' instructions.

Notes.

1. *It is most important that the correct concentration of the water treatment products is maintained in accordance with the manufacturers' instructions.*
2. *If the boiler is installed in an existing system any unsuitable additives MUST be removed by thorough cleansing. BS 7593:2006 details the steps necessary to clean a domestic heating system.*
3. *In hard water areas, treatment to prevent lime scale may be necessary - however the use of artificially softened water is NOT permitted.*
4. *Under no circumstances should the boiler be fired before the system has been thoroughly flushed.*

DOMESTIC HOT WATER

In hard water areas where mains water can exceed 200ppm Total Hardness (as defined by BS 7593:2006 Table 2) a scale reducing device should be fitted into the boiler cold supply within the requirements of the local water company. The use of artificially softened water, however, is not permitted.

Ideal Stelrad Group recommend the use of Fernox Quantomat, Sentinel Combiguard and Calmag CalPhos I scale reducing devices, together with Scalemaster Inline Scale Inhibitor branded Ideal, which must be used in accordance with the manufacturers' instructions.

For further information contact:

Fernox Manufacturing Co. Ltd
Cookson Electronics
Forsyth Road, Sheerwater, Woking, Surrey GU21 5RZ
+44 (0) 1799 521133

Sentinel Performance Solutions
The Heath Business & Technical Park
Runcorn, Cheshire WA7 4QX
Tel: 0800 389 4670

Scalemaster Water Treatment Products
Emerald Way, Stone
Staffordshire ST15 0SR
Tel: +44 (0) 1785 811636

Calmag Ltd.
Unit 4-6, Crown Works, Bradford Road,
Sandbeds, Keighley, West Yorkshire BD20 5LN
Tel: +44 (0) 1535 210 320

INSTALLATION

6 BOILER ASSEMBLY - Exploded View

Note that item numbers are linked to the spares list

- | | | | |
|------------------------------|-------------------------------|--------------------------------------|--------------------------------|
| 104 CH Return Valve | 120 Flow Group Manifold | 219 Sump Clean Out Cover | 309 Thermistor No flow |
| 105 CH Flow Valve | 121 Plate Heat Exchanger | 223 Flue Manifold | 313 Ignition Lead |
| 106 DHW Inlet & Outlet | 127 Flow Sensor Hall Effect | 224 Flue Manifold Top | 314 Control Box Lens |
| 107 Filling Loop | 128 Flow Turbine Cartridge | 227 Clamp Retaining Flue Turret | 324 Control Box Lid |
| 108 Pump Head | 131 Water Pressure Transducer | 228 Hose Condensate Internal | 325 Control Box Front |
| 110 Air Vent Pump | 135 Pressure Gauge | 229 Siphon Trap | 326 Programmer Insert |
| 111 Divertor Valve Head | 203 Gas Cock | 230 Siphon Trap Cap & Seal | 401 Heat Engine |
| 112 Divertor Valve Cartridge | 204 Pipe - Gas Inlet | 231 Condensate Outlet Connection | 503 Wall Mounting Bracket |
| 113 Pressure Relief Valve | 205 Gas Valve | 233 Flue Sensing Nipple | 504 Front Panel |
| 114 Pipe - PRV Outlet | 206 Pipe - Gas Injector | 301 Ctrl Box Fixings Hings & Spring | 505 Fascia |
| 115 Pipe - Flow | 211 Injector Assembly | 302 Primary PCB* | 506 Bracket - Gas Valve |
| 116 Pipe - Return | 214 Venturi | 303 CUI Board | 507 Bracket - Expansion Vessel |
| 117 Pipe - Expansion Vessel | 215 Fan | 304 Control Thermistor (Flow/Return) | 512 Drop Down Door |
| 118 Expansion Vessel | 217 Burner | 306 Electrode Ignition | |
| 119 Return Group Manifold | 218 Gasket - Burner | 307 Electrode Detection | |
| | | 308 Ignitor Unit | |

* Note that production boiler PCBs are factory pre-set to operate for boiler range and output, but when ordering Primary PCB as a spare, an additional Boiler Chip Card (BCC) MUST also be purchased for your specific boiler range and output.

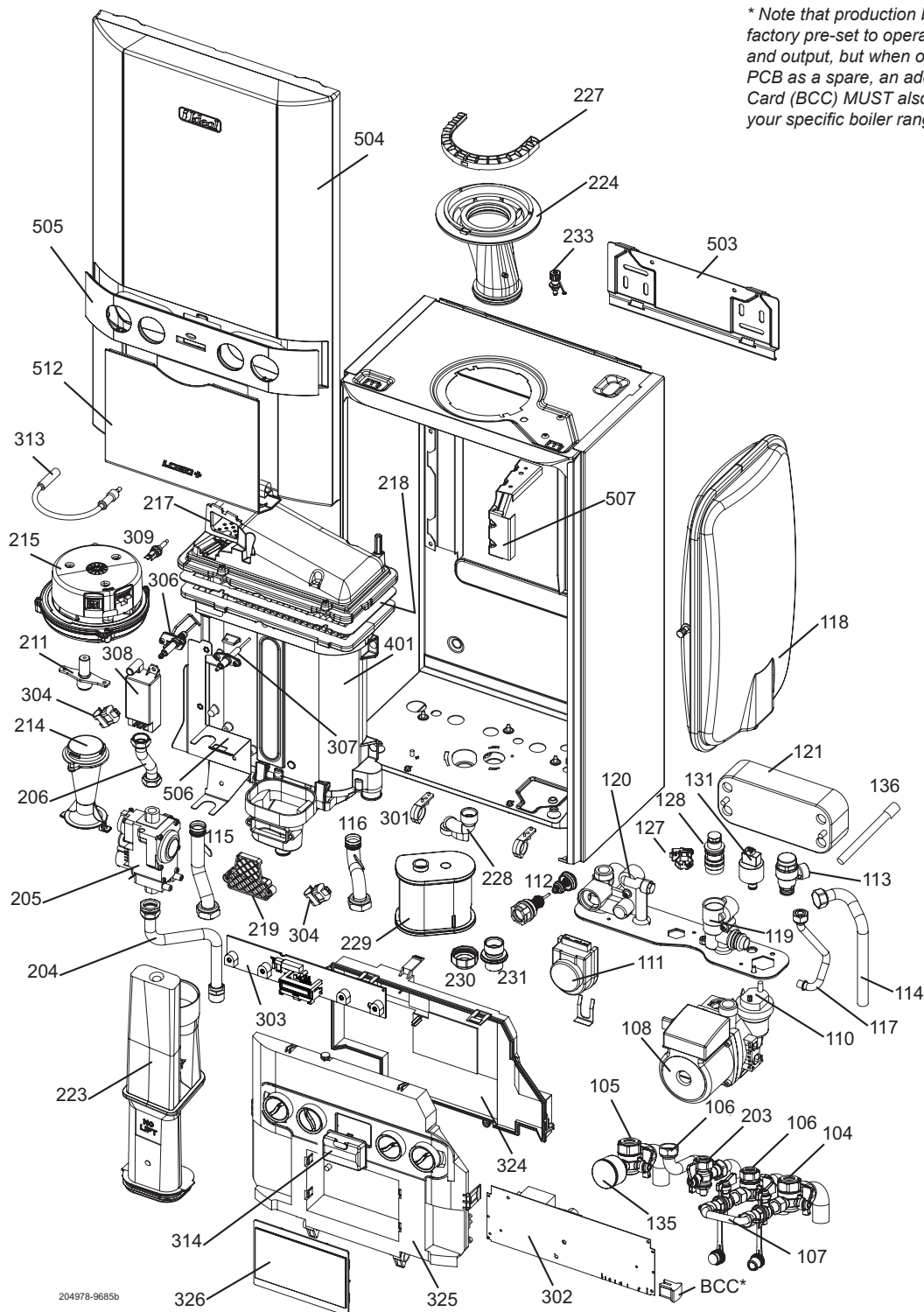

204978-9685b

INSTALLATION

INSTALLATION

7 UNPACKING

The boiler is supplied fully assembled in one Pack A, together with a telescopic flue assembly for lengths up to 595mm, rear or side flue outlet, in Pack B.

Unpack and check the contents.

Pack A Contents

- A Boiler
- B Hardware Pack Box
- C Wall Mounting Plate
- D These Installation Instructions
- E Wall Mounting Template (located on internal protective packaging)
- F Turret Clamp
- G Safety Valve Drain Pipe
- H Boiler Guarantee & Registration Pack

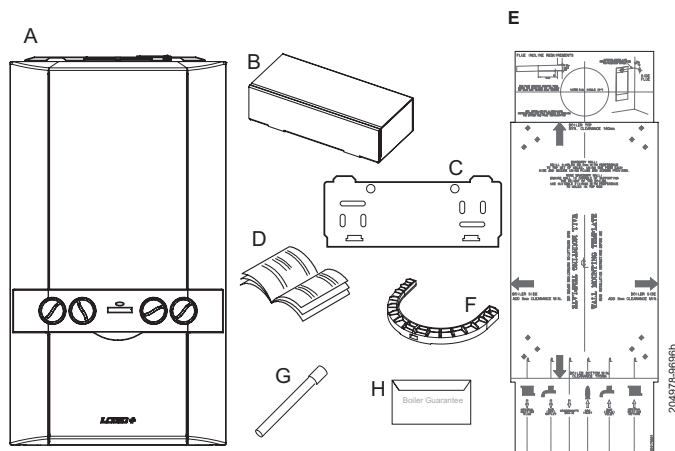

HARDWARE PACK CONTENTS

Gas Valve Pack

1. Pipe - Gas Inlet
2. Washer - Gas (blue)
3. Gas Cock

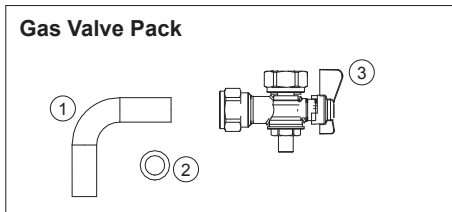

Filling Loop Pack

1. 3/8" Top Hat Washer (x2)
2. Plastic Chain (x2)
3. 3/8" Blanking Cap (x1)
4. Valve - Dbl Check Filling Loop (x1)
5. 3/8" Fibre Washer (x2)
6. 3/8" Blanking Cap Extended (x1)
7. Valve Filling Loop (x1)
8. Filling Loop with 3/8" Nuts (x1)

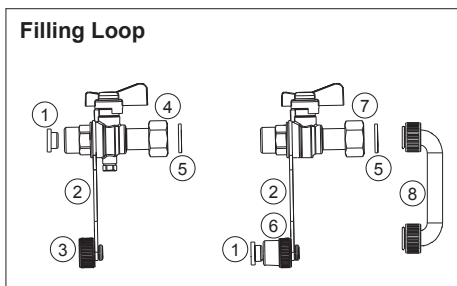

Return Valve Pack

1. Pipe CH Return
2. Washer CH
3. Valve Return

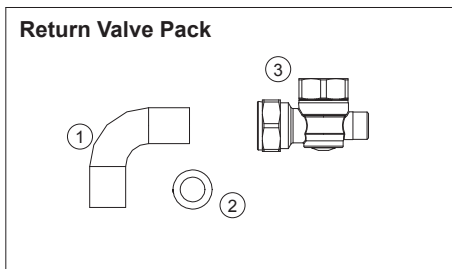

DHW Pack

1. Pipe DHW Outlet
2. Valve - Return DHW
3. Washer DHW (x2)
4. Pipe DHW Inlet
5. Nut 1/2"

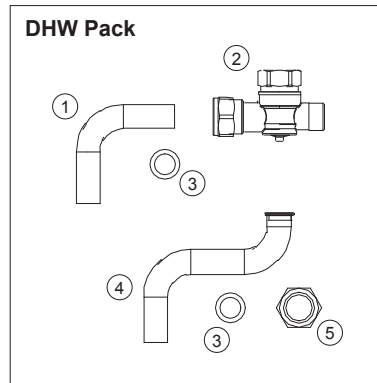

Accessory Pack

1. Screw (x2)
2. Wallplug (x2)

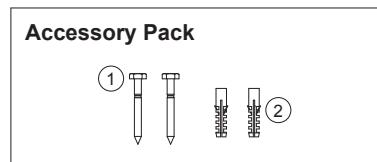

Flow Valve Pack

1. Pipe CH Flow
2. Washer CH
3. Valve Flow (with gauge)

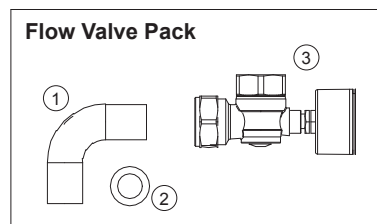

204978-9687b

continued

8 UNPACKING CONT'D

Pack B Contents Telescopic (supplied as standard)

- A Telescopic flue terminal
- B Flue turret
- C Rubber Terminal Wall SEal
- D Screw
- E Sealing tape

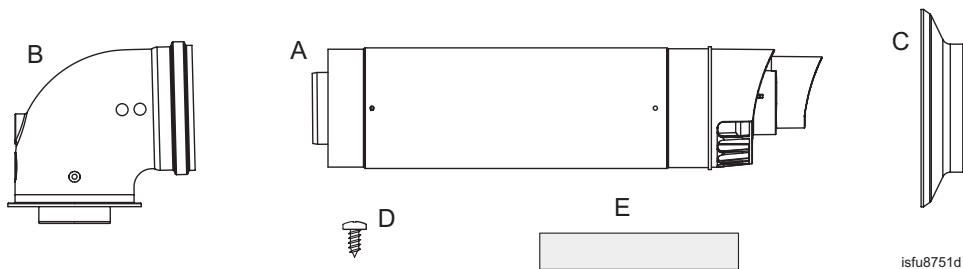

Pack B Contents Non-Telescopic (optional)

- A Flue terminal
- B Flue turret
- C Rubber Terminal Wall Seal
- D Cutting Aid

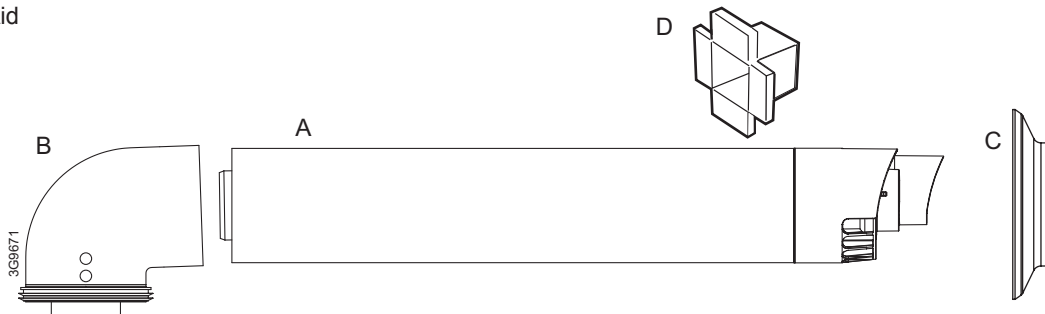

9 FRONT PANEL REMOVAL

1. Loosen the 2 screws retaining the front panel.
2. Pull the two spring clips downwards to disengage.
3. Pull the front panel forward and upwards to remove.

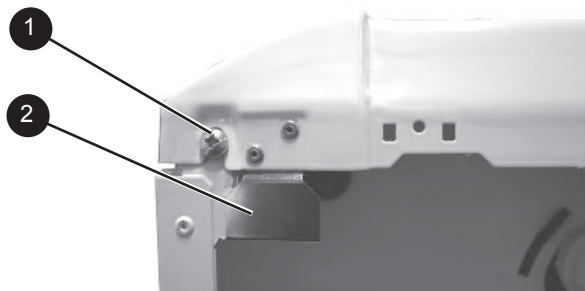

INSTALLATION

10 DETERMINING THE FLUE LENGTH AND FLUE PACKS REQUIRED

IMPORTANT. The boiler MUST be installed in a vertical position

Dimension X - Wall thickness.
Dimension L - Wall thickness plus boiler spacing.
Dimension S - Optional stand-off frame depth 45mm.

FLUE KITS

Pack B - telescopic supplied as standard

Pack B - optional non-telescopic

Pack D - optional extension kit for side flue or rear flue outlet.

Concentric Flue Screw Retaining Kit - optional kit for mechanical fixing of flue joints.

Finishing Kit - Supplied as an optional extra.

Refer to 'Flue Extension Ducts'

Note. MAXIMUM FLUE LENGTHS:

24 - 9M (HORIZONTAL FLUE)

30 - 8M (HORIZONTAL FLUE)

35 - 6M (HORIZONTAL FLUE)

24, 30 35 - 7.5M (ROOF FLUE)

24, 30 & 35 - 5M PRIMARY AND 17M SECONDARY IS A TYPICAL MAX.

FLUE LENGTH. (For alternative details refer to Powered Vertical Instructions)

90° ELBOW KIT 60/100 (EQUIVALENT FLUE LENGTH RESISTANCE = 1M)

45° ELBOW KIT 60/100 (EQUIVALENT FLUE LENGTH RESISTANCE = 0.6M)

MINIMUM HORIZONTAL FLUE LENGTHS - TELESCOPIC TERMINAL = 350MM

(Centre Line of turret to outside of wall terminal) - ONE PIECE TERMINAL = 285MM

REAR FLUE

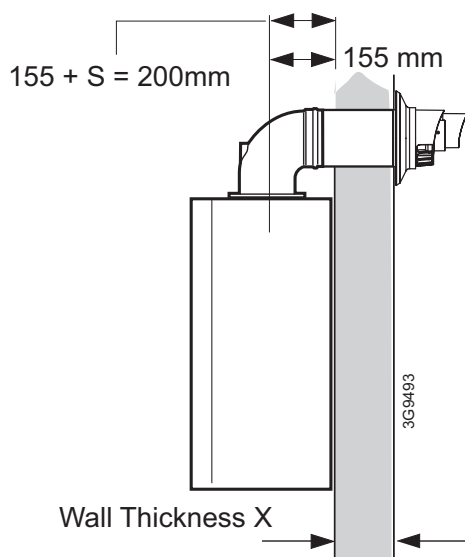

SIDE FLUE

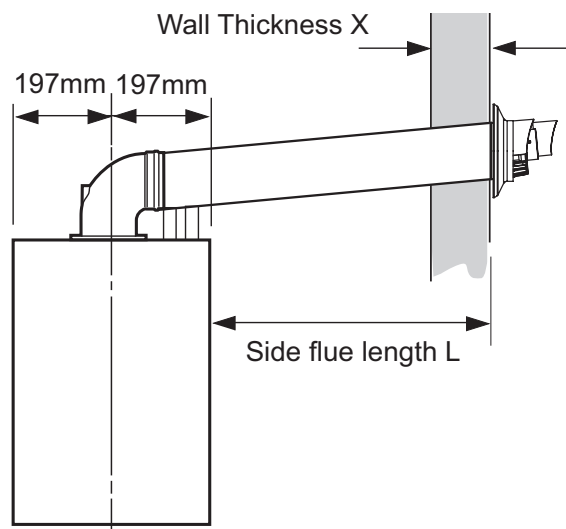

continued

INSTALLATION

11 DETERMINING THE FLUE LENGTH AND FLUE PACKS REQUIRED CONT'D

Notes.

1. It is recommended that a support bracket is fitted for every 1 metre of extension pipe used and a bracket should be used at every joint, to ensure pipes are held at the correct angle. If a slip joint coupling is to be used then a bracket should be used to secure the collar.
2. When extension 'D' packs are used the flue duct MUST be inclined at 1.5 degrees to the horizontal to allow condensate to drain back into the boiler and out through the condensate drain.
3. If the B pack, or telescopic B pack only are used, they may be mounted horizontally. The 1.5 degrees is taken care of by the inclination of the flue within the air pipe.
4. Only use water as a lubricant during assembly.

TELESCOPIC FLUE

| Total Flue length dimension (measuring from CL of turret to outside wall) | | Flue | |
|--|----------------------|----------------------|--------------|
| Rear flue dim. X+155 | Side flue dim. L+197 | Extra packs required | Boiler Size |
| Up to 575 mm | Up to 575 mm | none | 24,30 & 35 |
| Up to 1525 mm | Up to 1525 mm | Pack D - 1 off | 24,30 & 35 |
| Up to 2475 mm | Up to 2475 mm | Pack D - 2 off | 24,30 & 35 |
| Up to 3425 mm | Up to 3425 mm | Pack D - 3 off | 24, 30 & 35 |
| Up to 4375 mm | Up to 4375 mm | Pack D - 4 off | 24, 30 & 35 |
| Up to 5325 mm | Up to 5325 mm | Pack D - 5 off | 24, 30 & 35 |
| Up to 6275 mm | Up to 6275 mm | Pack D - 6 off | 24, 30 & 35* |
| Up to 7225 mm | Up to 7225 mm | Pack D - 7 off | 24 & 30 |
| Up to 8175 mm | Up to 8175 mm | Pack D - 8 off | 24 & 30** |
| Up to 9000 mm | Up to 9000 mm | Pack D - 9 off | 24 |

*Logic Combi 35 is capable of 6m flue only
** Logic Combi 30 is capable of 8m flue only

NON - TELESCOPIC FLUE

| Total Flue length dimension (measuring from CL of turret to outside wall) | | Flue | |
|--|----------------------|----------------------|--------------|
| Rear flue dim. X+155 | Side flue dim. L+197 | Extra packs required | Boiler Size |
| Up to 640 mm | Up to 640 mm | none | 24,30 & 35 |
| Up to 1590 mm | Up to 1590 mm | Pack D - 1 off | 24,30 & 35 |
| Up to 2540 mm | Up to 2540 mm | Pack D - 2 off | 24,30 & 35 |
| Up to 3490 mm | Up to 3490 mm | Pack D - 3 off | 24, 30 & 35 |
| Up to 4440 mm | Up to 4440 mm | Pack D - 4 off | 24, 30 & 35 |
| Up to 5390 mm | Up to 5390 mm | Pack D - 5 off | 24, 30 & 35 |
| Up to 6340 mm | Up to 6340 mm | Pack D - 6 off | 24, 30 & 35* |
| Up to 7290 mm | Up to 7290 mm | Pack D - 7 off | 24 & 30 |
| Up to 8240 mm | Up to 8240 mm | Pack D - 8 off | 24 & 30** |
| Up to 9000 mm | Up to 9000 mm | Pack D - 9 off | 24 |

*Logic Combi 35 is capable of 6m flue only
** Logic Combi 30 is capable of 8m flue only

12 FLUE ASSEMBLY - Exploded View

An optional flue duct extension kit is required for wall thicknesses greater than :

Side 378mm
Rear 420mm

LEGEND

1. Duct assembly.
2. Flue turret.
3. Turret clamp.

Telescopic B Pack shown

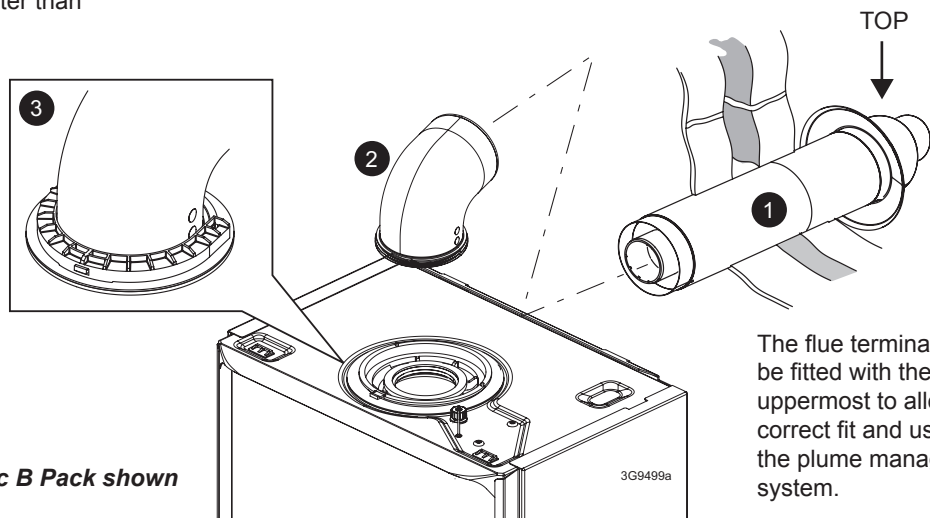

The flue terminal MUST be fitted with the 'TOP' uppermost to allow the correct fit and use of the plume management system.

INSTALLATION

13 WALL MOUNTING TEMPLATE

The wall mounting template is located on the internal protective packaging.

Note.

The template shows the positions of the fixing holes and the rear flue hole centre for standard installation. Care MUST be taken to ensure the correct holes are drilled.

1. Tape template into the selected position. Ensure squareness by hanging a plumbline as shown.
2. If fitting a side flue extend the flue centre line onto the side wall and measure in 155mm for standard installation.
3. Mark onto the wall the following:
 - a. The wall mounting plate screw positions (choose one from each group).
 - b. The position of the flue duct hole (see diagram below).

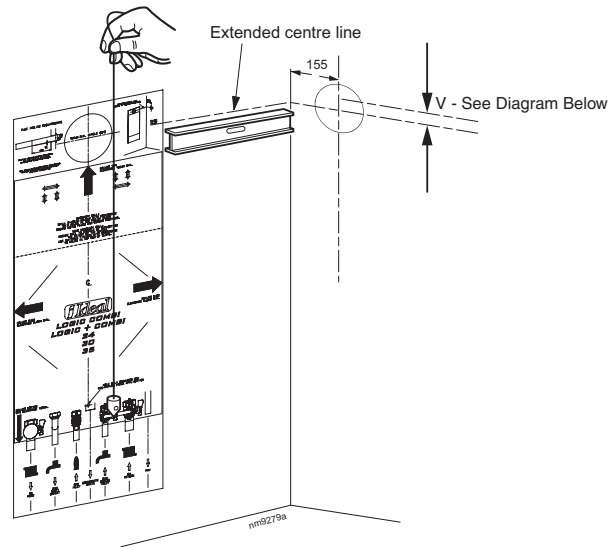

Note. Mark the centre of the hole as well as the circumference.

4. Remove the template from the wall.

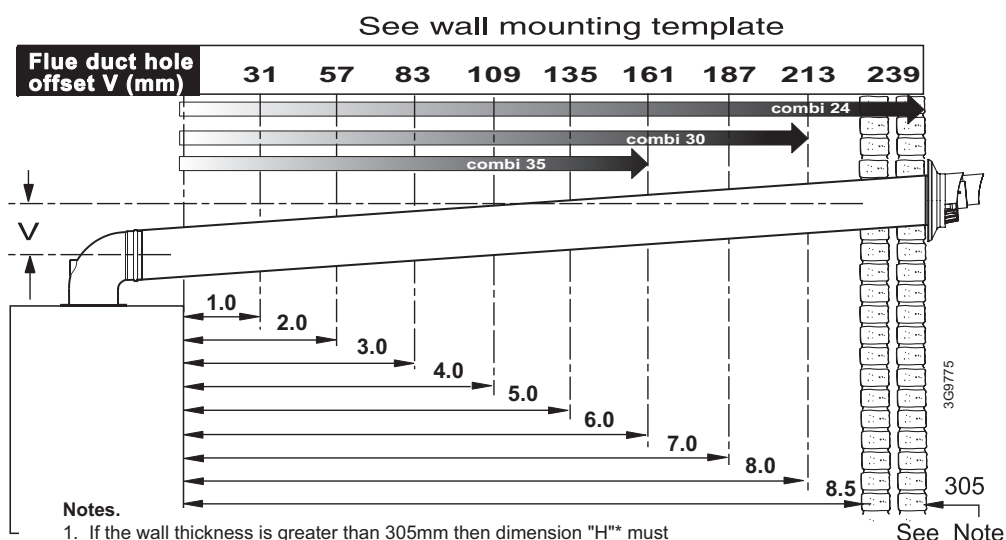

Notes.

1. If the wall thickness is greater than 305mm then dimension "H" must be reduced by the same amount and the offset may be adjusted accordingly.
2. For flue lengths greater than 600mm the flue must be inclined by 26mm per 1000mm flue length.

* "H" = Distance in metres from side of the boiler to the side wall

FLUE OUTLET

14 PREPARING THE WALL

IMPORTANT.

Ensure that, during the cutting operation, masonry falling outside of the building does not cause damage or personal injury.

1. Cut the flue hole (preferably with a 5" core boring tool), ensuring that the hole is square to the wall. Both wall faces immediately around the cut hole should be flat.
2. Drill 2 holes with a 7.5mm / 8mm masonry drill and insert the plastic plugs, provided, for the wall mounting plate.
3. Locate 2 No.14 x 50mm screws in the wall mounting plate (one at each side, in any of the 3 holes provided at each side) and screw home.

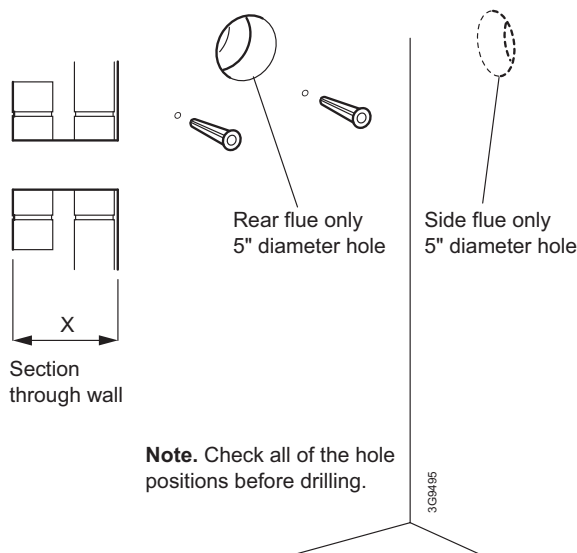

INSTALLATION

15 TERMINAL WALL SEAL ASSEMBLY / POSITIONING

Prior to fitting the flue, the rubber terminal wall seal provided in the flue pack **MUST** be fitted to the flue terminal as shown below in Figure 1.

Once the flue is installed it is **IMPORTANT** that the rubber terminal wall seal is pressed against the outside wall to create an adequate seal between the flue and wall as shown in Figure 2.

FIGURE 1

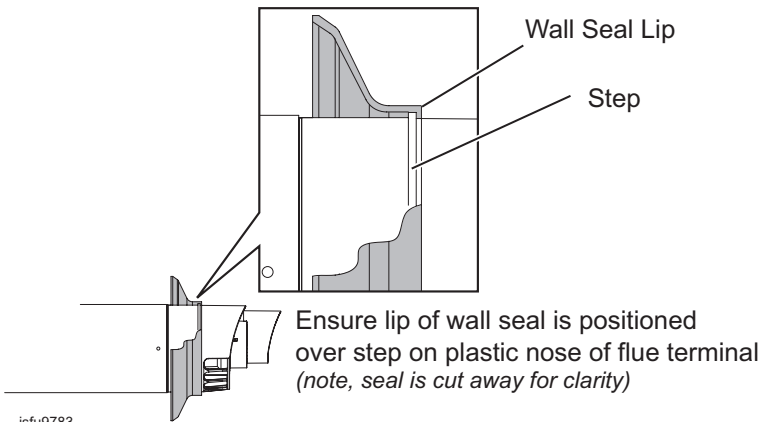
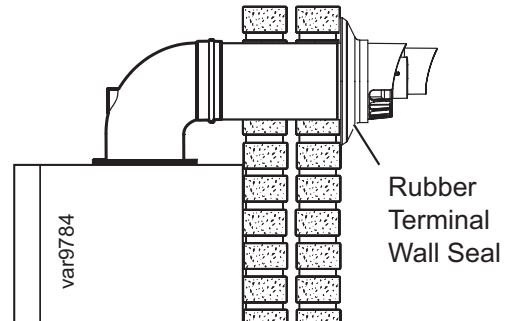

FIGURE 2



16A SETTING THE FLUE - REAR

TELESCOPIC FLUE - Wall thickness of 195mm to 420mm

Notes.

- a. If using the extension ducts go to Frame 17.
- b. For shorter flue requirements use non telescopic B Pack.
- c. If the stand-off frame is used it is essential to add 45mm to 'X' the measured wall thickness when marking the flue (this will allow for the fitted frame).

1. Measure and note wall thickness X. Refer to Frame 10.
2. Add 75mm to dimension X and set telescopic flue length as indicated in drawing.
3. Using a 3.5mm drill bit, drill one hole in outer air duct taking care not to pierce plastic inner flue.
4. Fix to length using self tappers provided.
5. Seal outer air duct using the tape provided.

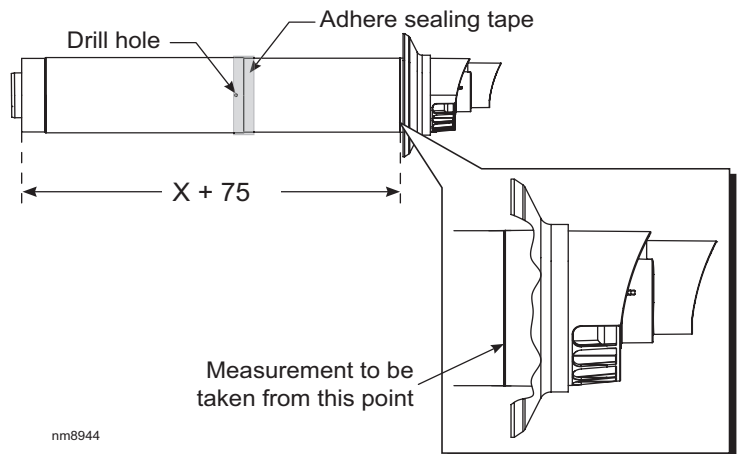

NON TELESCOPIC FLUE - Wall thickness of 115mm to 485mm

Notes.

- a. If using the extension ducts go to Frame 17.
- b. If the stand-off frame is used it is essential to add 45mm to 'X' the measured wall thickness when marking the flue (this will allow for the fitted frame).

1. Measure and note wall thickness X. Refer to Frame 10.
2. Add 90mm to dimension X and, measuring from the ring, cut the outer tube only.
3. To ensure the tube is cut square, mark the flue all the way around.
4. Cut the inner tube to a length 20mm longer to aid engagement, using the cutting aid provided.

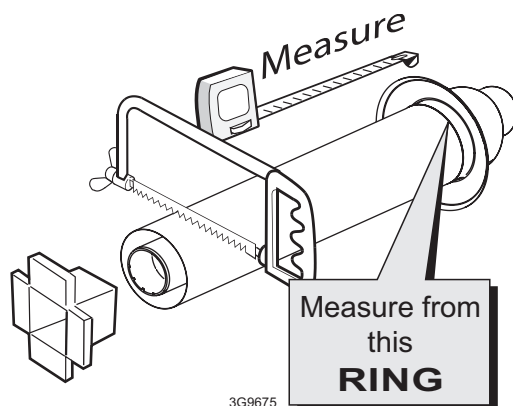

INSTALLATION

16B SETTING THE FLUE - SIDE

TELESCOPIC FLUE - Wall thickness of 150mm to 375mm

Notes.

- a. If using the extension ducts go to Frame 17.
- b. For shorter flue requirements use non telescopic B Pack.

1. Measure and note wall thickness X. Refer to Frame 10.
2. Measure distance from side of boiler to inside of wall and add to wall thickness $X=L$. Refer to Frame 10.
3. Add 115mm to dimension L and set telescopic flue length as indicated in drawing.
4. Using a 3.5mm drill bit, drill one hole in outer air duct taking care not to pierce plastic inner flue.
5. Fix to length using self tappers provided.
6. Seal outer air duct using the tape provided.

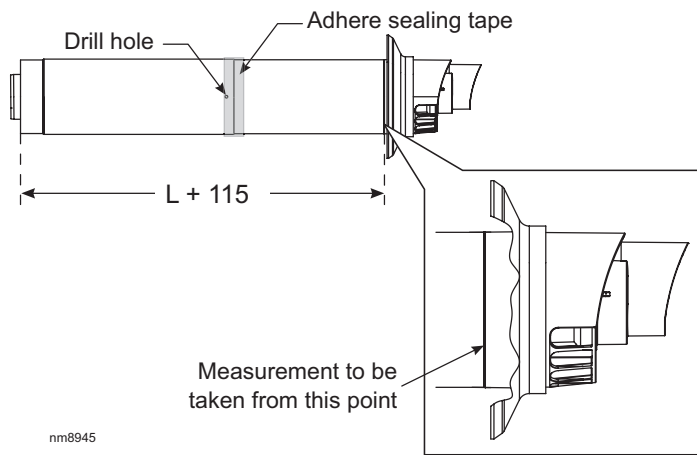

NON TELESCOPIC FLUE - Wall thickness of 115mm to 440mm

Notes.

If using the extension ducts go to Frame 17.

1. Measure and note side flue length L. Refer to Frame 10.
2. Add 125mm to dimension L and, measuring from the ring, cut the outer tube only.
3. To ensure the tube is cut square, mark the flue all the way around.
4. Cut the inner tube to a length 20mm longer to aid engagement, using the cutting aid provided

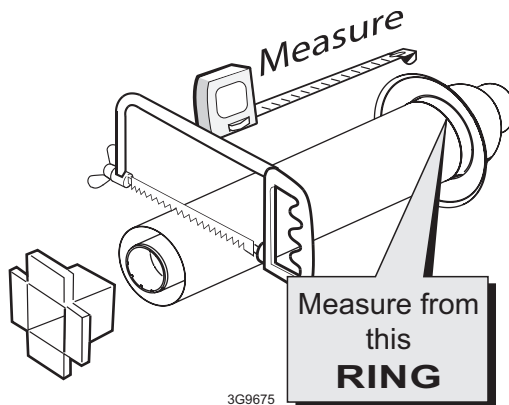

17 FLUE EXTENSION DUCTS - For total flue lengths greater than 575mm

Pack D Flue extension duct kit contents

Extension duct & clamp
1.0m (39") long

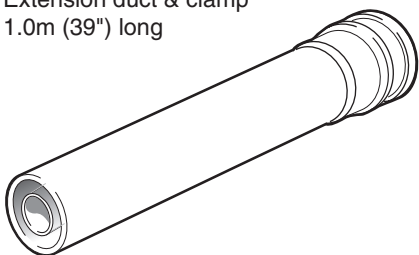

nm8732

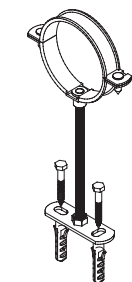

Flue duct support

Flue support cutting aid
(shown folded up)

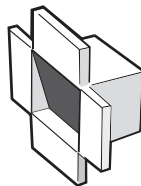

No. 10 x2" wood screw - 4 off

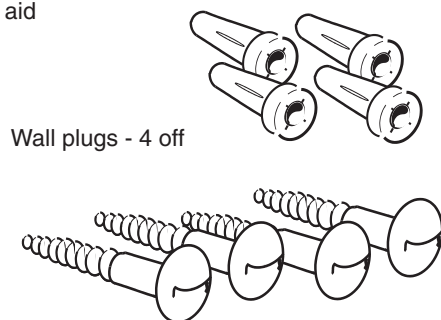

Wall plugs - 4 off

FLUE OUTLET

INSTALLATION

18 FLUE EXTENSION DUCTS - continued

Use a maximum of 9m extended flue ONLY (24)

Use a maximum of 8m extended flue ONLY (30)

Use a maximum of 6m extended flue ONLY (35)

General arrangement

1. A **maximum** number of extension ducts are possible for each boiler output with one suitably cut.
 - 9 extension ducts for 24
 - 8 extension ducts for 30
 - 6 extension ducts for 35Refer to Frame 11 for lengths
2. Flue extensions of greater length than 1m should be supported with the bracket provided, suitably adjusted. Refer to Frames 17 and 26.
3. Only use water as a lubricant during assembly. Do not use mineral based oils.

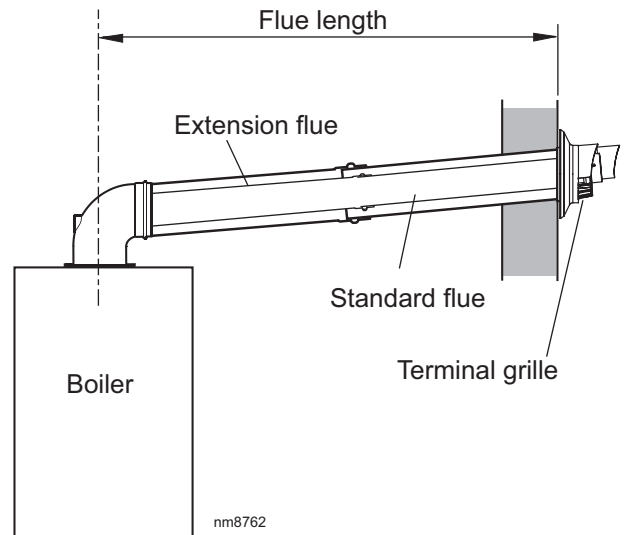

19 FITTING THE KIT

If the telescopic flue terminal is used it is not always necessary to cut an extension pack.

1. Measure the total flue length 'L' from the centre of the boiler outlet to the outside wall.
2. Subtract 65mm from this dimension.
3. Subtract 950mm for each 'D' pack to be used.
4. If the remainder Y is 300mm - 500mm this can be taken up by the adjustment in the telescopic flue.
5. If the remainder Y is 500mm - 950mm it will be necessary to use a further 'D' pack cut to 400mm.
6. If the remainder Y is less than 300mm, shorten the previous 'D' pack to suit required length and adjust the telescopic terminal.
7. Measure and mark the length on the flue, to ensure a square cut mark the flue all the way around and cut to length.

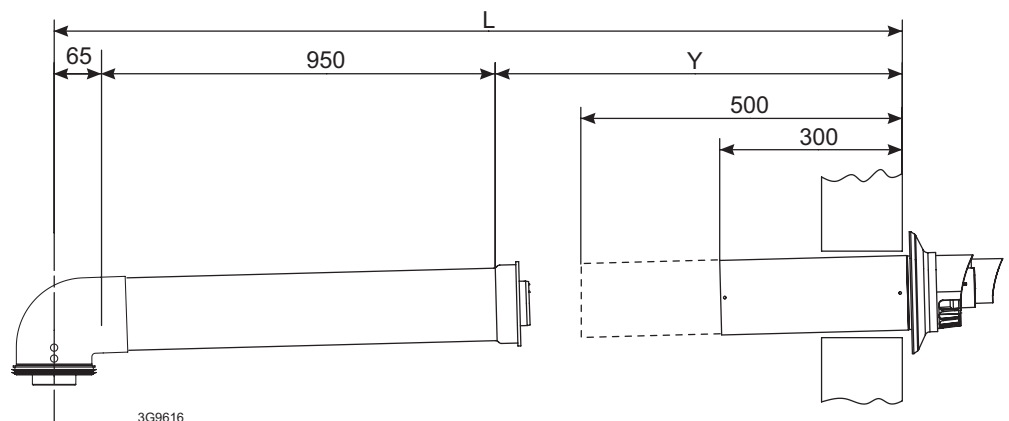

INSTALLATION

20 FITTING THE WALL MOUNTING PLATE

Screw the wall mounting plate to the wall using 2 wall plugs (previously fitted) with the 2 screws provided.

Choose one of the 2 sets of slots in left and right bank. Ensuring that at least one of the screws is fitted into a top slot.

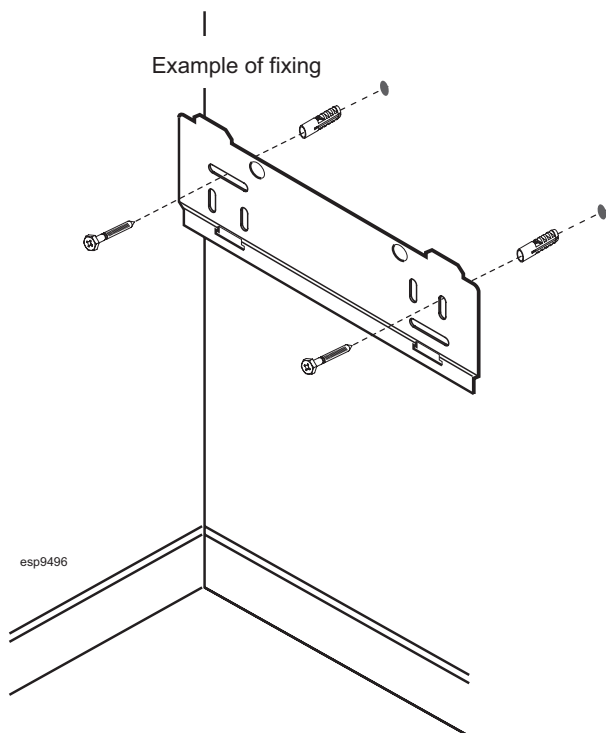

21 MOUNTING THE BOILER

1. Ensure the plastic plugs are removed from both the CH and DHW connections before mounting the boiler.
2. Lift the boiler onto the wall mounting plate (refer to the Introduction section for safe handling advice), locating it over the two tabs.

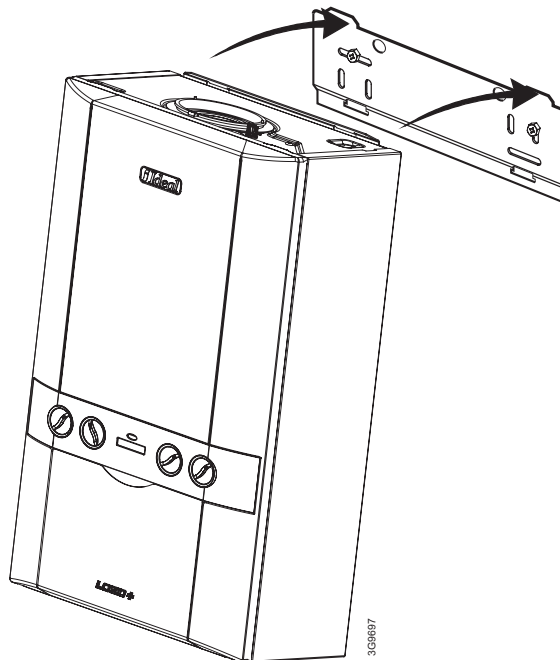

22 CONDENSATE DRAIN

Ensure that the siphon is full of water before commissioning the boiler. Refer to Frame 24.

The routing of the drain must be made to allow a minimum fall of 1 in 20 away from the boiler, throughout its length.

The drainage pipework must be arranged so that obstruction (e.g. through freezing) of external drainage pipe does not give rise to spillage within the dwelling.

IMPORTANT.

All pipework and fittings in the condensate drain system must be made of plastic. No other materials may be used.

The drain outlet on the boiler is standard 21.5mm overflow pipe and is suitable for either push fit or solvent weld applications. This size must not be reduced in any part of its length.

The boiler includes as standard, a 75mm condensate trap. The condensate trap also includes a siphon to reduce the possibility of freezing in the drain outlet.

If external condensate pipe run is greater than 3m then pipe should be 32mm nominal diameter. Consideration should be given to insulating external condensate pipe runs.

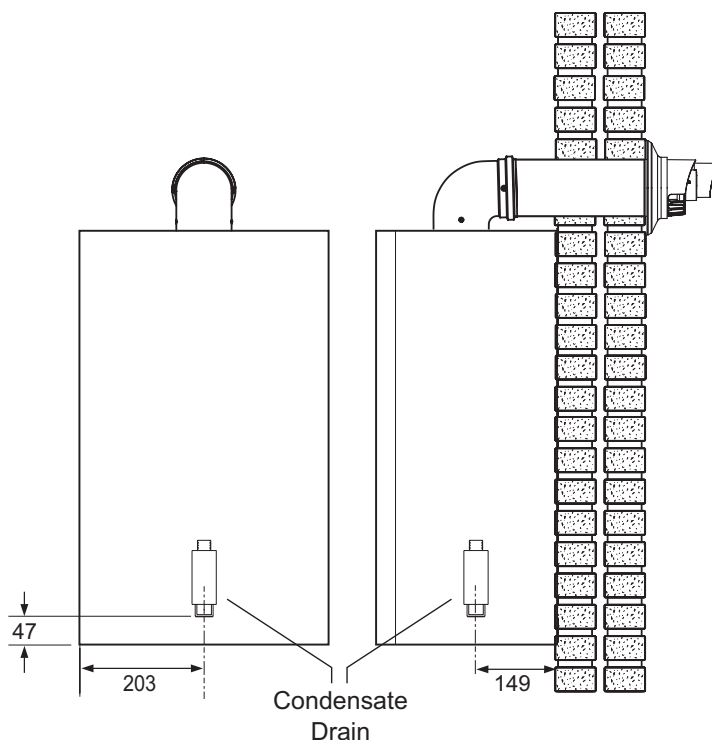

INSTALLATION

23 CONDENSATE PIPE TERMINATION CONFIGURATIONS

Notes: ALL EXTERNAL PIPE RUNS MUST BE IN ACCORDANCE WITH BS 6798

1. INTERNAL TO SINK WASTE UPSTREAM OF SINK WASTE TRAP

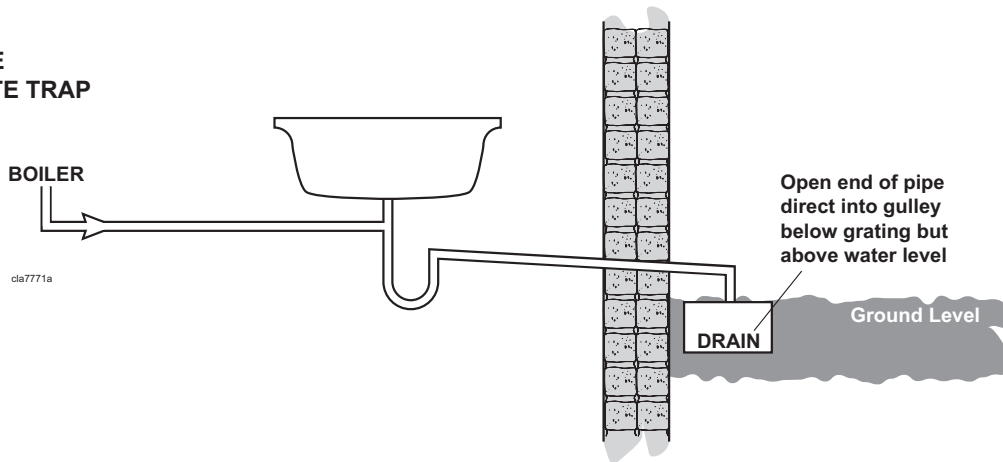

2. INTERNAL CONNECTION TO SOIL AND VENT STACK

* Make connection to SVP using a solvent welded saddle

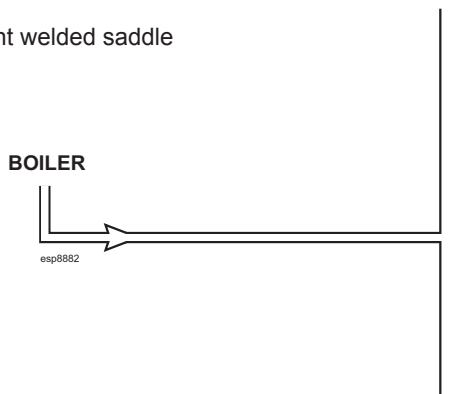

3. TERMINATION TO SOAK AWAY

4. TERMINATION TO DRAIN / GULLY

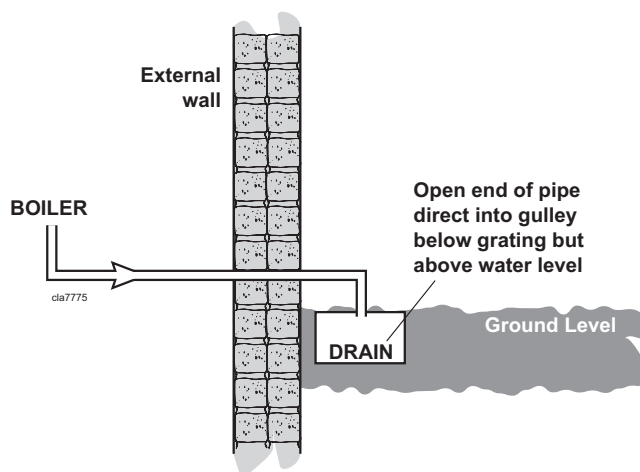
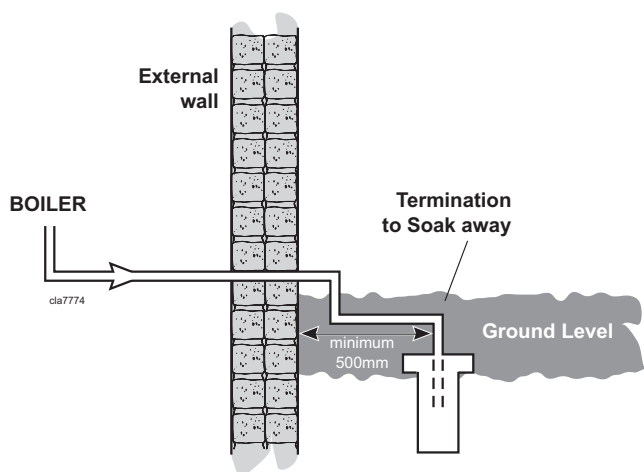

INSTALLATION

24 CONNECTING THE FLUE TO THE BOILER

Notes.

- Before fitting the flue turret fill the condensate trap within the boiler by pouring a cupful of water into the flue outlet (shown below). Take care to ensure that the water is only poured into the flue outlet, and does not spill into the boiler casing.
- During assembly check that flue seals do not become dislodged.

NOTE. SIDE FLUE

Select the orientation before inserting turret into boiler flue manifold.

DO NOT twist the turret once inserted.

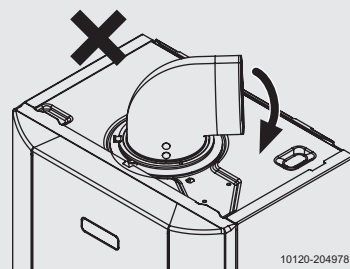

1. Ensure front panel is removed. Refer to Frame 9.
2. Locate the flue into the turret.
3. Insert the flue assembly through the prepared hole in the wall. Push through and pull back to seal against outside wall face.
4. Ensure rubber flue seal is present & fully engaged into plastic top flue manifold then locate the flue turret into the flue manifold and secure by applying downward pressure.
5. Engage the clamp in its slide mechanism and push it horizontally backwards.
6. Locate BOTH plastic pegs BEFORE the front retaining clip is fully located.

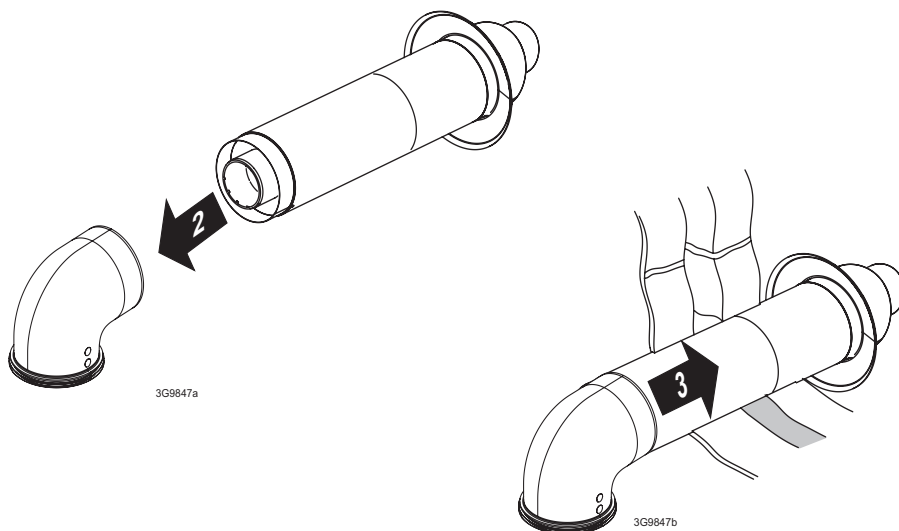

Note - Flues over 1 metre long

It is recommended that a support bracket is fitted for every 1 metre of extension pipe used and a bracket should be used at every joint, to ensure pipes are held at the correct angle.

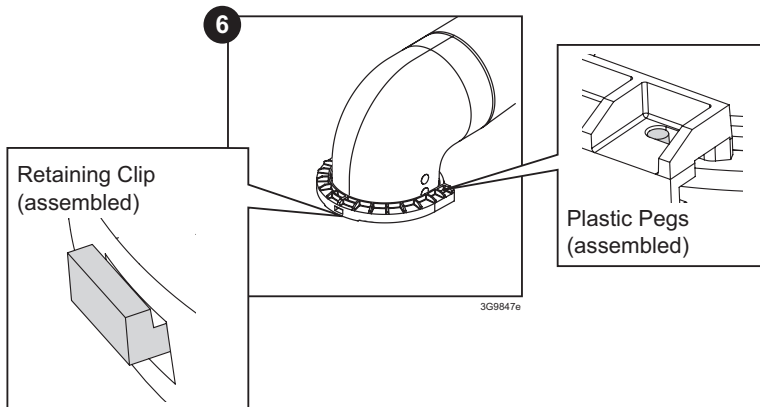
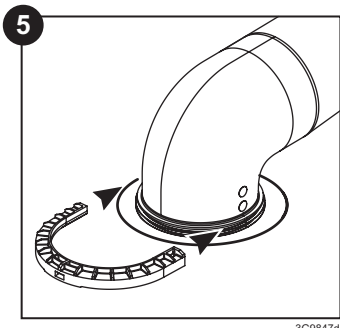
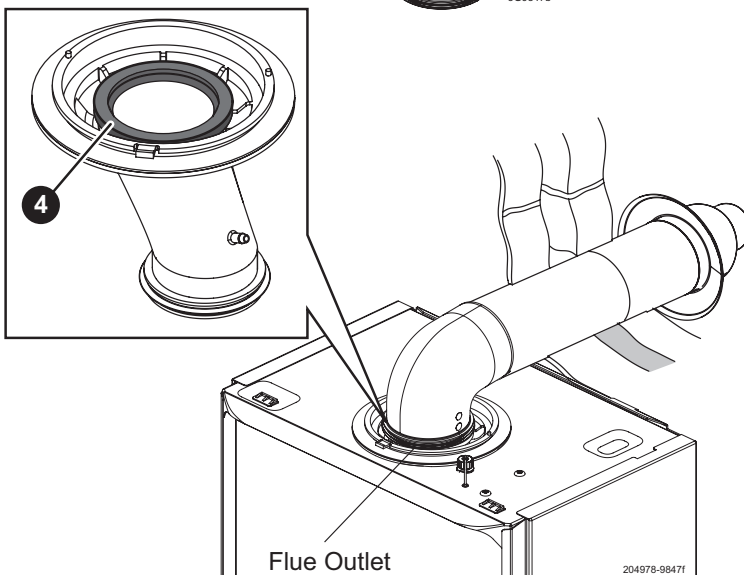

INSTALLATION

25 FITTING THE OPTIONAL ROOF FLUE KIT (Flat or Pitched)

Note.

A flat or pitched roof flashing plate (not supplied) is required before proceeding with the installation of this kit.

This kit is suitable for both flat and pitched roof terminations, using a concentric flue to run vertically from the top of the boiler and terminating above roof level.

Connection to the top of the boiler is made using a separately supplied vertical connector.

WEATHER PROOFING

Where the flue passes through the roof line an adequate seal must be made. This is achieved by using either:

- Flat roof weather collar
- or
- Universal weather collar.

ACCESSORIES

Flue Duct Extension Kits are available for flue lengths extending beyond 1m. These packs contain 1m extension ducts and may be cut to the desired length.

If the offset vertical option is used an elbow Kit is required. For a full accessories list refer to page 7 , Optional Extras and Frame 26, Flue Arrangement.

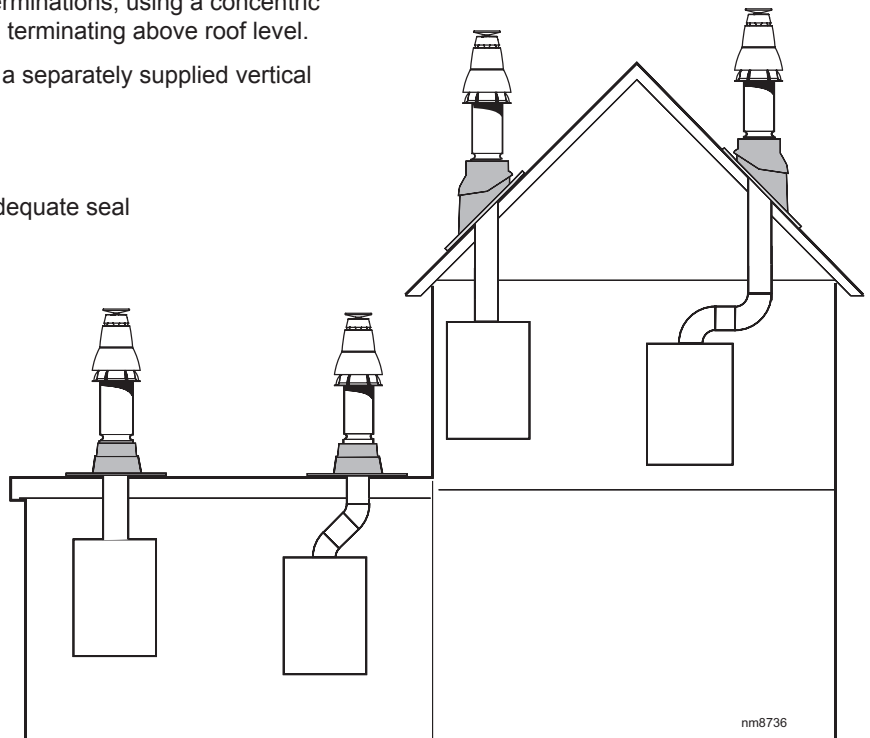

26 ROOF FLUE KIT CONTENTS / OPTIONS

Flue Terminal
UIN 203132

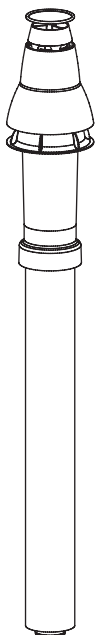

Flue Seal Collar - Flat Roof
UIN 152259

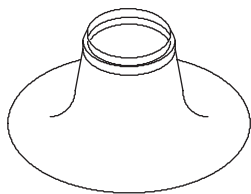

Vertical connector
UIN 204645

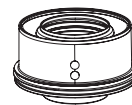

90° elbow
UIN 203130



45° elbow
UIN 203131

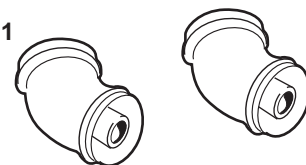

Flue Seal Collar - Tile Roof
UIN 152258

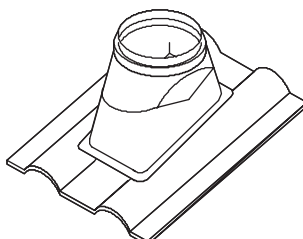

Roof Flue Extension Duct
UIN 203129

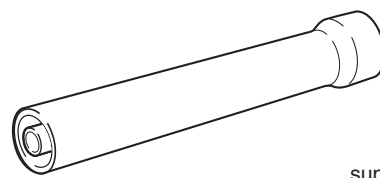

Flue duct support



Flue duct support

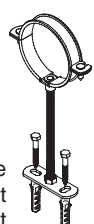

3CG9626a

INSTALLATION

27 FLUE TERMINAL POSITION

The terminal should be positioned so that products of combustion can safely disperse at all times.

Plumbing may occur at the termination so, where possible, terminal positions where this could cause a nuisance should be avoided.

Minimum dimensions are shown below

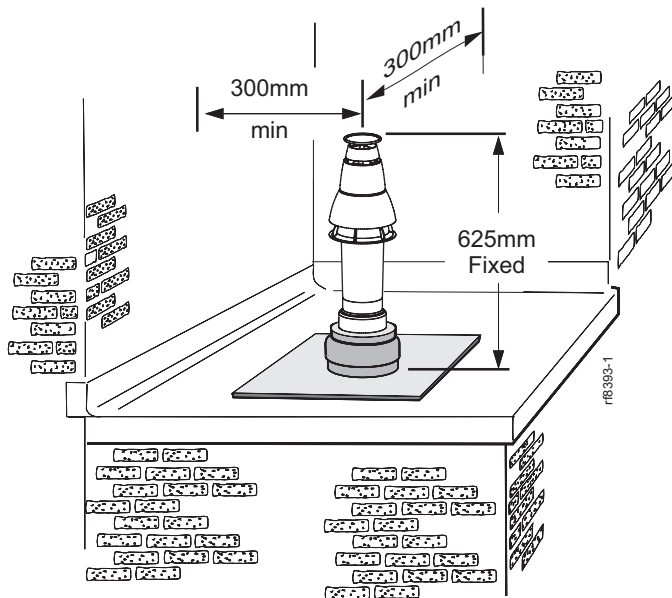

Flat roof - with structure

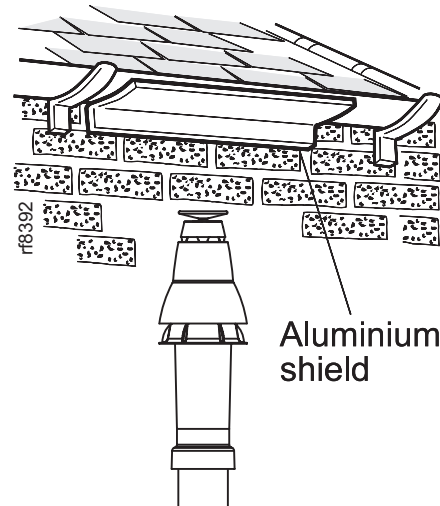

Aluminium shield

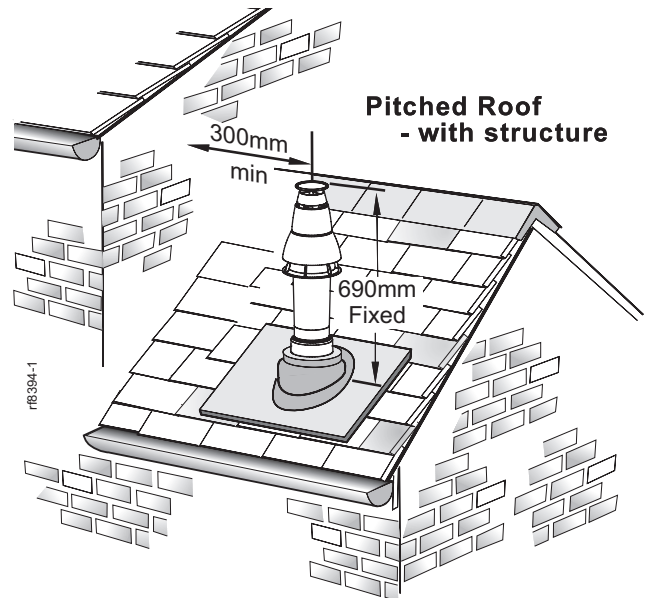

Pitched Roof - with structure

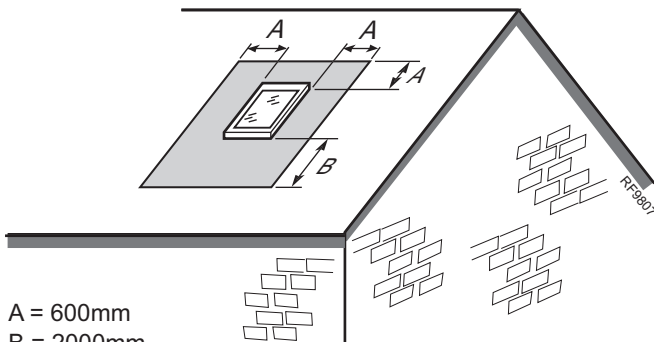

A = 600mm
B = 2000mm

The flue terminal shall not penetrate the shaded area of the roof

| Terminal Position | Minimum Dimension |
|---|-------------------|
| Directly below an opening, air brick, windows, etc. | 300 mm |
| Below plastic / painted gutters | 300 mm |
| Painted surface | 300 mm |
| Below eaves or balcony | 500 mm |
| Below velux windows | 2000mm |
| Above or side of velux windows | 600mm |

Note.

The equivalent flue length resistance of the elbow kits are:

90° elbow kit = 1m

45° elbow kit = 0.6m

FLUE OUTLET

28 ASSEMBLING THE ROOF FLUE KIT

Determine the correct height that the flue should terminate above the roof. If after calculating or measuring the overall flue height from the top of the boiler, it is necessary to cut both pipes of assembly A, then ensure they are cut equally leaving the inner flue tube longer than the outer air tube as supplied.

Ensure the cut pipe ends are free from any burrs.

1. Position the roof flashing plate (supplied separately) over the hole cut in the roof and insert flue terminal from the roof end.

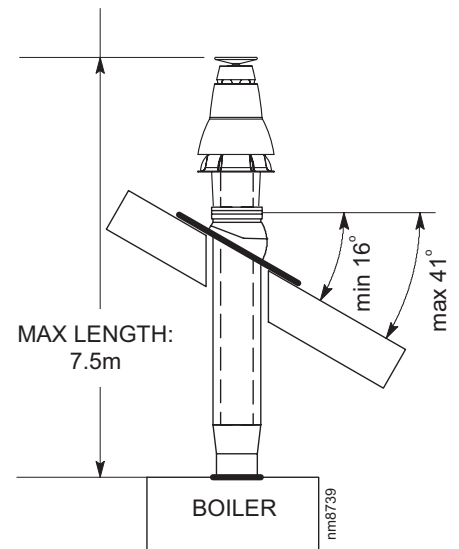
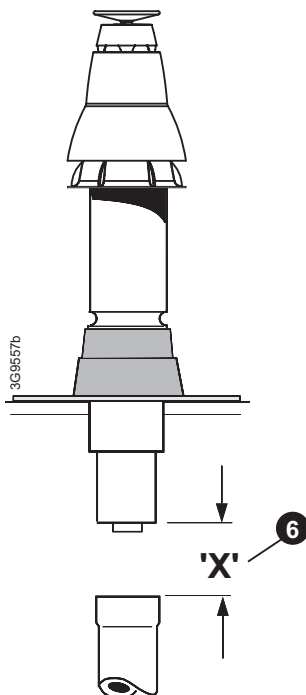
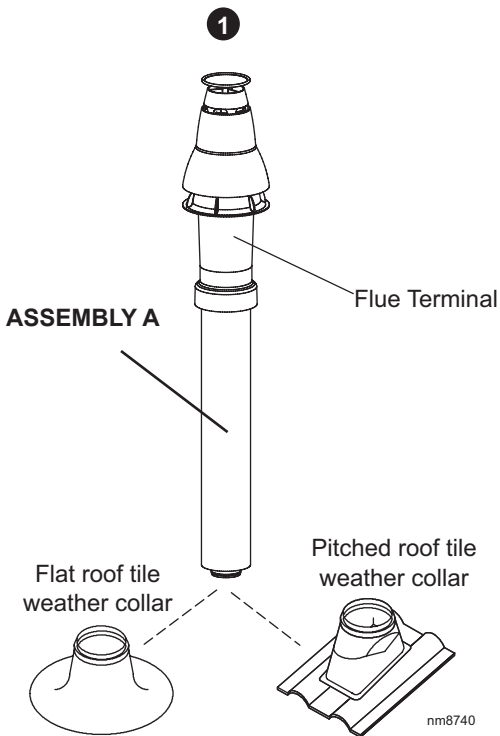

2. Fit the vertical connector (supplied separately) in accordance with the instructions provided with the vertical connector kit.
3. Secure the vertical connector by applying downward pressure on the connector.
4. Engage the clamp in its slide mechanism and push it horizontally backwards, locating on BOTH plastic pegs BEFORE the front retaining clip is fully located (as shown in Frame 24).
5. "Push" fit extension duct (if required (supplied separately)) into vertical connector.

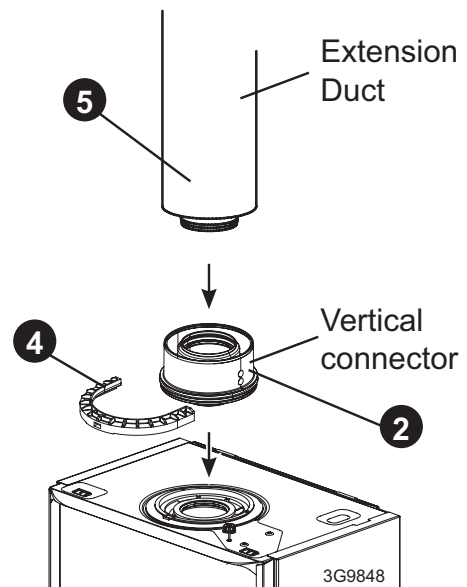

6. If the last extension duct requires cutting, measure 'X', the distance (outer ducts), between the duct and the terminal and add 100 mm to this dimension. This gives the length of the last extension duct.

Note. Check the position of the inner flue duct relative to the outer duct on the assembled extension duct(s) and ensure the terminal flue duct is cut longer than the air duct to ensure engagement in the final flue duct seal.

7. Finally ensure the roof flashing plate is correctly sealed to the roof.

INSTALLATION

29 CONNECTIONS & FILLING

NOTES.

Ensure all boss blanking plugs are removed before connecting hardware. Each valve must be fitted to the correct boss as shown in the picture.

Ensure each union is fitted with fibre seals provided.

Do not subject any of the isolating valves to heat as the seals may be damaged.

Note. The domestic hot water flow rate is automatically regulated to a maximum:

| | |
|---------------|-----------|
| 24 = 9.9 l/m | (2.2 gpm) |
| 30 = 12.4 l/m | (2.8 gpm) |
| 35 = 14.5 l/m | (3.2 gpm) |

WATER CONNECTIONS CH

1. Connect the CH flow service valve and copper tail provided in the hardware pack to the threaded boss connection provided at the lower rear of the boiler.
2. Connect the CH rtn. valve (black handle) and copper tail.
3. If connecting the boiler to heating loads in excess of 60,000 Btu/h, connecting flow and return heating systems pipework must be sized in 28mm diameter at the point of pipe connection to the boiler tails. use 22mm x 28mm pipe adaptors as appropriate.

WATER CONNECTIONS DHW

1. Fit the DHW inlet service valve (blue handle) and copper tail to the threaded boss connection ensuring the seal provided is correctly located.
2. Fit the DHW outlet pipe tail to DHW outlet connection, ensuring the seal provided is correctly located.
3. Fit the filling loop provided between the DHW inlet valve and the CH return valve

GAS CONNECTION

IMPORTANT. The gas service cock is sealed with a non-metallic blue fibre washer, which must not be overheated when making capillary connections. Refer to Frame 1 for details of the position of the gas connection.

For additional gas supply info refer to "Gas Supply" on page 8.

SAFETY VALVE DRAIN

The safety valve connection, located at the bottom right-hand side of the boiler, comprises a 15mm diameter stub pipe. The discharge pipe should be positioned so that the discharge of water or steam cannot create a hazard to the occupants of the premises or damage the electrical components and wiring.

A purpose made safety valve drain pipe is provided with the boiler to allow safe discharge through a wall to the outside of the building. This is particularly relevant to 'high rise' installations but can be used for all installations.

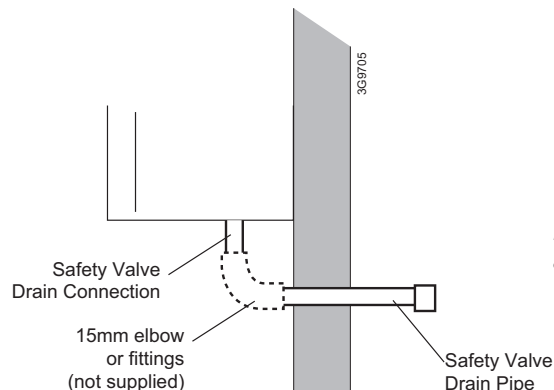

FILLING

IMPORTANT - when filling:

When filling, there may be a slight water leak from the air vent therefore electrical connections should be protected.

1. Ensure Filling Loop is connected
2. Ensure dust cap on auto air vent is slackened off (refer to Frame 66).
3. Check all isolation handles on all water connections are in the open position.
4. Open the blue handle on the filling loop, then slowly open the black handle until pressure gauge reads between 1 to 1.5 bar.
5. Once pressure gauge dial reads between 1 - 1.5 bar turn the filling loop isolation valves back to the closed position.
6. Disconnect filling loop at the LH side, ensuring top hat washer is retained and screw on blanking cap.
7. Connect extended blanking cap and top hat washer to filling loop pipe.

Note. Fully open all DHW taps and ensure water is flowing freely. Once satisfied close all taps.

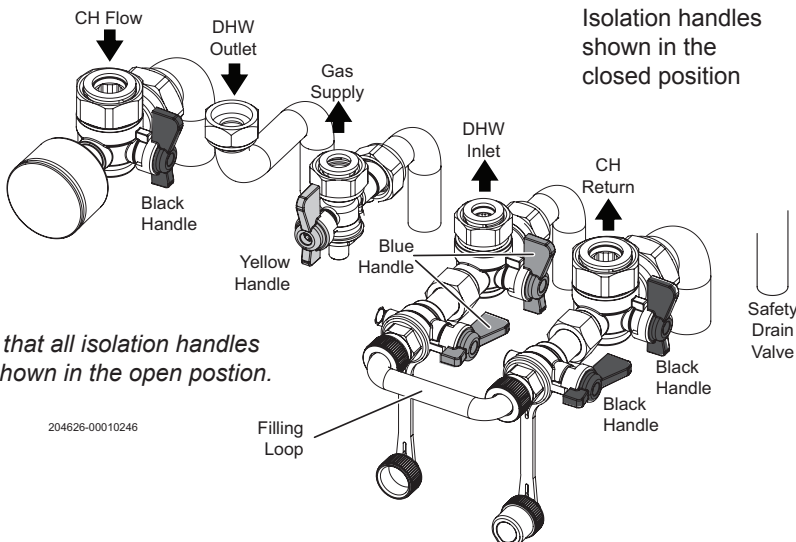
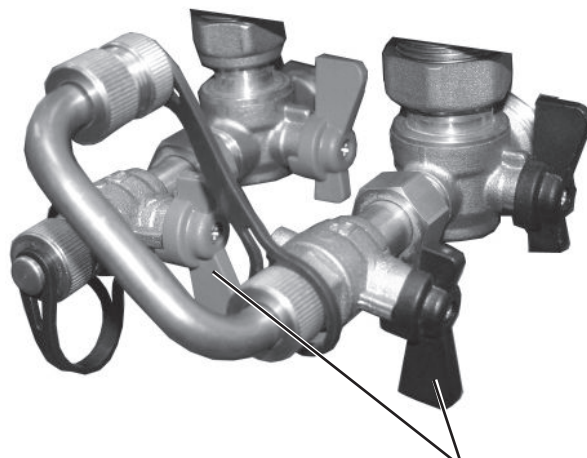

204626-00010246

30 ELECTRICAL CONNECTIONS

WARNING. This appliance **MUST** be earthed.

A mains supply of 230Vac ~ 50 Hz is required.

The fuse rating should be 3A. All external controls and wiring must be suitable for mains voltage.

Wiring external to the boiler **MUST** be in accordance with the current I.E.E. (BS.7671) Wiring Regulations and any local regulations.

Wiring should be 3 core PVC insulated cable, not less than 0.75mm² (24 x 0.2mm), and to BS 6500 Table 16. For IE reference should be made to the current ETCI rules for electrical installations.

Connection must be made in a way that allows complete isolation of the electrical supply such as a double pole switch having a 3mm (1/8") contact separation in both poles. The means of isolation must be accessible to the user after installation.

31 INTERNAL WIRING

The Logic + Combi boiler comes pre-fitted with 1.8m of mains cable. This must be connected to a permanent live supply and **NOT** switched by thermostats/programmers. For installers wishing to change this cable refer to Frame 33.

The Logic + Combi boiler comes pre-fitted with a link wire between the room thermostat/Timer connections on the terminal strip. This creates a permanent call for heat and must be removed when adding a room thermostat/ programmer.

The terminal block cover carries two spare fuses for the main PCB.

To add thermostat/programmer:

1. Isolate the mains supply to the boiler.
2. Remove the front panel. Refer to Frame 43.
3. Swing the control box down into the servicing position. Refer to Frame 49.
4. Route incoming cables through the grommets in bottom panel (note, grommets are 'blind' and will require puncturing) and secure using clamps and screws provided in hardware pack.
5. Pull off rubber terminal block cover.
6. Connect wires to terminal block, as shown below
7. Re-assemble in reverse order.

Spare PCB fuses

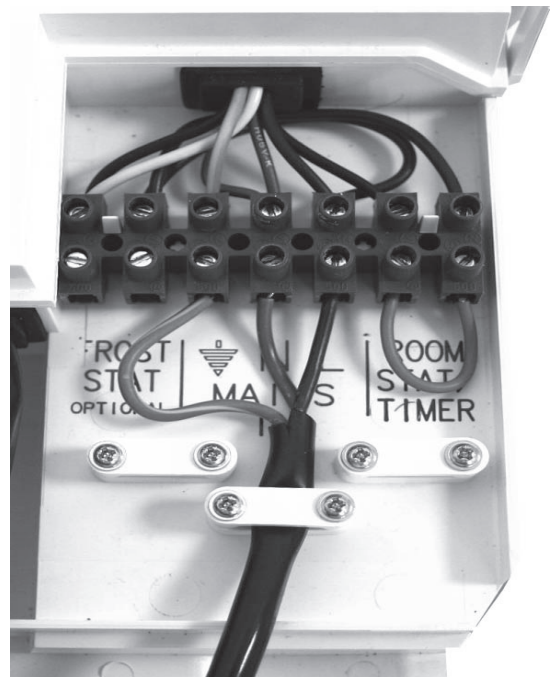
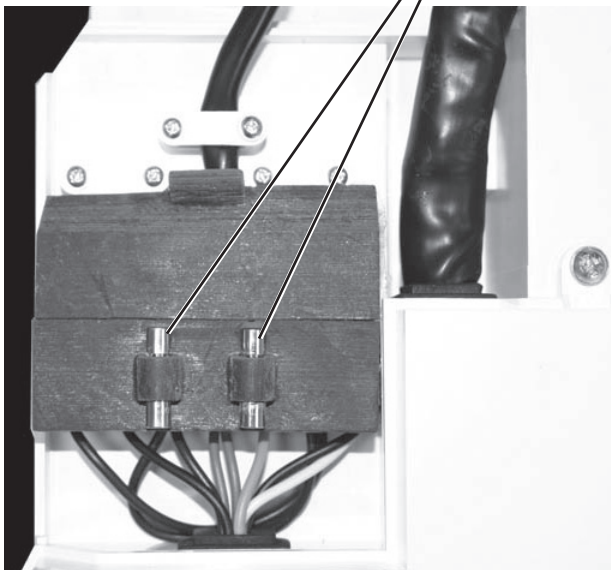

continued

32 INTERNAL WIRING CONT'D

Ideal offer 5 kits as follows:
(see individual kits for installation instructions)

Mechanical Timer (24 hr) Kit - 24 hour mechanical CH timer fits into the control box of the boiler. This can be fitted in conjunction with a room thermostat.

Electronic Timer (7 day) kit - 7 day electronic CH timer fits into the control box of the boiler. This can be fitted in conjunction with a room thermostat. Features English language installation help messages.

RF Mechanical Programmable Room Thermostat (24 hr) kit - Combined 24 hour mechanical timer and room thermostat with wireless communication to receiver unit which fits into control box of the boiler.

RF Electronic Programmable Room Thermostat (7 day) kit - Combined 7 day timer and room thermostat with wireless communication to receiver unit which fits into control box of the boiler. Features English language installation help messages. Also OpenTherm Control for gas consumption saving.

Weather Compensation Kit -
Allows outside temperature sensing.

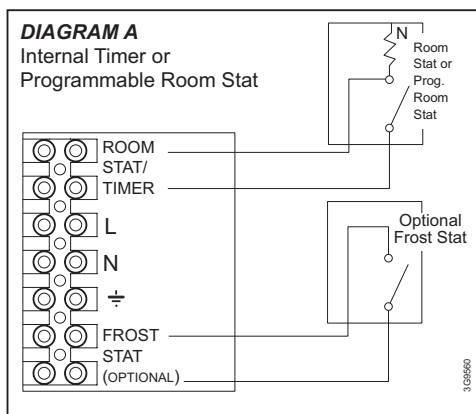

(1) ROOM THERMOSTAT WITH INTERNAL BOILER TIMER OR (2) PROGRAMMABLE ROOM THERMOSTAT

1. Remove link wire between room stat/timer terminals.
2. Connect room stat across terminals as shown in diagram A
3. If room stat has a neutral connection, connect this to terminal N (load) in the fused spur.

ROOM THERMOSTAT + TIMER

1. Remove link wire between room stat/timer terminals.
2. Connect room stat and programmer in series as shown in diagram B.
3. If room stat has a neutral connection, connect this to terminal N (load) in the fused spur.

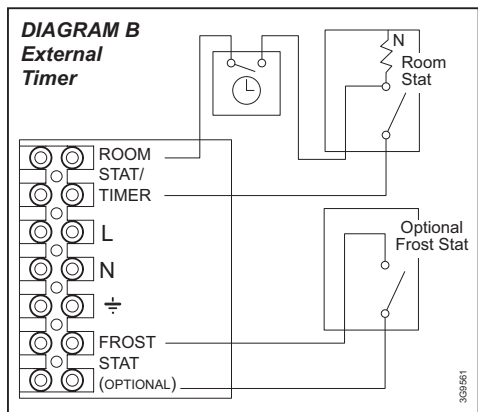

FROST THERMOSTAT

If parts of the system are vulnerable to freezing or the programmer is likely to be left off during cold weather, a frost stat should be fitted in conjunction with a pipe thermostat.

1. Position the frost thermostat in a suitable position, i.e. area vulnerable to freezing.
2. Connect frost stat across terminals marked frost stat shown in diagrams A & B.

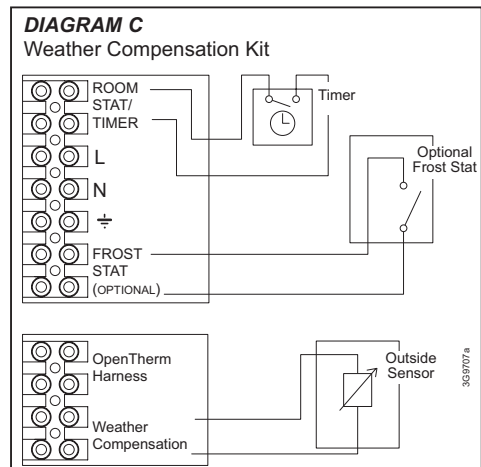

WEATHER COMPENSATION KIT

The two wires from the weather compensation kit (outside sensor), must be connected into the two right hand terminals as shown in diagram C.

33 REPLACING PRE-FITTED MAINS CABLE

If it is necessary to use an alternative mains cable to the one pre-fitted then use the following guide.

Replacement wiring should comply with notes in Frame 30.

1. Isolate the mains supply to the boiler.
2. Remove the front panel. Refer to Frame 43.
3. Swing the control box down into the service position. Refer to Frame 49.
4. Remove the live, neutral and earth wires from the terminal block.
5. Loosen the cable clamp and withdraw the mains cable.
6. Route replacement cable back through the cable clamp and grommet and re-tighten to provide cord anchorage.
7. Connect the live, neutral and earth wires to the terminal strip.

When making the mains electrical connections to the boiler it is important that the wires are prepared in such a way that the earth conductor is longer than the current carrying conductors, such that if the cord anchorage should slip, the current carrying conductors become taut before the earthing conductor.

8. Swing the control box back up into the operating position and re-fit the front panel ensuring a good seal is made.

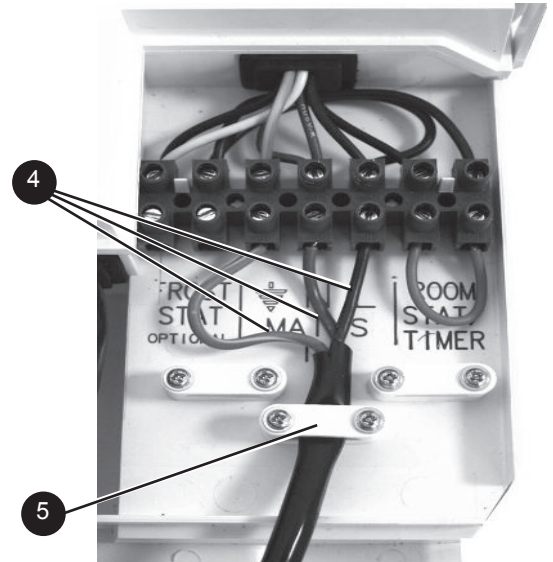

34 EXTERNAL ELECTRICAL CONTROLS

Wiring External to the Boiler

The fuse rating should be 3A.

Wiring external to the boiler MUST be in accordance with the current I.E.E. (BS.7671) Wiring Regulations and any local regulations.

Frost Protection

If parts of the pipework run outside the house or if the boiler will be left off for more than a day or so then a frost thermostat should be wired into the system.

This is usually done at the programmer, in which case the programmer selector switches are set to OFF and all the other controls MUST be left in the running position.

The frost thermostat should be sited in a cold place but where it can sense heat from the system.

Note. If the boiler is installed in a garage it may be necessary to fit a pipe thermostat, preferably on the return pipework.

Earths are not shown for clarity but must never be omitted.

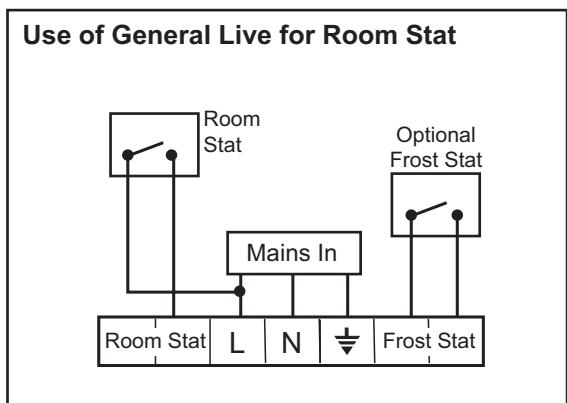

3G9503

OpenTherm Programmable Room Temperature Control

Note. These terminals MUST ONLY be connected to an OpenTherm Controller. Connecting any other device / control wiring may destroy the primary PCB.

1. Isolate the mains supply to the boiler.
2. Remove the front panel. Refer to Frame 43.
3. Swing the control box down into the servicing position. Refer to Frame 49.
4. Remove the control box cover. Refer to Frame 60, no's 3 and 4.
5. Unclip the 3 way in-line connector containing 2 purple wires and 2 red wires.
6. Connect this 3 way connector to the 3 way connector containing 2 purple wires wired from the 4 way terminal block.
7. Connect the two wires from the OpenTherm Programmable Room Temperature Control to the two LH connections of the terminal block as shown.
8. Re-assemble in reverse order.

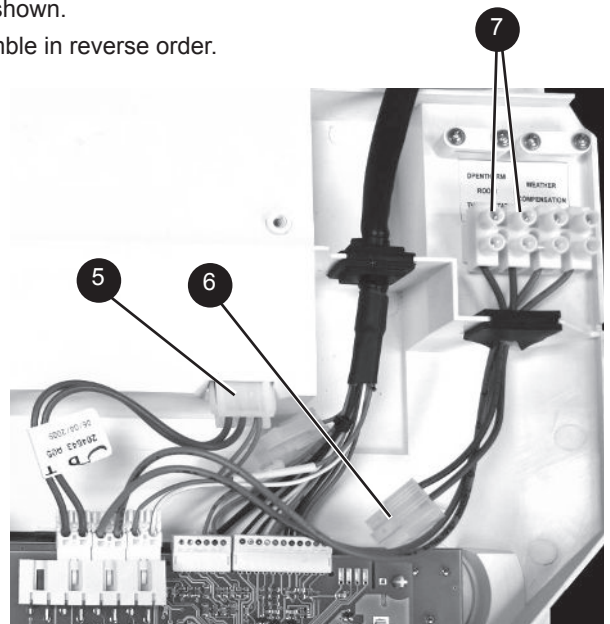

35 WIRING DIAGRAM

INSTALLATION

PCB

KEY

| | |
|-----|----------------|
| b | - blue |
| bk | - black |
| br | - brown |
| r | - red |
| p | - pink |
| y | - yellow |
| w | - white |
| y/g | - yellow/green |
| g | - grey |
| or | - orange |
| v | - violet |

Fused at 4AT

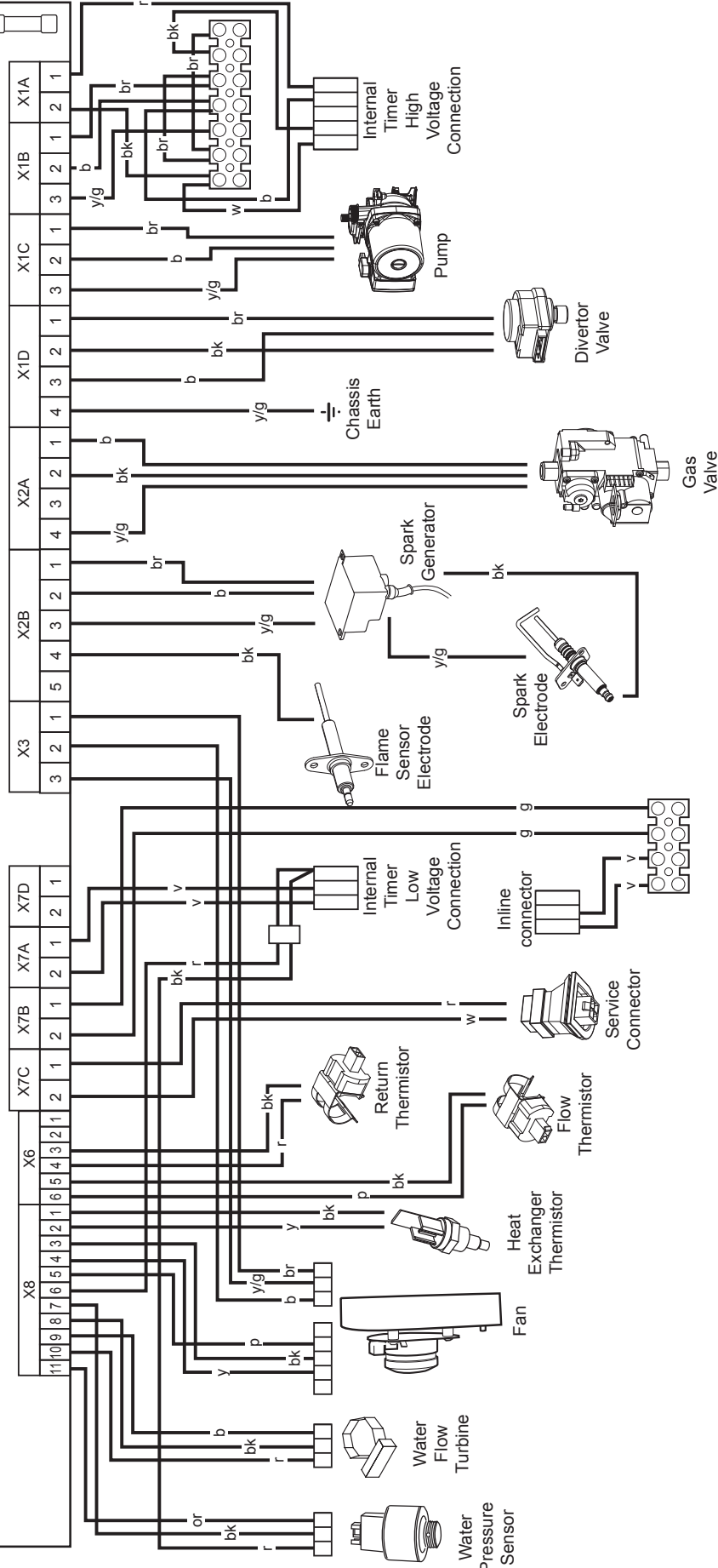

204978-9709D

36 COMMISSIONING AND TESTING

A. Electrical Installation

1. Checks to ensure electrical safety should be carried out by a competent person.
2. ALWAYS carry out the preliminary electrical system checks, i.e. earth continuity, polarity, resistance to earth and short circuit, using a suitable test meter.

B. Gas Installation

1. The whole of the gas installation, including the meter, should be inspected and tested for tightness and purged in accordance with the recommendations of BS. 6891. In IE refer to IS.813:2002.
2. Purge air from the gas installation by the approved methods only.

WARNING. Whilst effecting the required gas tightness test and purging air from the gas installation, open all windows and doors, extinguish naked lights and **DO NOT SMOKE.**

GENERAL

Please Note: The combustion for this appliance has been checked, adjusted and preset at the factory for operation on the gas type defined on the appliance data plate. No measurement of the combustion is necessary. **DO NOT** adjust the air/gas ratio valve.

Having checked:

- That the boiler has been installed in accordance with these instructions.
- The integrity of the flue system and the flue seals, as described in the Flue Installation section.

Proceed to put the boiler into operation as follows:

CHECK THE OPERATIONAL (WORKING) GAS INLET PRESSURE

Set up the boiler to operate at maximum rate by opening hot tap to maximum flow.

With the boiler operating in the maximum rate condition check that the operational (working) gas pressure at the inlet gas pressure test point complies with the requirements - refer to "Gas Supply" on page 8.

Ensure that this inlet pressure can be obtained with all other gas appliances in the property working.

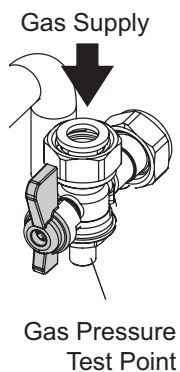

ATTENTION !
IT IS A CONDITION OF THE MANUFACTURERS WARRANTY THAT THE BENCHMARK COMMISSIONING CHECKLIST IS FULLY COMPLETED AND LEFT WITH THE APPLIANCE

INSTALLATION

37 INITIAL LIGHTING

Legend

- A. Pre-heat On/off
- B. DHW temperature control
- C. CH temperature control
- D. Off/Summer/Winter/Reset Control
- E. Boiler Status
- F. Burner 'on' indicator
- G. CH Flow Isolating Valve
- H. Pressure Gauge
- J. Gas Inlet Pressure Test Point
- K. Gas Service Cock
- L. DHW Inlet Valve
- M. CH Return Isolating Valve
- N. DHW Outlet

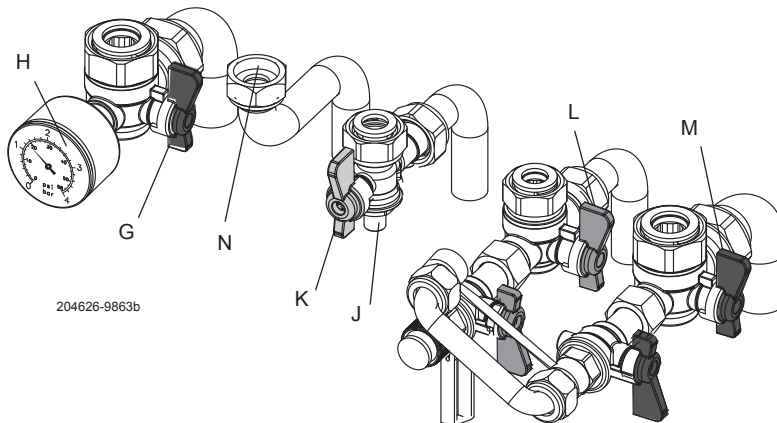
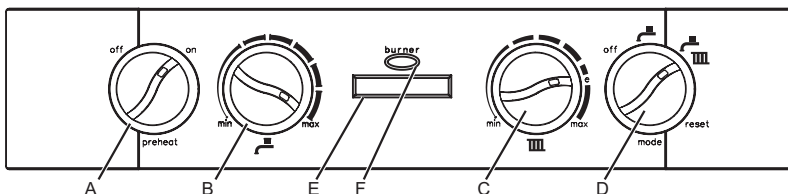

204626-9863b

1. Check that the system has been filled and that the boiler is not airlocked. Ensure the automatic air vent cap is open. Refer to Frame 29.

Note.

It is important the burner is not operated before the system is fully vented of air. If it is necessary to operate the appliance pump to assist venting of the air this must be done with the gas service cock turned off.

2. Refit the boiler front panel. Refer to Frame 44.
3. Check that the drain cock is closed and that the CH and DHW isolating valves (M, L and G) are OPEN.
4. Check that the electrical supply is OFF.
5. Check that the boiler mode control knob (D) is off.
6. Check that the gas service cock (K) is OPEN.
7. Slacken the screw in the inlet pressure test point (J) and connect a gas pressure gauge via a flexible tube.
8. Switch the electricity supply ON and check all external controls are calling for heat.

CENTRAL HEATING

9. Set the CH temp control (C) to max and turn the mode control knob (D) to , ensure the timer/room stat are on. The boiler control will now go through its ignition sequence until the burner is established.
10. If the boiler does not light the following messages will be displayed in rotation "**Ignition Lockout**" - "**1 Check other gas appliances**" - "**2 Reset boiler**" - "**3 Contact installer**". After 5 attempts the boiler will lock out and carry on displaying the messages. Reset the boiler (refer to Frame 39B). The boiler will repeat its ignition sequence. If reset occurs 5 times within 15 minutes then "**Too many resets**" will be shown. If power is removed this will be reset.

When the burner is established the BLUE 'Burner On' neon (F) will be illuminated, the LCD will display "**Central Heating**" and "**Radiator Temp XX°C**".

DOMESTIC HOT WATER

11. With the boiler firing, set the DHW Temp Control knob (B) to maximum and fully open a DHW tap.

The boiler will continue to run and the display (E) will show "**Hot Water**" - "**Temperature XX°C**" - "**High Efficiency**".

12. Ensure that with the boiler operating the dynamic gas pressure is able to obtain maximum output. Refer to Table 2.

IMPORTANT

The gas input to the burner is regulated by the gas valve according to the air flow produced by the fan. It is NOT user-adjustable. Any interference to sealed settings on the gas valve will adversely affect operation and render our warranty void.

For additional gas supply information refer to "Gas Supply" on page 8

13. Turn off the DHW tap.

Note. The temperature displayed "XX°C" is that measured at that moment, not the set temperature.

Note. The boiler incorporates a fan overrun cycle which MUST NOT be prematurely interrupted by isolation of the mains electricity supply.

continued.

INSTALLATION

38 INITIAL LIGHTING CONT'D

THE DISPLAY

The user control has one neon and one display to inform the user about the status. The display will show the status of the boiler. The neon will show the status of the flame. If no flame is detected the neon is off. When the flame is detected the neon will be lit permanently.

The display scrolls through a maximum of 3 messages under any operational condition as shown below.

Notes: *Boiler frost protection - boiler fires if temperature is below 5° C.
The temperatures shown below are for illustration purposes only. The measured temperatures will be shown on the boiler.*

DISPLAY FUNCTIONS IN NORMAL OPERATION

| NORMAL OPERATION | MESSAGE 1 | MESSAGE 2 | MESSAGE 3 |
|--|-------------------------|--|--|
| Mode knob in standby position and no heat demand | Standby mode | For hot water turn mode knob clockwise | For central heating turn mode knob clockwise twice |
| Mode knob in summer position and no heat demand | Summer mode | For central heating turn mode knob clockwise | |
| Mode knob in winter position and no heat demand | Winter mode | Timer or room stat off | |
| Domestic hot water operation | Hot water | Temperature 64°C | High efficiency |
| Central heating operation | Central heating | Radiator Temp 80°C | High efficiency |
| Pre-heat operation | Pre heat | Temperature 59°C | High efficiency |
| Boiler frost protection | Boiler frost protection | Temperature 5°C | High efficiency |
| Pump overrun | Pump overrun | | |
| Fan post-purge | Fan post-purge | | |

3G9711

Note. High efficiency will not be shown for central heating operation if the central heating flow temperature knob is set to greater than 73°C.

DISPLAY FUNCTIONS - SETTINGS CHANGED

| NORMAL OPERATION | MESSAGE 1 | MESSAGE 2 | MESSAGE 3 |
|-------------------------------------|---------------|-----------------------------------|---|
| Pre-heat knob moved to off position | Pre heat off | | |
| Pre-heat knob moved to on position | Pre heat on | | |
| DHW temperature knob moved | 64°C DHW temp | Hot water temperature 64°C | May not be achieved for high flow rates in winter |
| CH temperature knob moved | 80°C CH temp | Maximum radiator temperature 80°C | |
| Mode knob moved to standby position | Standby mode | Central heating off | Hot water off |
| Mode knob moved to summer position | Summer mode | Central heating off | Hot water on |
| Mode knob moved to winter position | Winter mode | Central heating on | Hot water on |
| Mode knob moved to reset position | Reset | | |

3G9712

INSTALLATION

39 INITIAL LIGHTING . . . CONT'D

INSTALLER MODE

Installer Mode is entered as follows:

1. Turn the DHW temperature control knob full anti-clockwise.
2. Turn the CH flow temperature control knob full anti-clockwise.
3. Turn and hold the mode knob in the reset position for more than 5 secs and then turn it to the Winter or Summer position.

The boiler will display **"Installer mode"**.

If no faults have occurred the boiler will display **"No faults"**.

If any faults have occurred a list of faults up to a maximum of 10 including the type of fault and how long ago it occurred will be shown in the following format.

| MESSAGE 1 | MESSAGE 2 | MESSAGE 3 |
|------------------------|-----------------------|--------------|
| LIST OF FAULTS | | |
| Fault 1 (latest fault) | Low water pressure | 2 days ago |
| Fault 2 | No water flow lockout | 78 days ago |
| Fault 3 | Overheat lockout | 384 days ago |

The boiler will then display the current values of flow temperature, return temperature, domestic hot water temperature, DHW flow rate and diverter valve position in the following format:

| MESSAGE 1 |
|-----------------------------|
| CURRENT VALUES |
| Flow temp 80°C |
| Return temp 60°C |
| DHW temp 64°C |
| DHW flow rate 8 l/min |
| Diverter valve DHW position |

Note.

If you would like to hold one of the values on the display to watch its behaviour then turn the reset knob to the reset position while it is displayed and hold it there.

Finally the display will operate in one of two modes. If there is a fault then more extensive corrective actions will be shown than are usually displayed for the end user. If there is not a fault then the information displayed for current operating states will also be more extensive than is usually displayed for the end-user (pre-purge, ignition and post purge for example).

Installer mode automatically ends after 10 mins or by moving the mode knob to the standby position.

39B RESET PROCEDURE

To reset boiler, turn the mode control knob (D) to reset position and immediately turn knob back to required setting. The boiler will repeat the ignition sequence.

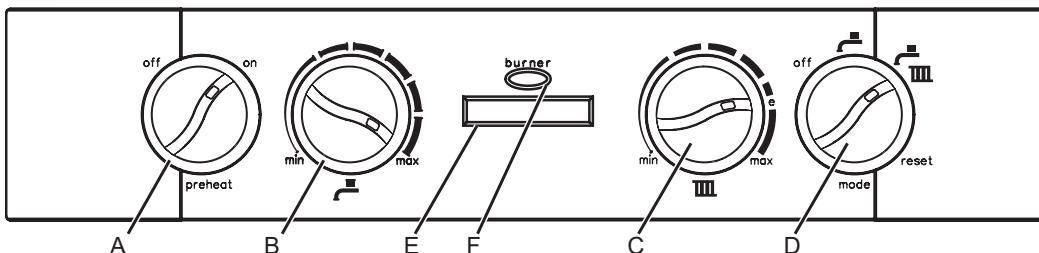

Legend

- A. Pre-heat On/off
- B. DHW temperature control
- C. CH temperature control
- D. Off/Summer/Winter/Reset Control
- E. Boiler Status
- F. Burner 'on' indicator

40 GENERAL CHECKS

Make the following checks for correct operation in:

DOMESTIC HOT WATER (DHW) MODE

1. Fully open all DHW taps in turn and ensure that water flows freely and that the mode knob is either in summer or winter position. The boiler will display

“Hot Water” - “Temperature XX°C” - “High Efficiency”

where the temperature shown is the current Domestic Hot Water temperature.

When the burner is lit the light above the display will be on.

2. Close all taps except the furthest one from the boiler and check that the boiler is firing at maximum rate.

This is factory set to give a DHW temperature rise of approximately 35°C at the flow rate stated on page 6 under “operation”.

3. Reduce the DHW draw-off rate to about 3 l/min (0.7gpm) and check that the boiler modulates to deliver DHW at approximately 64°C (with the DHW temperature control knob set to maximum).
4. Close the DHW tap and check that the main burner extinguishes. The pump should overrun for 60 seconds during which the boiler will display **“Pump overrun”**. The fan will then continue to run for a further 3 minutes during which the boiler will display **“Fan Post Purge”** after which the boiler will display one of the following **“Standby mode” - “Summer mode” - “Winter Mode”** depending on the position of the mode knob.

Note. On systems in excess of 2 bar inlet pressure a water pressure governor may be required to prevent water noise.

CH & DHW MODE

1. Ensure the CH controls are calling for heat and that the boiler mode knob is in the winter position and the CH flow temperature control knob is in the maximum position. The Boiler will display

“Central Heating” - “Radiator Temp XXC”

where the temperature shown is the current flow temperature.

When the burner is lit the light above the display will be on.

2. Fully open the DHW tap and check that hot water is delivered. The boiler will display **“Hot water” - Temperature XX°C - High Efficiency”**

3. Gas Rate

Check the boiler gas rate when the boiler is at full DHW output. Check at the gas meter, with no other appliance in use. Refer to Tables 2 and 3 for gas rates.

4. Close the DHW tap. The burner should remain on and the boiler will display **“Central heating” - “Radiator temp XXC”**.
5. Set the central heating external controls to off. The burner will go off and the fan and pump continue to run for 4 minutes. The boiler will display **“Pump overrun”** after which the boiler will display one of the following: **“Standby mode” - “Summer mode” - “Winter mode”** depending on the position of the mode knob.
6. Check the correct operation of the timer (if fitted) and all other system controls. Operate each control separately and check that the main burner responds.

Note. The temperature displayed “XX°C” is that measured at that moment, not the set temperature.

WATER CIRCULATION SYSTEM

1. With the system COLD, check that the initial pressure is correct to the system design requirements.

For pre-pressurised systems, this should be 1.0 bar.

2. With the system HOT, examine all water connections for soundness. The system pressure will increase with temperature rise but should not exceed 2.5 bar.
3. With the system still hot, turn off the gas, water and electricity supplies to the boiler and drain down to complete the flushing process.

Note: A flushing solution should be used during the flushing procedure. Flushing solutions: Fernox Superfloc, Sentinel X300 (new systems) or X400 (existing systems). Refer to Frame 5.

4. Refill and vent the system, add inhibitor (see Frame 5), clear all air locks and again check for water soundness.
5. Reset the system initial pressure to the design requirement.
6. Balance the system. Refer to Frame 4.
7. Check the condensate drain for leaks and check that it is discharging correctly.

8. Finally, set the controls to the User's requirements.

Notes.

1. If the pump has not operated in the last 24 hours it will run briefly to prevent seizure
2. If the diverter valve has not operated in the last 24 hours it will be operated briefly to prevent seizure. These two operations will not occur at the same time.

WATER TEMPERATURES

Temperatures can be selected using the CH and DHW thermostats.

| Knob Setting | CH Flow Temp °C (°F) | DHW Outlet Temp °C (°F) |
|--------------|-------------------------|----------------------------|
| Max | 80 (176) | 64 (147) |
| Min | 45 (113) | 40 (104) |

41 HANDING OVER

After completing the installation and commissioning of the system the installer should hand over to the householder by the following actions:

1. Make the householder aware that the user instructions are located in the pocket in the drop down door and explain his/her responsibilities under the relevant national regulations.
2. Explain and demonstrate the lighting and shutting down procedures.
3. The operation of the boiler and the use and adjustment of all system controls should be fully explained to the householder, to ensure the greatest possible fuel economy consistent with the household requirements of both heating and hot water consumption.

Advise the User of the precautions necessary to prevent damage to the system and to the building, in the event of the system remaining inoperative during frosty conditions.

4. Explain the function and the use of the boiler heating and domestic hot water controls.

Explain that due to system variations and seasonal temperature fluctuations DHW flow rates/temperature rise will vary, requiring adjustment at the draw off tap. It is therefore necessary to draw the users attention to the section in the Users Instructions titled "Control of Water Temperature" and the following statement:

"Additionally, the temperature can be controlled by the user via the draw-off tap: the lower the rate the higher the temperature, and vice versa".

5. Explain the function of the boiler fault mode.
Emphasise that if a fault is indicated, the boiler should be turned off and a Gas Safe Registered Engineer consulted. In IE contact a Registered Gas Installer (RGI).
6. Explain and demonstrate the function of time and temperature controls, radiator valves etc., for the economic use of the system.
7. If a timer is fitted draw attention to the timer Users Instructions and hand them to the householder.

8. Loss of system water pressure

Explain that the dial underneath the boiler indicates the central heating system pressure and that if the normal COLD pressure of the system is seen to decrease over a period of time then a water leak is indicated. Explain the re-pressurising procedure and if unable to re-pressurise or if the pressure continues to drop a registered local heating installer should be consulted.

9. Explain boiler reset procedure (refer to Frame 39B).

10. After installation and commissioning please complete



the Commissioning Checklist before handover to the customer. For IE, its is necessary to complete a "Declaration of Conformity" to indicate compliance to I.S. 813:2002.

IMPORTANT

11. A comprehensive service should be carried out ANNUALLY.

Stress the importance of regular servicing by a Gas Safe Registered Engineer. In IE servicing work must be carried out by a Registered Gas Installer (RGI).

12. Inform the householder of the guarantee/registration found within the envelope pack and the requirement to register it to receive the full benefit of the warranty.

42 SERVICING SCHEDULE

For the very latest copy of literature for specification & maintenance practices, visit our website www.idealheating.com, where you will be able to download the relevant information. N.B. Technical Bulletins are also available on www.idealheating.com.

WARNING. Always turn OFF the gas supply at the gas service cock, and switch OFF and disconnect the electricity supply to the appliance before servicing.

Combustion testing must be carried out by a competent person using a combustion analyser conforming to BS7927.

To ensure the continued safe and efficient operation of the appliance it is recommended that it is checked at regular intervals and serviced as necessary. The frequency of servicing will depend upon the installation condition and usage but should be carried out at least annually.

It is the law that any service work must be carried out by a Gas Safe Registered Engineer. In IE service work must be carried out by a Registered Gas Installer (RGII).

INSPECTION

1. Light the boiler and carry out a pre-service check, noting any operational faults.
2. Check the flue terminal (and terminal guard if fitted) is undamaged and clear of any obstruction.
3. Check all water and gas joints for signs of leakage. Remake any suspect joints ensuring a gas tightness check is carried out if applicable and the water system is correctly refilled, vented and re-pressurised.

CLEANING PROCEDURE

Note. In order to carry out either servicing or replacement of components the boiler front panel must be removed. Refer to Frame 43.

1. Clean the main burner. Refer to Frame 45.
2. Clean the heat exchanger & condensate trap/siphon. Refer to Frames 46 & 47
3. Check the main injector for blockage or damage. Refer to Frame 51.
4. Check that the flue terminal is unobstructed and that the flue system is sealed correctly.

ALSO IF THE DHW FLOW RATE IS IN QUESTION :-

5. Check the DHW filter for blockage. Refer to Frame 72.

The cleaning procedures are covered more fully in Frames 44-48 and MUST be carried out in sequence.

IMPORTANT.

6. After completing the servicing or exchange of components always test for gas tightness.
7. When work is complete the front panel MUST be correctly refitted, ensuring that a good seal is made.

Do NOT OPERATE the boiler if the front panel is not fitted.

8. If, for any reason, the condensate trap/siphon has been removed ensure the trap is refilled with water before reassembling.
9. Check the gas consumption.
10. Check combustion by connecting the flue gas analyser to the flue gas sampling point as shown in the diagram and measure CO & CO₂.

If the CO/CO₂ ratio is greater than 0.004 AND the integrity of the complete flue system and combustion circuit seals have been verified and the inlet gas pressure (and gas rate) have been verified, then contact Ideal.

11. Complete the service section in the Benchmark Commissioning Checklist.

GENERAL

Please Note: During routine servicing, and after any maintenance or change of part of the combustion circuit, the following must be checked:

- The integrity of the flue system and the flue seals,
- The integrity of the boiler combustion circuit and the relevant seals
- The operational (working) gas inlet pressure at maximum rate.
- The gas rate
- The combustion performance.

COMPETENCE TO CARRY OUT THE CHECK OF COMBUSTION PERFORMANCE

Please Note: BS 6798:2009 Specification for installation and maintenance of gas-fired boilers of rated input not exceeding 70kW net advises that:

- The person carrying out a combustion measurement should have been assessed as competent in the use of a flue gas analyser and the interpretation of the results.
- The flue gas analyser used should be one meeting the requirements of BS7927 or BS-EN50379-3 and be calibrated in accordance with the analyser manufacturers requirements, and
- Competence can be demonstrated by satisfactory completion of the CPA1 ACS assessment, which covers the use of electronic portable combustion gas analysers in accordance with BS7967, Parts 1 to 4.

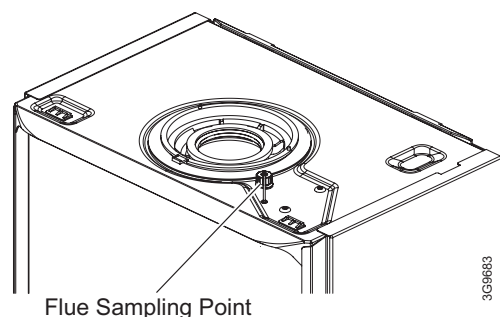

SERVICING

43 BOILER FRONT PANEL REMOVAL / REPLACEMENT

REMOVAL

1. Loosen the two screws retaining the front panel.
2. Pull the two spring clips down to disengage and pull panel forward and upward and remove.

REPLACEMENT

3. Hook the panel onto the top retaining clips.
4. Push the panel until the 2 bottom spring clips engage ensuring the 4 control knobs line up with the holes in the front panel.
5. Re-tighten the two retaining screws.

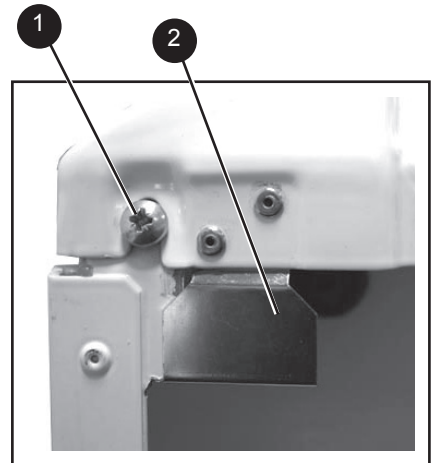

view from bottom of boiler

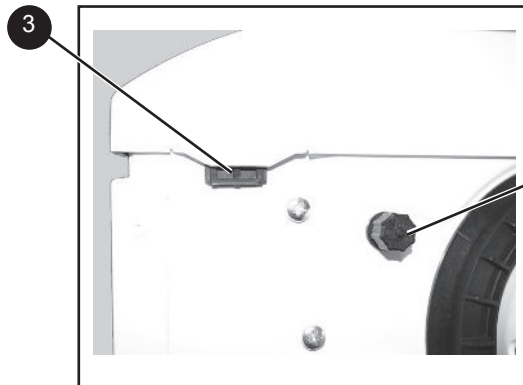

Flue sampling point

view from top of boiler

44 FAN AND VENTURI ASSEMBLY REMOVAL AND CLEANING

1. Disconnect the electrical leads from the fan.
2. Undo the gas pipe union connection to the injector housing.
3. Remove the extended nut on the fan mounting bracket.
4. Lift off fan and venturi assembly.
5. Inspect the injector for blockage or damage.
6. Inspect fan outlet sealing gasket and replace if necessary.

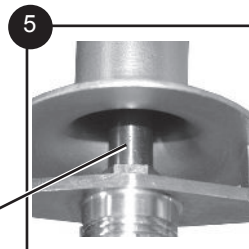
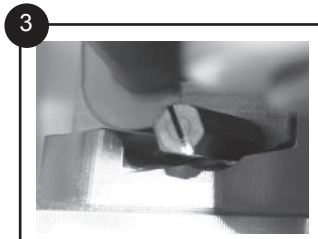

Injector

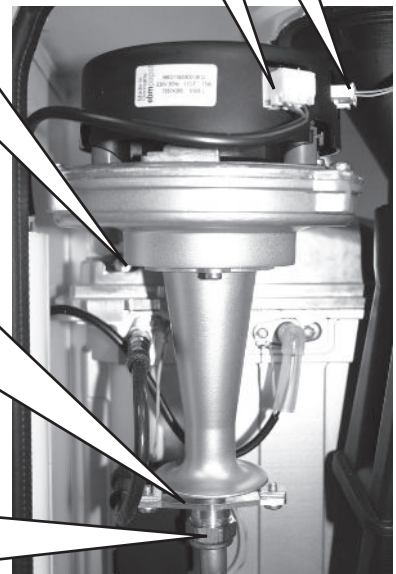
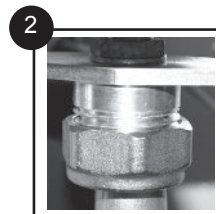

45 BURNER REMOVAL AND CLEANING

1. Ensure the sump is fully drained
2. Undo the two screws and remove the sump cover retaining the lower flue manifold.
3. Lift the manifold to clear the bottom sealing gasket and remove manifold.
4. Remove the 2 burner front fixing screws and loosen the 2 rear extended nuts by at least ten turns.
5. Lift off the burner from the combustion chamber. To facilitate the removal angle the burner as shown.

IMPORTANT

The burner head is a ceramic plaque construction. Care must be taken to ensure that **the burner is not placed down upon its face** as this may cause damage to the ceramic.

6. Brush off any deposits that may be on the ceramic with a SOFT brush.
7. Inspect the sealing gasket around the burner for any signs of damage. Replace as necessary.

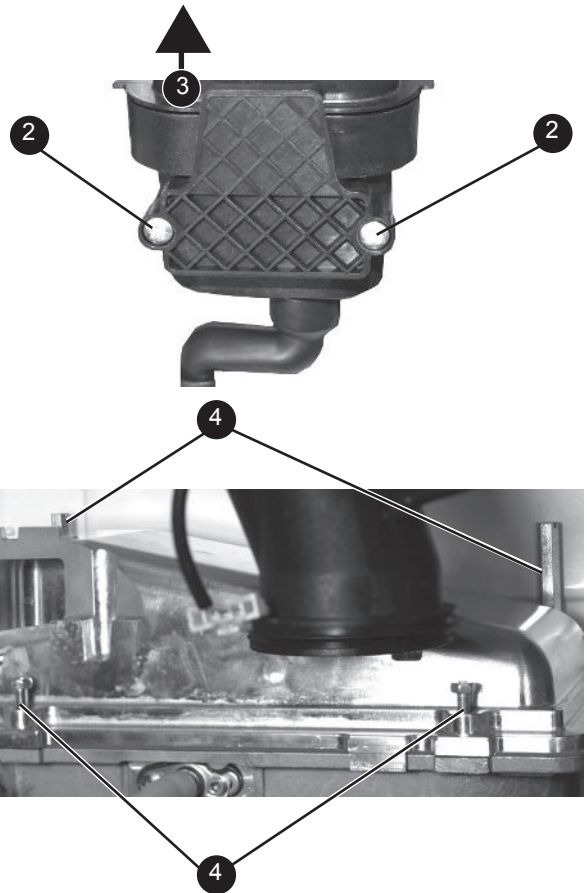

46 CLEANING THE CONDENSATE TRAP/SIPHON

1. Remove the cleaning plug taking care with any residual condensate.
2. Pull off the rubber pipe noting the position and flush out any deposits with clean water.
3. Replace the cleaning plug and refill the siphon with water.
4. Replace the rubber pipe connector with the twin wall seal fitted to the condensate siphon.

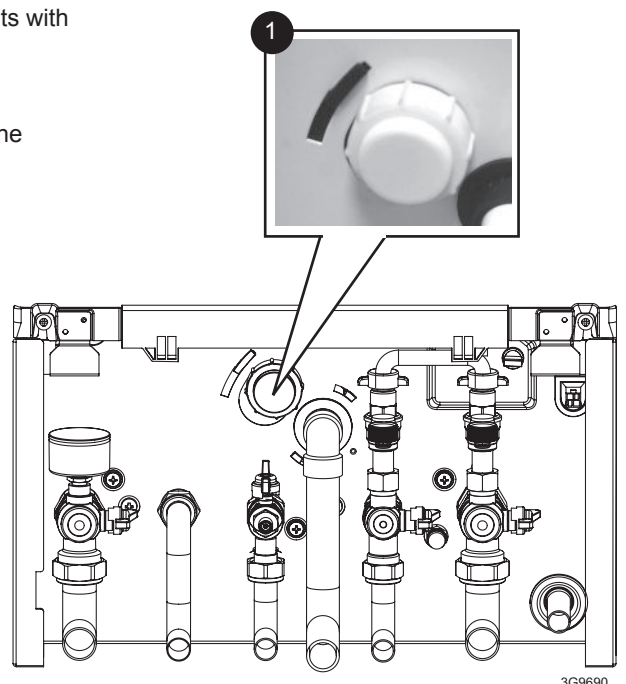
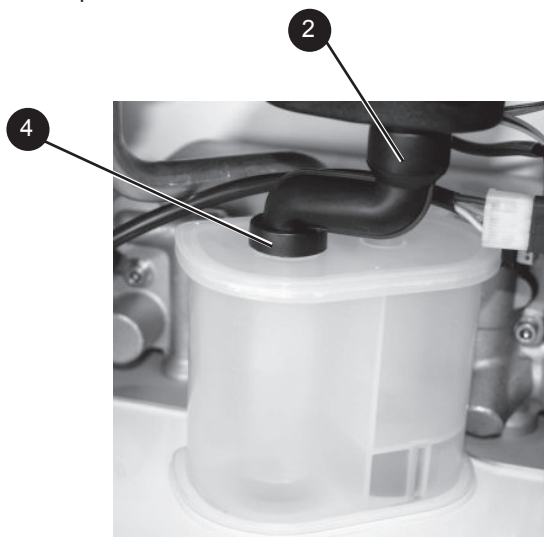

3G9690

47 CLEANING THE HEAT EXCHANGER

Note: Ensure the condensate trap/siphon is fully drained before cleaning. Refer to Frame 59.

1. Remove ignition and flame detection electrodes. Refer to Frames 54 & 55.
2. It is advisable to replace the sump cover prior to the water flush process.
3. Thoroughly flush the heat exchanger by pouring water into the top of the combustion chamber ensuring the full top area is covered.
4. Remove the sump cover and clean loose deposits from the sump.
5. Inspect the ignition and detection electrodes. Ensure that they are clean and in good condition - replace if necessary.
6. Re-fit the ignition and flame detection electrodes, ensuring that both earth tabs are fitted to ignition electrode.
7. Check that the ignition and detection gaps are correct. Refer to Frames 54 & 55.

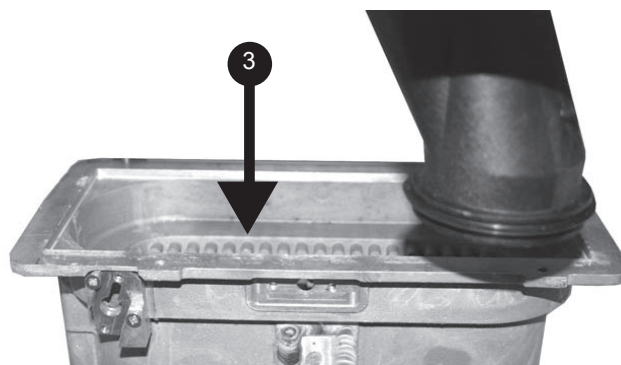
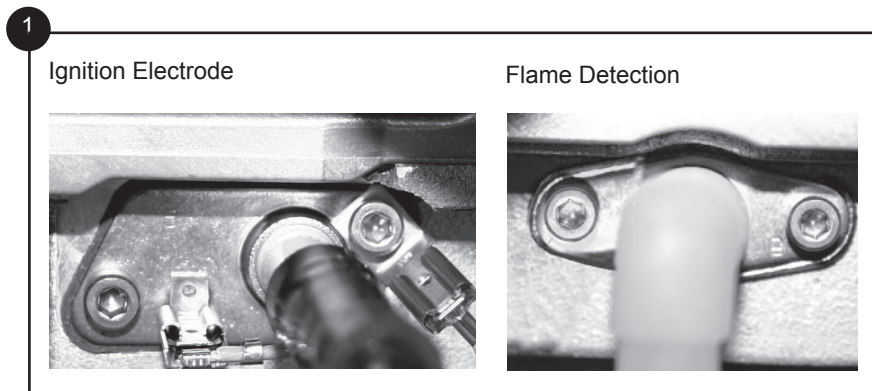

48 REASSEMBLY

Reassemble the boiler in the following order:

1. Ensure that the condensate trap/siphon is full of water.
 2. Refit the burner ensuring the sealing gasket is correctly positioned and free from damage (tighten the 4 fixing screws in the sequence shown below).
 3. Refit the fan / venturi assembly ensuring the retaining tabs are correctly positioned and the sealing gasket is correctly positioned and free from damage.
 4. Reconnect the fan electrical leads.
 5. Remove the sump cover and refit the lower flue manifold as shown.
 6. Refit the sump cover.
 7. Refit the boiler front panel.
- IMPORTANT.** Ensure that the boiler front panel is correctly fitted and that a good seal is made.
8. Swing the control box back into its working position and secure.
 9. Turn on the gas supply at the gas service cock.
 10. Reconnect the electrical supply.

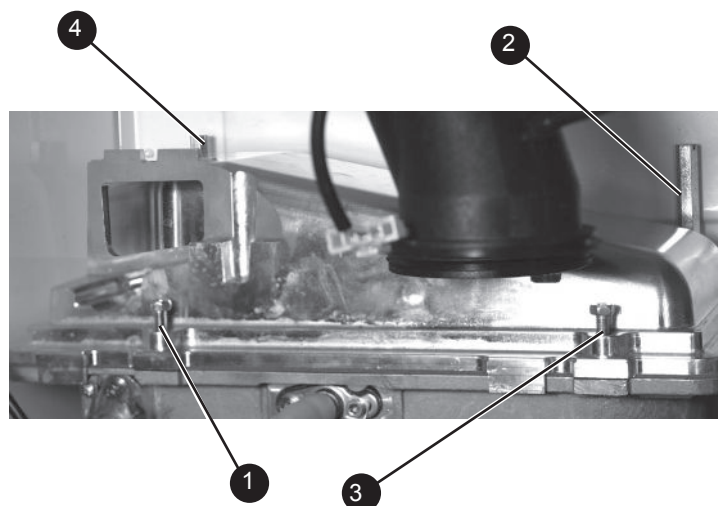

49 REPLACEMENT OF COMPONENTS

GENERAL

When replacing ANY component

1. Isolate the electricity supply.
2. Turn off the gas supply.
3. Remove the boiler front panel. Refer to Frame 43.
4. Release the retaining clip and swing the control box down into its servicing position.

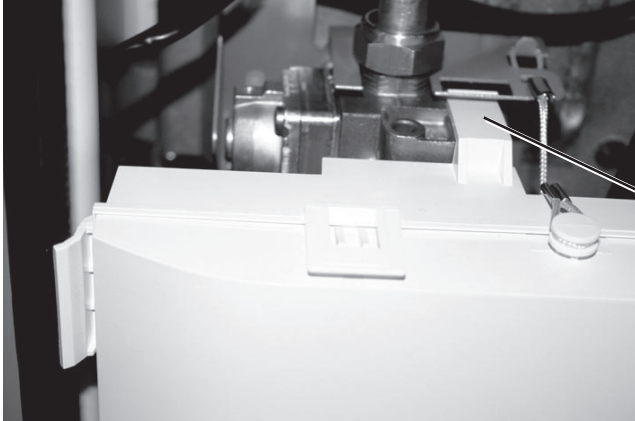

After replacing ANY component check operation of the boiler, including gas tightness, gas rate and combustion test.

IMPORTANT.

When work is complete, the front panel must be correctly refitted - ensuring that a good seal is made.

Notes.

1. In order to assist fault finding, the control panel has an LED diagnostic display. The key to boiler fault conditions is shown in Frame 77.
2. In order to replace components in Frames 64-75 it is necessary to drain the boiler. Refer to Frame 63.

THE BOILER MUST NOT BE OPERATED WITHOUT THE FRONT PANEL FITTED

50 FAN REPLACEMENT

1. Refer to Frame 49.
2. Disconnect the electrical leads from the fan.
3. Undo the gas pipe union connection to the injector housing.
4. Remove the extended nut retaining the fan mounting bracket.
5. Lift and remove the fan and venturi assembly.
6. Remove the screw and twist venturi anti-clockwise to remove venturi assembly, *noting the orientation of the venturi in relation to the fan body.*
7. Transfer the venturi assembly to the new fan, replacing the 'o' ring if evidence of damage or deterioration is visible.
8. Fit the new fan / venturi assembly ensuring the retaining tabs are correctly positioned and the fan outlet sealing gasket is correctly positioned and free from damage. Refit the extended nut.
9. Reassemble the boiler in reverse order, taking care not to overtighten the screw on the fan mounting bracket.
10. Check the operation of the boiler. Refer to Frames 37-40.

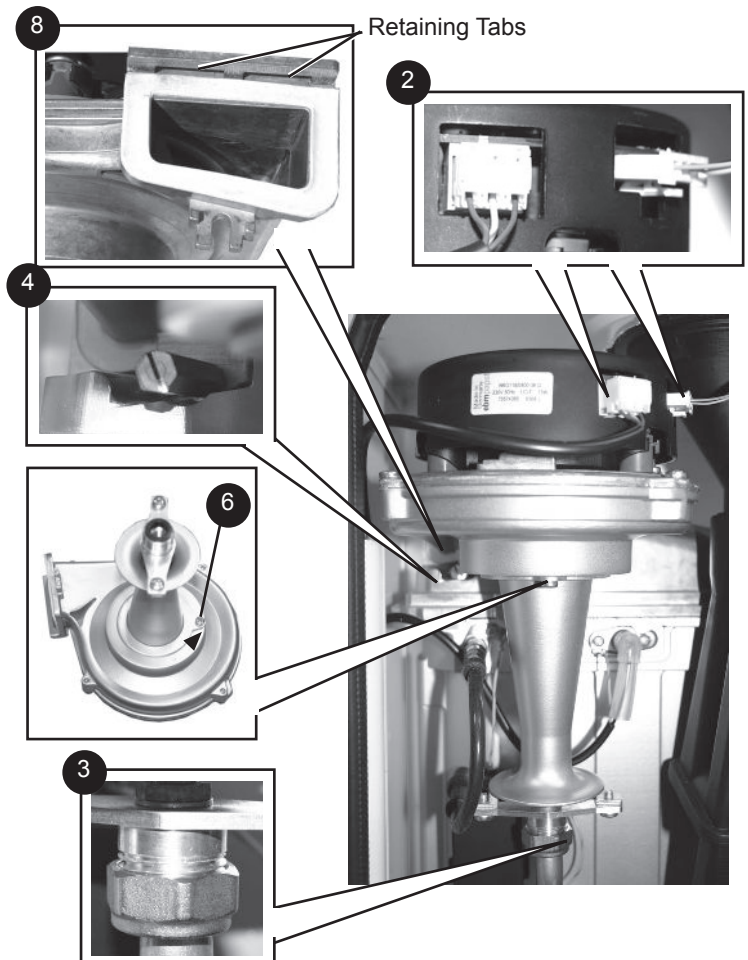

51 BURNER INJECTOR REPLACEMENT

1. Refer to Frame 49.
2. Disconnect the electrical leads from the fan.
3. Undo the gas pipe union connection to the injector housing.
4. Loosen the screw retaining the fan mounting bracket.
5. Lift and remove the fan and venturi assembly.
6. Remove the 2 injector housing screws.
7. Withdraw the injector housing.
8. Fit the new injector housing complete with injector.
9. Reassemble in reverse order, ensuring that the new gas seal supplied is located correctly in the injector housing.
10. Check operation of the boiler. Refer to Frames 37-40.

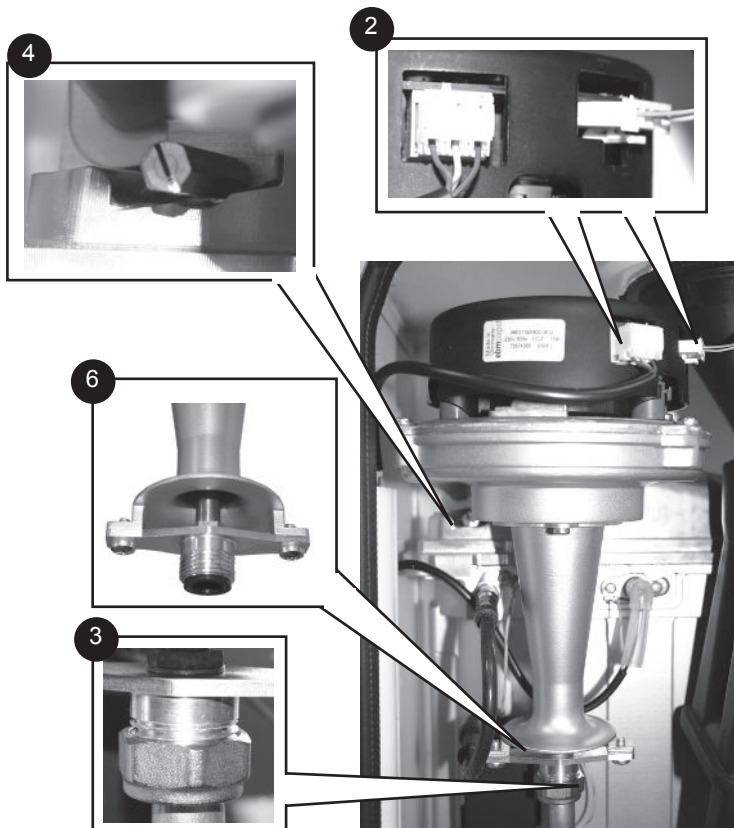

52 BURNER REPLACEMENT

1. See Frame 45.
2. Refer to Frame 49.
3. Undo the two screws and remove the sump cover.
4. Lift the manifold to clear the bottom sealing gasket and remove manifold.
5. Remove the 2 front fixing screws and loosen the 2 rear extended nuts.
6. Lift off the burner from the combustion chamber. To facilitate the removal angle the burner as shown.
7. Fit the new burner, replacing any damaged or deteriorating sealing gasket.
8. Reassemble in reverse order. Refer to Frame 48.
9. Check the operation of the boiler. Refer to Frames 37-40.

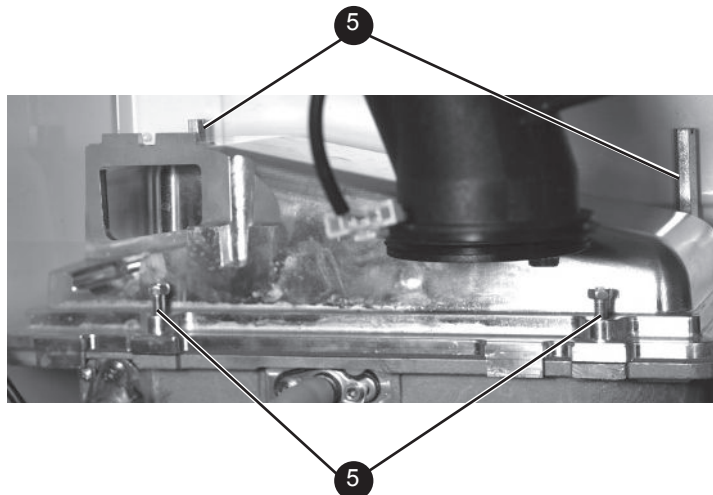
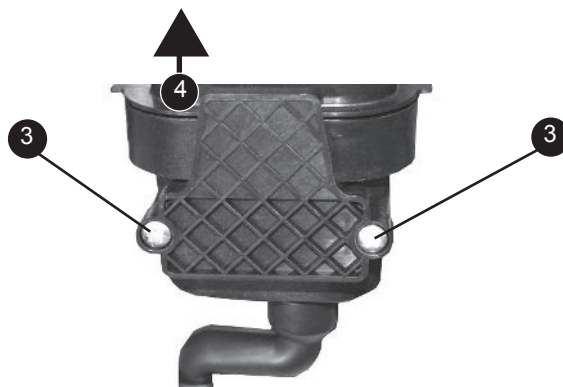

53 CONTROL THERMISTOR & RETURN THERMISTOR RENEWAL

1. Refer to Frame 49.
2. Unclip the control thermistor from the flow pipe and withdraw it from the boiler.
3. Unclip the return thermistor from the return pipe and withdraw it from the boiler.
4. Disconnect the electrical leads from the thermistors.
5. Reconnect the electrical leads to the new thermistors and reassemble in reverse order, ensuring that the thermistors are securely fitted to the pipes on the thermistor locator tabs as shown.
6. Check the operation of the boiler. Refer to Frames 37-40.

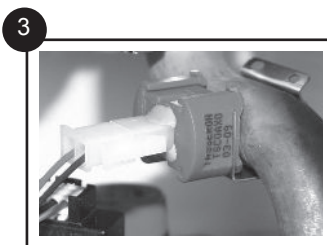
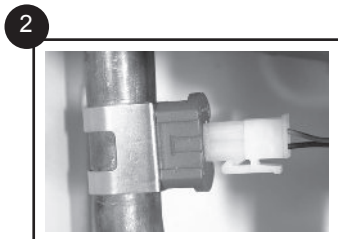
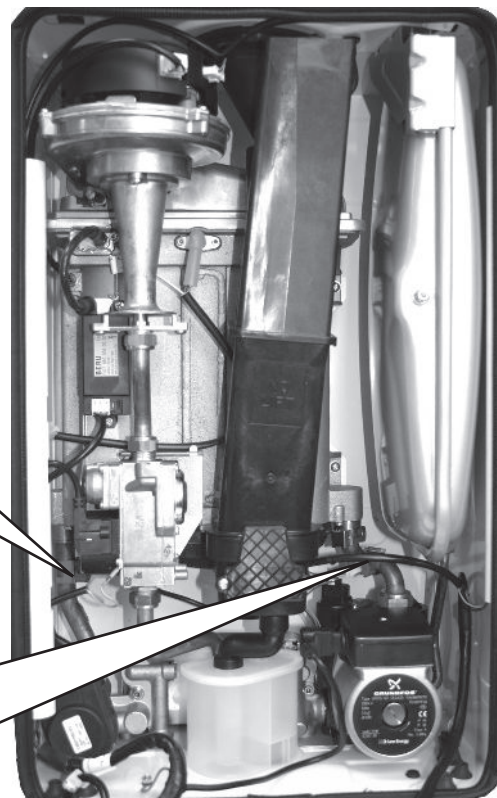

54 IGNITION ELECTRODE REPLACEMENT

1. Refer to Frame 49.
2. Remove the burner. Refer to Frame 52.
3. Unplug the ignition lead from the electrode.
4. Remove the earth lead from the ignition electrode.
5. Remove the 2 screws holding the ignition electrode to the combustion chamber.
6. Remove the electrode.
7. Fit the new ignition electrode, using the new gasket supplied. Check dimensions as shown.
8. Reassemble in reverse order.
9. Check the operation of the boiler. Refer to Frames 37-40.

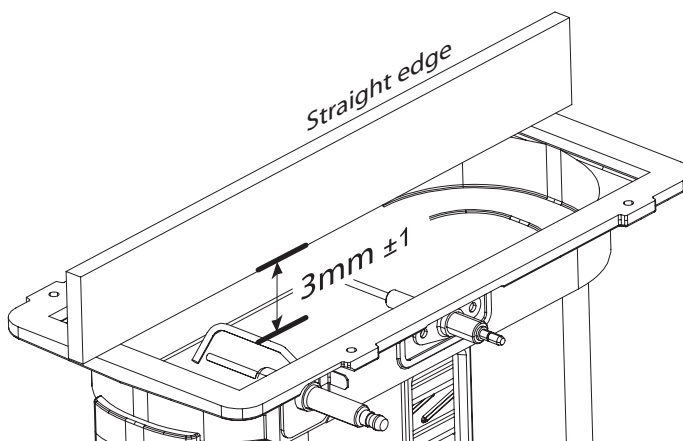
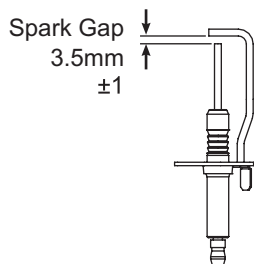
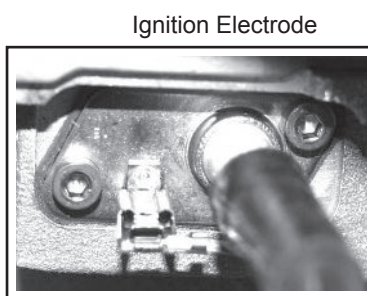
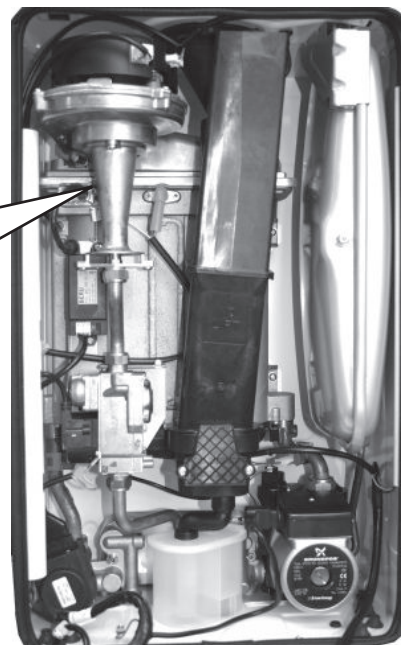

55 FLAME DETECTION ELECTRODE REPLACEMENT

1. Refer to Frame 49.
2. Remove the burner. Refer to Frame 52.
3. Unplug the flame detection lead from the electrode.
4. Remove the 2 screws retaining the detection electrode.
5. Remove the electrode.
6. Fit the new flame detection electrode, using the new gasket supplied.
7. Reassemble in reverse order.
8. Check the operation of the boiler. Refer to Frames 37-40.

Flame Detection Electrode

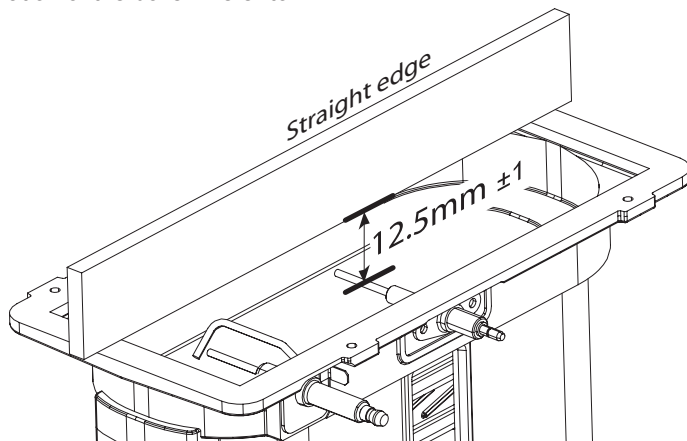
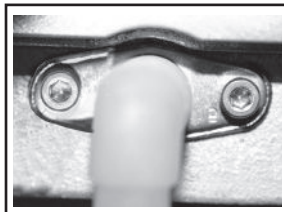

56 SPARK GENERATOR REPLACEMENT

1. Refer to Frame 49.
2. Disconnect the leads from the spark generator.
3. Remove the M5 screws securing the spark generator to the boiler chassis.
4. Fit the new spark generator and reassemble in reverse order ensuring the two earth leads are correctly replaced.
5. Check operation of the boiler. Refer to Frames 37-40.

Spark Generator

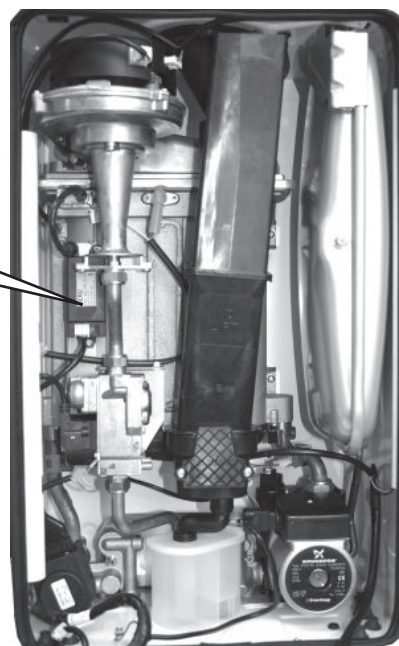
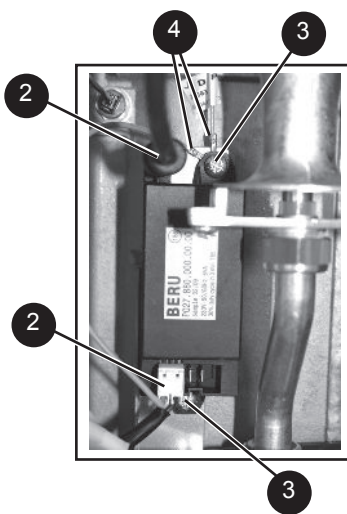

57 GAS CONTROL VALVE REPLACEMENT

1. Refer to Frame 49.
2. Unplug the electrical plug connection from the gas control valve and disconnect the earth wire.
3. Undo the union nut on the outlet of the gas control valve.
4. Undo the gas inlet pipe union at the inlet to the gas control valve.
5. Loosen the back nut retaining the valve to the bracket and withdraw the valve forwards.
6. Fit the new gas control valve ensuring the two sealing washers are in place and reconnect gas and electrical connections.
7. Check operation of the boiler. Refer to Frames 37-40.

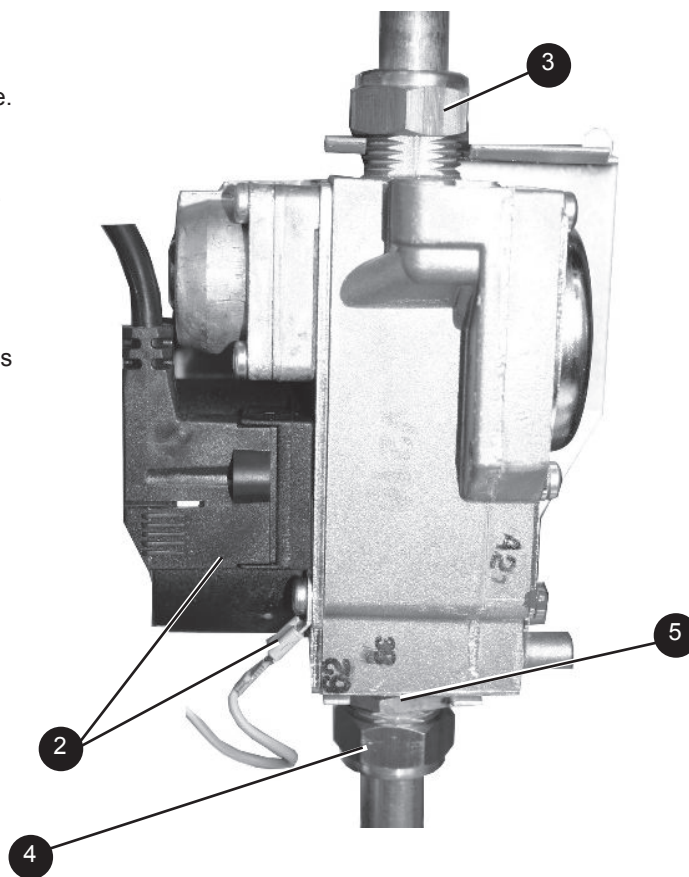

58 DIVERTER VALVE ACTUATOR REPLACEMENT

1. Refer to Frame 49.
2. Remove the electrical plug.
3. Using a suitable tool pull out the retaining clip and lift the diverter head from the brass body.
4. Fit new actuator head and reassemble in reverse order.
6. Check operation of the boiler. Refer to Frames 37-40.

Diverter Valve Actuator

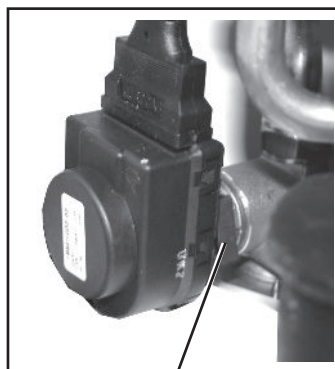

Retaining Clip



59 CONDENSATE TRAP/SIPHON REPLACEMENT

1. Refer to Frame 49.

Note: Ensure condensate trap is fully drained before removal.

2. Pull off the rubber pipe at the sump drain.

3. Disconnect the condensate drain pipe.

4. Remove the cleaning plug

5. Turn the siphon clockwise to disengage and lift to remove.

6. Reassemble in reverse order.

7. When reassembling ensure the trap is full of water.

8. Check operation of the boiler. Refer to Frames 37-40.

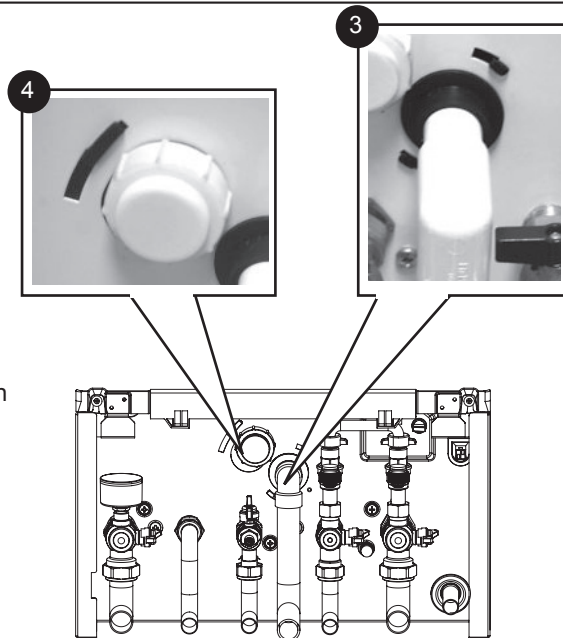
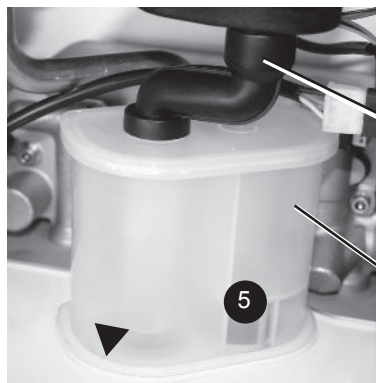

309690

60 MAIN PCB REPLACEMENT

Note that production boiler PCBs are factory pre-set to operate for boiler range and output, but when ordering Primary PCB as a spare, an additional Boiler Chip Card (BCC) MUST also be purchased for your specific boiler range and output.

Note. Fit the earth strap provided with the PCB to your wrist and secure to a suitable earth on the boiler chassis.

1. Refer to Frame 49.

2. Note the control knob positions.

3. Remove the 2 screws retaining the control box cover.

4. Carefully lift the 4 retaining clips and remove control box cover.

5. Unplug all lead connections to the PCB including the ribbon cable (to facilitate ribbon cable removal, ease side clips apart and pull upwards), also where applicable, push the small plastic clip with an electrical screwdriver to facilitate plug removal.

6. Spring out the two side retaining clips and pull the PCB upwards to clear the 4 corner retaining posts.

7. Take the new Primary PCB and attach the appropriate Boiler Chip Card (BCC) to it (this should correspond to the output of the boiler: 24kW, 30kW or 35kW).

Note. Ensure the correct orientation of BCC by placing "TOP" side up as shown.

8. Re-connect all plug connections.

9. Reassemble in reverse order.

10. Turn power back on to the boiler, after a few moments the display will start alternating between "c" and "0". Turn the reset knob fully clockwise and when the display shows "-" turn the knob fully anti-clockwise IMMEDIATELY.

Finally move the knob into the required position (Standby, Summer or Winter).

11. Check operation of the boiler. Refer to Frames 37-40.

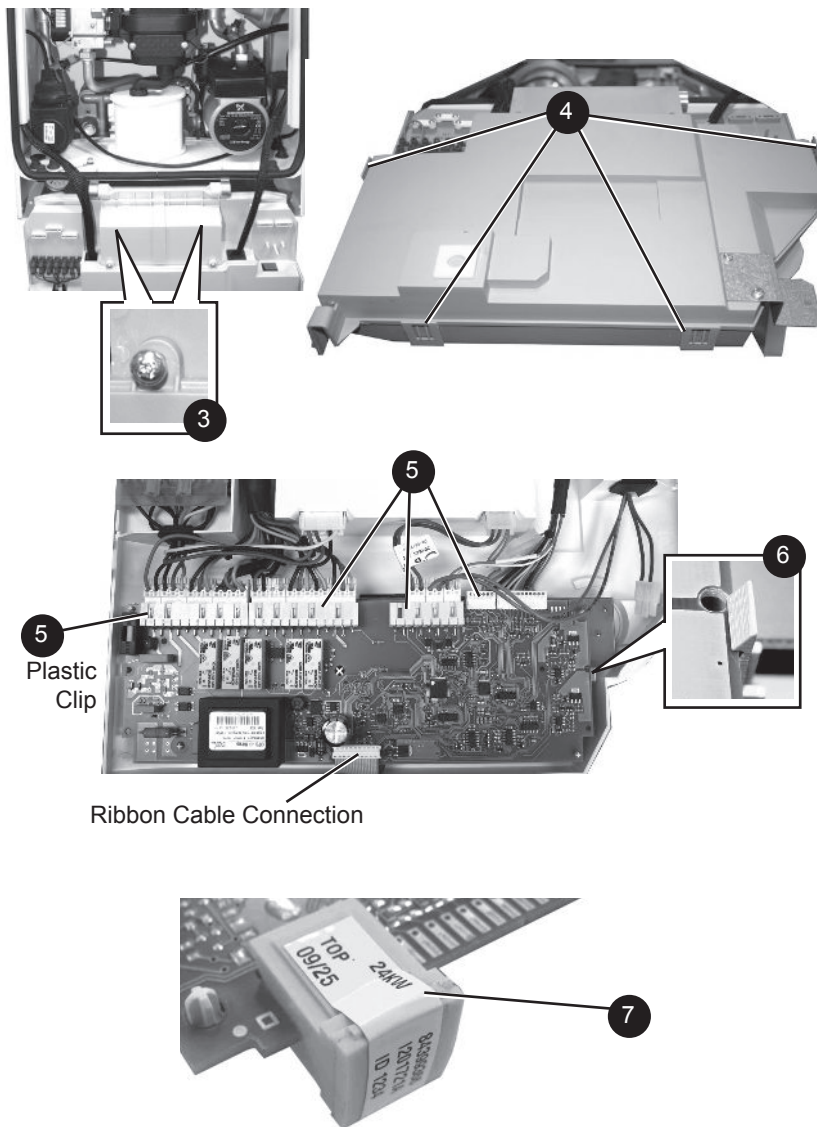

61 USER CONTROL PCB REPLACEMENT

Note. Fit the earth strap provided with the PCB to your wrist and a suitable earth on the boiler chassis.

1. Refer to Frame 49.
2. Remove the main PCB, refer to Frame 60.
3. Unclip the PCB and lift to clear the mounting posts.
4. Fit the new PCB ensuring the 4 potentiometer spindles line up with the control knobs which must be in a vertical position.
5. Reassemble in reverse order.
6. Check operation of the boiler. Refer to Frames 37-40.

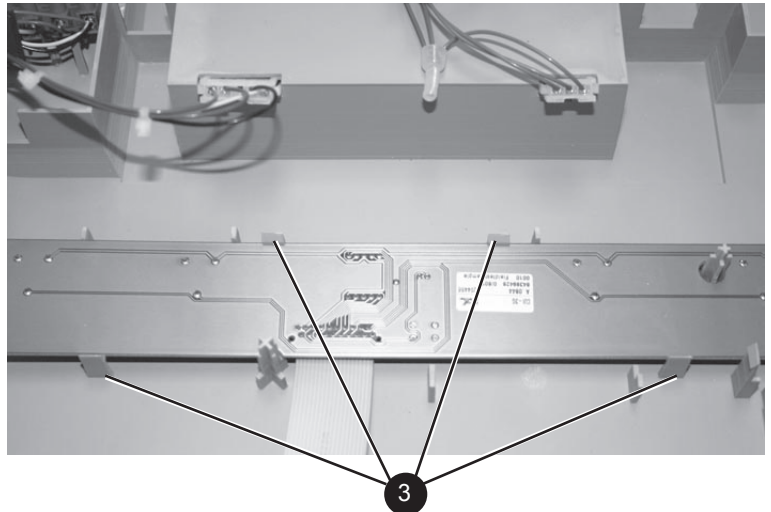

4

PCB

Control Knobs (to be in vertical position)

Potentiometer spindle

62 DHW FLOW TURBINE SENSOR REPLACEMENT

1. Refer to Frame 49.
2. Remove condensate trap/siphon. Refer to Frame 59.
3. Lift off the flow turbine sensor plastic retaining clip.
4. Unplug the electrical connection and transfer to new turbine sensor.
5. Reassemble in reverse order.
6. Check operation of the boiler. Refer to Frames 37-40.

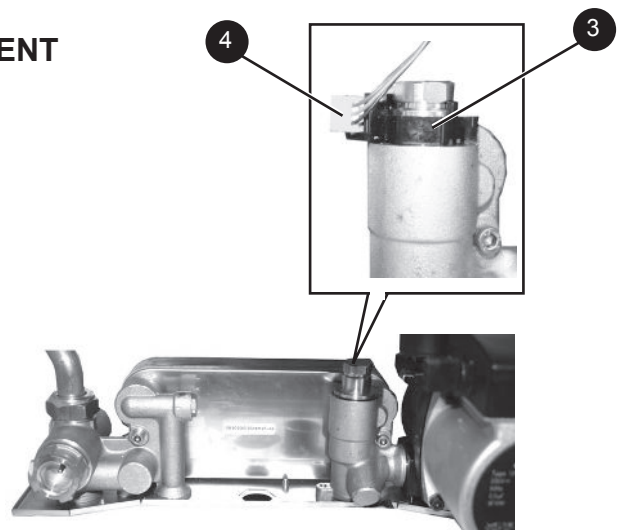

63 DRAINING THE BOILER

CENTRAL HEATING CIRCUIT

1. Refer to Frame 49.
2. Close all the CH water isolating valves on the boiler inlet.
3. To drain the primary heat exchanger circuit: Open the drain valve and attach a length of hose to the CH drain point.
4. After replacing any component on the boiler, remove the hose, close the drain valve and open all system isolating valves (re-pressurise as appropriate by re-connecting the filling loop, refer to Frame 29) before proceeding to check operation of the boiler.
5. Disconnect filling loop. Refer to Frame 29.
6. Check operation of the boiler. Refer to Frames 37-40.

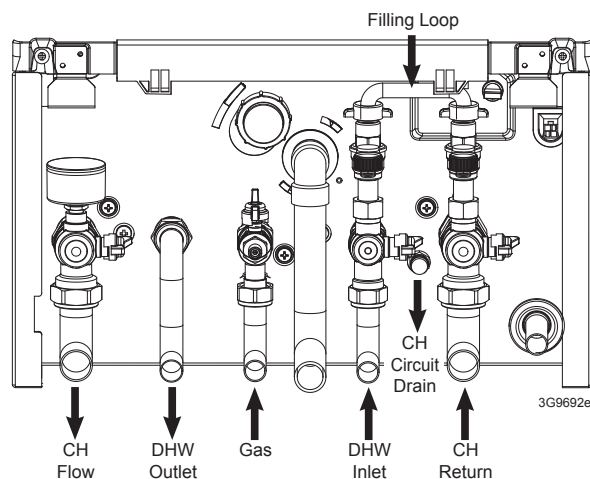

DOMESTIC HOT WATER CIRCUIT

1. Refer to Frame 50.
2. Close all the DHW water isolating valves on the boiler inlet.
3. To drain the domestic hot water circuit: As there is no direct drain for the domestic hot water circuit, depending on the location of the boiler, opening the lowest hot water tap may drain this circuit. However it must be noted that some residual water will be experienced during replacement of components.
4. After replacing any component on the boiler, close tap, close the drain valve and open all system isolating valves (re-pressurise as appropriate by re-connecting the filling loop, refer to Frame 33) before proceeding to check operation of the boiler.
5. Disconnect filling loop. Refer to Frame 29.
6. Check operation of the boiler. Refer to Frames 37-40.

64 PRESSURE GAUGE RENEWAL

1. Refer to Frame 49.
2. Drain the heating system. Refer to Frame 63.
3. Unscrew the pressure gauge and discard.
4. Fit new pressure gauge, using suitable jointing compound.
5. Refill the boiler. Refer to Frame 29.
6. Check operation of the boiler. Refer to Frames 37-40.

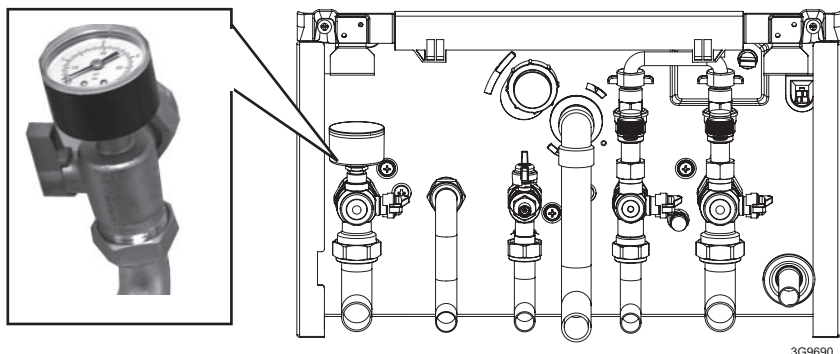

65 SAFETY RELIEF VALVE RENEWAL

1. Refer to Frame 49.
2. Drain the boiler. Refer to Frame 63.
3. Remove the condensate trap/siphon. Refer to Frame 59.
4. Remove expansion vessel. Refer to Frame 75.
5. Disconnect the electrical connection from the return thermistor.
6. Disconnect the 22mm pipe connection at the rear of the pump outlet.
7. Pull off the clip retaining the pipe to the heat exchanger swing the pipe to clear the pump and remove pipe.
8. Undo the safety valve union connection.
9. Withdraw the clip securing the safety valve.
10. Lift safety valve from boiler.
11. Fit the new safety valve and reassemble in reverse order ensuring the new 'o' ring is fitted to the top of the return pipe.
12. Refill boiler. Refer to Frame 29. Check operation of boiler. Refer to Frames 37-40.

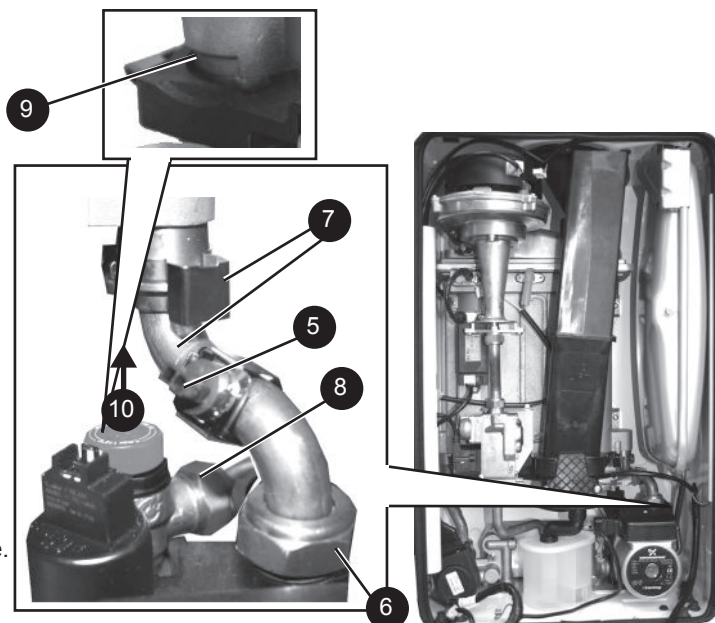

66 PUMP AUTOMATIC AIR VENT REPLACEMENT

1. Refer to Frame 49.
2. Drain the boiler. Refer to frame 63.
3. Remove the expansion vessel. Refer to Frame 75.
4. Firstly, increase access area by disconnecting the 22mm pipe connection at top of pump chamber and bottom of heat exchanger and remove pipe Refer to Frame 65 (no's 5,6 & 7).
5. The automatic air vent head is retained in the pump body with a bayonet connection. The air vent head and float assembly is removed by turning the head anti-clockwise (viewed from above) and pulling upwards.
6. Reassembly is the reverse of the above. Ensure the air vent head 'o' ring seal is in place when refitting and the new 'o' ring is fitted to the return pipe top connection.
7. Ensure the air vent cap is loose.
8. Refill the boiler. Refer to Frame 29. Check for leaks around the new air vent joint.
9. Check the operation of the boiler. Refer to Frames 37-40.

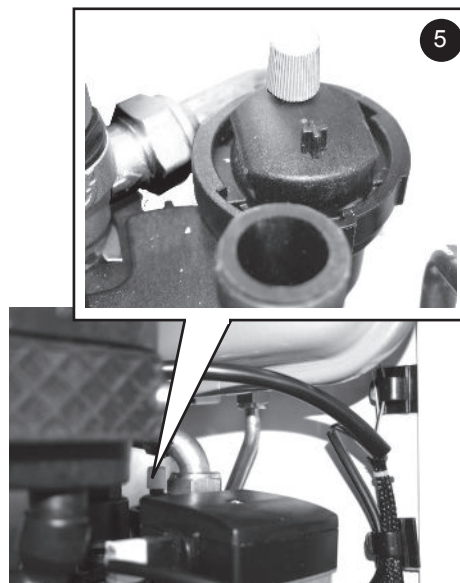

67 DHW FLOW TURBINE CARTRIDGE REPLACEMENT

1. Refer to Frame 49.
2. Drain the boiler. Refer to Frame 63.
3. Remove condensate trap/siphon. Refer to Frame 59.
4. Remove the DHW flow turbine sensor. Refer to Frame 62.
5. Unscrew the top connection to access the internal part.
6. Fit the new turbine cartridge.
7. Refit the turbine flow sensor.
8. Reassemble in reverse order.
9. Refill the boiler. Refer to Frame 29.
10. Check operation of the boiler. Refer to Frames 37-40.

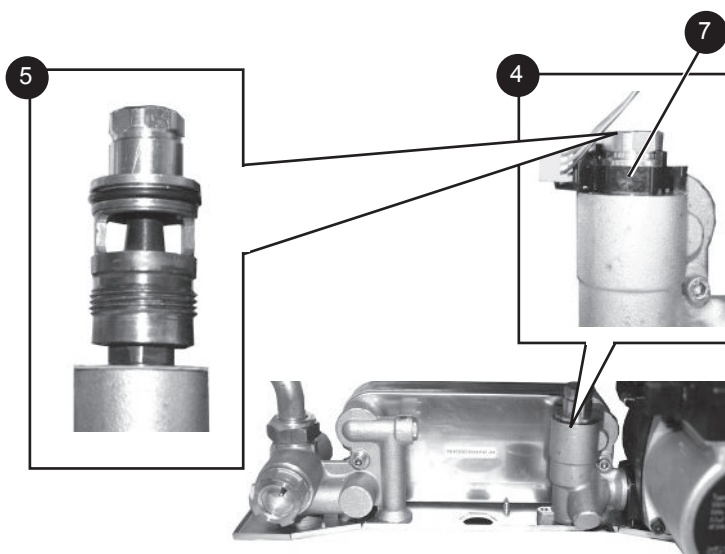

68 DIVERTER VALVE INTERNAL CARTRIDGE REPLACEMENT

FRONT CARTRIDGE REPLACEMENT

1. Refer to Frame 49.
2. Drain the boiler. Refer to Frame 63.
3. Remove the diverter valve head. Refer to Frame 58.
4. Unscrew the top connection to access the internal cartridge.
5. Fit the new valve mechanism ensuring the correct fit of the pin.
6. Reassemble in reverse order.
7. Refill the boiler. Refer to Frame 29.
8. Check operation of the boiler. Refer to Frames 37-40.

REAR CARTRIDGE REPLACEMENT

1. Refer to Frame 49.
2. Drain the boiler. Refer to Frame 63.
3. Remove the diverter valve head. Refer to Frame 58.
4. Remove the flow pipe. Refer to Frame 74 no. 12.
5. Disconnect the CH flow pipe and DHW outlet pipe union connections underneath the boiler. Refer to Frame 63.
6. Remove the plate heat exchanger LH fixing screw. Refer to Frame 69.
7. Remove the screw retaining the brass block to the bottom of the boiler casing and lift the brass block clear of the boiler.
8. Unscrew the rear cartridge connection.
9. Fit the new valve mechanism ensuring the correct fit of the pin.
10. Reassemble in reverse order.
11. Refill the boiler. Refer to Frame 29.
12. Check operation of the boiler. Refer to Frames 37-40.

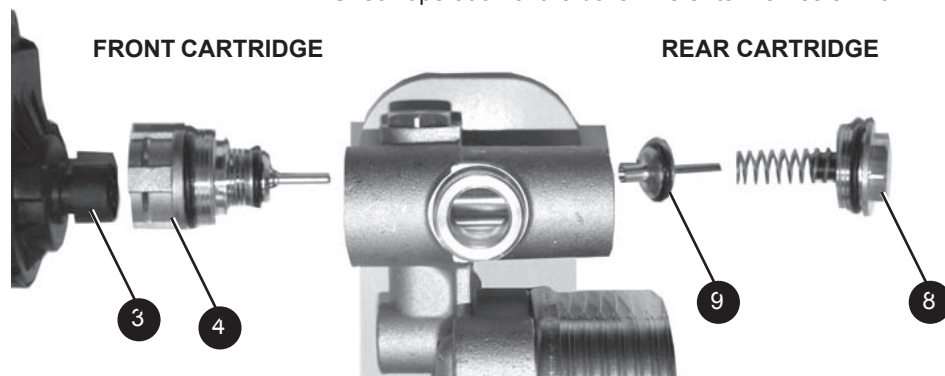

69 DHW PLATE HEAT EXCH. REPLACEMENT

1. Refer to Frame 49.
2. Drain the boiler. Refer to Frame 63.
3. Remove condensate trap/siphon. Refer to Frame 59.
4. Remove the diverter valve actuator. Refer to Frame 58.
5. Remove the 2 allen screws securing the plate heat exchanger to the brass housings.
6. Manoeuvre the plate heat exchanger out of the top LH or centre of the controls area.
7. Fit the new plate heat exchanger, using the new o-rings supplied.

Note. The mounting pins are offset so the correct position can be defined from the location of the holes on the brass mounting.

8. Reassemble in reverse order.
9. Refill the boiler. Refer to Frame 29.
10. Check operation of the boiler. Refer to Frames 37-40.

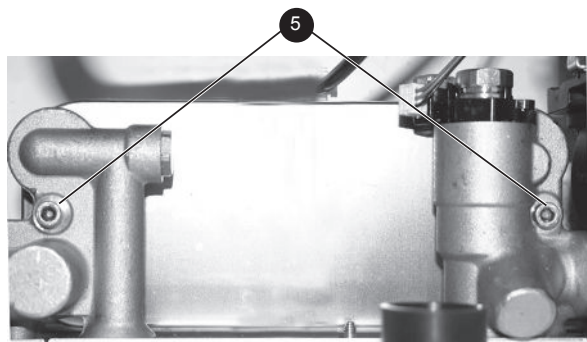

70 PUMP HEAD REPLACEMENT

1. Refer to Frame 49.
2. Drain the boiler. Refer to Frame 63.
3. Disconnect the electrical plug from the pump.
4. Remove the 4 Allen screws retaining the pump head.
5. Remove the pump head.
6. Fit the new pump head.
7. Reassemble in reverse order.
8. Refill the boiler. Refer to Frame 29.
9. Check operation of the boiler. Refer to Frames 37-40.

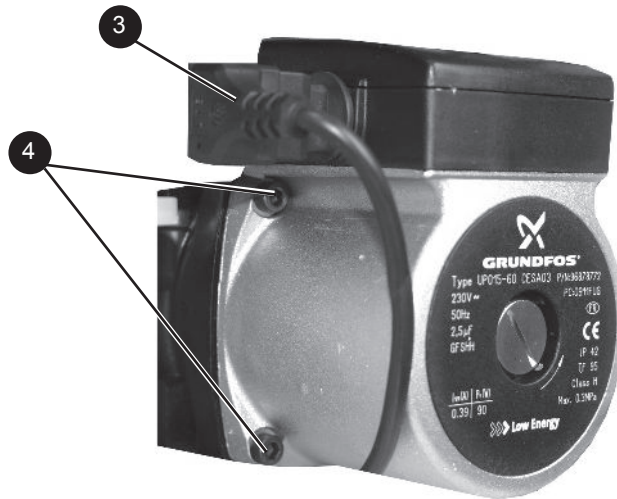

71 CH WATER PRESSURE SENSOR REPLACEMENT

1. Refer to Frame 49.
2. Drain the boiler. Refer to frame 63.
3. Remove condensate trap/siphon. Refer to Frame 59.
4. Using a suitable tool pull out the retaining clip.
5. Pull the pressure sensor upwards to remove.
6. Unplug the electrical connection and transfer to the new pressure sensor.
7. Push the new pressure sensor onto the rear pump housing and fit retaining clip.
8. Reassemble in reverse order.
9. Refill the boiler. Refer to Frame 29.
10. Check Operation of the boiler. Refer to Frames 37-40.

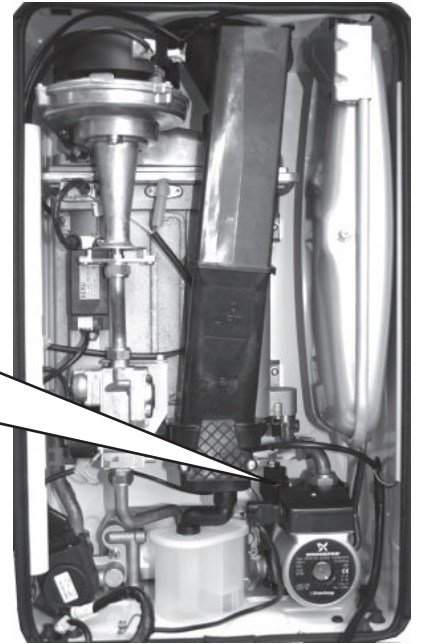
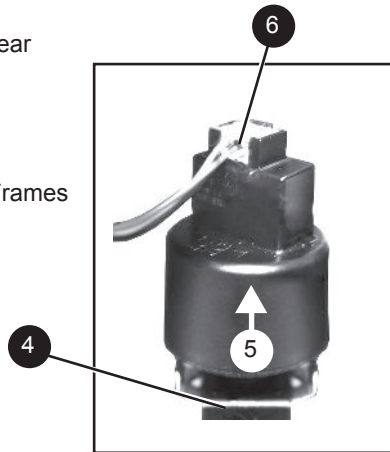

72 DHW FILTER & DHW FLOW REGULATOR CLEANING / REPLACEMENT

- | | |
|--|---|
| <ol style="list-style-type: none"> 1. Refer to Frame 49. 2. Isolate the mains cold water supply to the boiler. 3. Drain the boiler DHW circuit. Refer to frame 64. 4. Remove the DHW flow turbine cartridge. Refer to Frame 68. 5. Unscrew the flow regulator housing. 6. Remove the filter. 7. Clean or replace filter as necessary. 8. Reassemble in reverse order. 9. Refill the boiler. Refer to Frame 29. 10. Check Operation of the boiler. Refer to Frames 37-40. | <ol style="list-style-type: none"> 1. Refer to Frame 49. 2. Isolate the mains cold water supply to the boiler. 3. Drain the boiler DHW circuit. Refer to Frame 63. 4. Remove the DHW flow turbine cartridge. Refer to Frame 67. 5. Unscrew the flow regulator housing. 6. Inspect the flow regulator for any blockage and remove if necessary. 7. Reassemble in reverse order. 8. Refill the boiler. Refer to Frame 29. 9. Check Operation of the boiler. Refer to Frames 37-40. |
|--|---|

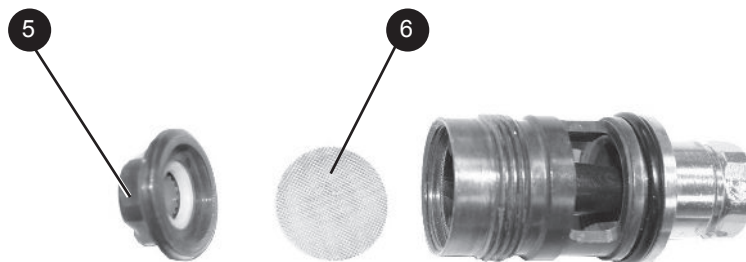

73 NO FLOW THERMISTOR REPLACEMENT

1. Refer to Frame 49.
2. Drain down the boiler. Refer to Frame 63.
3. Unplug the electrical lead.
4. Unscrew the thermistor (to facilitate removal a 13mm socket spanner should be used).
5. Fit the new thermistor using the sealing washer provided.
6. Reassemble in the reverse order.
7. Refill the boiler. Refer to Frame 29.
8. Check the operation of the boiler. Refer to Frames 37-40.

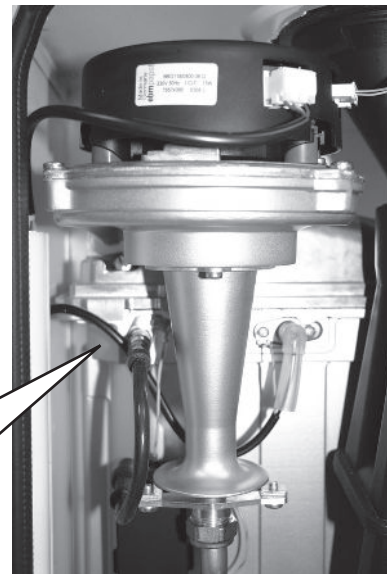
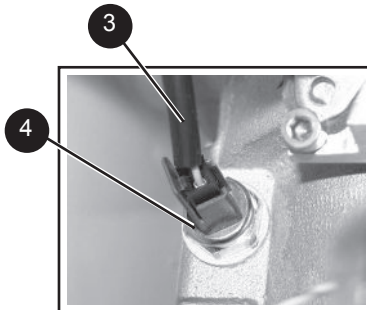

74 HEAT ENGINE RENEWAL

Refer also to Frame 6 - 'Boiler Exploded View'

IMPORTANT

Before starting the removal procedure, protect the gas and electrical controls with a waterproof sheet or plastic bag.

1. Refer to Frame 49.
2. Drain the boiler. Refer to Frame 63.
3. Remove the fan / venturi assembly and place on one side. Refer to frame 50.
4. Remove the burner and place on one side. Refer to Frame 52.
5. Remove the ignition and detection electrodes and divertor actuator head. Refer to Frames 54, 55 and 58.
6. Remove the spark generator. Refer to Frame 56.
7. Remove the gas valve. Refer to Frame 57.
8. Remove the expansion vessel. Refer to Frame 75.
9. Remove the no flow thermistor. Refer to Frame 73.
10. Remove the 2 M5 screws retaining the gas valve mounting bracket and transfer bracket to the new heat exchanger.
11. Undo the inlet pipe union nut and remove the retaining spring clip and remove pipe.
12. Undo the flow pipe union nut and remove pipe.
13. Remove the condensate rubber pipe. Refer to Frame 59, no. 2.
14. Remove the two heat exchanger fixing screws.
15. Remove the Heat exchanger.
16. Reassemble in reverse order, ensuring the heat exchanger LH retaining bracket is correctly positioned. Replace any new 'o' rings supplied with new heat exchanger and replacing gaskets or seals if any sign of damage is evident. When replacing the spring clips located on both the flow and return pipe connections, ensure clip is oriented to correctly match connecting pipe diameters.

17. Ensure the trap/siphon is filled with water. Refer to Frame 59.
18. Refill the boiler. Refer to Frame 29.
19. Check operation of the boiler. Refer to Frames 37-40.

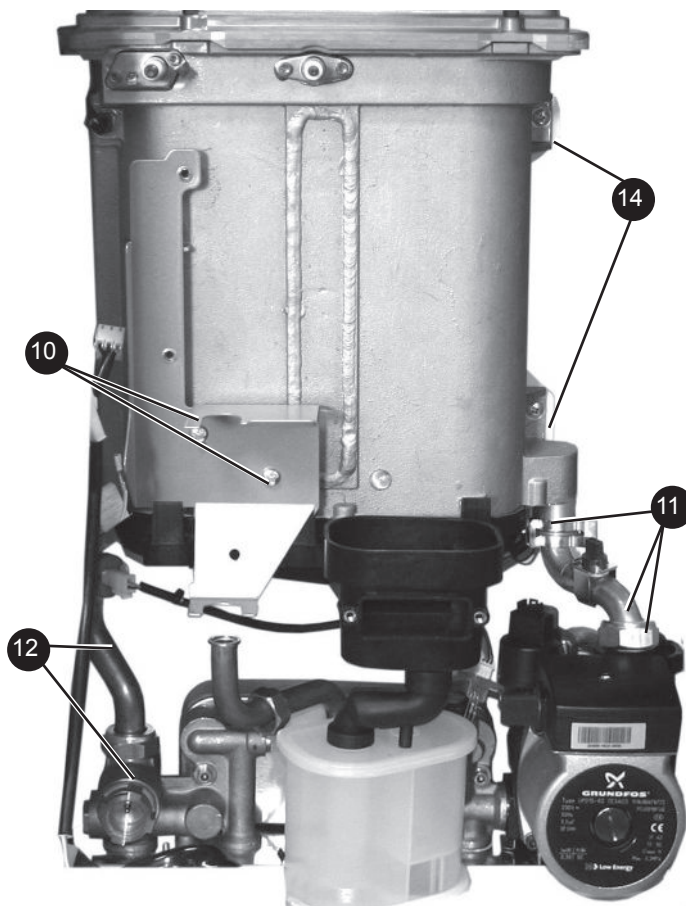

75 EXPANSION VESSEL RECHARGING & REPLACEMENT

RECHARGING

1. Refer to Frame 49.
2. Remove the charge point cover.
3. Recharge the tank pressure to 0.75 bar.
4. Re-assemble in reverse order
5. Check operation of the boiler. Refer to Frames 37-40.

REPLACEMENT

6. Refer to Frame 49.
7. Drain the boiler CH circuit. Refer to Frame 63.
8. Unscrew the union nut on the vessel water connection pipe.
9. Support the expansion vessel and unscrew the 2 screws from the securing clamp, located on the top of the boiler, and remove. (Note the position of the bracket on the vessel)
10. Remove the expansion vessel.
11. Fit the new expansion vessel.
12. Reassemble in reverse order.
13. Refill the boiler. Refer to Frame 29.
14. Check operation of the boiler. Refer to Frames 37-40.

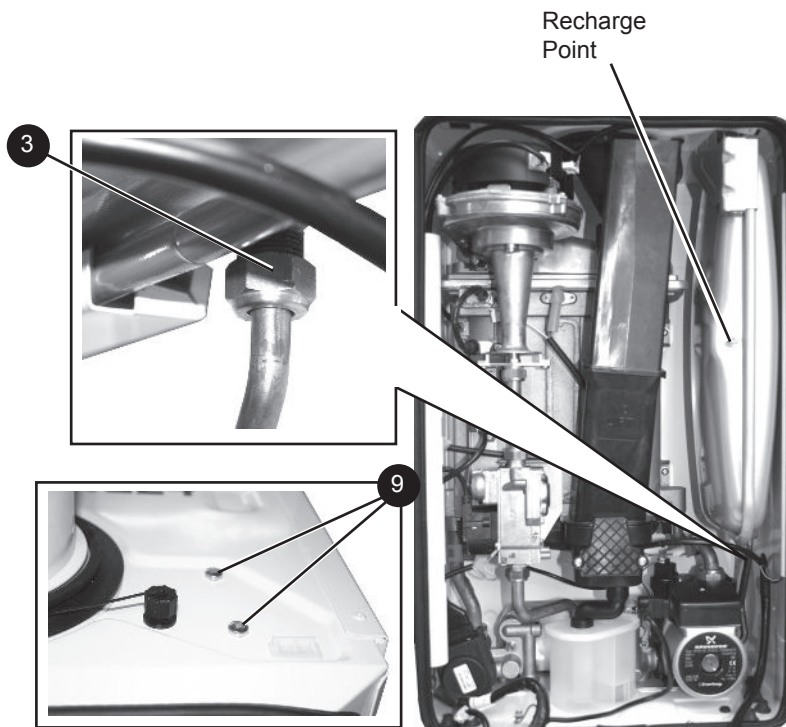

76 BOILER SEALING PANEL SEAL REPLACEMENT

1. Refer to Frame 49.
2. Remove the old seal from the casing and thoroughly clean the casing surfaces.
3. Fit the new seal, ensuring the bottom joint provides an air tight seal.
5. Reassemble in reverse order.
6. Check operation of the boiler. Refer to Frames 37-40.

Note. *Ensure that the boiler front panel is correctly sealed, compressing the seal to make an airtight joint.*

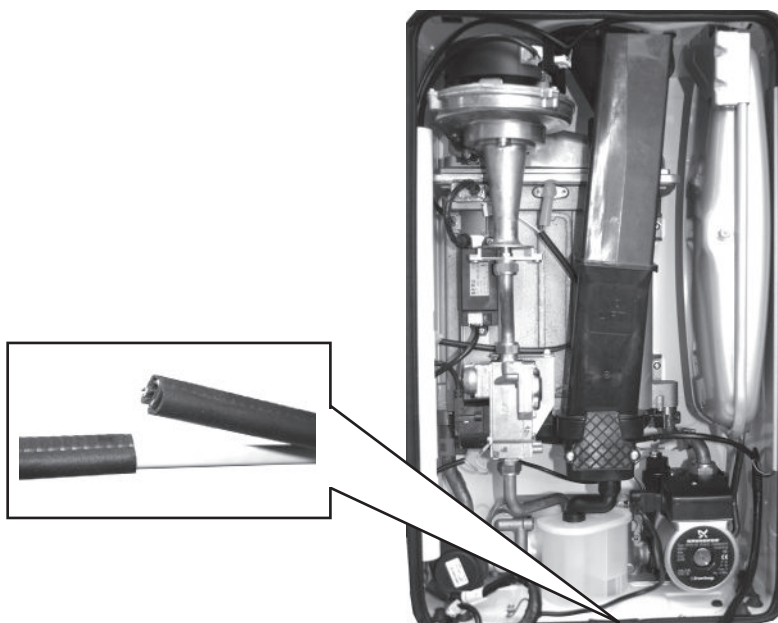

FAULT FINDING

77 FAULT FINDING CHART MAIN MENU

Note. Boiler status display information is shown in shaded boxes below. Up to six messages will be displayed in rotation.

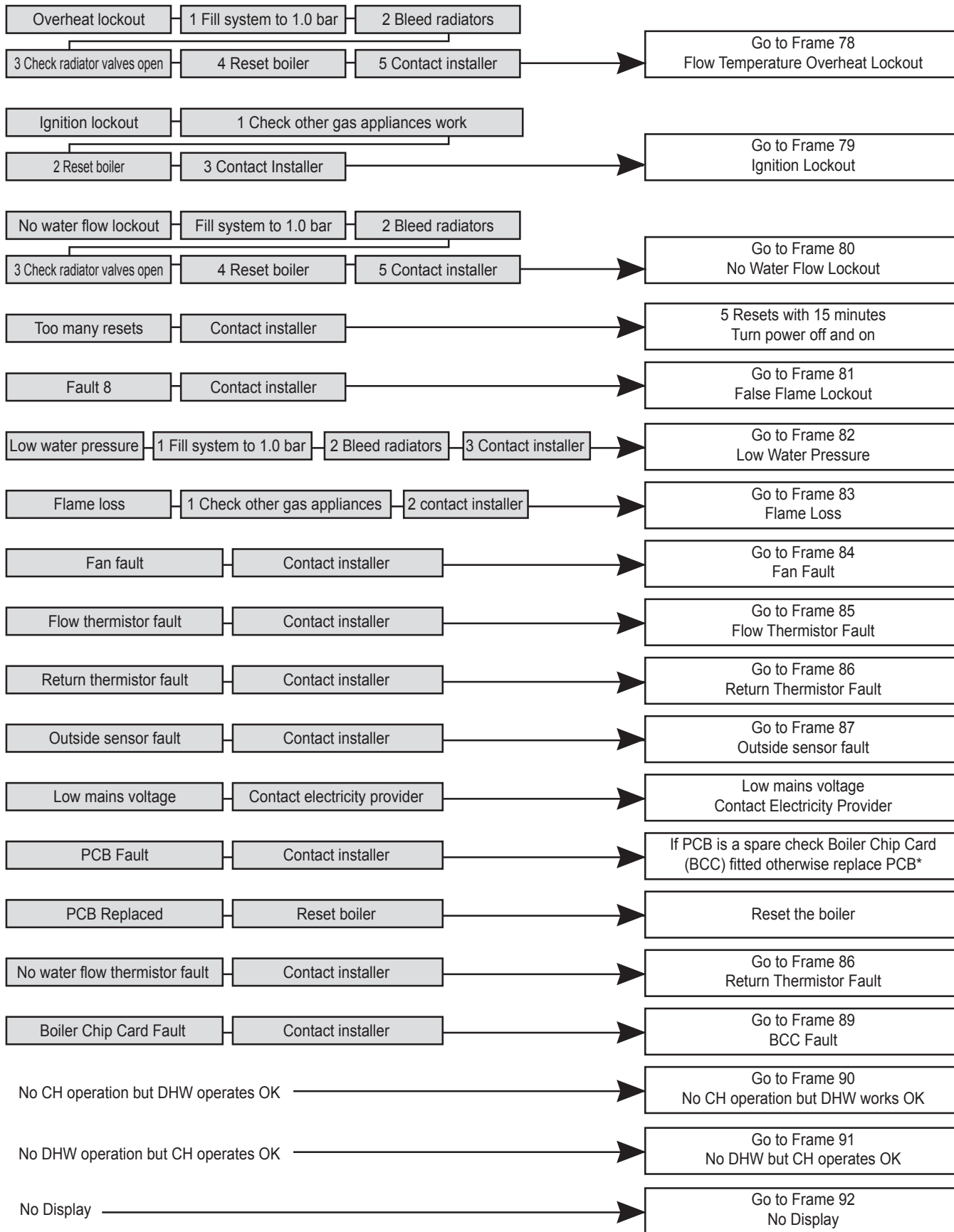

Note that production boiler PCBs are factory pre-set to operate for boiler range and output, but when ordering Primary PCB as a spare, an additional Boiler Chip Card (BCC) MUST also be purchased for your specific boiler range and output.

RESET PROCEDURE - To reset boiler, turn mode knob to reset position and immediately turn knob back to required setting.

FAULT FINDING

78 OVERHEAT LOCKOUT - 1 FILL SYSTEM TO 1.0 BAR - 2 BLEED RADIATORS - 3 CHECK RADIATOR VALVES OPEN - 4 RESET BOILER - 5 CONTACT INSTALLER

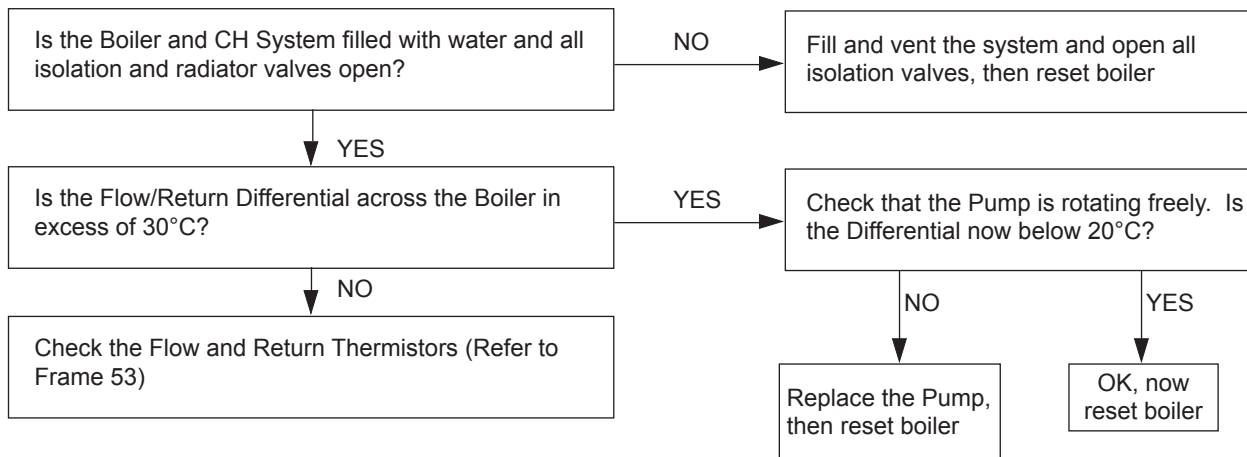

RESET PROCEDURE - To reset boiler, turn mode knob to reset position and immediately turn knob back to required setting.

79 IGNITION LOCKOUT - 1 CHECK OTHER GAS APPLIANCES WORK - 2 RESET BOILER - 3 CONTACT INSTALLER

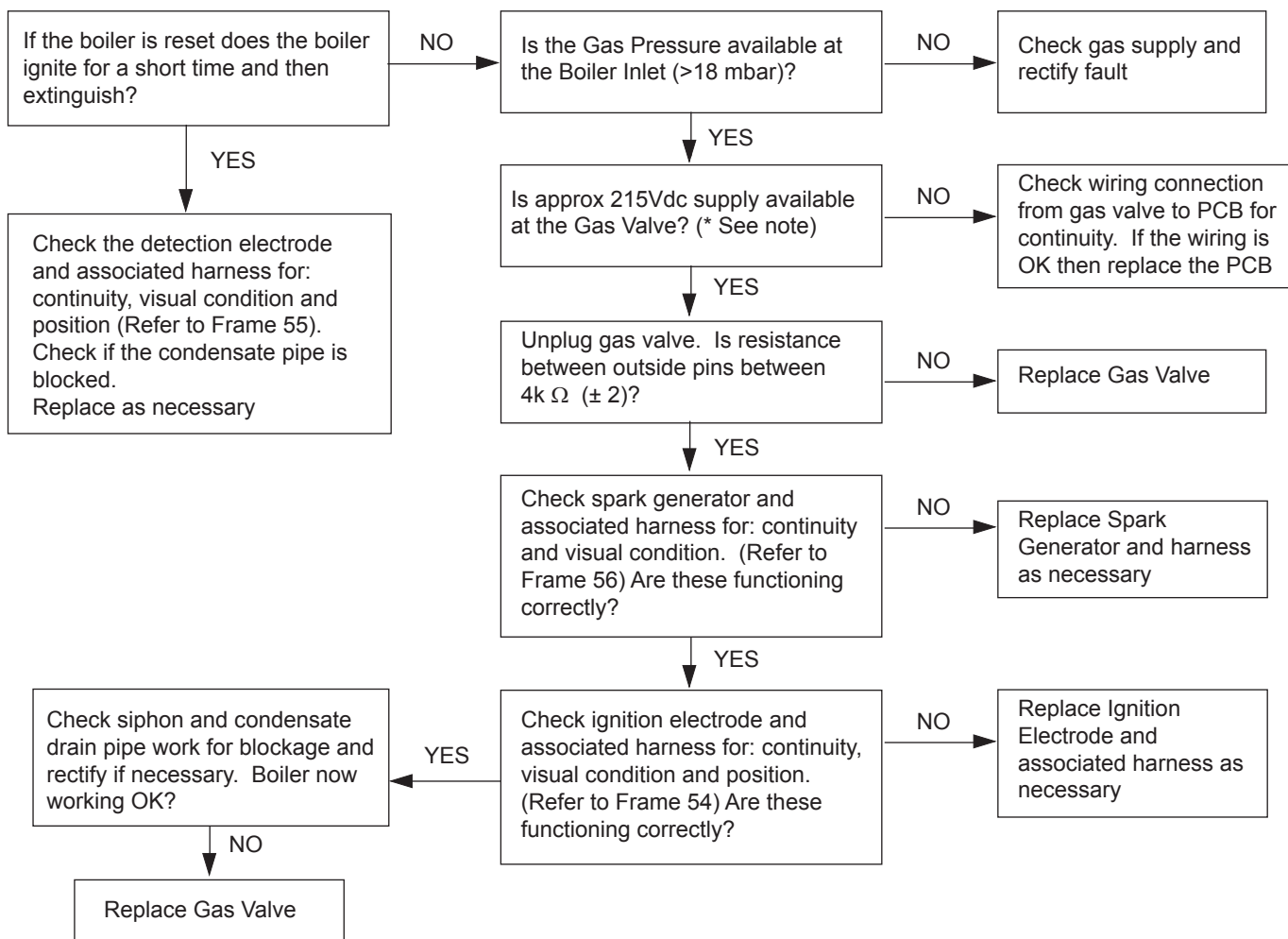

*** Note:** due to the wave form of the rectified voltage, the reading will vary depending on the type of meter used to measure the value. In general terms a reading greater than 150V indicates that the correct voltage is supplied to the gas valve.

RESET PROCEDURE - To reset boiler, turn mode knob to reset position and immediately turn knob back to required setting.

FAULT FINDING

80 NO WATER FLOW LOCKOUT - 1 FILL SYSTEM TO 1.0 BAR - 2 BLEED RADIATORS - 3 CHECK RADIATOR VALVES OPEN - 4 RESET BOILER - 5 CONTACT INSTALLER

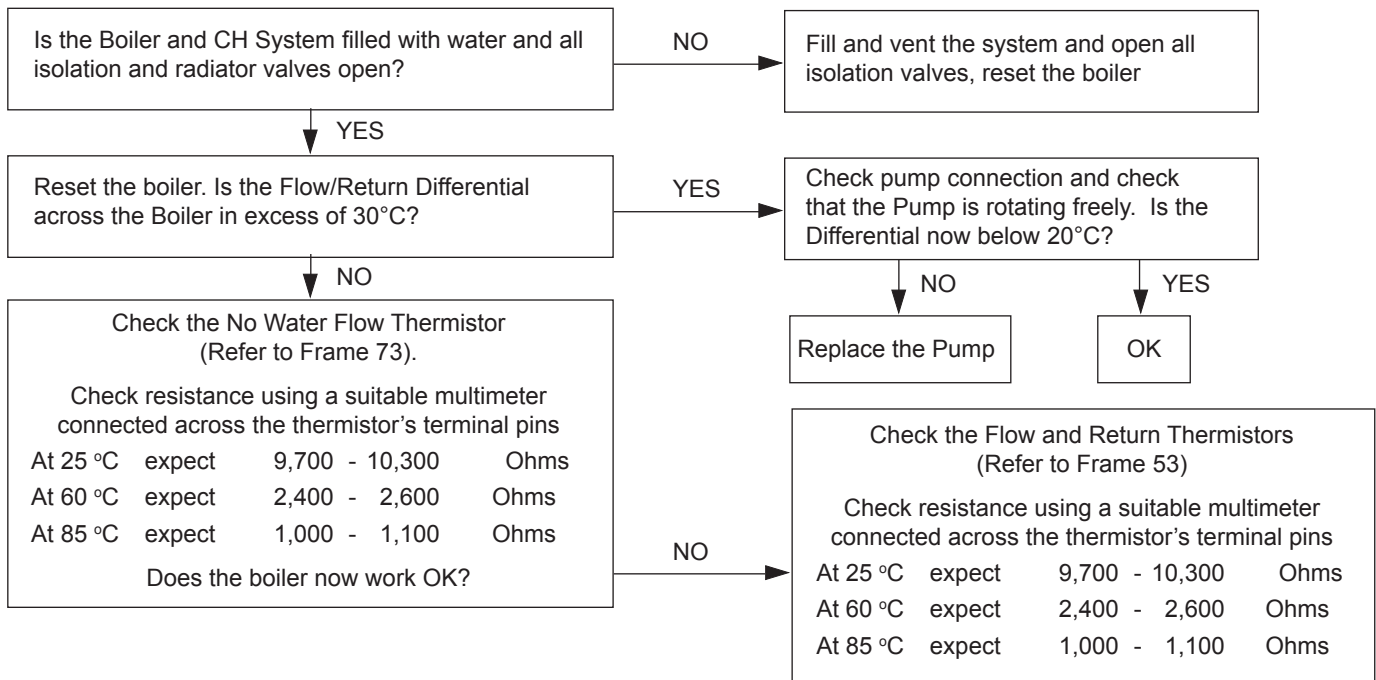

RESET PROCEDURE - To reset boiler, turn mode knob to reset position and immediately turn knob back to required setting.

81 FAULT 8 - CONTACT INSTALLER (FALSE FLAME LOCKOUT)

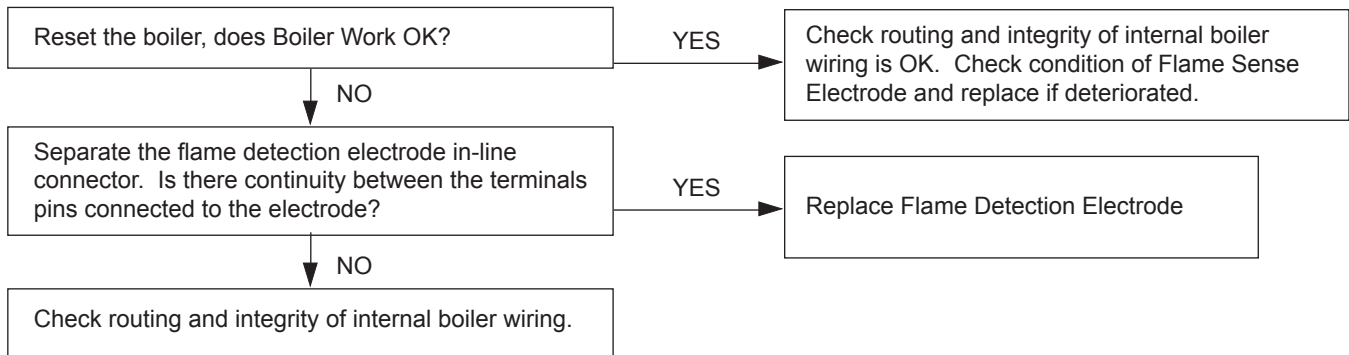

RESET PROCEDURE - To reset boiler, turn mode knob to reset position and immediately turn knob back to required setting.

82 LOW WATER PRESSURE - 1 FILL SYSTEM TO 1.0 BAR - 2 BLEED RADIATORS - 3 CONTACT INSTALLER

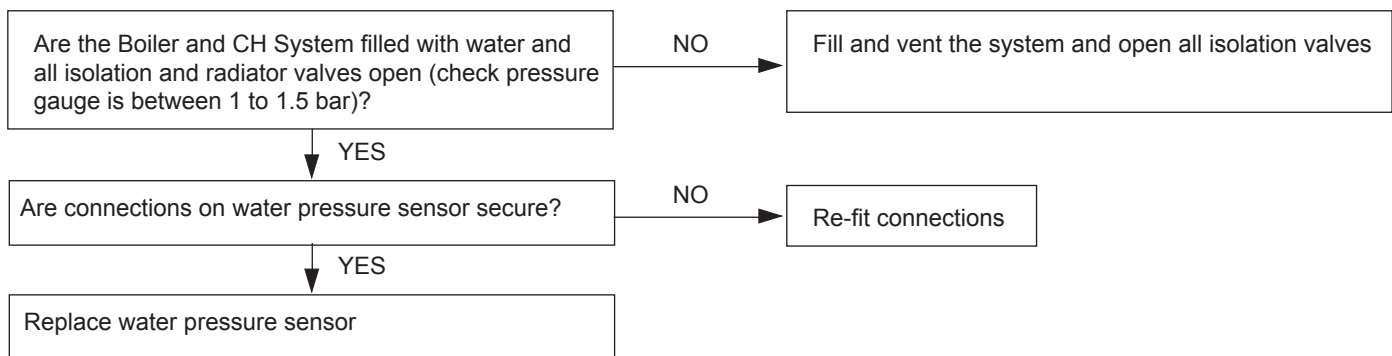

FAULT FINDING

83 FLAME LOSS - 1 CHECK OTHER GAS APPLIANCES WORK - 2 CONTACT INSTALLER

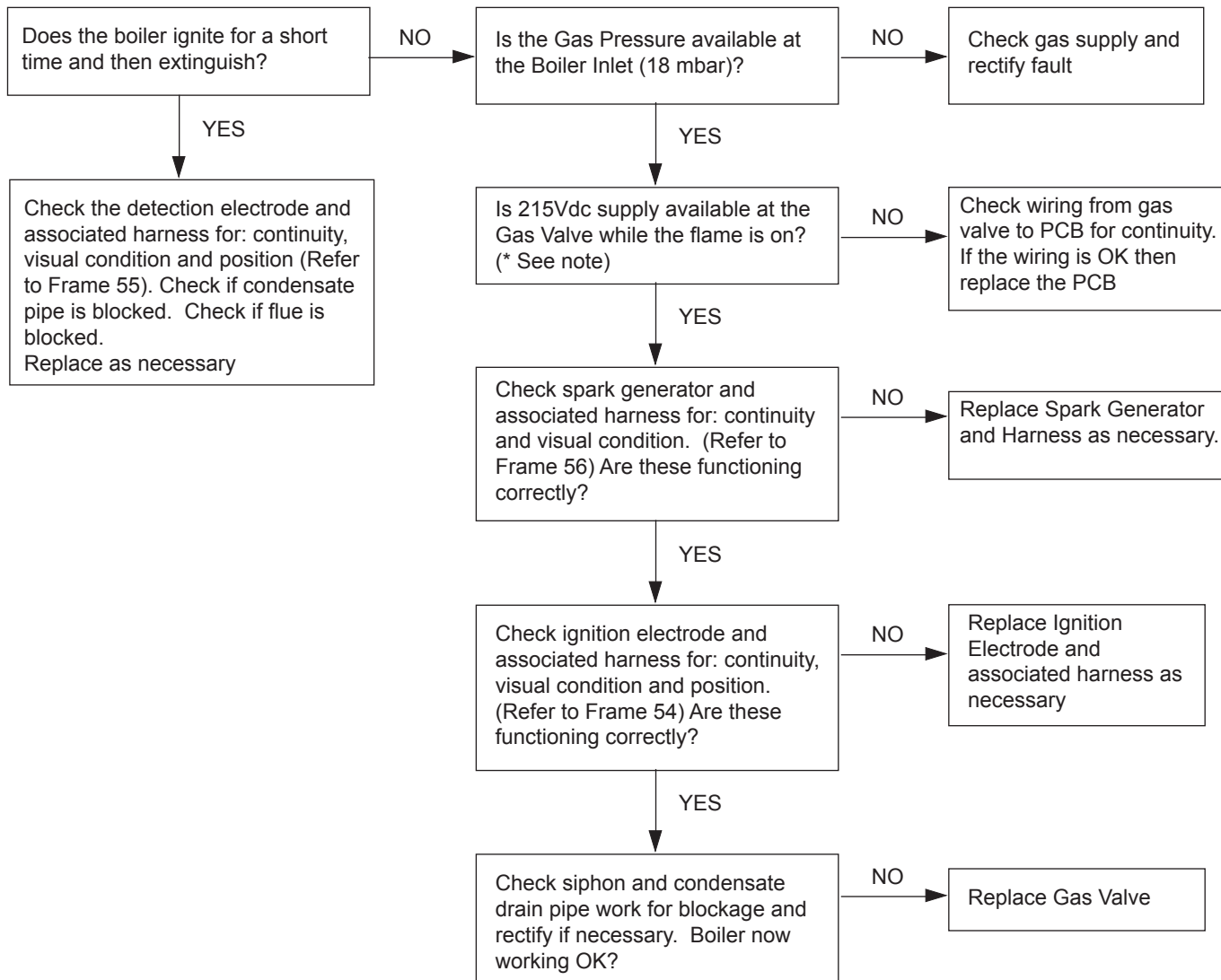

** Note: due to the wave form of the rectified voltage, the reading will vary depending on the type of meter used to measure the value. In general terms a reading greater than 150V indicates that the correct voltage is supplied to the gas valve.*

84 FAN FAULT - CONTACT INSTALLER

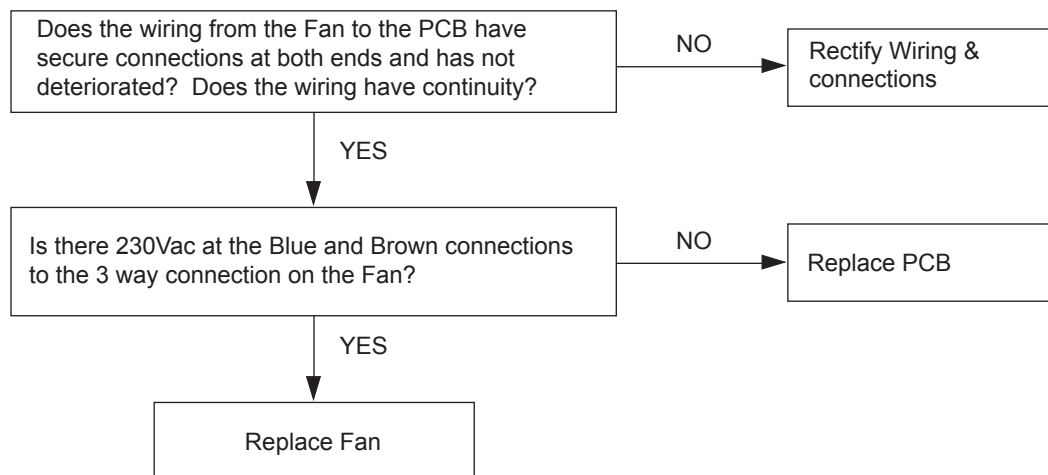

FAULT FINDING

85 FLOW THERMISTOR FAULT - CONTACT INSTALLER

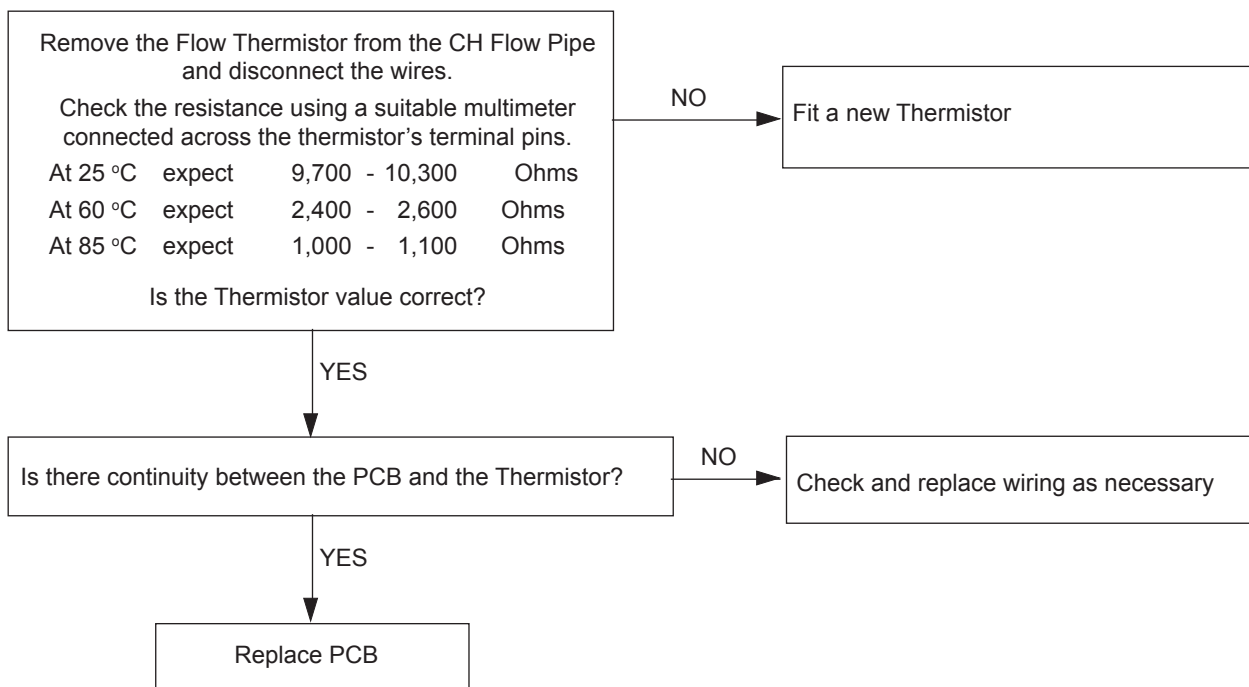

86 RETURN THERMISTOR FAULT - CONTACT INSTALLER

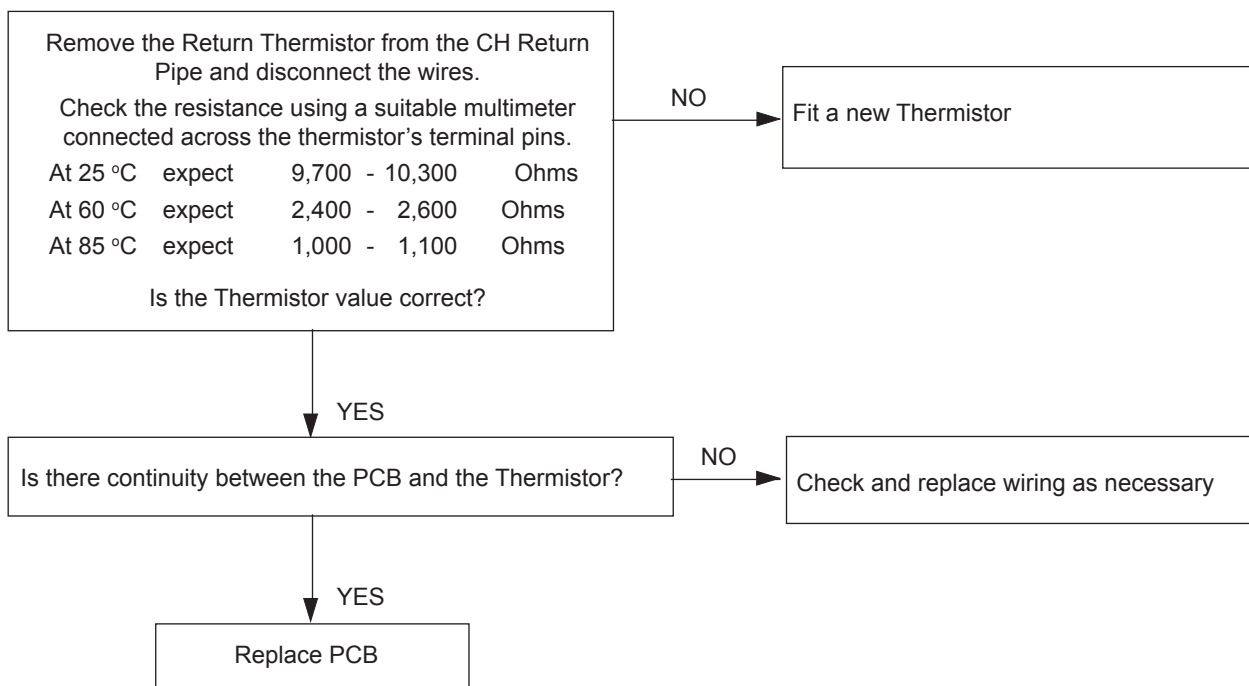

FAULT FINDING

87 OUTSIDE SENSOR FAULT - CONTACT INSTALLER

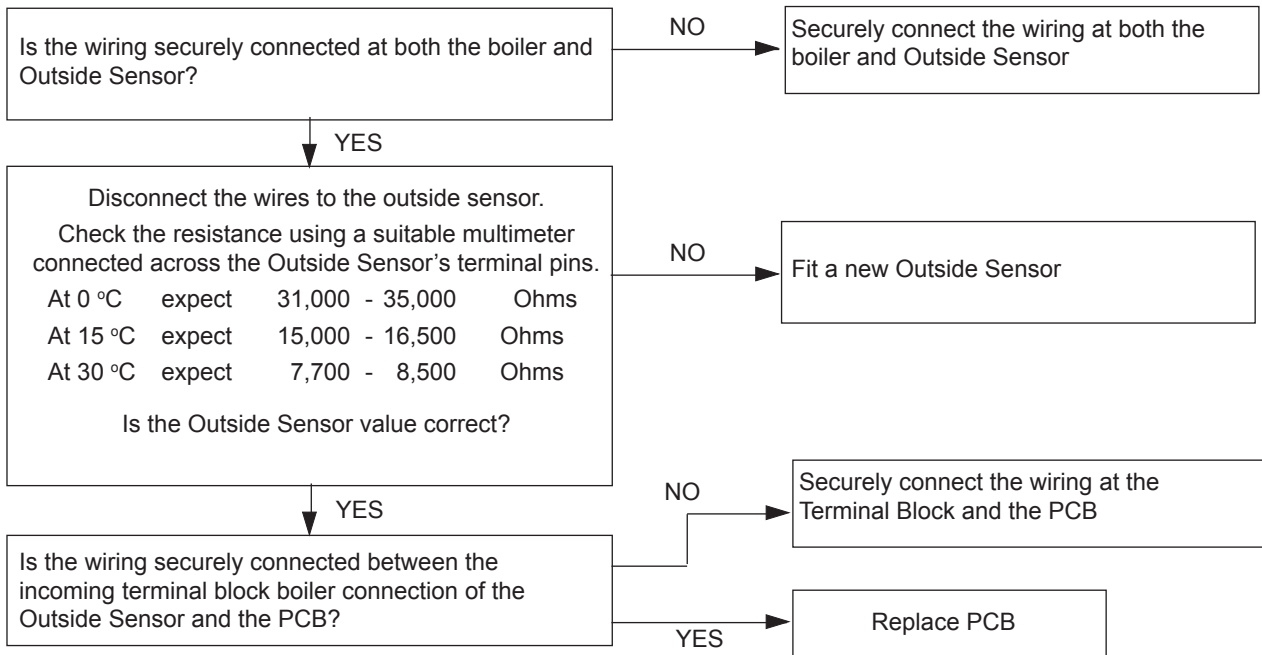

88 NO WATER FLOW THERMISTOR FAULT - CONTACT INSTALLER

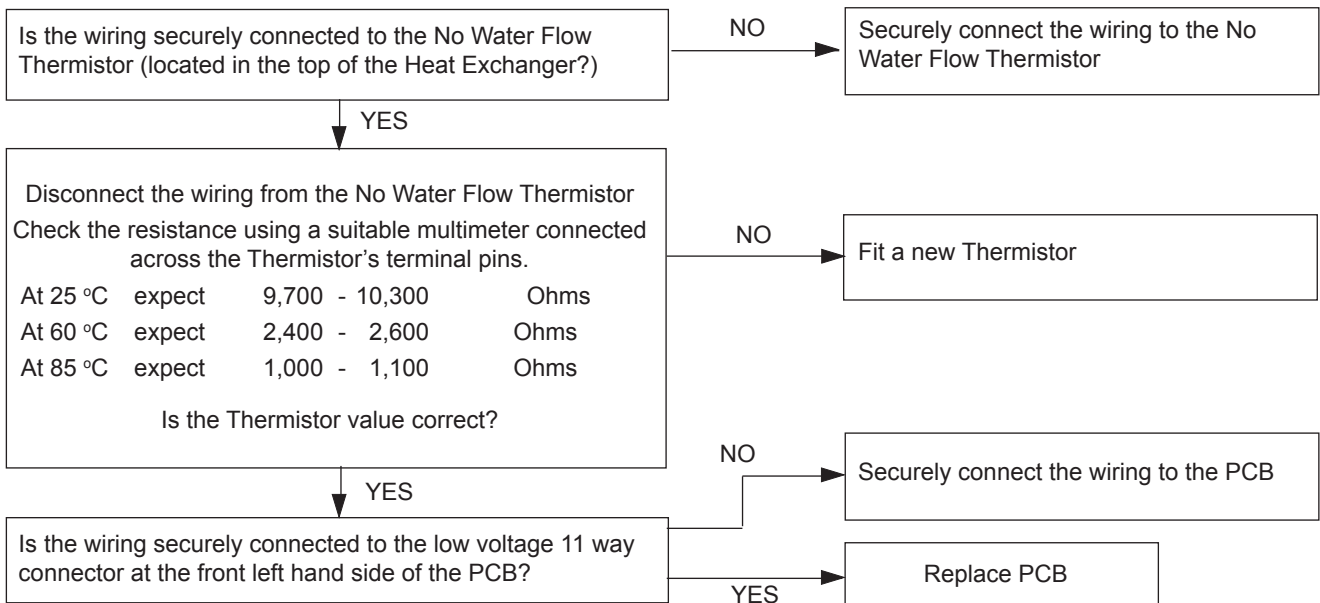

FAULT FINDING

91 NO HW BUT CH ON

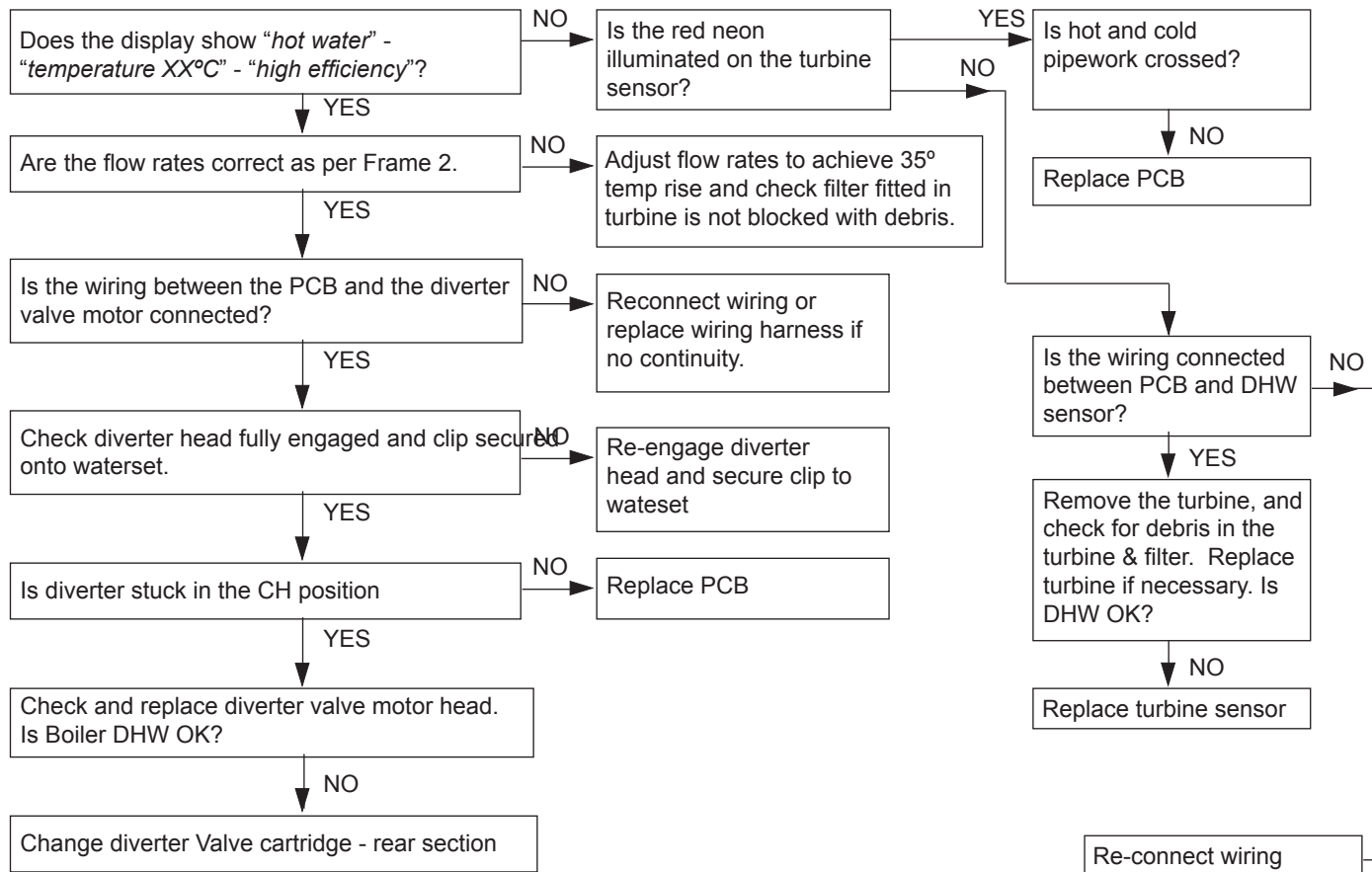

92 NO DISPLAY

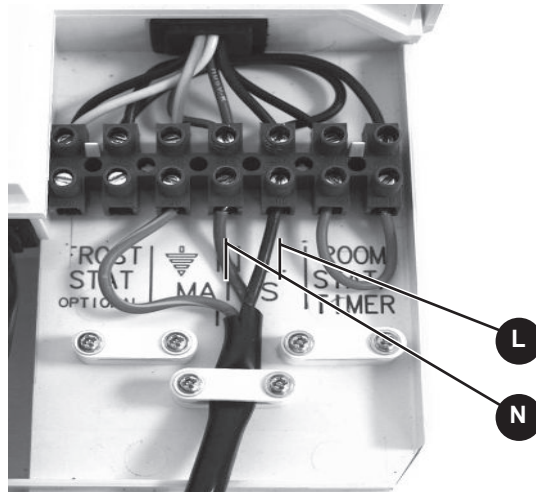
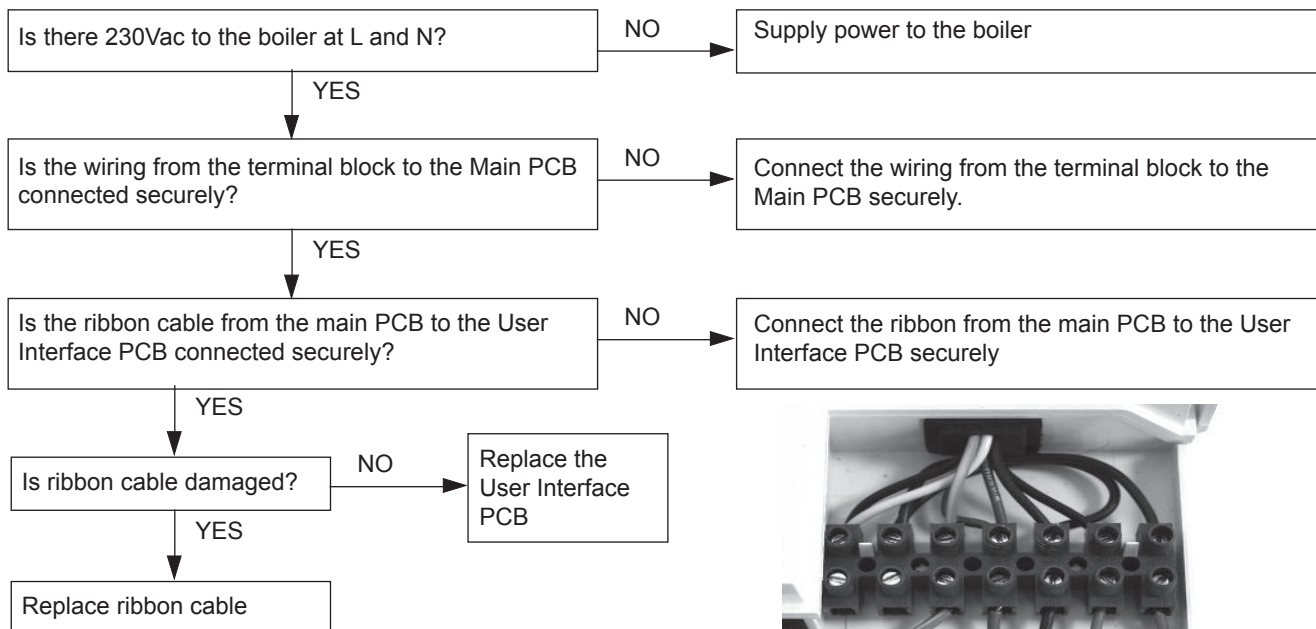

FAULT FINDING FAULT FINDING FAULT FINDING FAULT FINDING

SHORT LIST OF PARTS

The following are parts commonly required due to damage or expendability. Their failure or absence is likely to affect safety or performance of this appliance.

The list is extracted from the British Gas List of Parts, which contains all available spare parts.

The full list is held by British Gas Services, Ideal Stelrad Group distributors and merchants.

When ordering spares please quote:

1. Boiler model
2. Appliance G.C. No.
3. Description.
4. Quantity.
5. Product number.

When replacing any part on this appliance use only spare parts that you can be assured conform to the safety and performance specification that we require. Do not use reconditioned or copy parts that have not been clearly authorised by Ideal.

***** FOR DIAGRAMS REFER TO FRAME 6 - BOILER ASSEMBLY *****

| Key No. | G.C. Part No. | Description | Qty./boiler | Product Number |
|---------|---------------|----------------------------------|-------------|----------------|
| 107 | | Filling Loop | 1 | 175530 |
| 108 | | Pump Head Kit | 1 | 175670 |
| 110 | | Automatic Air Vent | 1 | 174894 |
| 111 | | Diverter Valve Head | 1 | 174813 |
| 112 | | Diverter Valve Cartridges | 1 | 175668 |
| 113 | | Pressure Relief Valve | 1 | 175413 |
| 118 | | Expansion Vessel | 1 | 175551 |
| 121 | | Plate Heat Exchanger | 24 | 175417 |
| | | Plate Heat Exchanger | 30 | 175418 |
| | | Plate Heat Exchanger | 35 | 175419 |
| 127 | | Flow Sensor (Hall Effect) | 1 | 175590 |
| 128 | | DHW Flow Turbine | 24 | 175660 |
| | | DHW Flow Turbine | 30 | 175661 |
| | | DHW Flow Turbine | 35 | 175662 |
| 131 | | Water Pressure Sensor | 1 | 175596 |
| 135 | | Pressure Gauge | 1 | 175679 |
| 205 | | Gas Valve kit | 1 | 175562 |
| 211 | | Injector & Housing | 24 | 175610 |
| | | Injector & Housing | 30 | 175611 |
| | | Injector & Housing | 35 | 175612 |
| 215 | | Fan Kit | 1 | 175569 |
| 217 | | Burner | 1 | 175571 |
| 229 | | Siphon Trap Kit | 1 | 175583 |
| 232 | | Turret Manifold Gasket | 1 | 175620 |
| 302 | | Primary PCB | 1 | 175939 |
| 302a | | Boiler Chip Card (BCC) | 24 | 175936 |
| | | Boiler Chip Card (BCC) | 30 | 175937 |
| | | Boiler Chip Card (BCC) | 35 | 175938 |
| 303 | | CUI Board | 1 | 175713 |
| 304 | | Control Thermistor (Flow/Return) | 2 | 175589 |
| 306 | | Ignition Electrode Kit | 1 | 175591 |
| 307 | | Detection Electrode Kit | 1 | 175592 |
| 308 | | Spark Generator | 1 | 175593 |
| 309 | | Thermistor - No Flow | 1 | 175594 |
| 313 | | Ignition lead | 1 | 175598 |
| 320 | | Detection Lead | 1 | 175604 |
| 328 | | Fuse - PCB | 1 | 175627 |
| 403 | | Heat Engine Gasket Kit | 1 | 175618 |
| 504 | | Front Panel | 1 | 175723 |
| 512 | | Front Panel Door | 1 | 175722 |

*Note that production boiler PCBs are factory pre-set to operate for boiler range and output, but when ordering Primary PCB as a spare, an additional Boiler Chip Card (BCC) MUST also be purchased for your specific boiler range and output.

Code Of Practice

For the installation, commissioning and servicing of domestic heating and hot water products

Benchmark places responsibilities on both manufacturers and installers.* The purpose is to ensure that customers** are provided with the correct equipment for their needs, that it is installed, commissioned and serviced in accordance with the manufacturer's instructions by competent persons and that it meets the requirements of the appropriate Building Regulations. Installers are required to carry out work in accordance with the following:

Standards of Work

- Be competent and qualified to undertake the work required.
- Install, commission, service and use products in accordance with the manufacturer's instructions provided.
- Ensure that where there is responsibility for design work, the installation is correctly sized and fit for purpose.
- Meet the requirements of the appropriate Building Regulations. Where this involves notifiable work be a member of a Competent Persons Scheme or confirm that the customer has notified Local Authority Building Control (LABC), prior to work commencing.
- Complete all relevant sections of the Benchmark Checklist/Service Record when carrying out commissioning or servicing of a product or system.
- Ensure that the product or system is left in a safe condition and, whenever possible, in good working order.
- Highlight to the customer any remedial or improvement work identified during the course of commissioning or servicing work.
- Refer to the manufacturer's helpline where assistance is needed.
- Report product faults and concerns to the manufacturer in a timely manner.

Customer Service

- Show the customer any identity card that is relevant to the work being carried out prior to commencement or on request.
- Give a full and clear explanation/demonstration of the product or system and its operation to the customer.
- Hand over the manufacturer's instructions, including the Benchmark Checklist, to the customer on completion of an installation.
- Obtain the customer's signature, on the Benchmark Checklist, to confirm satisfactory demonstration and receipt of manufacturer's instructions.
- Advise the customer that regular product servicing is needed, in line with manufacturers' recommendations, to ensure that safety and efficiency is maintained.
- Respond promptly to calls from a customer following completion of work, providing advice and assistance by phone and, if necessary, visiting the customer.
- Rectify any installation problems at no cost to the customer during the installer's guarantee period.



*The use of the word "installer" is not limited to installation itself and covers those carrying out installation, commissioning and/or servicing of heating and hot water products, or the use of supporting products (such as water treatment or test equipment).

**Customer includes householders, landlords and tenants.

For additional fault finding advice please visit our website

www.idealheating.com

Technical Training

The Ideal Technical Training Centre offers a series of first class training courses for domestic, commercial and industrial heating installers, engineers and system specifiers. For details of courses please ring:..... 01482 498 432



The code of practice for the installation, commissioning & servicing of central heating systems



FM 59915

Manufactured under an ISO 9001 registered quality management system

Ideal, P.O. Box 103, National Ave, Kingston upon Hull, HU5 4JN.
Telephone: 01482 492 251 Fax: 01482 448 858. Registration No.
London 322 137.

Ideal Stelrad Group pursues a policy of continuing improvement in the design and performance of its products. The right is therefore reserved to vary specification without notice.



Ideal Stelrad Group

Ideal Installer/Technical Helpline: 01482 498 663

www.idealheating.com