

# ATAG

## Installation & Servicing Instructions



iS 12  
iS 15  
iS 18  
iS 24  
iS 32  
iS 40







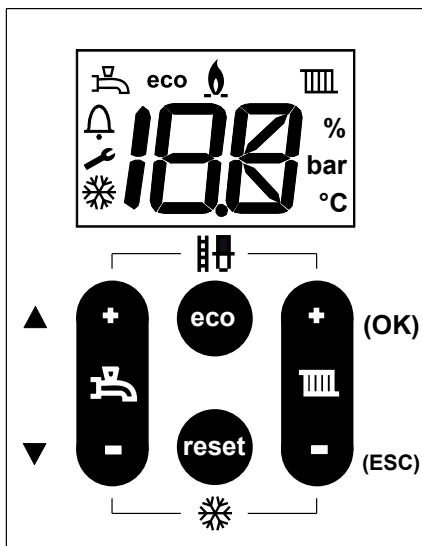

Natural Gas Boilers		Propane Gas Boilers	
<i>Boiler</i>	<i>G.C No</i>	<i>Boiler</i>	<i>G.C No</i>
iS 12	41-310-18	iS 12 LPG	41-310-19
iS 15	41-310-20	iS 15 LPG	41-310-21
iS 18	41-310-22	iS 18 LPG	41-310-23
iS 24	41-310-24	iS 24 LPG	41-310-25
iS 32	41-310-26	iS 32 LPG	41-310-27
iS 40	41-310-28	iS 40 LPG	41-310-29

**CE PIN 0063CQ3634**

## Explanation of the Control Panel & Buttons





-  DHW Visible when DHW program is active  
Flashing when there is a heat demand for DHW
-  Error Error indication (accompanied with a code).
-  Alert Service-mode or blocking
-  Pump Visible when pump is set to continuously  
Flashing when frost program is active
-  Flame Visible when boiler is active for heating or DHW
-  Heating Visible when heating program is active  
Flashing when there is a heat demand for heating

 **Central heating program (On = +, Off = -)**  
**Setting of boiler temperature (max. flow temperature)**  
 +/-function (ancillary function: OK and Escape)

 Press 6 seconds for Information

 Reset button

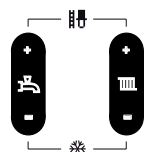
 **DHW button**  
 +/-function (ancillary function: Scroll and +/-function)

 Commissioning function (Press both + buttons for 6 seconds)  
 Pump function (Press both - buttons for 6 seconds)

### Information on the water pressure:



The default view of the display shows OK. Press the eco-button for 6 seconds and press the scroll-buttons until A6 is displayed. The actual water pressure will be shown:

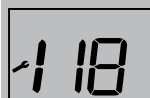

#### Water pressure too low

Code 118 and spanner symbol visible:

**Water pressure is too low (<1.0 bar).**

Power is reduced by 20%. The installation should be refilled.

or

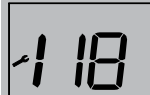

Code 118 and spanner symbol visible:

**Water pressure is too low (<0.7 bar).**

The boiler is taken out of operation. The installation should be refilled.



After the installation has been refilled and if the pressure was below 0.7 bar the de-aeration program will start (Code 105 and spanner symbol visible). This will last for approx 7 mins.

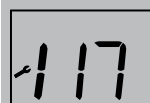

#### Water pressure too high

Code 117 and spanner symbol visible:

**Water pressure is too high (> 3.0 bar).**

The boiler is taken out of operation.

The installation pressure should be reduced by draining water from the heating system.

See chapter 12 for more information about button functions and read-out.

# Contents

1	Introduction .....	4
2	Rules & Regulations (Symbols) .....	5
3	Technical specifications.....	7
4	Dimensions .....	8
5	Delivery package.....	9
6	Boiler description.....	9
7	Boiler photo components list .....	10
8	Mounting boiler frame .....	11
	8.1 Wall frame .....	12
9	Connecting boiler .....	13
	9.1 Central heating system .....	13
	9.2 Expansion vessel.....	14
	9.3 Water quality .....	14
	9.4 Heating systems with plastic pipes .....	16
	9.5 Gas connection in general .....	16
	9.5.1 Natural gas connection (NG) .....	16
	9.5.2 Propane gas connection (LPG).....	16
	9.6 External DHW cylinder.....	18
	9.7 Condensation drain pipe.....	21
	9.8 Flue gas exhaust system .....	25
	9.8.1 Flue terminal locations .....	26
	9.8.2 Dimensioning of the flue gas and air intake duct .....	29
	9.9 Fitting the boiler onto the boiler frame .....	31
10	Electrical connection .....	33
	10.1 One controller & connections.....	34
	10.2 Weather compensation & connections .....	34
	10.3 Electrical diagram .....	35
11	Filling system .....	36
12	Boiler controls .....	37
	12.1 Controls and explanation of the functions.....	38
13	Commissioning the boiler.....	39
	13.1 Settings.....	41
	13.2 Parameter chapter .....	41
14	Isolating the boiler .....	42
15	Commissioning.....	43
	15.1 Checking the CO <sub>2</sub> .....	44
	15.2 Checking flue integrity.....	45
	15.3 CO and combustion checks .....	46
16	Routine servicing.....	48
	16.1 Component replacement.....	51
	16.2 User's instructions.....	52
	16.3 Maintenance frequency.....	52
	16.4 Warranty.....	52
17	Error codes and fault finding .....	53
	Annex A System water additives .....	54
	Annex B Declaration of conformity .....	55
	Annex C Short parts list.....	56



**Work on the installation should only be carried out by qualified personnel with calibrated equipment and appropriate tools.**



# 1 Introduction

These instructions describe the functioning, installation, use and primary maintenance of ATAG central heating boilers for the United Kingdom.

These instructions are intended for the use of Gas Safe registered installers in connection with the installation and putting into operation of ATAG boilers. It is advisable to read these instructions thoroughly, well in advance of installation. Separate instructions for use are supplied with the boiler for users of ATAG central heating boilers. ATAG is not liable for the consequences of mistakes or shortcomings which have found their way into the installation instructions or user's manual. Further, ATAG reserves the right to alter its products without prior notification.



**When delivering the boiler, give the customer clear instructions concerning its use; present the customer with the user's manual and warranty card.**

Each boiler is fitted with an identification plate. Consult the details on this plate to verify whether the boiler is compliant with its intended location, e.g.: gas type, power source and exhaust classification.

On completion of the installation the installer or commissioning engineer must fill out and complete the Benchmark Commissioning Checklist found on page 53 of this manual and hand this to the customer for future record keeping. The Benchmark Service Record must also be completed by the service agent following each service call, and return to the customer.

## 2 Rules & Regulations (Symbols)

The following regulations apply to installation of ATAG central heating boilers:

Legislation and Regulations.

Gas Safety (Installation and Use). All gas appliances must by law, be installed by a competent person, eg. Members of Gas Safe Register and in accordance with the current Gas Safety Regulation. Failure to install appliance correctly could lead to prosecution.

All Gas Safe registered installers carry a Gas Safe ID card and have a registration number. You can call Gas Safe Register directly on 0800 408 5577.

In addition to the above regulations this appliance must be installed in compliance with the current IEE Regulations, the Building Standards (Scotland Consolidation) Regulations. Regulations and bye laws of the Local Water Authority and the Current Health and Safety Regulation.

### The Benchmark Scheme

Benchmark places responsibilities on both manufacturers and installers. The purpose is to ensure that customers are provided with the correct equipment for their needs, that it is installed, commissioned and serviced in accordance with the manufacturer's instructions by competent persons and that it meets the requirements of the appropriate Building Regulations. The Benchmark Checklist can be used to demonstrate compliance with Building Regulations and should be provided to the customer for future reference.



Installers are required to carry out installation, commissioning and servicing work in accordance with the Benchmark Code of Practice which is available from the Heating and Hotwater Industry Council who manage and promote the Scheme.

Visit [www.centralheating.co.uk](http://www.centralheating.co.uk) for more information.

The current Electricity at Work Regulation must be complied with and also be in accordance with the relevant and current editions of the British Standards.

The ATAG iS boiler is a certified appliance and must not be modified or installed in any way contrary to this Installation Manual. Manufacturers instructions must not be taken, in any way, as overriding statutory obligations.

The ATAG iS boiler is a central heating boiler with an integrated hot water function. The boiler must be connected according to these instructions and all installation norms in respect of the part of the boiler to be connected.



**The appliance is not to be used by children or persons with reduced physical, sensory or mental capabilities, or lack of experience and knowledge, unless they have been given supervision or instruction.**



**Children being supervised not to play with the appliance.**

Observe the following rules of safety:

- All work on the boiler must take place in a dry environment.
- ATAG boilers may never be in operation without their housing, except in connection with maintenance or adjustments (see Chapter 15 and 16).
- Never allow electrical or electronic components to come into contact with water.

Carry out the following tasks in connection with maintenance, etc. to an already-installed boiler:

- Shut down all programs
- Close the gas isolation valve
- Shut down the 230V power supply

See chapter 15 and 16 for further instructions.

Take note of the following when maintenance or adjustments are needed:

- The boiler must be able to function during these activities; for this reason, the boiler's 230V power supply, gas pressure and water pressure must be maintained. Ensure that there is not a source of potential danger during these activities.



**Following maintenance or other activities; always check the installation of all parts through which gas flows (using leak detection spray).**

The following (safety) symbols may be encountered in these installation instructions and on the boiler (packaging):



**Boiler must be stored away from frost.**



**Protect packaging and/or contents from damage as a result of insufficient care taken during transport.**



**Protect the boiler from weather conditions during transport and storage whilst still in its packaging.**



**If and how to clamp when using transport trucks with clamp equipment.**



**If and how to transport when using a rolling jack.**



**The whole packaging is made of recycled materials and can be recycled again.**



**Transport and place the boiler in its packaging in this position.**



**Do not to step on or stand on the package.**



**An assembly or dismantling must be carried out.**



**Pay extra attention in connection with a particular operation.**



**Useful tip or advice**

### 3 Technical specifications

#### Technical specifications Natural gas

Boiler type	ATAG iS-Series						
	System						
		iS 12	iS 15	iS 18	iS 24	iS 32	iS 40
Type heat exchanger		iCon1	iCon1	iCon1	iCon1	iCon2	iCon2
Input CH Net	kW	10.8	13.5	16.2	21.6	28.8	36.0
Q <sub>n</sub> Input CH Gross	kW	12.0	15.0	18.0	24.0	32.0	40.0
Modulation range CH (capacity 50/30°C)	kW	5.0 - 11.8	5.0 - 14.7	5.0 - 17.5	5.0 - 23.2	6.9 - 31.2	6.9 - 38.8
Nox class EN15502-1		5					
O <sub>2</sub> (at full load)	%	4.7					
CO <sub>2</sub> (at full load)	%	9.0					
Temperature class flue		T100					
Appliance type		B23, B33, C13, C33, C43, C53, C63, C83, C93					
Flue gas temp. CH (80/60°C on full load)	°C	59				59	
Flue gas temp. CH (50/30°C on low load)	°C	29				30	
Categories		II2H3P					
Gas consumption	m <sup>3</sup> /hr	1.14	1.43	1.72	2.29	3.05	3.81
Electr. power consumption max.	W	62	68	77	96	74	99
Electr. power consumption part load	W	47	51	58	72	56	74
Electr. power consumption stand by	W	5					
Current	V/Hz	230/50					
Degree of protection acc. EN 60529		IPX4D (B22/B33 IPX0D)					
Weight boiler + jig (empty)	kg	39	39	39	39	42	42
Width	mm	440	440	440	440	440	440
Height (excl. flue)	mm	700	700	700	700	700	700
Depth	mm	355	355	355	355	355	355
Overrun time pump CH	sec	60					
Content expansion vessel	l	8	8	8	8	8	8
Pre-charge pressure exp. Vessel	bar	1	1	1	1	1	1
P <sub>MS</sub> Water pressure CH min./max.	bar	1/3					
Flow temperature max.	°C	85					
Pump type		UMP3 15-75					
Available pump height CH	kPa	25	25	25	25	20	20
SAP Annual Efficiency NG	%	89.8	89.8	89.8	89.8	89.8	89.8
CE product identification number(PIN)		0063CQ3634					

#### Technical specifications Propane gas





Boiler type		iS 12	iS 15	iS 18	iS 24	iS 32	iS 40
Heat exchanger type		iCon1	iCon1	iCon1	iCon2	iCon2	iCon2
O <sub>2</sub> (at full load)	%	5.1					
CO <sub>2</sub> (at full load)	%	10.3					
Pre pressure	mbar	see data plate LPG					
Input CH Net	kW	10.8	13.5	16.2	21.6	28.8	36.0
Gas consumption	m <sup>3</sup> /hr	0.45	0.56	0.68	0.90	1.20	1.50
Output (80/60°C)	kW	10.7	13.3	15.9	21.2	28.4	35.4
Output (50/30°C)	kW	11.8	14.7	17.5	23.2	31.2	38.8
Weight boiler + jig (empty)	kg	39	39	39	42	42	42

#### ErP specifications according to European Guideline 2010/30/EU

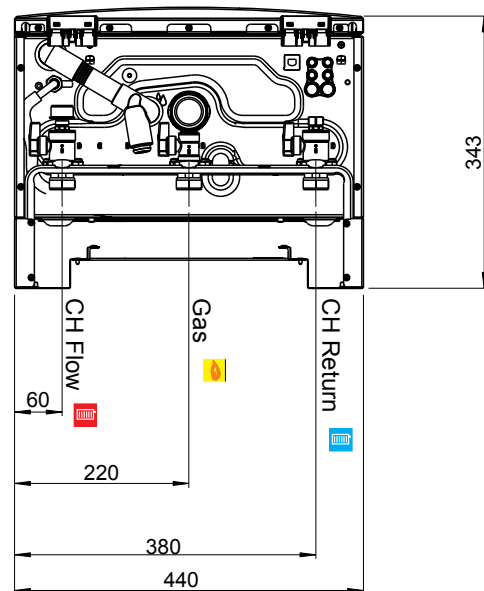
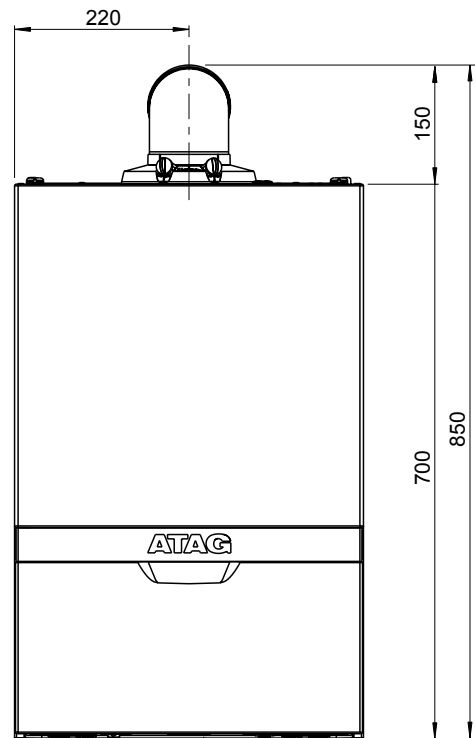
Boiler type		iS 12	iS 15	iS 18	iS 24	iS 32	iS 40
Seasonal space heating energy efficiency class		<b>A</b>	<b>A</b>	<b>A</b>	<b>A</b>	<b>A</b>	<b>A</b>
P <sub>n</sub> Power output	kW	11	13	16	21	28	35
Q <sub>HE</sub> Annual energy consumption	GJ	3	4	5	7	9	12
η <sub>s</sub> Seasonal space heating energy efficiency	%	93	93	93	94	94	94
L <sub>WA</sub> Sound power level, indoors	dB	37	37	43	46	48	54

## 4 Dimensions



		ATAG iS-Series					
		System					
		iS 12	iS 15	iS 18	iS 24	iS 32	iS 40
Flue gas / Air intake	A/B				60/100		
 Gas connection					22		
 CH Flow connection					22		
 CH Return connection					22		
 Condensate drain connection					21.5		

## 5 Delivery package

The delivery package of the boiler is composed as follows:

- Boiler frame;
- Boiler with cover;
- Automatic air vent (in boiler);
- Safety valve 3 bar (in boiler);
- Automatic by-pass (in boiler);
- Expansion vessel 8 litre / 1 bar (in boiler frame);
- Isolation valves with drainpoint (CH 2x,)
- Gas isolating valve;
- Fittings consisting of plugs and screws;
- Drawing template;
- Installation instructions;
- User manual;
- Warranty Card.

The following components are not present in the boiler packaging as a standard and should be included in the installation according to the requirements:

- Flue system;
- External controls.

## 6 Boiler description

The ATAG iS is a room sealed, condensing and modulating CH boiler.

The boiler is equipped with a compact stainless steel heat exchanger with smooth pipes. It is a well thought-out principle using sustainable materials.

The boiler burns gas to supply heat (natural gas and LPG versions available). This heat is transferred in the heat exchanger to the water in the CH installation. The rapid cooling off of the flue gases causes condensation. This results in a very high efficiency. The condensate that is formed, has no negative impact on the heat exchanger and it's operation, and is removed through the internal siphon. This feature requires a condensate drain pipe connected to the drain of the building.

The boiler is equipped with an intelligent control system. The boiler anticipates on the heat demand of the heating installation or hot water demand. This will cause the boiler to tune its capacity to the installation. This means that the boiler will function longer and at a low level.

 The boiler has been tested according to valid CE standards and has a CE certificate and >88% Efficient SEDBUK 2009.

 **Statement: No banned materials including asbestos, mercury, CFC's have or will not be included in the product.**

## 7 Boiler photo components list



ATAG iS

Figure 7.a

1	Heat exchanger	9	Circulation pump	17	Isolation valve gas
2	Ignition unit	10	Flue gas exhaust	18	Isolation valve return CH
3	Fan unit	11	Combustion air supply		
4	Air supply damper	12	Boiler data plate		
5	Gas valve	13	Expansion vessel		
6	Automatic de-aerator	14	Safety valve		
7	Control unit	15	Siphon		
8	Control panel	16	Isolation valve flow CH		

T1 Flow sensor  
T2 Return sensor  
P1 Water pressure sensor

G Gas pipe  
A Flow pipe CH  
R Return pipe CH  
C Condensation pipe

## 8 Mounting boiler frame



**Install the boiler in a boiler room in accordance to the actual local regulations BS5440-2:2000.**

The installation location of the boiler has to be, and remain, frost-free. The boiler casing is splash water tight (IPX4D) and is suitable to be installed in e.g. a bathroom.

It is NOT necessary to have a purpose provided air vent in the room or internal space in which the boiler is installed. Neither is it necessary to ventilate a cupboard or compartment in which the boiler is installed, due to the extremely low surface temperature of the boiler casing during operation. Therefore the requirements of BS 6798, Clause 12, and BS5440:2 may be disregarded.

The boiler can be mounted practically to any wall with the wall frame and the enclosed fixing equipment. The wall must be flat and of sufficient strength in order to be able to carry the boiler weight with its water content. Above the boiler there must be at least 175 mm working space in order to be able to fit a horizontal concentric flue system to the rear (See chapter 9.8 for more flue options). Make sure there is sufficient service space around the boiler according figure 8.a. The location of the boiler can be determined by using the template.

The wall frame allows the possibility to pre-fit the complete heating system before fitting the boiler. Also the flue system can be prepared. Finally fitting of the flue system is done after fitting the boiler. See next page for all options for connection the heating, condensate, flue and gas installation.

Before hanging the boiler to the boiler frame remove the front panel of the boiler first. The front panel is also the air cabinet and is attached to the boiler case with 2 fasteners (A and B) (see figure 8.a).



**Note that there is an earth cable to disconnect when removing the boiler front panel. Free space for removing the connector is about 400 mm. Remember to connect this earth cable when placing back the boiler front panel and take care the wire does not get stuck between front panel and boiler.**

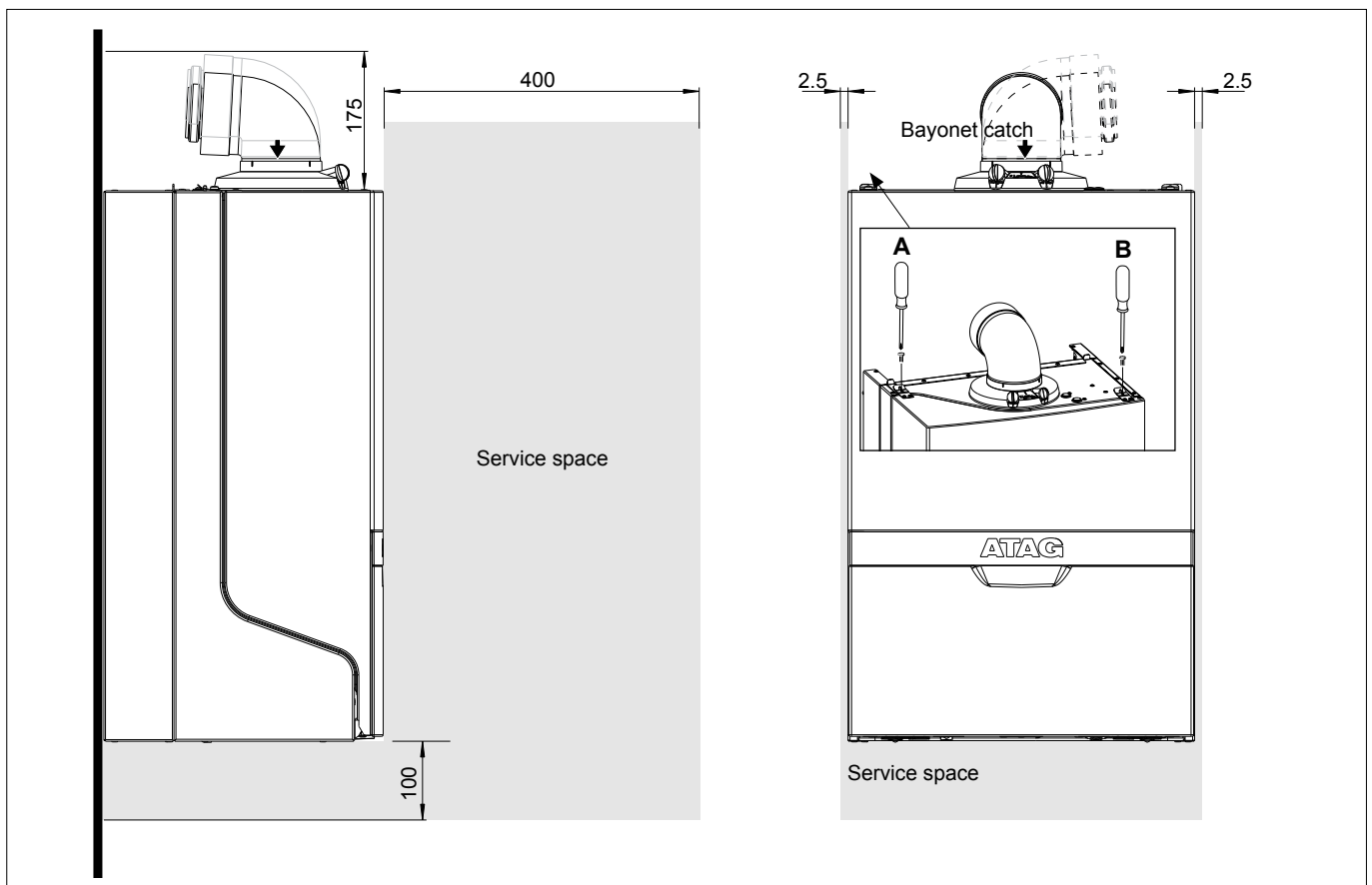

Service dimensions (in mm)

Figure 8.a

See chapter 9.8 for further procedure to fit the boiler onto the boiler frame.

## 8.1 Wall frame

- Position the boiler frame against the wall using the template and a level.
- Use the level for horizontal positioning and checking the vertical position.
- Drill 4x  $\varnothing 10\text{mm}$  holes, 60mm deep
- Press the nylon wall plug ( $\varnothing 10 \times 55\text{mm}$ ) in the holes
- Mount the boiler frame to wall with the 4 coach screws ( $\varnothing 8 \times 60\text{mm}$ ) using a 13mm wrench

The boiler frame allows pipe work to be installed behind the boiler.



**Note that there are free spaces on the left and right of the expansion vessel. Do not guide pipe work in front of the expansion vessel. The pipe work must be installed at least 10mm inside the front of the frame.**

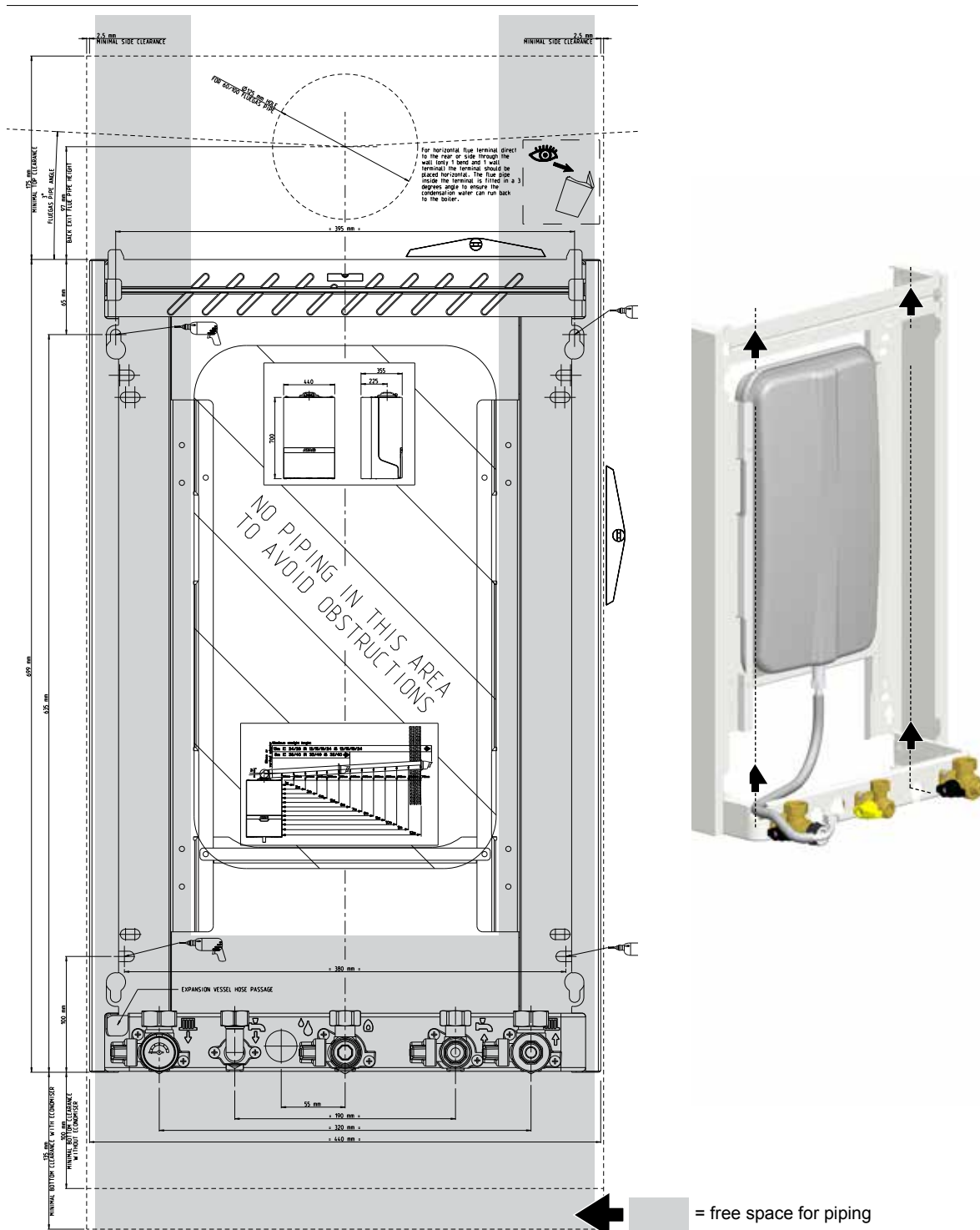

ATAG i-Series template and boiler frame

Figure 8.1.a

## 9 Connecting boiler

The boiler has the following connection pipes;

- The central heating pipes.  
*The boiler is provided with isolation valves on the flow and return pipe to which the installation can be connected by means of 22mm compression fittings;*
- The gas pipe.  
*The boiler is provided with an isolation gas valve to which the gas line can be fitted with 22mm compression fitting;*
- The condensation drain pipe.  
*It consists of a 25mm flexible plastic pipe. The drain pipe can be connected to this by means of an open connection;*
- The flue gas exhaust system and air supply system.  
*It consists of a concentric connection 60/100 mm.*

See following chapters for detailed information regarding each connection.



**It is advisable to clean all of the boiler's connecting pipes and/or to power flush the installation before connecting it to the boiler.**

### 9.1 Central heating system

Connect the central heating system according to the current regulations.

The boiler pipes can be connected to the installation by means of 22mm compression fittings. For connecting to thick-walled pipe (welded or fitted), adapters should be used.

The boiler has a self-adjusting and self-protecting control system for the load. This involves checking the temperature difference between the flow and return water. Table 9.1.a shows the water displacement the circulation pump can deliver for a particular installation resistance.

If the installation resistance is higher than the value stated, the control system will adjust the load until a temperature difference between flow and return water is reached that is acceptable for the control system. When the temperature difference still remains too high the boiler will switch itself off and wait until the high temperature differential between the flow and return water has decreased again.

Boiler type	Pump type	Water flow rate at $\Delta T$ 20°C		Permissible installation resistance	
		l/min	l/h	kPa	mbar
	<b>Grundfos</b>				
iS 12	UPM3 15-75	7.6	460	25	250
iS 15	UPM3 15-75	9.5	570	25	250
iS 18	UPM3 15-75	11.4	680	25	250
iS 24	UPM3 15-75	15.2	910	25	250
iS 32	UPM3 15-75	20.3	1220	20	200
iS 40	UPM3 15-75	25.3	1520	20	200

Installation resistance

table 9.1.a

The control system will, if an unacceptable temperature difference is detected, repeatedly try to establish a water flow. If this does not succeed, the boiler will block itself (code 154).



The boiler is NOT equipped with a built-in internal filter.

**Advice:** ATAG Heating Technology Ltd recommend the installation of an in-line filter installed into the heating return as close to the boiler as possible. ATAG Heating Technology Ltd recommend the use of the:

ATAG iGuard Magnetic filter 22mm (Plastic) FC000100, (Brass) FC000200, 28mm (Brass) FC000250.



The boiler is not suitable for installations that are equipped with “open” expansion tanks.



Additives in the installation water are only permitted in consultation with the country distributor. See chapter 9.3 for detailed information.

## 9.2 Expansion vessel

The iS boilers are featured with a built-in expansion vessel with a capacity of 8 litres and a pre-pressure charge 1 bar. If the expansion vessel size is insufficient for the CH system, an additional expansion must be installed. The additional expansion vessel should, together with the built-in expansion vessel, be sized to the water content of the installation. The pre-pressure charge depends on the height of the installation above the installed expansion vessel. See Table 9.2.a.



The (additional) expansion vessel should be connected as closely as possible in the return pipe near the boiler.

Installation height above the expansion vessel	pre-charge pressure of the expansion vessel
5m	0,5 bar
10m	1,0 bar
15m	1,5 bar

table 9.2.a

The pressure relief valve outlet is combined with the condensate outlet (see figure 9.8.e on page 29).

## 9.3 Water quality

Fill the installation with mains cold water.

In most cases, a heating system can be filled with water according to national standards for water and treatment of this water is not necessary.

In order to avoid problems with the CH-installations, the quality of the filling water has to meet the specifications mentioned in table 9.3.a:

If the filling water does not meet the required specifications, you are advised to treat the water to such an extent that it does meet the required specifications.



**The warranty becomes invalid, if the installation is not being flushed and/or the quality of the filling water does not meet the specifications recommended by ATAG Heating Technology Ltd. Always contact ATAG Heating Technology Ltd in advance, if things are not clear or you wish to discuss any deviations. Without approval, the warranty becomes invalid.**

Installation:

- The use of groundwater, demi-water and distilled water is prohibited. (on the next page you will find an explanation of these definitions)
- If the mains water quality meets the specifications mentioned in table 9.3.a, you can start flushing the installation before installing the device.
- Whilst flushing, corrosion products (magnetite), fitting products, cutting oil and other undesirable products have to be removed.
- Another possibility is to remove the pollution by installing a filter. The filter type has to fit the type and grain size of the pollution. ATAG Heating Technology Ltd recommends filter usage.
- In this case, the whole piping system should be taken into consideration.
- The CH-installation has to be properly vented before using the system. For that purpose, we refer to the commissioning chapter.

- If a regular water top up is required (>5% on an annual basis), then there is a structural problem and an installer has to solve the problem. Regularly adding fresh water to the system also adds additional calcium and oxygen implying that magnetite and calcium residues can continue. The result may be blockages and/or leakages.
- The use of anti-freeze and other additives requires periodical quality checks of the filling water in accordance with the period laid down by the additives supplier.
- Chemical additions are to be avoided and should only be used after ATAG Heating Technology Ltd has approved their corresponding use.
- Should you wish to achieve the required water quality by using chemical additives, then this is your own responsibility. The warranty on the product delivered by ATAG Heating Technology Ltd expires, if the water quality does not meet ATAG Heating Technology's specifications or the chemical additives have not been approved by ATAG Heating Technology Ltd.
- On installation and during additions or changes at a later stage, ATAG Heating Technology Ltd recommends to keep a record of the type of water used, its quality at the time, and if applicable, which additives and quantities were added.

Parameter	Value
Water type	Potable water Softened water
pH	6.0-8.5
Conductivity (at 20°C in µS/cm)	Max. 2500
Iron (ppm)	Max. 0.2
Hardness (°dH / ppm):	
Installation volume/capacity <20 l/kW	1-12 °dH / 17-214 ppm
Installation volume/capacity ≥20 l/kW	1-7 °dH / 17-125 ppm
Oxygen	No oxygen diffusion allowed during operation. Max. 5% filling water addition annually
Corrosion inhibitors	Refer to Additives Attachment
pH increasing or lowering agents	Refer to Additives Attachment
Anti-freeze additives	Refer to Additives Attachment
Other chemical additives	Refer to Additives Attachment
Solid substances	Not allowed
Residues of processing water not forming part of the drinking water	Not allowed

table 9.3.a

#### Water type definition:

Potable water: Tap water compliant with the European drinking water guideline: 98/83/EG dated 3 November 1998.

Softened water: Water with partly de-ionised calcium and magnesium.

Demi-water: Virtually completely demineralised water (very low conductivity)

Distilled water: Water no longer containing minerals.

## 9.4 Heating systems with plastic pipes

When connecting or using an underfloor heating system, designed with plastic pipes, or plastic pipes are used elsewhere in the installation, one should ensure that the plastic pipes used comply with the DIN 4726/4729 standard. It is set out in this standard that the pipes may not have oxygen permeability higher than 0.1 g/m<sup>3</sup>.d at 40°C. If the system does not comply with this DIN standard, the underfloor heating component will have to be separated from the central heating appliance by means of a plate exchanger.



**No recourse can be made to the terms of the warranty in the event of failure to observe the regulations pertaining to plastic underfloor heating pipes.**

## 9.5 Gas connection in general

The local gas supplier should be consulted, at the installation planning stage, in order to establish the availability of an adequate supply of gas. An existing service pipe must NOT be used without prior consultation with the local gas supplier.



**ATAG supplies boilers suitable for natural gas only and boilers for LPG only. Verify the identification plate on the boiler if the boiler is suitable for the gas kind on site. The boilers cannot be converted to another kind of gas.**



**Make sure that the gas pipe work does not contain dirt, particularly with new pipes.**



**The complete installation MUST be tested for gas tightness and purged as described in the above code.**

The boiler connection is provided with an isolation valve with 22mm compression fitting, into which the gas line can be fitted.

### 9.5.1 Natural gas connection (NG)

The gas supply must comply to the current Gas Safety, Installation & Use Regulations, in accordance with BS.6891.

The nominal inlet working gas pressure measured at the appliance should be 21 mbar +/- 2 mbar for Nat gas (G20). Allowing for the acceptable pressure loss of 1 mbar across the installation pipework, it can be assumed that a minimum permitted operating pressure of 18 mbar will be delivered to the inlet of the appliance. (Reference BS 6400-1 Clause 6.2 Pressure Absorption). When tested at the gas valve, the pressure drop from the meter to the gas valve must not be more than 3.8 mbar.

### 9.5.2 Propane gas connection (LPG)

The LPG installation has to comply with British Standard 813 and Domestic Gas Installations



**Installing of a LPG installation should only be done by a registered LPG installer.**

The tank must be provided with a high pressure regulator with a minimum capacity of 24 kg/h to reduce the tank pressure from 5 to 1,5 bar. The 1,5 bar high pressure gas line should have a minimum diameter of 15mm. In the high pressure gas line a house pressure regulator must be installed. When tested at the gas valve, the pressure drop from the pressure regulator to the gas valve must not be more than 3.7 mbar.

### 9.5.3 House pressure regulator

**!** Each gas appliance which is connected to the propane installation must be provided with its own house pressure regulator. The house pressure regulator is a third party delivery.

The house pressure regulator must have a minimum capacity of 10 kg/h / 30 mbar and a CE certification.

ATAG advises to install the house pressure regulator as close as possible to the boiler. When placing the regulator inside, a discharge drain of  $\varnothing 6\text{mm}$  must be installed. The discharge drain must be directed outdoor. In case of a discharge the gasses will go outside.

If fitting the regulator outside the regulator should be protected against influences of the weather. The (de-)aeration must be positioned downwards (see figure 9.5.3.a).

ATAG advises to install measure points on all gas line parts to have the possibility to check for pressure loss.

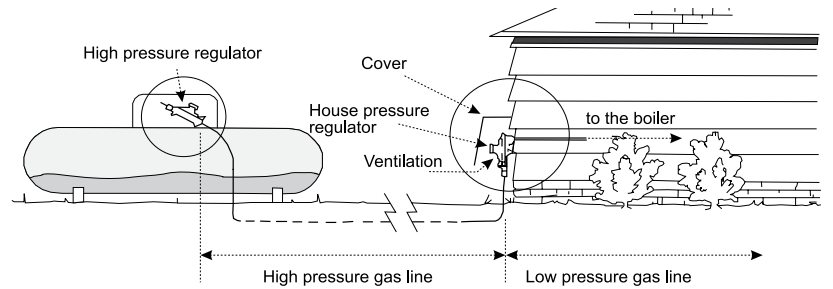

example propane installation

figure 9.5.3.a

**!** Pre-pressure must be adjusted to 30 mbar by means of the house pressure regulator. The maximum permitted closing pressure may be 5 mbar higher than the maximum pre-pressure.

A too high closing pressure in the low pressure gas line can be caused by a high resistance or jam in this gas line. When the closing pressure keeps increasing the valve in the regulator is not closing correctly. In this case the regulator should be replaced.

### 9.5.4 Dimensioning of the low pressure gas line

The gas line from the house pressure regulator to the boiler must have the dimensions according the table below.

Boiler type	iC 24	iC 28	iC 36	iC 40	iC Economiser 27	iC Economiser 35	iC Economiser 39
Diameter gas line	m	m	m	m	m	m	m
$\varnothing 15\text{mm}$	3	-	-	-	-	-	-
$\varnothing 22\text{mm}$	30	18	18	18	18	18	18
$\varnothing 28\text{mm}$	-	30	30	30	30	30	30

### 9.5.5 De-aerating the LPG tank

**!** When placing a new or revised LPG tank the tank must always be de-aerated.

ATAG advises to inform the gas supplier that a central heating boiler is connected to the LPG tank. For the boiler it is absolutely necessary that the tank is free of air. When not the boiler will give ignition problems and will not function.

ATAG advises to measure the content of  $\text{O}_2$ . This value should be lower than 1,3%. Contact the gas supplier in case of doubt.

## 9.6 External DHW cylinder

### **ATAG 3-port external diverter valve kit including the ONE controller (CT500111) used with a vented hot water cylinder.**

The ATAG 3-port diverter valve is to be fitted external to the boiler on the system pipework with the electrical wiring routed back to the wiring loom diverter valve connection within the iS boiler with a connection plug and wire included with in the 3-port diverter valve kit.

The installation will use the cylinder sensor supplied within the 3-port diverter valve kit to control the hot water temperature. Therefore no other cylinder thermostat is required.

The ONE controller will control the heating and hot water time and temperature requirements.

The weather compensation for heating will be controlled by the boiler and ONE controller via the internet connection and postal code weather data. An optional outside sensor (ARZ0055U) can be added to the 3-port diverter valve kit to sense the outside temperature specifically for the individual property.

### **Fitting the cylinder temperature sensor**

The cylinder sensor may be fitted into a sensor pocket if available, please refer to the cylinder manufactures instructions. If there is no sensor pocket, as found with foam covered cylinders then the following steps should be followed.

1. Mark a rectangular section of approximately 50mm (w) x 100mm (h) about one third of the cylinder height up from the bottom of the cylinder.

**Caution: Cut carefully. Do not pierce the wall of the cylinder or cut away any metal insulation outer casing.**

2. Using a sharp knife, carefully cut through the insulation, remove and retain the piece of insulation.
3. Clear off any excess material from the surface of the cylinder to ensure the best contact.
4. Place the sensor in position on the cylinder body and hold in place with aluminium tape and where available apply heat conductive paste.
5. Replace the previously removed insulation material
6. Secure the insulation in place with suitable tape or strapping.

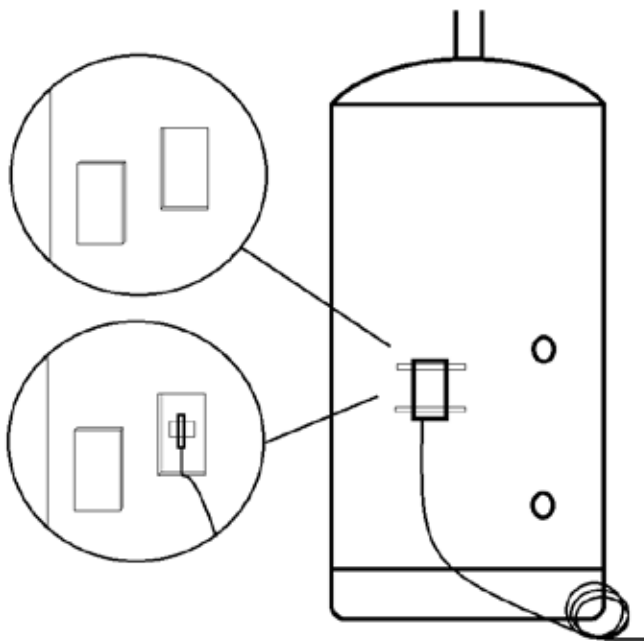

Figure 9.6.a

### **Wiring of components**

Connect the 3-port diverter valve to the spare 3-port valve connector on the wiring loom.

Connect the cylinder sensor with the yellow connector to the yellow DHW volt free position and the ONE control wires with the blue connector to the blue BUS volt free position on the back of the control panel.

### 3-port diverter valve

Install the 3-port diverter valve on the system pipework with the valve ports in the following orientation, AB port iS System boiler, A port hot water cylinder & B port heating system.

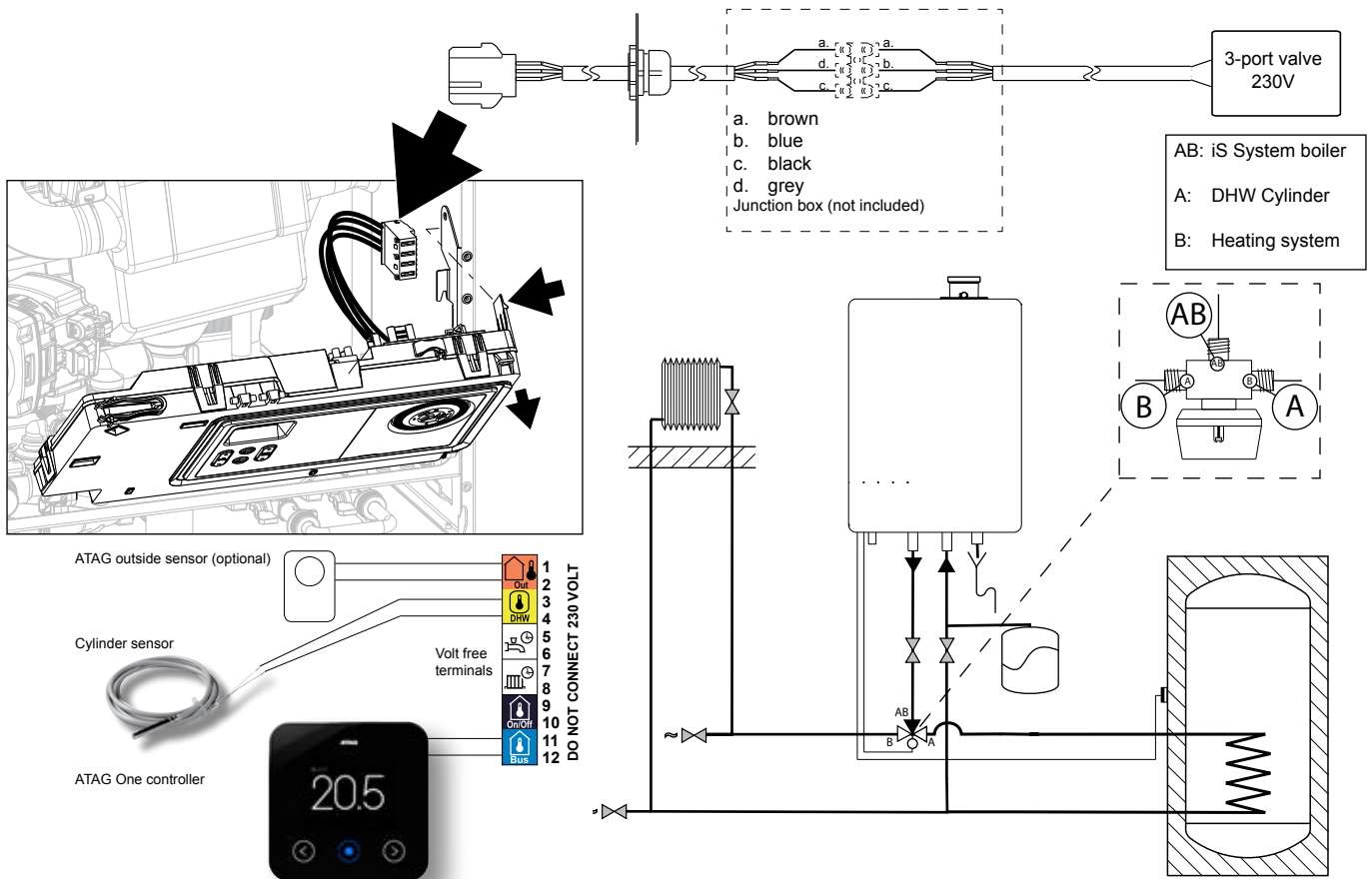

Figure 9.6.b

### ATAG 3-port external diverter valve kit including the ONE controller (CT500111) used with an unvented hot water cylinder.

The ATAG 3-port diverter valve is to be fitted external to the boiler on the system pipework with the electrical wiring routed back to the wiring loom diverter valve connection within the iS boiler with a connection plug and wire included with in the 3-port diverter valve kit.

The installation will use the cylinder sensor supplied within the 3-port diverter valve kit to control the hot water temperature. Therefore no other cylinder thermostat is required.

The ONE controller will control the heating and hot water time and temperature requirements.

The weather compensation for heating will be controlled by the boiler and ONE controller via the internet connection and postal code weather data. An optional outside sensor (ARZ0055U) can be added to the 3-port diverter valve kit to sense the outside temperature specifically for the individual property.

The installation may require altered wiring of the dual thermostat (depending on the cylinder the manufacturer) to only use the high limit thermal cut-out of the dual thermostat.

The high limit thermal cut-out of the dual thermostat MUST be wired to interrupt the power to the 2-port valve supplied with the unvented cylinder.

### Fitting the cylinder temperature sensor

The cylinder sensor is to be fitted into a sensor pocket of the unvented cylinder along with the dual thermostat supplied with the unvented cylinder.

### Wiring of components

Connect the 3-port diverter valve to the spare 3-port valve connector on the wiring loom.

Connect the cylinder sensor with the yellow connector to the yellow DHW volt free position and the ONE control wires with the blue connector to the blue BUS volt free position on the back of the control panel.

**2 port zone valve & dual thermostat (supplied with unvented cylinder)**

The 2-port zone valve must be installed in the primary flow pipework between the 3-port valve and the cylinder connection as per the following diagram and G3 unvented hot water requirements.

The 230v mains power supply **MUST** be wired only to the high limit thermal cut-out of the dual thermostat and be wired to interrupt the power to the motor of the 2-port valve as per electrical diagram below.

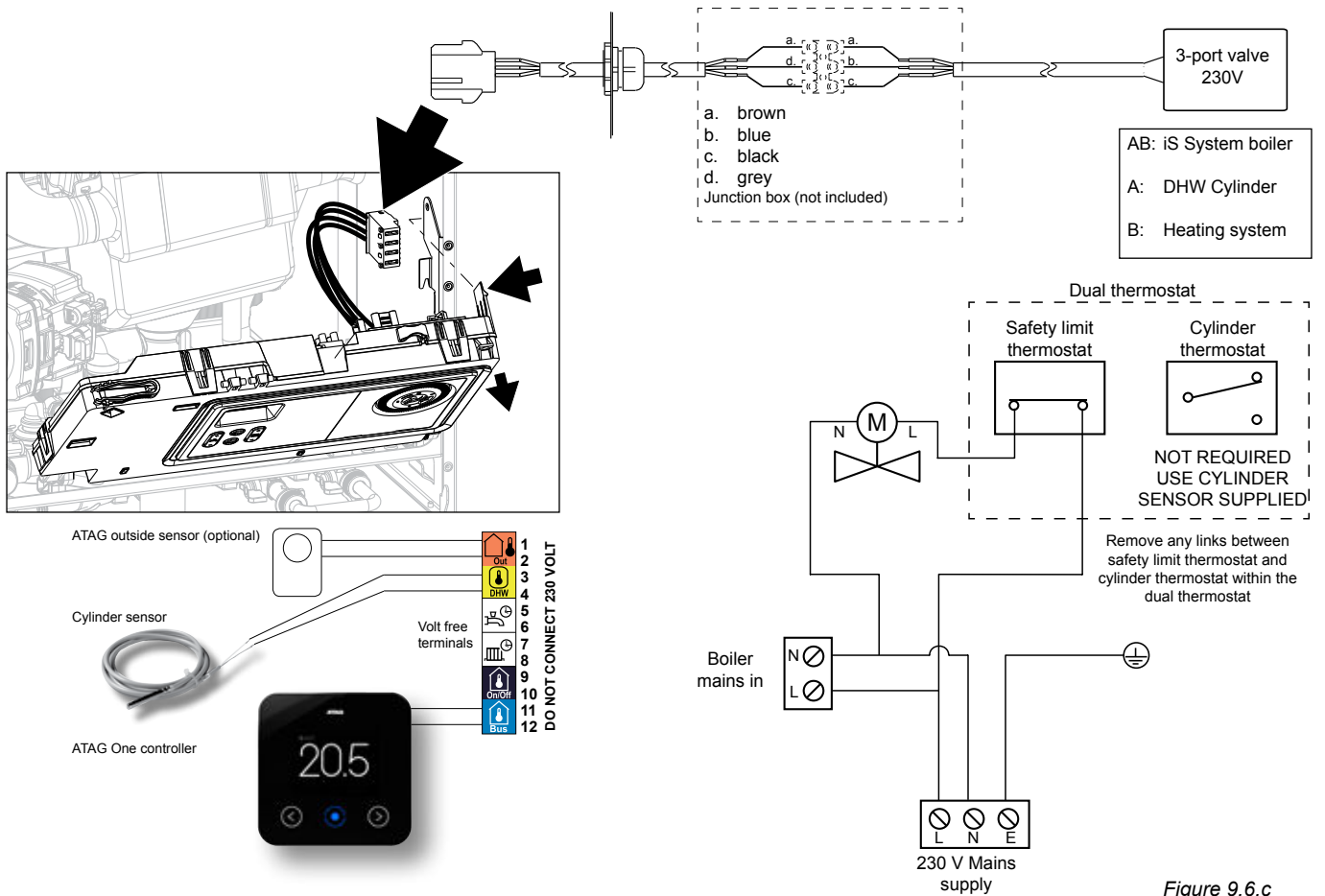

Figure 9.6.c

**3-port diverter valve**

Install the 3-port diverter valve on the system pipework with the valve ports in the following orientation, AB port iS System boiler, A port hot water cylinder & B port heating system.

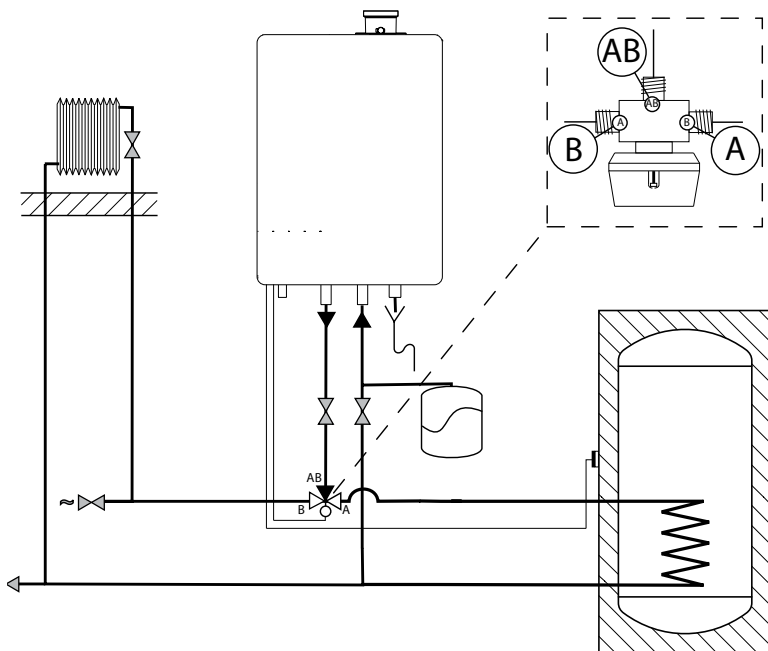

Figure 9.6.d

## 9.7 Condensation drain pipe

The ATAG condensing boiler has the >88% Efficient SEDBUK 2009 for high energy efficiency in heating and domestic hot water. The ATAG wall hung gas fired condensing boiler contain a siphonic condensate trap to collect and release condensate. The amount of condensate formed is determined by the type of boiler and the water temperature produced by the boiler.

### **Condensate pipework.**

Use plastic pipework of an internal diameter no less than 19mm ID (typically 22mm OD).

### **Routing of the pipework.**

The condensate pipework must fall at least 45mm per metre away from the boiler, taking the shortest practicable route to the termination point.

Support the pipe at least every 50 cm for near horizontal sections and 1 metre for vertical sections.

Wherever possible, the condensate pipework should be routed internally to prevent freezing. In order to minimise the risk of freezing during prolonged very cold spells, one of the following methods of terminating condensate drainage pipe should be adopted.

### **Internal pipework**

Wherever possible, the condensate drainage pipe should be terminated at a suitable internal foul water discharge point such as (a) an internal soil and vent stack or (b) an internal kitchen or bathroom waste pipe, washing machine waste pipe etc. A suitable permanent connection to the foul waste pipe should be used.

Figures 9.7.1, 9.7.2(a), 9.7.2(b) show appropriate connection methods.

The possibility of waste pipes freezing downstream of the connection point should be considered when determining a suitable connection point - e.g. a slightly longer pipe run to an internal soil stack may be preferable to a shorter run connecting into a kitchen waste pipe discharging directly through the wall to an external drain.

Where "gravity discharge" to an internal termination is not physically possible (e.g. the discharge point is above the appliance location, or access is obstructed by a doorway), or where very long internal pipe runs would be required to reach a suitable discharge point, the following measures may be adopted.

### **Use of a condensate pump (to an internal termination):**

Condensate can be removed using a proprietary condensate pump (third party delivery), of a specification recommended by the pump manufacturer. Condensate pump suitable for combined pressure relief valve.

The pump outlet should discharge to a suitable internal foul water discharge point, such as (a) an internal soil and vent stack or (b) an internal kitchen or bathroom waste pipe, washing machine waste pipe etc. Figure 9.7.3 shows a typical connection method.

A suitable permanent connection to the foul waste pipe should be used and the manufacturer's detailed installation instructions for the pump should be followed.

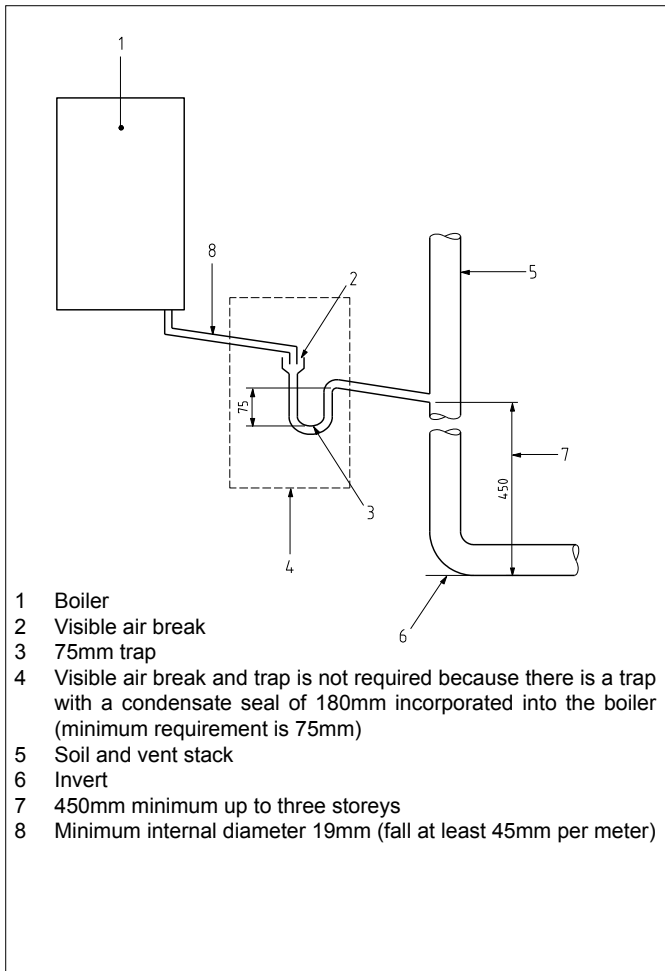

Drain requirements

Figure 9.7.1

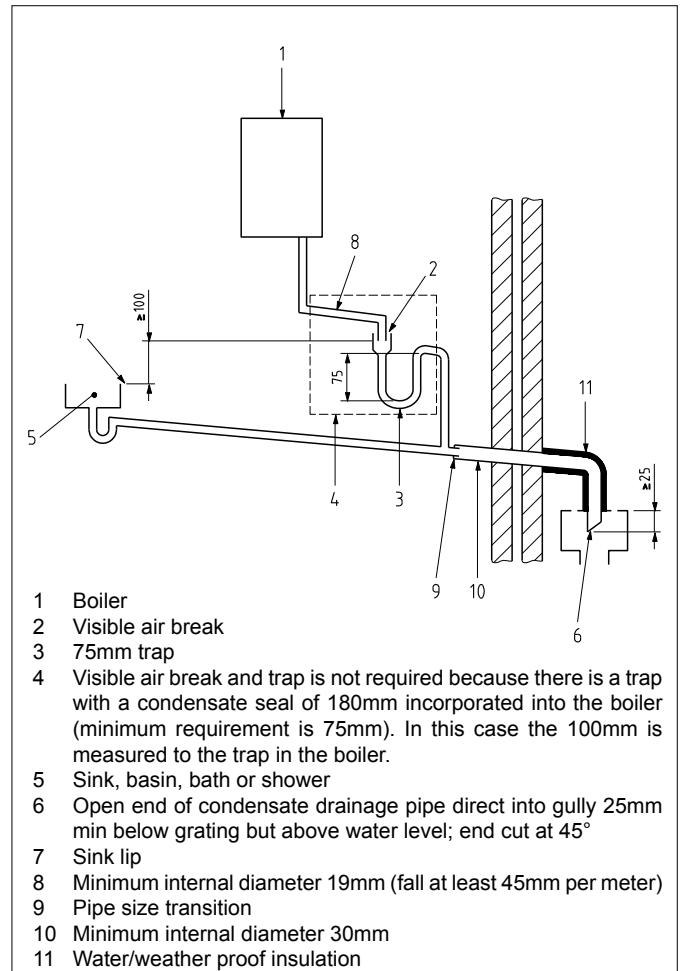

Drain requirements

Figure 9.7.2 (a)

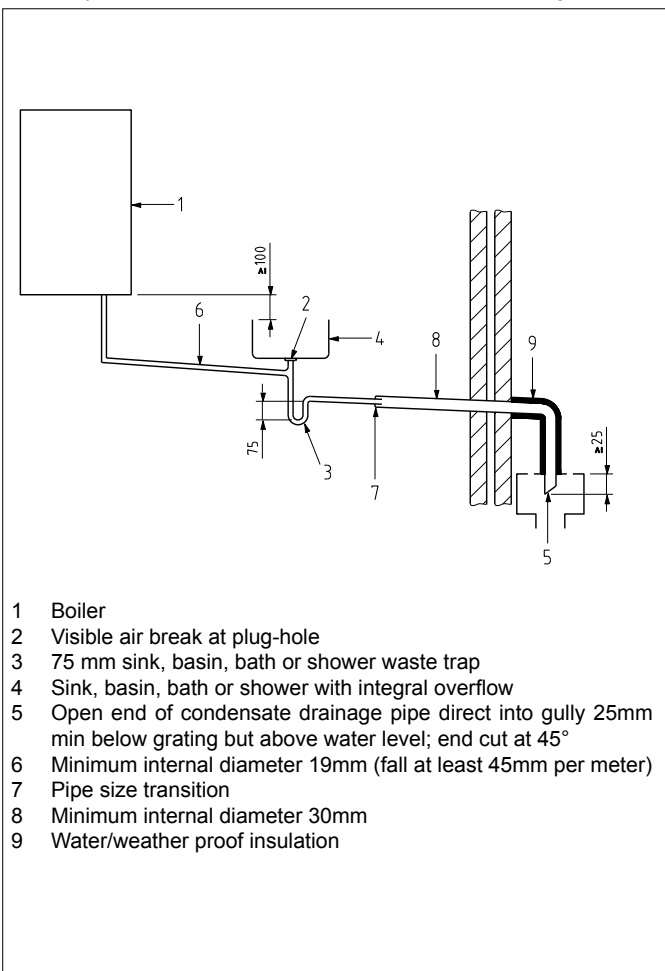

Drain requirements

Figure 9.7.2 (b)

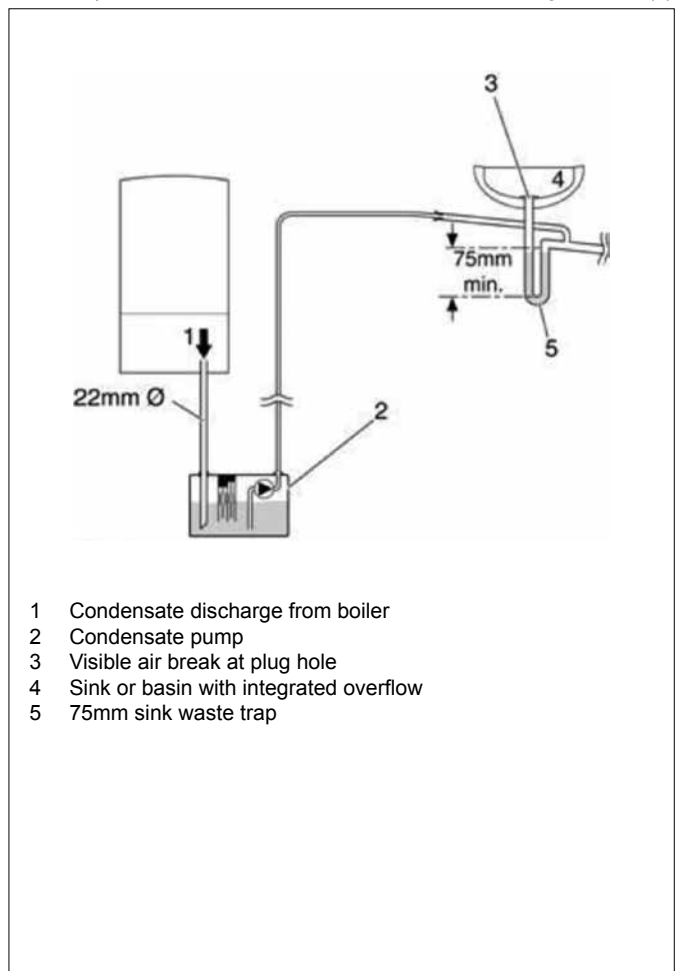

Drain requirements

Figure 9.7.3

### **External pipework**

The use of an externally-run condensate drainage pipe, terminating at a suitable foul water discharge point or purpose-designed soakaway, may also be considered; however if this termination method is chosen then the following measures should be adopted

- The pipe should be run internally as far as possible before going externally and the pipe diameter should be increased to a minimum of 30mm ID (typically 32mm OD) before it passes through the wall.
- The external run should be kept as short as possible, taking the most direct and "most vertical" route possible to the discharge point, with no horizontal sections in which condensate might collect. Do not exceed 3 metres outside the dwelling.
- The external pipe should be insulated using suitable waterproof and weatherproof insulation ("Class O" pipe insulation is suitable for this purpose) .
- The use of fittings, elbows etc should be kept to a minimum and any internal "burrs" on cut pipework should be removed so that the internal pipe section is as smooth as possible.

The customer/householder should be advised that even with the above measures this type of installation could freeze, and that if this were to occur then boiler shutdown could result, requiring remedial action - possibly involving a chargeable engineer call-out.

Where there are likely to be extremes of temperature or wind-chill, the use of a proprietary trace-heating system for external condensate drainage pipework, incorporating an external frost thermostat, should therefore be considered. If such a system is used then the installation instructions of the trace heating manufacturer and any specific recommendations regarding pipe diameter, insulation, etc. should be followed. All other relevant guidance on condensate drainage pipe installation should also be followed.

*Other cold weather protection methods approved or endorsed by boiler manufacturers and/or service organisations may be adopted if these are considered suitable by the parties involved.*

If an external soil/vent stack is used as the external termination then the connection method shown in Figure 9.6.4 should be used, together with the measures on insulation etc. as described above and shown in the diagram.

When a rain water downpipe is used as the termination (NB only permissible if this downpipe passes to a combined foul and rainwater drainage system) an air break must be installed between the condensate drainage pipe and the downpipe to avoid reverse flow of rainwater into the boiler should the downpipe itself become flooded or frozen. Figure 9.7.5 shows a suitable connection method.

Where the condensate drainage pipe is terminated over an open foul drain or gully, the pipe should terminate below the grating level, but above water level, in order to minimise "wind chill" at the open end. Pipe drainage will be improved if the end is cut at 45° as opposed to a straight cut. The use of a drain cover (such as those used to prevent blockage by leaves) may offer further protection from wind chill. Figure 9.7.6 shows a suitable connection method.

Where the condensate drain pipe terminates in a purpose-designed soakaway (see BS 6798:2009 or boiler installation manual for soakaway design requirements) any above-ground section of condensate drainage pipe should be run and insulated as described above. Figure 9.7.7 shows a suitable connection method.

### **Unheated internal areas:**

Internal condensate drainage pipes run in unheated areas such as lofts, basements and garages should be treated as external pipe.



**Draining of the condensation water to the external rain guttering is not permitted in view of the danger of freezing.**



**Before putting the boiler into operation fill the siphon with 150 ml of water.**

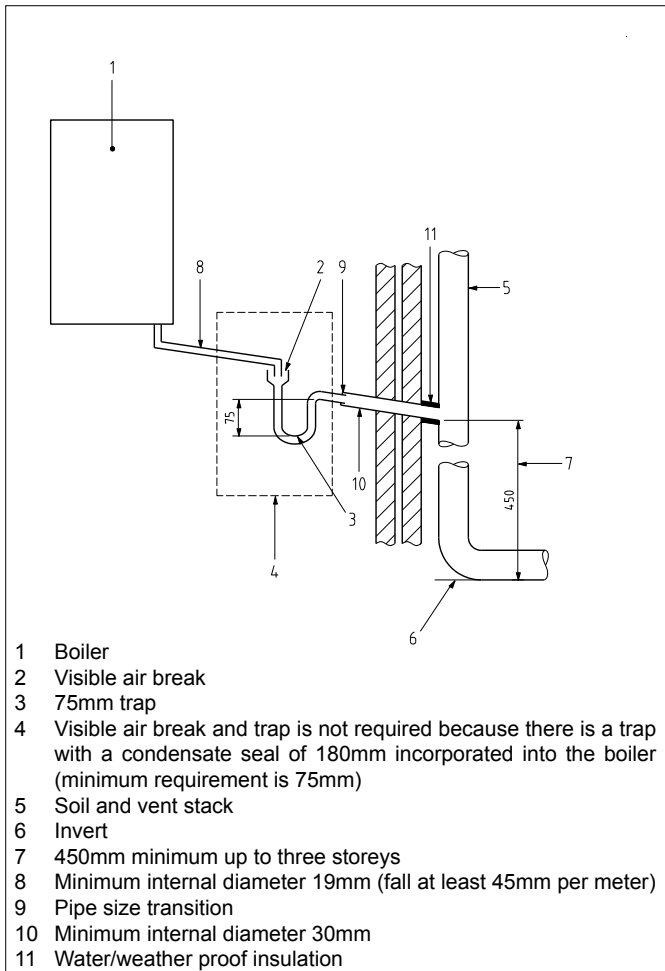

Drain requirements

Figure 9.7.4

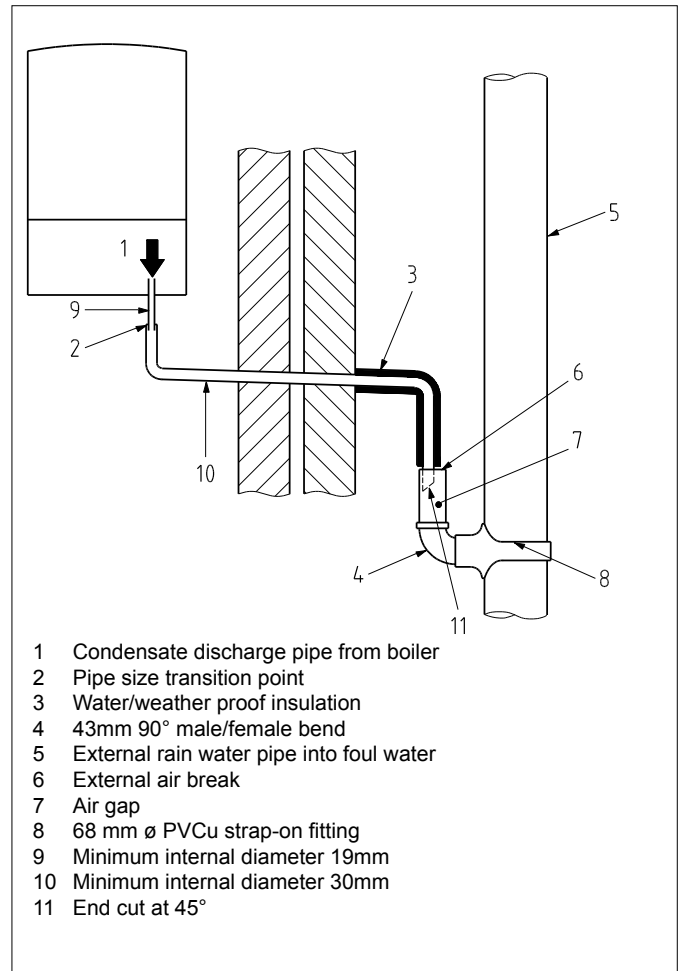

Drain requirements

Figure 9.7.5

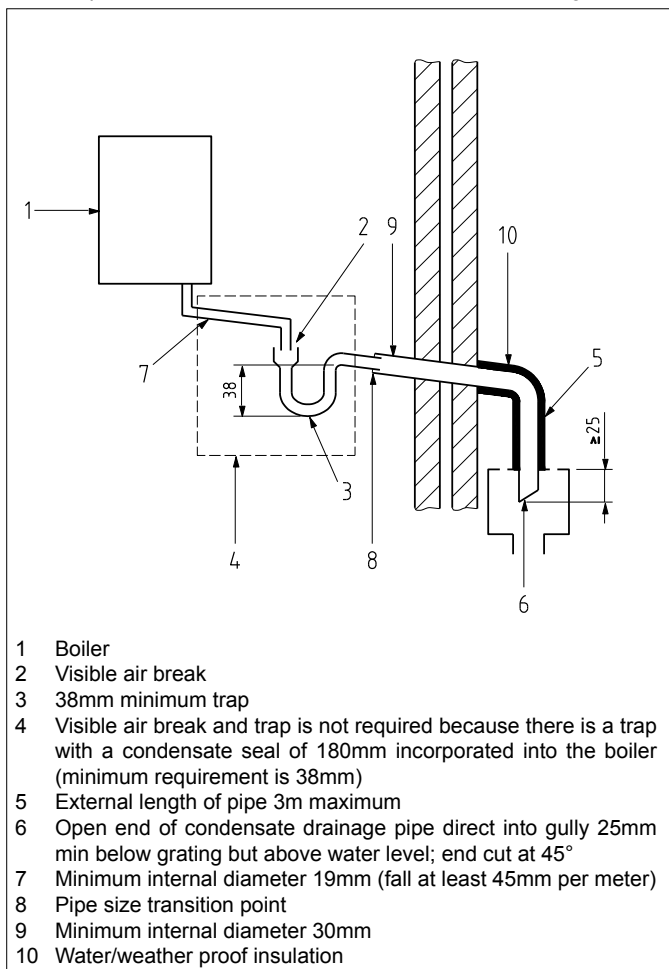

Drain requirements

Figure 9.7.6

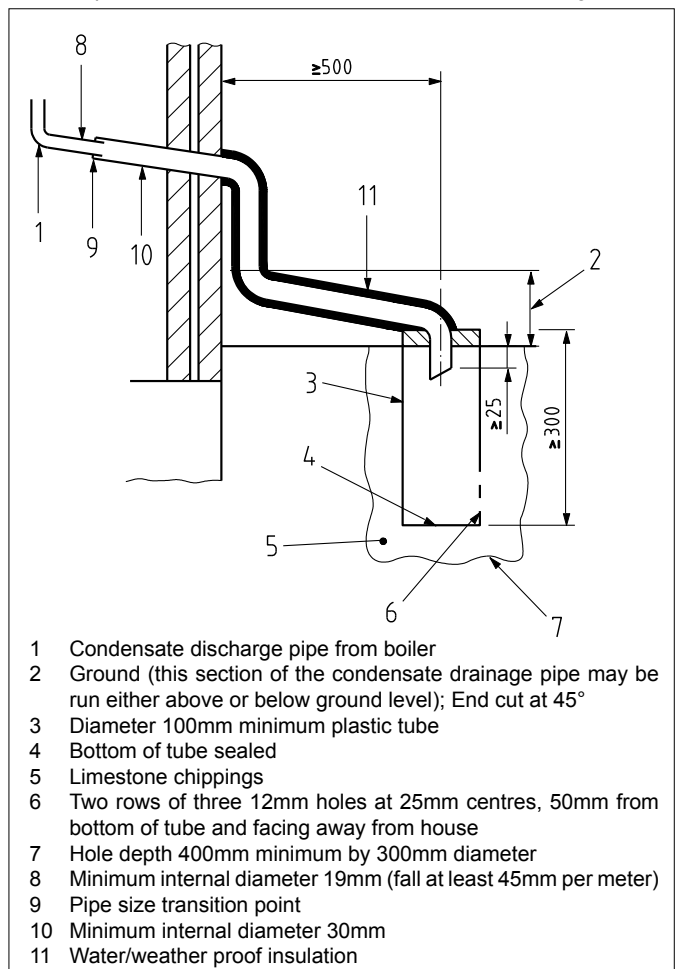

Drain requirements

Figure 9.7.7

## 9.8 Flue gas exhaust system

The flue gas exhaust system and air supply system consists of:

- Flue gas pipe;
- Air supply pipe;
- Roof or wall terminal.

The flue gas exhaust system and air supply system must comply with:

The flue gas outlet and air supply installation must comply with the current regulation requirements. IG UP 10 and BS 715.



**The ATAG iS boiler as described in this manual is NOT suitable for a combined flue system.**

The appliance concentric connection diameter is 60/100 mm, to which the flue gas outlet and air supply system can be fitted, with or without elbow pieces. The maximum permissible pipe length is set out in Table 9.8.2.a.

For further information about the available components of the flue gas and air supply system we recommend you consult the Flue system literature. Combinations with other brands or systems are, without written permission from ATAG Heating, not permitted.

The ATAG flue gas system is meant, and designed, solely for the use on ATAG central heating boilers adjusted to Nat gas or LPG. For this purpose the CE Certificate has been supplemented under the Gastec nr: 0063CQ3634 The maximum flue gas temperatures are below 70°C (full load 80/60°C).

The proper operation may be adversely influenced by changes of or adjustments to the correct set up. Possible warranty claims will not be honoured if incorrect changes result in non compliance with the installation manual or local rules and regulations.

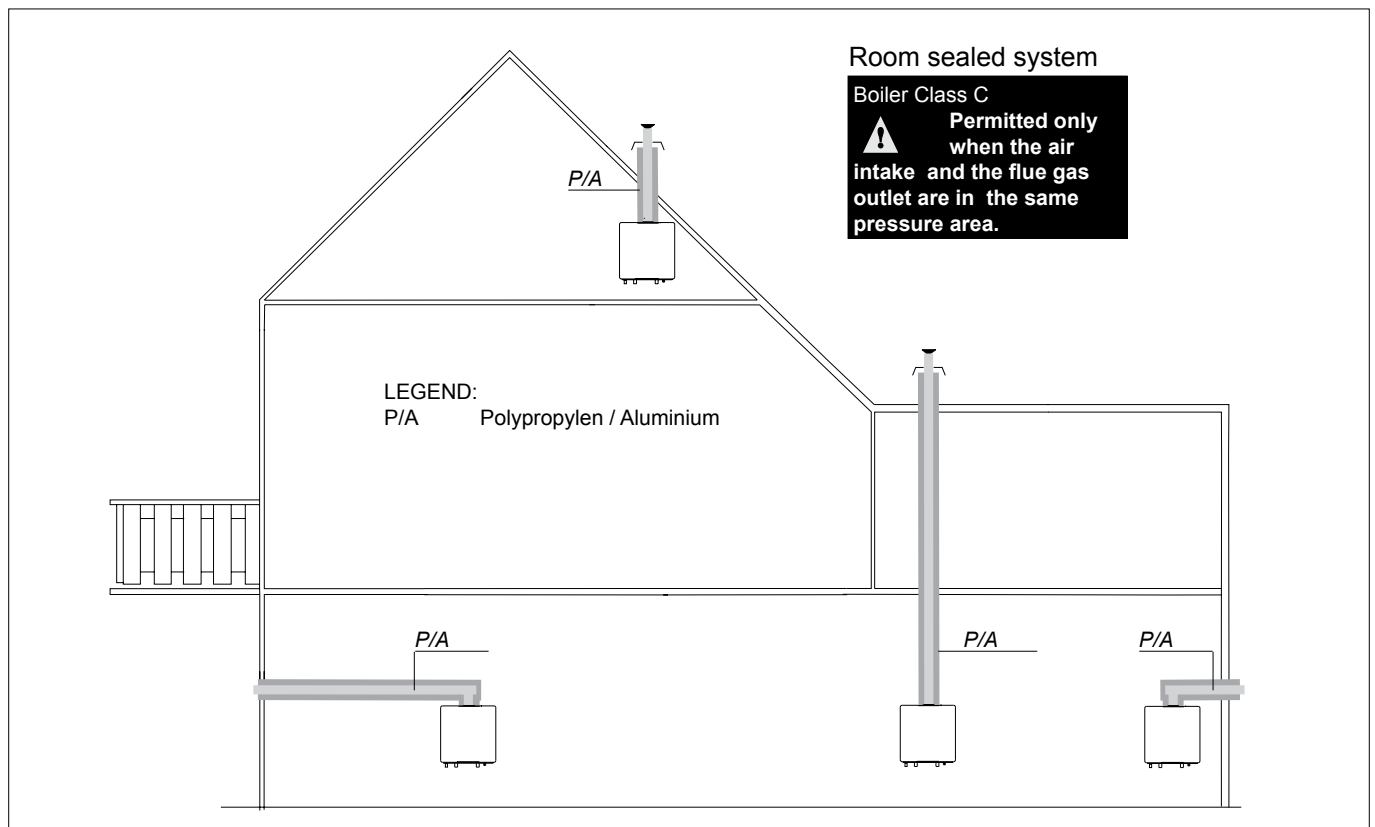

Room sealed system

Figure 9.8.a

## 9.8.1 Flue terminal locations

The terminal should be located where dispersal of combustion products is not unimpeded and with due regard for the damage or discolouration that might occur to parts of the building in the vicinity (see fig 9.8.1.a).

In certain weather conditions condensation may also accumulate on the outside of the air inlet pipe. Such conditions must be considered and where necessary insulation of the inlet pipe may be required. In cold and/or humid weather water vapour may condense on leaving the flue terminal. The effect of such 'plumeing' must be considered.

The terminal must not be located in a place where it is likely to cause a nuisance. For protection of combustibles, refer to IS 813 section 9.10.1. where the terminal is less than 2m (6.6ft) above a pavement or platform to which people have access (including) any balcony or flat roof. The terminal must be protected by a guard of durable material.

**⚠ Where a terminal is fitted below a window which is hinged at the top, and where the hinge axis is horizontal, and the window opens outwards, the terminal shall be 1m below the bottom of the window opening.**

**⚠ If the boiler is to be located under stairs, a smoke alarm meeting the requirements of I.S. 409 or equivalent must be fitted.**

**⚠ The flue must be terminated in a place not likely to cause a nuisance.**

For horizontal flue terminal direct to the rear or side through the wall (only 1 bend and 1 wall terminal) the terminal should be placed horizontal. The flue pipe inside the terminal is fitted in a 3 degrees angle to ensure the condensation water can run back to the boiler. See figure 9.8.1.a.

For longer horizontal sections, the outlet system should always be fitted on an incline ( $52 \text{ mm/m} = 3^\circ$ ) sloping down towards the boiler so that no condensation water is able to accumulate in the outlet system. The chances of icicles forming on the outlet is minimised by causing the condensation water to run back towards the boiler. See figure 9.8.1.b.

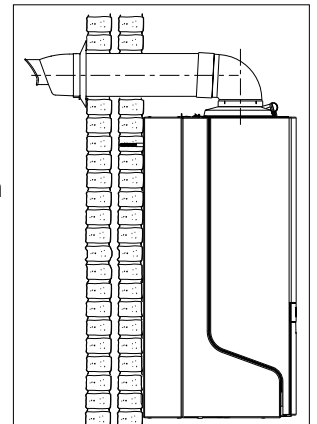

Figure 9.8.1.a

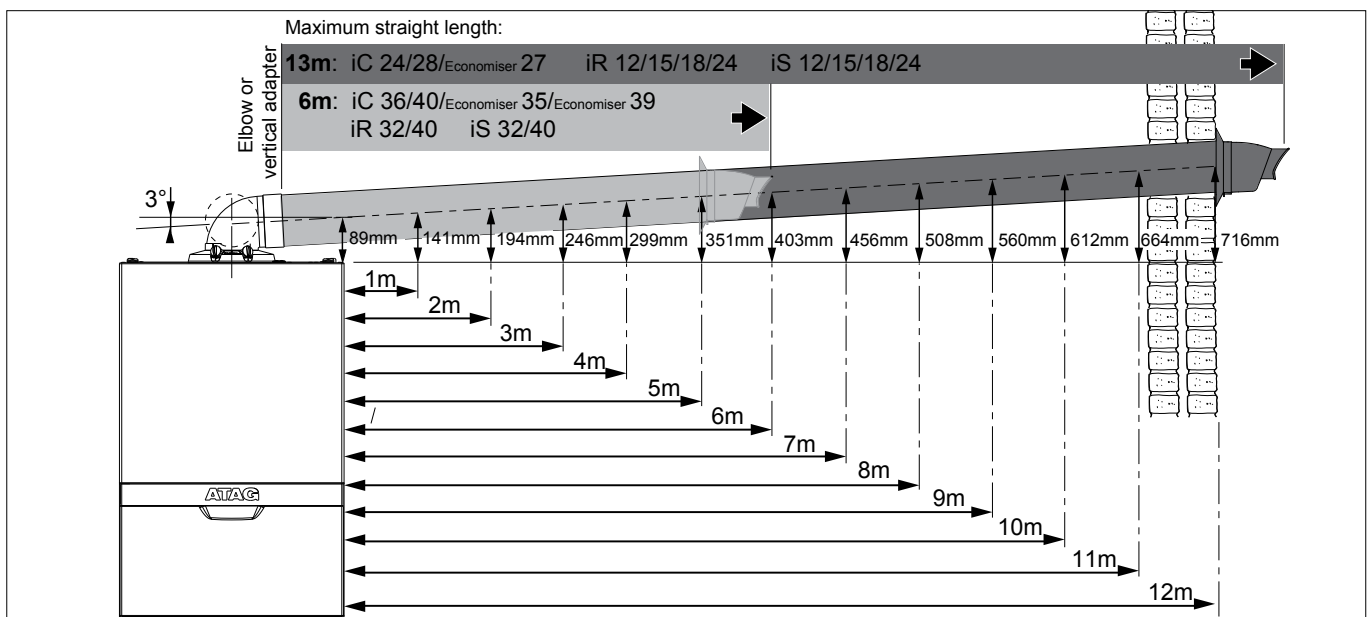

Figure 9.8.1.b

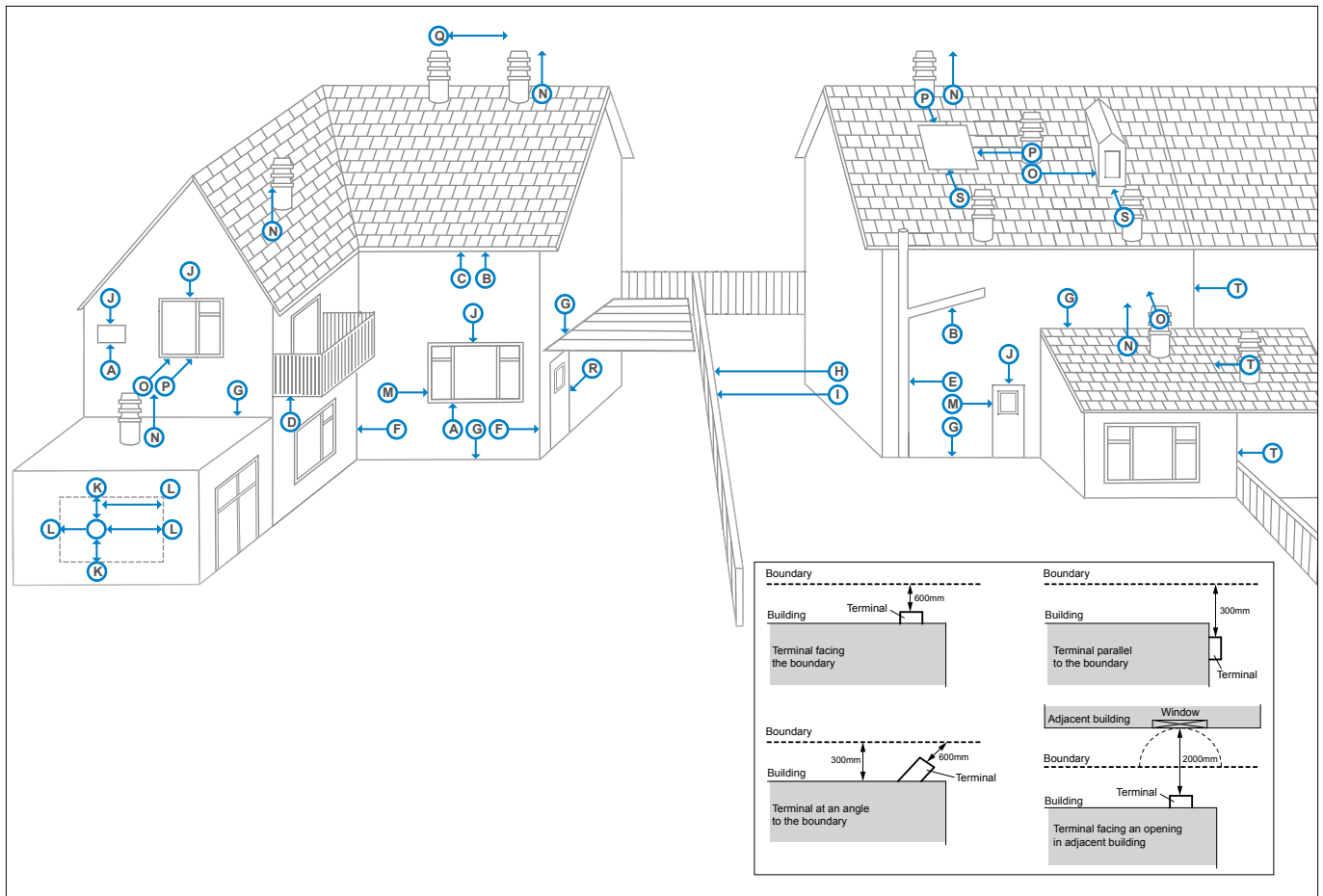

Figure 9.8.1.c

	Terminal position	Min. distance (mm)
A	Directly below an opening, air brick, windows, etc.	300 (See Note 1)
B	Below gutters, soil pipes or drain pipes	75 (See Note 3)
C	Below eaves	200 (See Note 3)
D	Below balconies	200 (See Note 3)
E	From a vertical drain pipe or soil pipe	150 (See Note 3)
F	From an internal or external corner	300 (See Note 2)
G	Above ground, roof or balcony level	300
H	From a surface or boundary facing the terminal	600 (See Note 4)
I	From a terminal facing the terminal	1200
J	Above an opening, air brick, window etc.	300 (See Note 1)
K	Vertically from a terminal on the same wall	1500
L	Horizontally from a terminal on the same wall	300
M	Horizontally from an opening, air brick, window etc.	300 (See Note 1)
N	Minimum protrusion through a roof	300
O	From a vertical obstruction	300
P	From an openable window	600
Q	From an adjacent vertical terminal	600
R	From an opening in the car port (e.g. door, window) into the dwelling	1200
S	Below a roof window	2000
T	Terminal parallel to a boundary	300

**Notes:**

- In addition, the terminal should not be nearer than 150mm to the framework of an opening into the building, i.e. a window surround or door surround.
- This clearance may be reduced to 25mm without effecting the performance of the boiler. However, to ensure the condensate plume does not affect adjacent surfaces a clearance of 300mm is preferable.
- These clearances may be reduced to 25mm without effecting the performance of the boiler. However, to ensure the condensate plume does not affect adjacent surfaces the terminal can be extended beyond gutters, pipes, eaves, balconies etc. by up to 500mm. If the flue is extended more than 500mm outside, it should be boxed and insulated.
- To reduce the possibility of nuisance to neighbouring buildings etc. it is recommended the terminal should not be less than 2500mm from car parking spaces, building boundary walls, fences etc.
- A terminal must not be sited under a car port roof.
- In certain weather conditions the terminal will emit a plume of steam. If possible avoid positioning the terminal where this may cause a nuisance, i.e. positions A, D, G, H, J or M.
- The flue terminal must be exposed to the external air and the position must allow the free passage of air across it at all times.
- A terminal must not be sited below 2m where people have access to, such as public footpaths, access routes, patios etc. However, if the terminal is fitted less than 2m above a surface where there is no public access, the terminal must be protected by a terminal guard.

The appliance produces a white wisp of condensate (plumeing). This wisp of condensation is harmless, but can be unattractive, particularly in the case of outlets in outside walls.

For wall terminals a plume management kit is available as an option (see fig. 9.7.1.d).

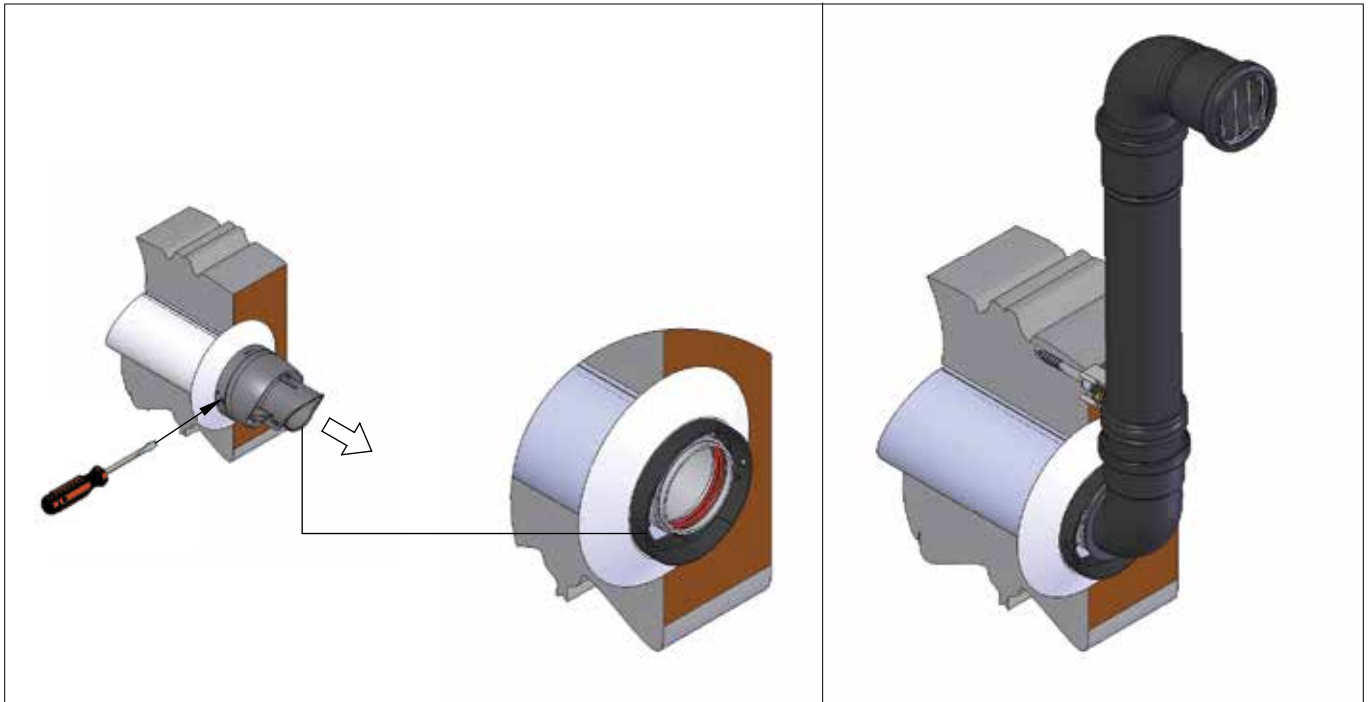

Plume management kit

Figure 9.8.1.d

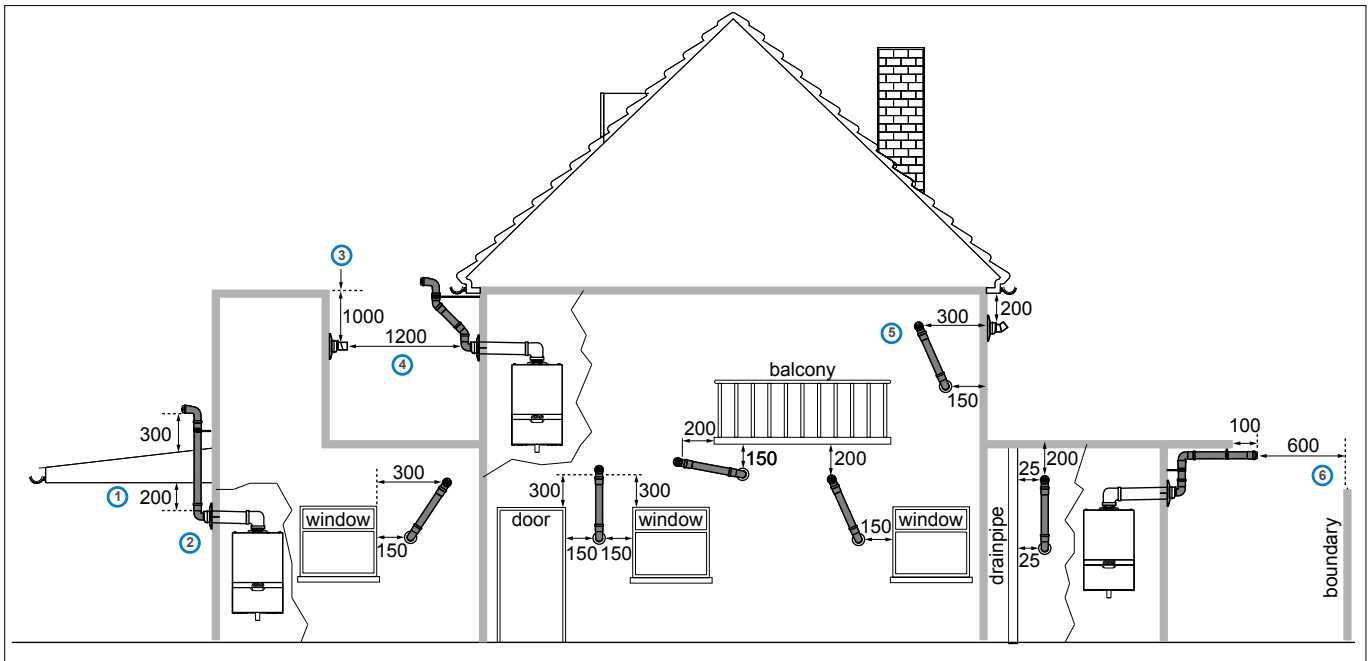

Figure 9.8.1.e

Terminal position Plume Management Kit (mm)	
1	Clearance no less than 200 mm from the lowest point of the balcony or overhang.
2	1,200 mm from an opening in a car port on the same wall i.e. door or window leading into dwelling.
3	The flue cannot be lower than 1,000 mm from the top of the light well due to the build up of combustion products.
4	1,200 mm between air intake and facing terminal.
5	Internal/external corners. The air intake clearance can be reduced to 150 mm providing the flue exhaust outlet has a 300 mm clearance.
6	600 mm distance to a boundary or surface facing a boundary, unless it will cause a nuisance. BS 5440: Part 1 recommends that care is taken when siting terminals in relation to boundaries.

**Notes:**

1. See also Notes on previous page.
2. Plume kits running horizontally must have a 10° fall back to the boiler for proper disposal of condensate.
3. For details on specific lengths see relevant chapter Dimensioning of the flue gas and air intake duct.
4. A terminal must not be sited under a car port roof.

## 9.8.2 Dimensioning of the flue gas and air intake duct

The total length of the run of the flue is determined by the flue diameter, including for the connection pipe, elbows fittings and terminal covers etc..

An incorrect dimensioned flue system can lead to disorders. Look at table 9.8.2.a for the choice of the boiler and the corresponding maximum flue length.

Explanation table 9.8.2.a:

Concentric flue gas system:

maximum noted length L = distance between boiler (from elbow or vertical adapter) and the end of terminal

When using bends the noted value behind every bend should be deducted from the maximum straight length.

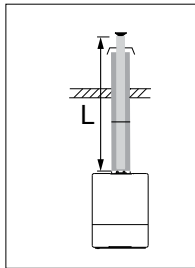

Example:

An iS24 with a concentric flue gas system  $\varnothing 60/100\text{mm}$  has according to the table a maximum flue straight length of 13m. In the system that is going to be put in there are 2 x 45° bends, so the maximum flue gas length is  $13 - (2 \times 1.0) = 11\text{ m}$ .

Concentric flue system $\varnothing 60/100\text{mm}$		
	$\varnothing 60/100\text{mm}$	L in m
iS 12 iS 15 iS 18 iS 24	Maximum straight length 60/100	13
	87° bend resistance length	1.6
	45° bend resistance length	1.0
iS 32 iS 40	Maximum straight length 60/100	6
	87° bend resistance length	1.6
	45° bend resistance length	1.0

Dimensions flue gas system and air supply system

Table 9.8.2.a

### Flue dimensions

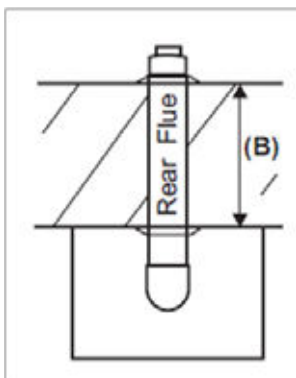

Rear Flue	B (mm)	
	Min	Max
Telescopic flue (FA100100)	280	430

Side Flue	B + C (mm)	
	Min	Max
Telescopic flue (FA100100)	285	435

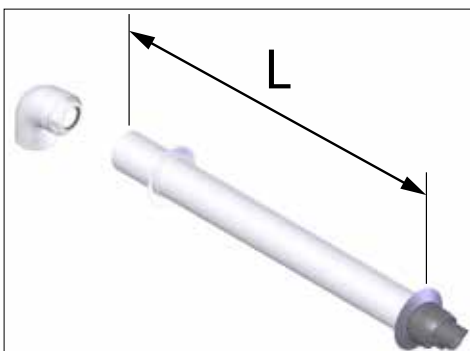
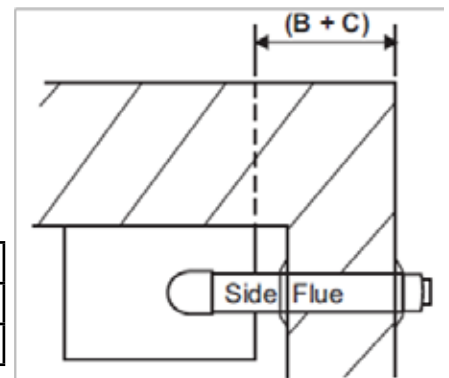

Rear Flue

$L = \text{wall thickness (B)} + 150\text{mm}$

Side Flue

$L = \text{wall thickness (B)} + \text{distance between boiler and wall (C)} + 150\text{mm}$

If the length L is more than 580mm rear flue or 585mm side flue, then a Horizontal flue fixed length 1000mm ( $\varnothing 60/100\text{mm}$ ) with lock function elbow (FA100250) will need to be used instead, up to 810mm.

Figure 9.8.2.a

## Fitting the flue

**Note:** If it is required to cut an extension, **DO NOT** cut the end of the inner duct that incorporates the seal joint.

Ensure the inner duct end without the seal joint is cut so that it is flush with the outer duct.

Ensure that all cuts are square and free from burrs.

Once assembled with the components pushed home, the flue is fully sealed.

1. Adjust the telescopic flue and secure with sealing tape supplied or cut the fixed length terminal flue to the required length.
2. Fit the flue to the extensions (if required) by locating the inner duct into the seal joint and push fully home the inner and outer duct.
3. When connecting the horizontal flue terminal length ensure the terminal end outlet is at the uppermost part of the flue.
4. Pass the terminal flue assembly through the wall.
5. Fit the bend to the boiler and rotate to the correct position and secure in position.
6. If the inside sealing collar (white) is being used to make good the inside wall, then it will need to be fitted before assembling the flue.
7. Pull the flue assembly towards the bend, locating the inner duct into the seal joint on the bend and secure the flue assembly to the bend by pushing fully home.
8. Make good the outside wall by fitting the outside sealing collar (grey) onto the location provided immediately behind the flue terminal grille. Make good the inside wall using the inside sealing collar (white) if required.

When mounting the flue gas system, pay attention to the flow direction (See figure 9.8.2.b). It is not permitted to mount a system upside down and will lead to complaints.

Use a soap solvent or special grease (supplied in the accessory bag with the boiler) to simplify the fitting.

The ATAG flue system used is a push fit flue system, which **does not** require screws to be fitted at each flue joint.

The flue system must be adequately supported at regular intervals between brackets of no more than 1.0 metres for horizontal sections and no more than 2.0 metres for vertical sections.

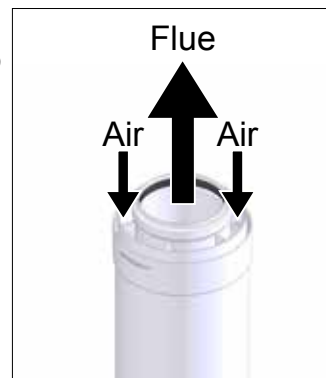

Flow direction

Figure 9.8.2.b

## 9.9 Fitting the boiler onto the boiler frame

After the pipe work of gas, heating installation has been fitted to the boiler frame, the boiler can be placed on the boiler frame.

Before hanging the boiler to the boiler frame remove first the cover of the boiler first. The cover is also the air cabinet and is attached to the boiler case with 2 fasteners (A and B) (see figure 9.9.a).



**Note that there is an earth cable to disconnect when removing the cover from the boiler. Free space for removing the connector is 400mm. Remember to connect this earth cable when replacing the cover.**



**Always secure the fasteners with the screws (A and B) after replacing the cover.**

Remove furthermore the 4 plastic caps from the boiler connections.



**When removing the plastic sealing caps from the pipes, contaminated testing water may be released.**



**Lift the boiler only by the boilers case.**

### Lifting and carrying precautions:

- Lift only a manageable weight, or ask for help.
- When lifting the boiler, bend the knees, and keep the back straight and feet apart.
- Do not lift and twist at the same time.
- Lift and carry the boiler close to the body.
- Wear protective clothing and gloves to protect from any sharp edges.

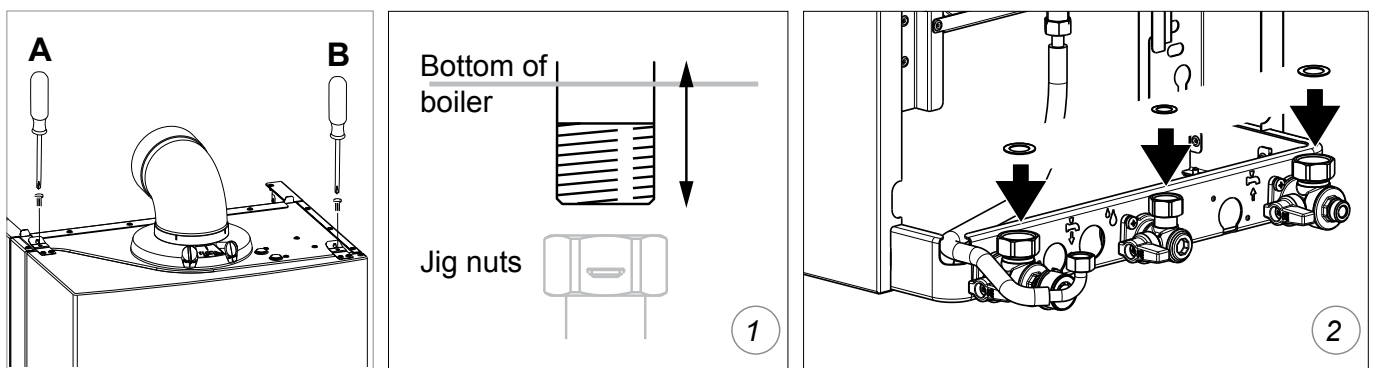

Figure 9.9.a

1. Press all connection underneath the boiler upwards
2. Put on each valve and the elbow fitting a fibre washer (supplied)

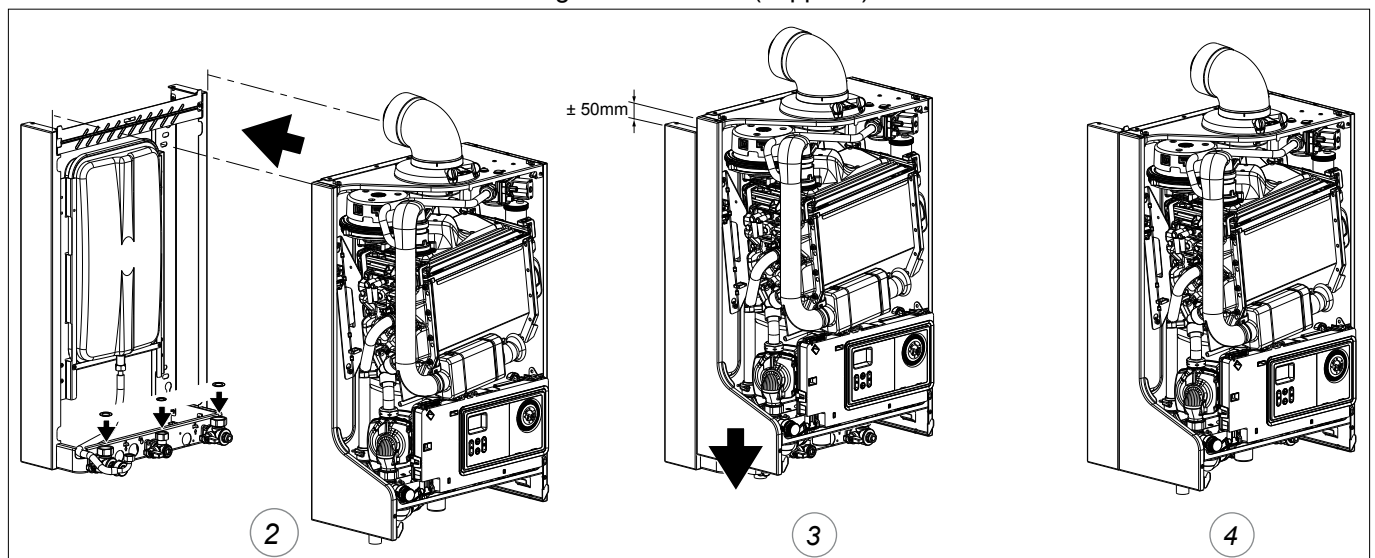

Figure 9.9.b

- 3 and 4. Take the boiler and hang it from approx. 50mm higher than the boiler frame vertical downwards on the boiler frame so the fittings will be axial approached.



Figure 9.9.c

**Fitting the nuts:**

Turn each nut of the fittings on the boiler connections by hand and tighten each nut with a wrench. Note: 1/2" with 25Nm and 3/4" with 40Nm.

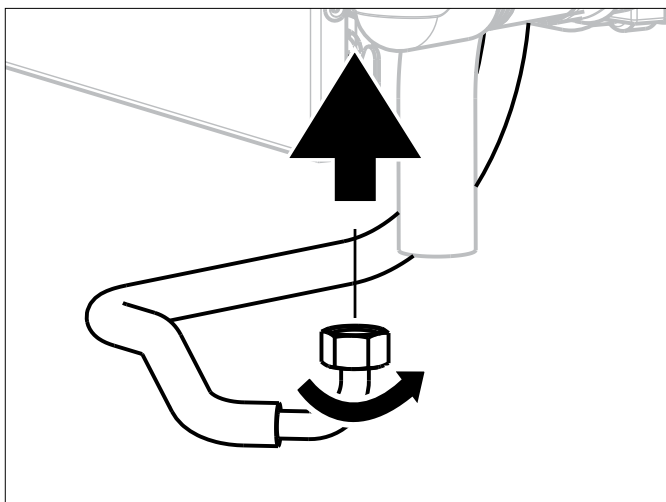
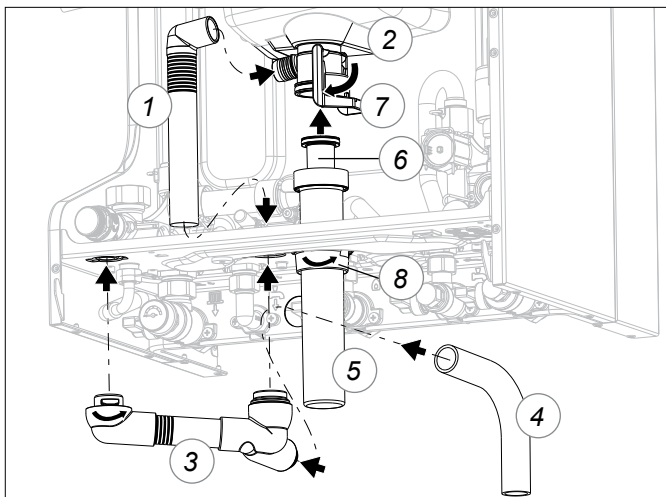

Figure 9.9.d

**Fitting expansion vessel hose:**

Take the end of the flexible expansion vessel hose and fit it to the 3/8" boiler's expansion vessel connection using a fibre washer.



**Note:**  
Pressure relief valve outlet is combined with condensate outlet.

Figure 9.9.e

**Fitting siphon:**

- Press and turn the assembly (3), with the elbow first, in the corresponding holes in the bottom plate of the boiler.
- Press the black rubber elbow with flexible drain pipe (1) on the condensate tray (2)
- Press the black flexible pipe (1) from inside the boiler in the rubber T-piece (3).
- Lead the long black flexible pipe (4) through the free hole of the boiler frame and press it in the T-piece (3)
- Lead the other end of the flexible pipe outside the boiler to the drain as installed according to chapter 9.7.
- Fill the siphon cup (5) with **150 ml water**, insert the siphon pipe (6) in the siphon cup (do not press) and insert this through the hole in the bottom plate of the boiler into the condensate tray (2) of the heat exchanger without any force. Secure the siphon cup with the securing clip (7) by turning it clockwise (click!).
- Press the sealing ring (8) around the siphon cup and press/turn it in the bottom plate of the boiler.



**Before putting the boiler into operation fill the siphon with 150 ml of water.**

## 10 Electrical connection

The appliance complies with the actual directives. The installation must continue to comply with:

- A 230V -50Hz mains electrical supply is required fused externally at 3A.
- A deviation on the grid of 230V (+10% or -15%) and 50Hz
- the national rules for electrical installations.

The appliance must be connected to an earthed socket. This must be visible and within reach.

The following general stipulations also apply:

- No changes may be made to the wiring of the appliance;
- All connections should be designed in accordance with the enclosed regulations;
- Should it be necessary to change it, the mains power supply cable may only be replaced with an ATAG mains power supply cable.

The connection terminals are positioned at the back of the control unit:

- Press handle A slightly to the left (see fig. 10.a)
- Turn the control unit downwards.

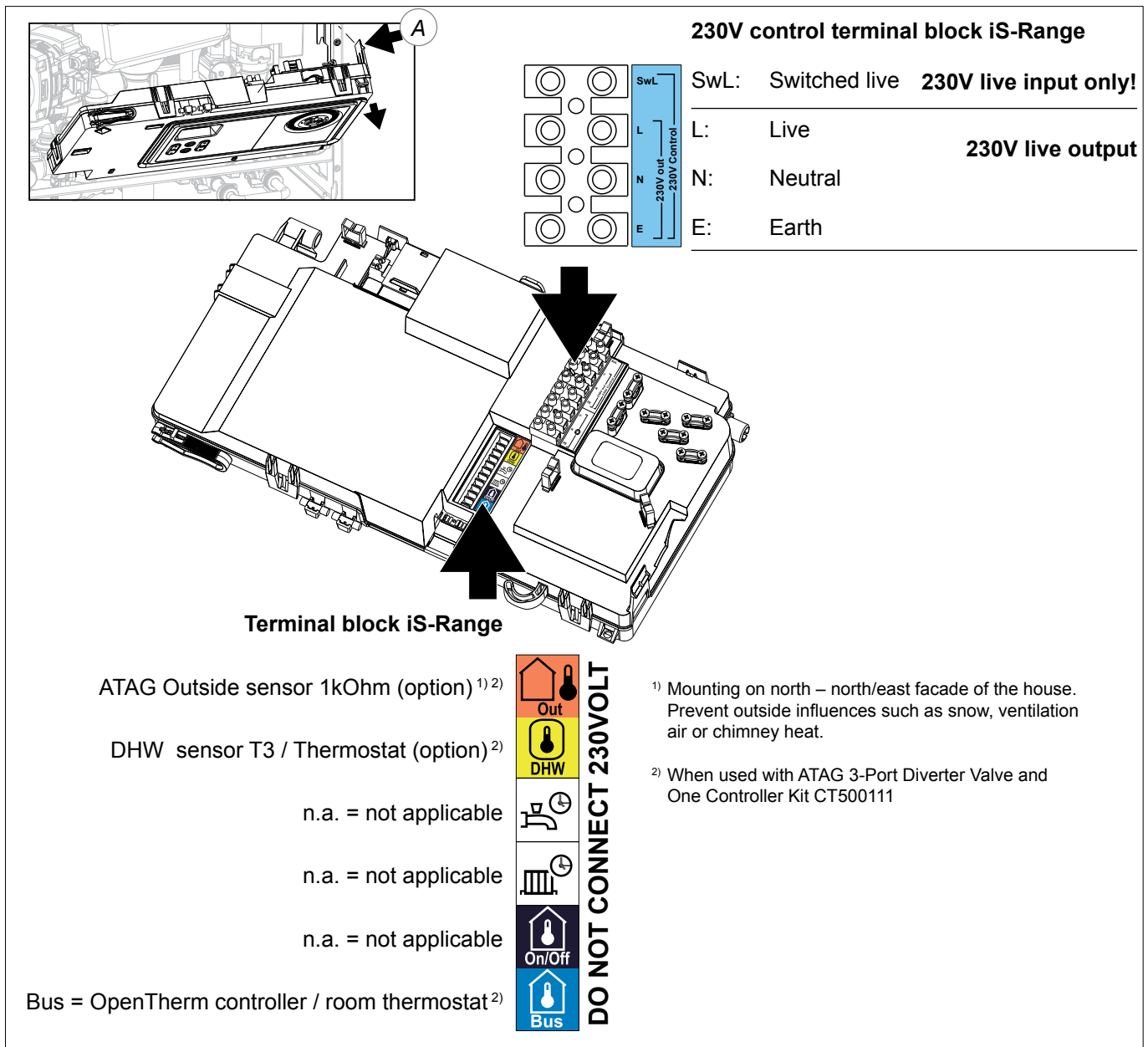

terminal block

Figure 10.a

## 10.1 One controller & connections

Connected to the ATAG boiler there can be 3-Port Diverter Valve and One Controller Kit:

A.	For optimal use of the boilers control ATAG advises:	
	Position Bus:	ATAG One Wifi thermostat.

For more detailed questions about components that have not been supplied by ATAG, contact the vendor concerned.

## 10.2 Weather compensation & connections

When a weather compensation sensor (optional accessory) is used the two wires from the sensor connect to the orange volt free outside sensor connector position. See figure 10a.

This can only be used with the 3-port Diverter Valve and One Controller Kit.

# 10.3 Electrical diagram

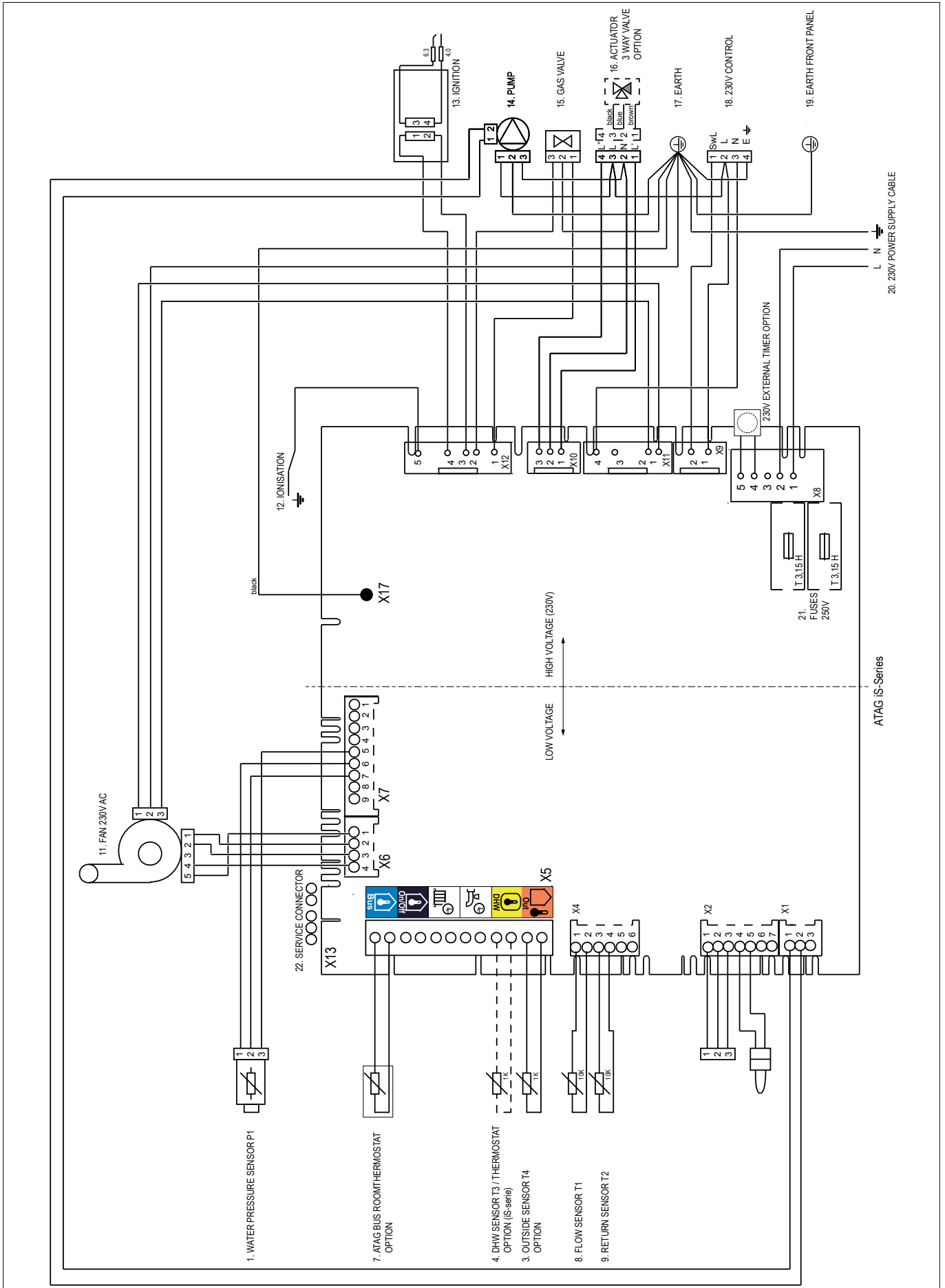

Figure 10.1.a

## 11 Filling system

The central heating installation needs to be filled with potable water according to the requirements in chapter 9.3 'Water quality'. For filling or topping up the heating system the installation must be provided with a filling loop or a fill and drain valve to connect a garden hose i.e.. Use the filling loop according to the following procedure:

1	Attach the filling loop pipe to the filling loop assembly;
2	Open the filling loop valves;
3	Slowly fill the central heating system up to 1.2 – 1.5 bar; (at the bottom left a pressure gauge indicates the water pressure in the central heating system)
4	Close the filling loop valves;
5	Vent the entire heating installation starting at the lowest point;
6	Check the water pressure and top up if necessary to 1.2 – 1.5 bar;
7	Check the filling loop valve is closed;

When powering up the boiler (described in chapter 13) an automatic de-aeration program will run to vent the boiler. During this program the pressure in the central heating needs to be checked, and when necessary, topped up again.



**It may take some time before all the air has disappeared from a filled installation. Certainly during the first week sounds may be audible that indicate air. The automatic air vent in the boiler will let this air escape, causing the water pressure to drop during this period and water will need to be refilled again.**



**Always remove the filling loop pipe or garden hose after filling or topping up the heating system and close the connections with a cap nut.**

## 12 Boiler controls

Before the electrical power is switched on, it helps to know the operation of the boiler in advance. On this page the controls are described in short. The next page describes the button functions and the symbols on the display.

The boiler is equipped with self-managing control system. This control system takes over a large part of the manual settings, which simplifies the start-up of the installation considerably.

After filling the installation and switching on the electrical power supply a short start-up program is activated. This shows all digits, boiler type and software version and the automatic de-aeration program is activated. The automatic de-aeration program lasts for approx. 7 minutes and stops automatically. Then the boiler will switch on for the enabled program (See chapter 11 'Filling and bleeding boiler and installation').

### CH controls

With a demand from the heating controls, the boiler activates its 1 minute delay period. This is to prevent the heat exchanger from losing its heat too quickly in the event of a hot water demand. Then the pump starts and after 30 seconds the gradient control becomes active. The starting point of the gradient control is the currently existing flow temperature. A Delta-T control (25K) ensures a stable control according to heat request.

If the flow temperature is below the T-set value of 20°C the boiler will immediately start.

If during a demand from the heating the burner switches off, because the desired flow temperature is exceeded, there will be an anti-cycle time in operation for 5 minutes.

This means that the burner switches on again after 5 minutes if there is still a demand from the heating.

**Resistance table sensors ATAG iC-, iS- and iR-series**

NTC1k (25°C)		NTC10k (25°C)	
Temperature [°C]	Resistance [Ohm]	Temperature [°C]	Resistance [Ohm]
-10	4.574	-10	55.047
-9	4.358	0	32.555
-8	4.152	10	19.873
-7	3.958	12	18.069
-6	3.774	14	16.447
-5	3.600	16	14.988
-4	3.435	18	13.674
-3	3.279	20	12.488
-2	3.131	22	11.417
-1	2.990	24	10.449
0	2.857	26	9.573
1	2.730	28	8.779
2	2.610	30	8.059
3	2.496	32	7.406
4	2.387	34	6.811
5	2.284	36	6.271
6	2.186	38	5.779
7	2.093	40	5.330
8	2.004	42	4.921
9	1.920	44	4.547
10	1.840	46	4.205
11	1.763	48	3.892
12	1.690	50	3.605
13	1.621	52	3.343
14	1.555	54	3.102
15	1.492	56	2.880
16	1.433	58	2.677
17	1.375	60	2.490
18	1.320	62	2.318
19	1.268	64	2.159
20	1.218	66	2.013
21	1.170	68	1.878
22	1.125	70	1.753
23	1.081	72	1.638
24	1.040	74	1.531
25	1.000	76	1.433
26	962	78	1.341
27	926	80	1.256
28	892	82	1.178
29	858	84	1.105
30	827	86	1.037
35	687	88	974
40	575	90	915

The ATAG iS is equipped with boiler sensors of 10kOhm. The resistance value and corresponding temperature are shown in the accompanying table.

## 12.1 Controls and explanation of the functions

### Central heating

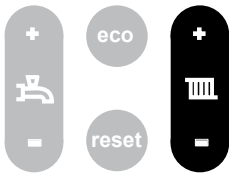

Setting the CH water temperature:

Briefly press + or – ; the display will show the flashing preset value;

Briefly press + or – to change the set value. Each change becomes active directly.

CH program OFF: Press – until the lowest value is reached and then press – again. The display is showing - - .

Switching on works in reverse order.

### Boiler information

Requesting current data:

Briefly press the eco-button for 6 seconds in order to obtain the following value using the scroll buttons:

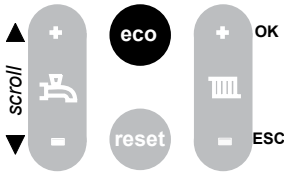

A0	Flow water temperature
A1	Return water temperature
A2	DHW temperature (only with 3 port diverter kit)
A3	T-set temperature (calculated)
A4	Flue gas temperature (only if a flue gas sensor is connected)
A5	Outside temperature (only if an outside sensor is connected)
A6	Water pressure
A7	n.a.
A8	Ionisation current in $\mu\text{A}$ .
A9	rpm of fan (x100)

To return to the standard view press ESC.

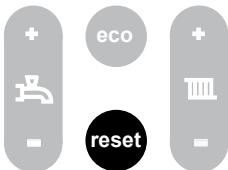

### Reset button

The reset button allows the boiler to restart if an error has occurred.

In case of an error the symbol is displayed with a XXX code.

In other cases the Reset button does not function and will not respond to operation.

See chapter 17 for a brief overview of codes.

### Ancillary functions:

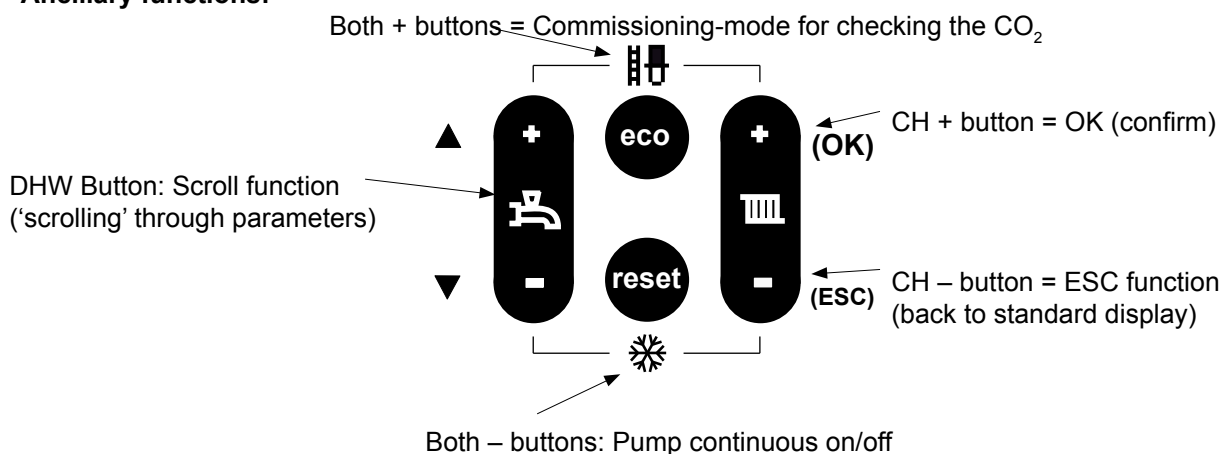

## 13 Commissioning the boiler

Make sure before the boiler is put into operation that the boiler and installation have been fully vented. Vent the gas line and open the gas isolation valve to the boiler. The boiler requires no adjustment of the burner pressure and quantity, because it is self-regulatory and has been set in the factory and should not be reset.

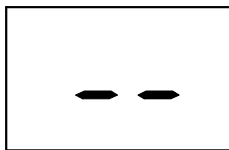

1. Turn on the boiler electrical supply;
2. When the boiler starts up for the first time the following will be shown:

-- (power on)

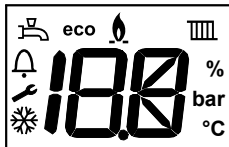

All digits (segment test)



0 (parameter 9: from factory 0)  
 1 (boilertype: parameter 8)  
 03 followed by 03 (software version part 1 and software version part 2)



3. The code 105 appears on the display; The 7 minute de-aeration cycle starts;
4. Vent the entire heating installation starting at the lowest point;
5. Check the water pressure and top up if necessary to 1.2 – 1.5 bar;
6. Check the filling loop if it is closed;

### Waterpressure

The iS boiler is supplied with a pressure sensor. This sensor control has following settings:

- 0.7 bar: below this pressure the burner is blocked for operation
- 0.7 to 1.0 bar: boiler output reduced to 80%
- 1.0 to 3.0 bar: boiler fully functional
- 3.0 bar: above this pressure the boiler is blocked for operation.

Next to this the pressure sensor is used to set the boiler free before every start. Before the burner is set free the boiler does a pump check, it checks for an increase in pressure when the pump starts. If there is an increase of water pressure, the boiler will fire up. If there is no increase the burner is blocked.

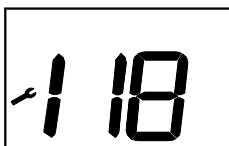

If the water pressure drops below 1.0 bar code 118 will appear in the display; This will disappear again the moment the water pressure is higher than 1.3 bar and the de-aeration program will start (code 105).

This will take approx. 7 minutes and will be followed by the default display (OK).



The boiler is stand by now for heating.

## a CH system



The CH program is always active after start-up.

This is indicated by the upper radiator icon.

If there is heat request, it is indicated by a flashing radiator icon and the heating will be put into operation with a flame icon.

The circulation pump will switch on and the boiler will switch on after 1 to 2 minutes.

When there is no more heat requested the radiator symbol may be solid or flashing, but the flame symbol will disappear. The pump will continue to run due to the pump over run feature (overrun time confirmed in technical specification table page 7).

## b Pump function

By default the boiler is set in such a manner that the pump will switch on in case of a heat request for CH or DHW. Switching on and off is managed entirely by the control system.

### Danger of frost



If there is danger of frost damage to the CH installation, it is advisable to let the pump run continuously.

By pressing both - buttons at the same time for 8 seconds the pump can be switched on continuously.

If the pump is set to continuously this is displayed by a snowflake icon.

### Boiler frost protection

If the (T1) flow sensor registers a temperature of 5°C or below in the boiler, the boiler will fire up. The boiler keeps on firing until the temperature reaches 10°C (measured on the flow sensor) and the boiler switches off again.

In this mode the snowflake icon will flash.

## 13.1 Settings

When the boiler is installed, it is in principle ready to be put into service. Most settings of the control system are already programmed from factory. Only parameter P0 (kind of heating installation) has to be checked and set, if necessary, to adjust the boiler to the connected installation.

To change this setting, proceed as follows:

1. Press the OK button for 3 seconds.  
*The display shows 'P0';*
2. Press the OK button for 3 seconds again.  
*The display shows 'on' shortly followed by 'P0';*
3. Press the OK button to enter P0;
4. Choose one of the following options by using the left + and - button (DHW symbol);
  1. CH Tmax: 85°C; Gradient: 5; Heating line 24
  2. CH Tmax: 70°C; Gradient: 5; Heating line 19
  3. CH Tmax: 60°C; Gradient: 4; Heating line 15
  4. CH Tmax: 50°C; Gradient: 3; Heating line 11
5. Press the OK button to confirm your choice;

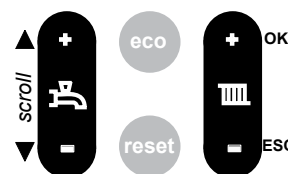

*When you want to change more settings proceed with step 6:*

*When you are ready press the ESC button until the default display is shown again.*

6. Press the Scroll button to select another parameter;
7. Press the OK button if you want to change the selected parameter;
8. Adjust the value if desired / possible with the + or - button (DHW button)
9. Briefly press the OK button to confirm the new setting.

*The display shows the selected parameter again*

7. Press the ESC button until the default display is shown again:

*If during 8 minutes no button is used, the default display is automatically shown on the screen.*

## 13.2 Parameter chapter

Par.	Factory setting	Description	Range
P0	1	1. CH Tmax: 85°C; Gradient: 5; Heating line 24 2. CH Tmax: 70°C; Gradient: 5; Heating line 19 3. CH Tmax: 60°C; Gradient: 4; Heating line 15 4. CH Tmax: 50°C; Gradient: 3; Heating line 11	<b>Check and change, if necessary, this parameter before taking the boiler into operation.</b>
P1	max	Maximum power CH in % <i>Can only be reduced. 0 = low load</i>	0 - max
P2	max	Pump, max. percentage	XX - 100%
P3	min	Pump, min. percentage	min - XX / XX*
P4	0%	Correction factor fan speed. <b>Do not change!</b>	
P5	5	Gradient speed CH	0 - 15 (0=off)
P6	24	Heating line CH-water temperature (see also heating line graph)	1 - 30
P7	25	Summer-Eco temperature <b>N.A.</b>	8 - 30
P8	1	Boiler type. <b>Do not change!</b> <i>1 = Natural gas fired boiler, 2 = Boiler with flue non-return valve, 3 = Propane gas fired boiler</i>	1-3
P9	0	Service-parameter. <b>Do not change!</b>	

\* Depending of connected type of boiler control

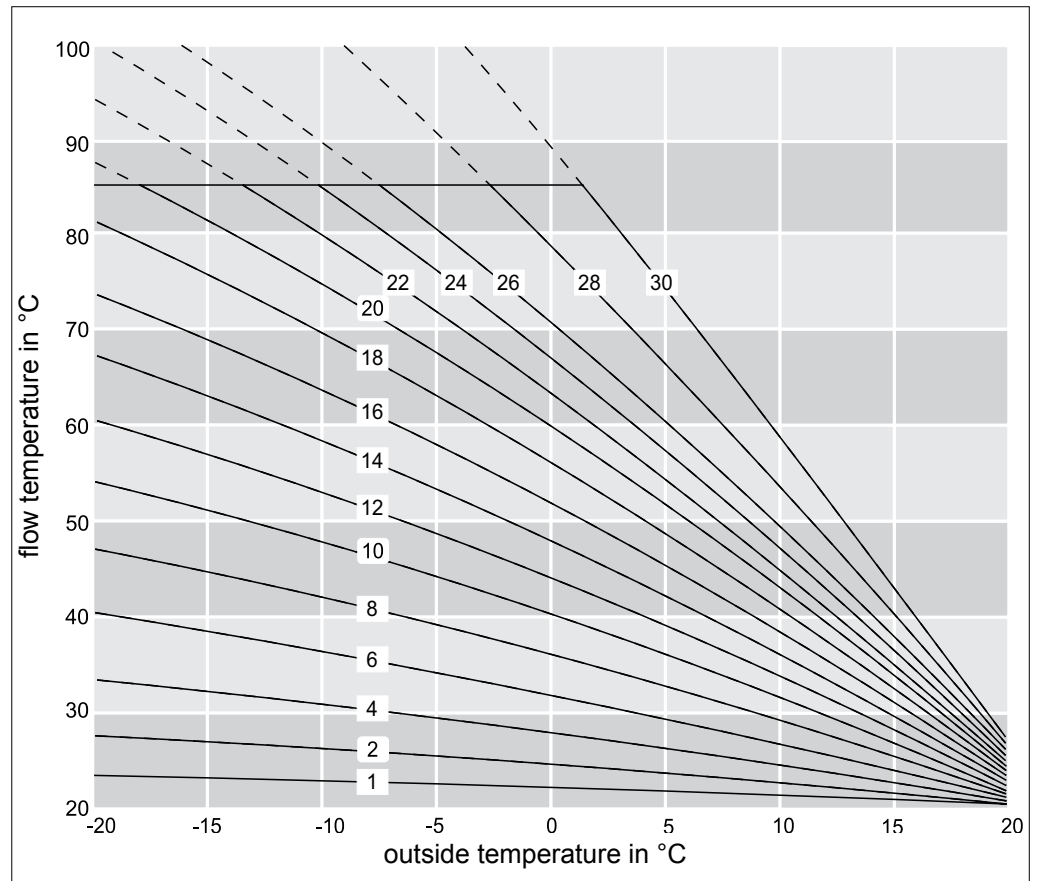

heating line

Graph 11.4.a

## 14 Isolating the boiler

In some situations it may happen that the entire boiler has to be deactivated. With the function button for the CH program the boiler is put out of service.

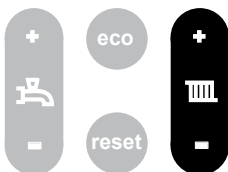

CH program OFF: Press – until the lowest value is reached and then press – again. The display is showing -- and the upper is off.

Switching on with the + button takes place in reverse order.

ATAG recommends to leave the electrical power supply on, so that the circulation pump and the three-way valve are activated automatically once every 24 hours in order to prevent jamming.



**If there is danger of frost it is advisable in this case to drain the boiler and/or installation.**

## 15 Commissioning

- !** Work on the installation and/or boiler should only be carried out by qualified personnel with calibrated equipment.
- !** At the time of commissioning, complete all relevant sections of the Benchmark Checklist located on the inside back pages of the document.

For maintenance of the boiler the cover has to be removed.

Unscrew the 2 locking screws from the fasteners at the top of the boiler, unlock the fasteners and remove the cover in a forward motion. See figure 16.a

- !** Note that there is an earth cable to disconnect when removing the boiler front panel. Free space for removing the connector is about 400 mm. Remember to connect this earth cable when placing back the boiler front panel and take care the wire does not get stuck between front panel and boiler.

Changing settings, such as the burner pressure and the amount of air flow, is superfluous. Only in case of a failure or when replacing the gas block, venturi and/or fan, the CO<sub>2</sub> percentage should be checked.

- !** Always check all gas carrying parts for leaks (with a leak detection spray) after (maintenance) work to the boiler.

Close the relevant commissioning valves during the maintenance activities. See figure 15.a.

### Draining the boiler

The heating installation must be provided with a fill and drain valve. Use this feature also for draining the boiler.

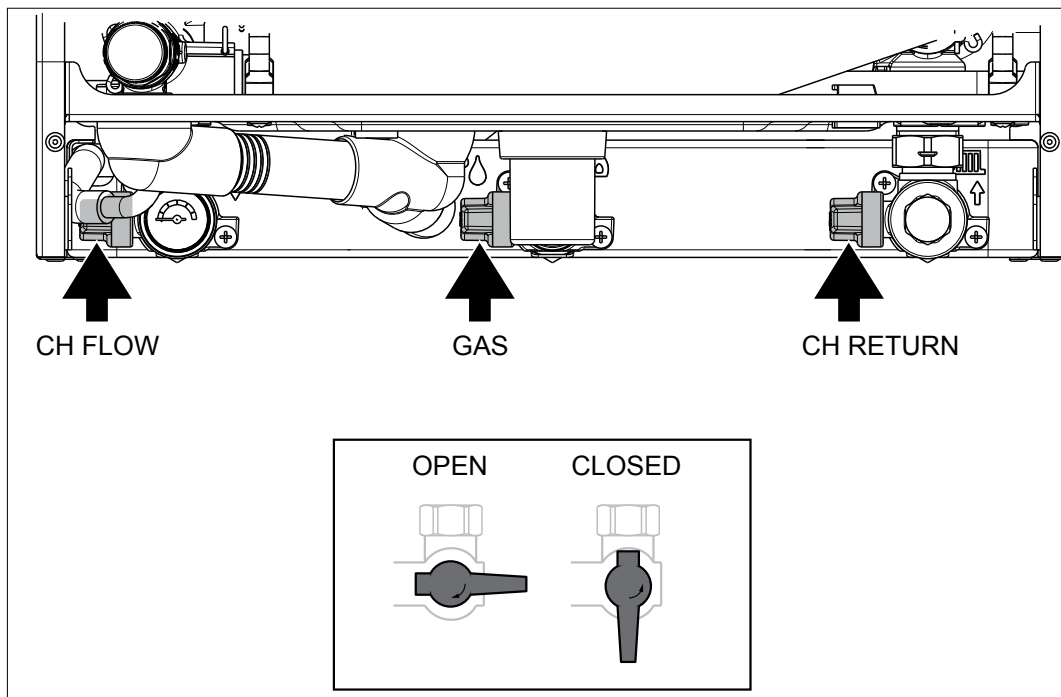

Figure 15.a

## 15.1 Checking the CO<sub>2</sub>



The CO<sub>2</sub> percentage is set in the factory. This has to be checked during inspection, maintenance and in case of a failure.

This can be verified by means of the following action:

- Set the external controls to call for heat;
- Make sure the boiler is operational and can get rid of the heat it produces;
- Calibrate the flue gas analyser;
- Place the lance of the flue gas analyser into the flue gas test point (see Figure 15.1.a);

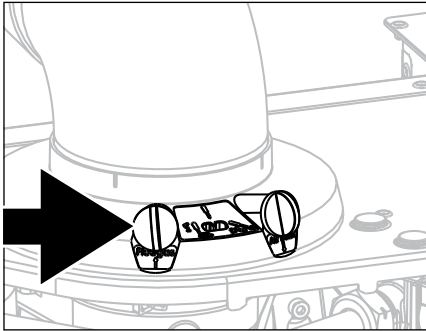

Measuring point CO<sub>2</sub> Figure 15.1.a

- Press both + buttons for 6 seconds;
- When the flame symbol appears in the display press both + buttons again for 6 seconds;
- The display shows the supply water temperature (  appears in the display);

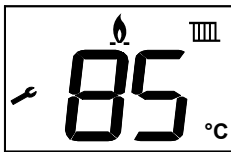

*The boiler will switch to maximum power of the heating capacity*

- Press 1x the eco- button;  
*the display shows XX% (heating capacity)*
- Leave measuring CO<sub>2</sub> to the measuring equipment.

- CO<sub>2</sub> percentage at full load = 

	<b>Natural gas</b>	<b>Propane</b>
	<b>9.0% (-0.4%, +0.6%)</b>	<b>10.3% (+/- 0.6%)</b>

- If required, you may turn the setting screw to set the correct CO<sub>2</sub> percentage.  
(refer to Figure 15.1.b).

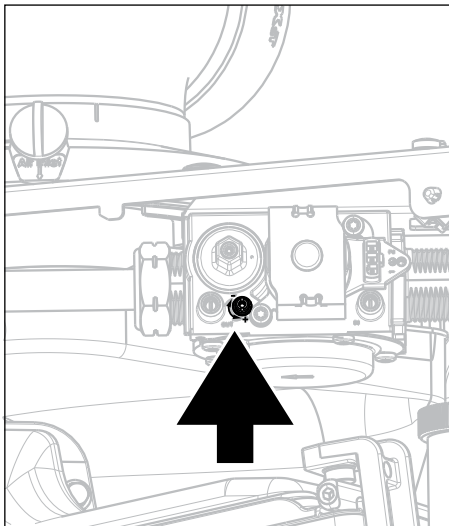

Adjustment screw CO<sub>2</sub> Figure 15.1.b

Finally, the CO<sub>2</sub> percentage at low load must be checked:

- Press on the - button until the minimum value (0%) has been reached (low load)
- Leave measuring CO<sub>2</sub> to the measuring equipment and check if the measured CO<sub>2</sub> percentage on low load is between following values:

	Natural gas	Propane
- CO <sub>2</sub> percentage at <u>low load</u> between	<b>8.7% and 9.6%</b>	<b>9.5% and 10.5%</b>

Contact ATAG when the measured values are outside this range.

End of measuring:

- Press the ESC button (  button).  
The device switches off.  
The display shows for 2 seconds code 180 or 181.  
This completes the procedure.

## 15.2 Checking flue integrity

The integrity of the flue system and performance of the boiler can be checked via the flue turret sample points shown in diagram 15.2.a.

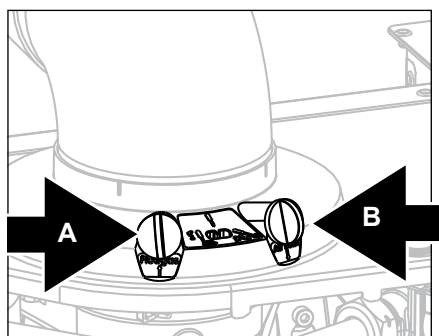

A – Flue gas sample point  
B – Air intake sample point

Figure 15.2.a

The case must be on the boiler and the boiler made to run at maximum output.

- Press both + buttons for 6 seconds;
- When the flame symbol appears in the display press both + buttons again for 6 seconds;
- The display shows the supply water temperature (  appears in the display)  
*The boiler will switch to maximum power of the heating capacity*
- Press 1x the eco- button;  
*The display shows XX% (heating capacity)*
- Insert the analyser probe into the air intake sample point.
- Ensure the probe reaches into the flow of air in air intake sample point. Ensure the sealing cone on the probe is sealed to the sample point and correctly position the end of the probe.
- Allow the readings to stabilise and check that:
  - O<sub>2</sub> is equal to, or greater than 20.6%.
  - CO<sub>2</sub> is less than 0.2%
- If the readings are outside these limits then this indicates that there is a problem with the flue system or combustion circuit, e.g. missing or dislodged seals.

End of measuring:

- Press the ESC button (  button).  
The device switches off.  
The display shows for 2 seconds code 180 or 181.  
This completes the procedure.

## 15.3 CO and combustion checks

### IMPORTANT PRELIMINARY INFORMATION ON CHECKS



**NOTE: The air gas ratio valve is factory set and must not be adjusted during commissioning unless this action is recommended following contact with the manufacturer.**

If any such adjustment is recommended and further checking of the boiler is required the installer/service engineer must be competent to carry out this work and to use the flue gas analyser accordingly.

If the boiler requires conversion to operate with a different gas family (e.g. conversion from natural gas to LPG) separate guidance will be provided by the boiler manufacturer

### PRIOR TO CO LEVEL AND COMBUSTION RATIO CHECK

The boiler manufacturer's installation instructions should have been followed, gas type verified and gas supply pressure/rate checked as required prior to commissioning.

As part of the installation process, **especially where a flue has been fitted by persons other than the boiler installer**, visually check the integrity of the whole flue system to confirm that all components are correctly assembled, fixed and supported. Check that manufacturer's max. flue lengths have not been exceeded and all guidance has been followed (e.g. Gas Safe Technical Bulletin TB008 where chimney/flues are in voids).

The flue gas analyser should be of the correct type, as specified by BS 7967

Prior to its use, the flue gas analyser should have been maintained and calibrated as specified by the manufacturer. The installer must have the relevant competence for use of the analyser.

Check and zero the analyser IN FRESH AIR as per analyser manufacturer's instructions.

Key:

**CO** = carbon monoxide    **CO<sub>2</sub>** = carbon dioxide    **O<sub>2</sub>** = oxygen    **ppm** = parts per million

**Combustion ratio** = The CO reading measured in ppm divided by the CO<sub>2</sub> reading first converted to ppm

**GU(I&U)R** = Gas safety (Installation & use) Regulation.

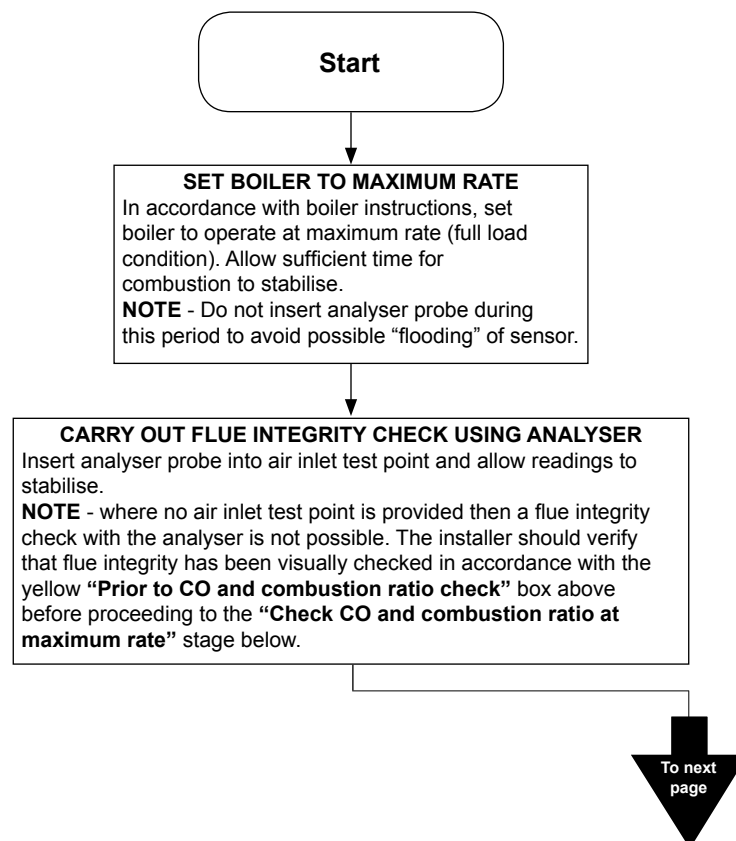

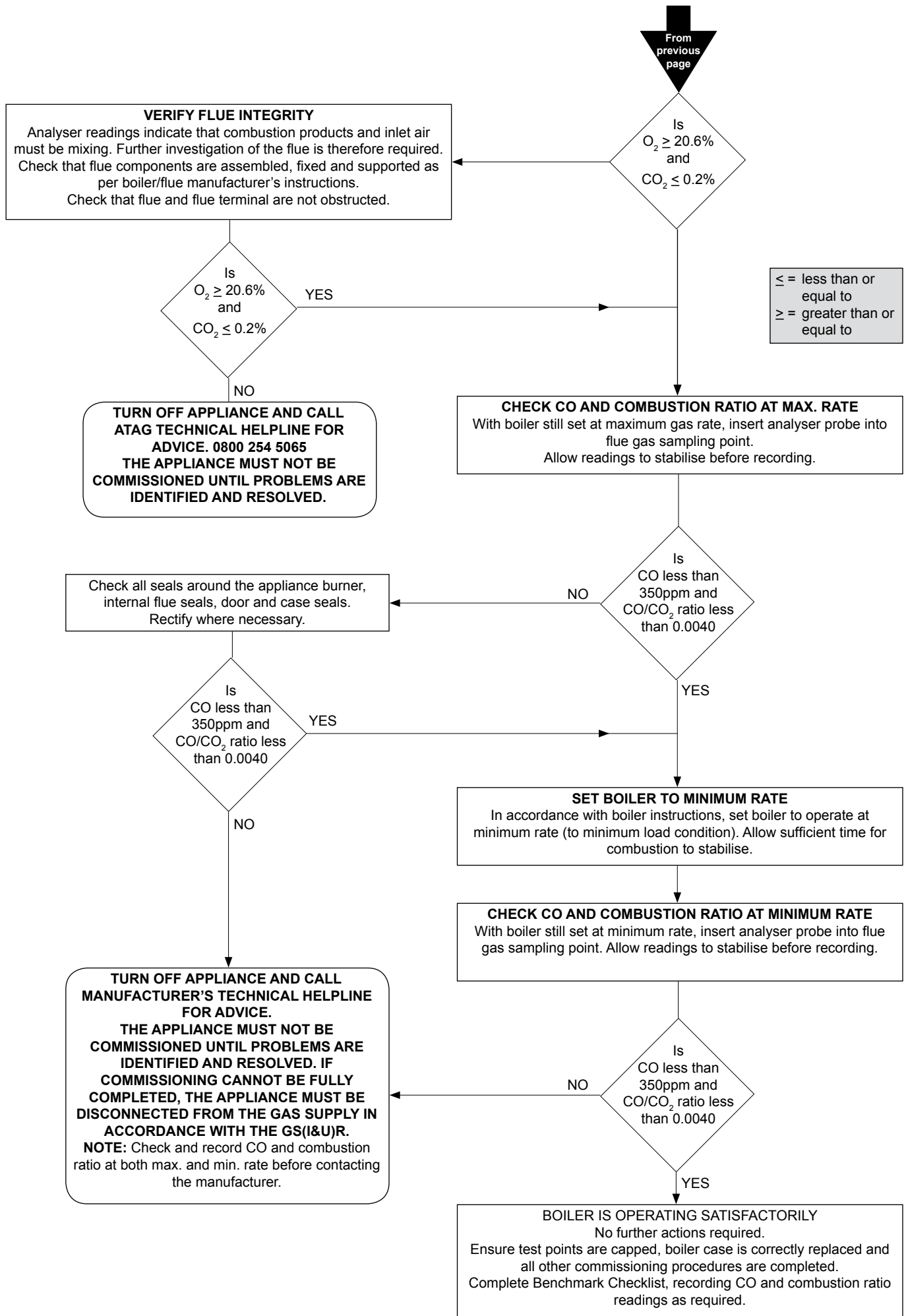

## 16 Routine servicing

Required tools:

- Cross head screwdriver
- T-handle key set with 3 bits (hex key 4mm, hex key 5mm and cross head PZ2)
- Open end wrench 8mm

In order to perform maintenance, the following actions have to be taken:

- Switch off the electrical power to the boiler;
- Remove the screws from the 2 fasteners A and B (see fig. 16.a);
- Unlock the fasteners A and B and remove the cover in a forward motion and remove the earth cable from the cover.



**Note that there is an earth cable to disconnect when removing the boiler front panel. Free space for removing the connector is about 400 mm. Remind to connect this earth cable when placing back the boiler front panel and take care the wire does not get stuck between front panel and boiler.**

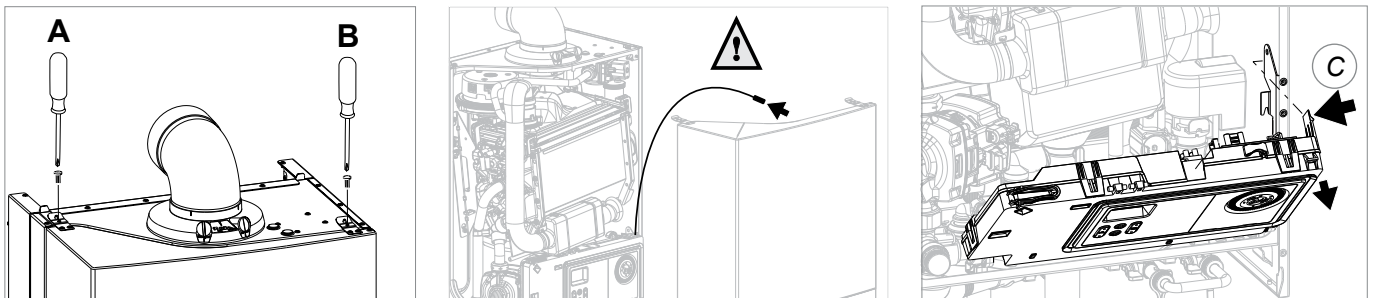

Figure 16.a

### Air box/cover

The cover also doubles as air box:

- Clean the air box/cover with a cloth and a non-abrasive cleaner;

### Siphon (see fig. 16.b)

The degree of pollution residue in the siphon is an important indication for the need of maintenance

- Turn the control unit towards by moving the handle (C) slightly to the left (see figure 16.a);
- Turn/pull the sealing ring (1) downwards;
- Turn the siphon securing clip (2) anti-clockwise;
- Pull the siphon cup (3) and siphon pipe (4) out of the heat exchanger;
- Take the siphon cup and pipe out of the boiler by moving it downwards or turn it in forward motion upwards along the heat exchanger;
- Clean the parts by rinsing them with water;
- Check the O-ring of the siphon cup and replace it if necessary;
- Grease the O-ring again with acid-free O-ring grease to simplify the reassembly.

Reassembly takes place in reverse order.

- fill the siphon with **150 ml of water**.
- If a leakage has occurred to the siphon, replace the entire siphon.

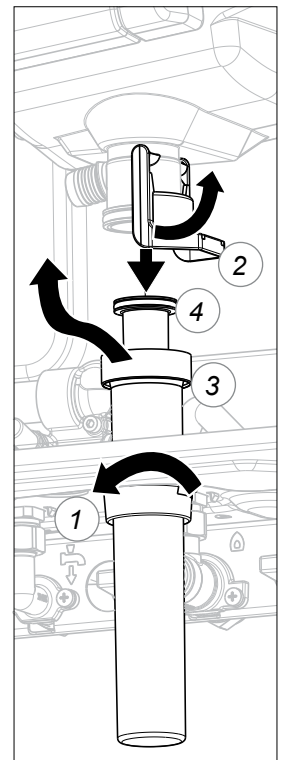

Figure 16.b

**Fan unit and burner cassette (see fig. 13.2.b-f)**

- Remove the velcro from the silencer and remove the silencer (1);
- Unscrew the coupling (2) of the gas block and the coupling on the venturi (3) and remove the gasline (4);
- **Replace the gaskets of the gasline (O-ring) with new ones;**

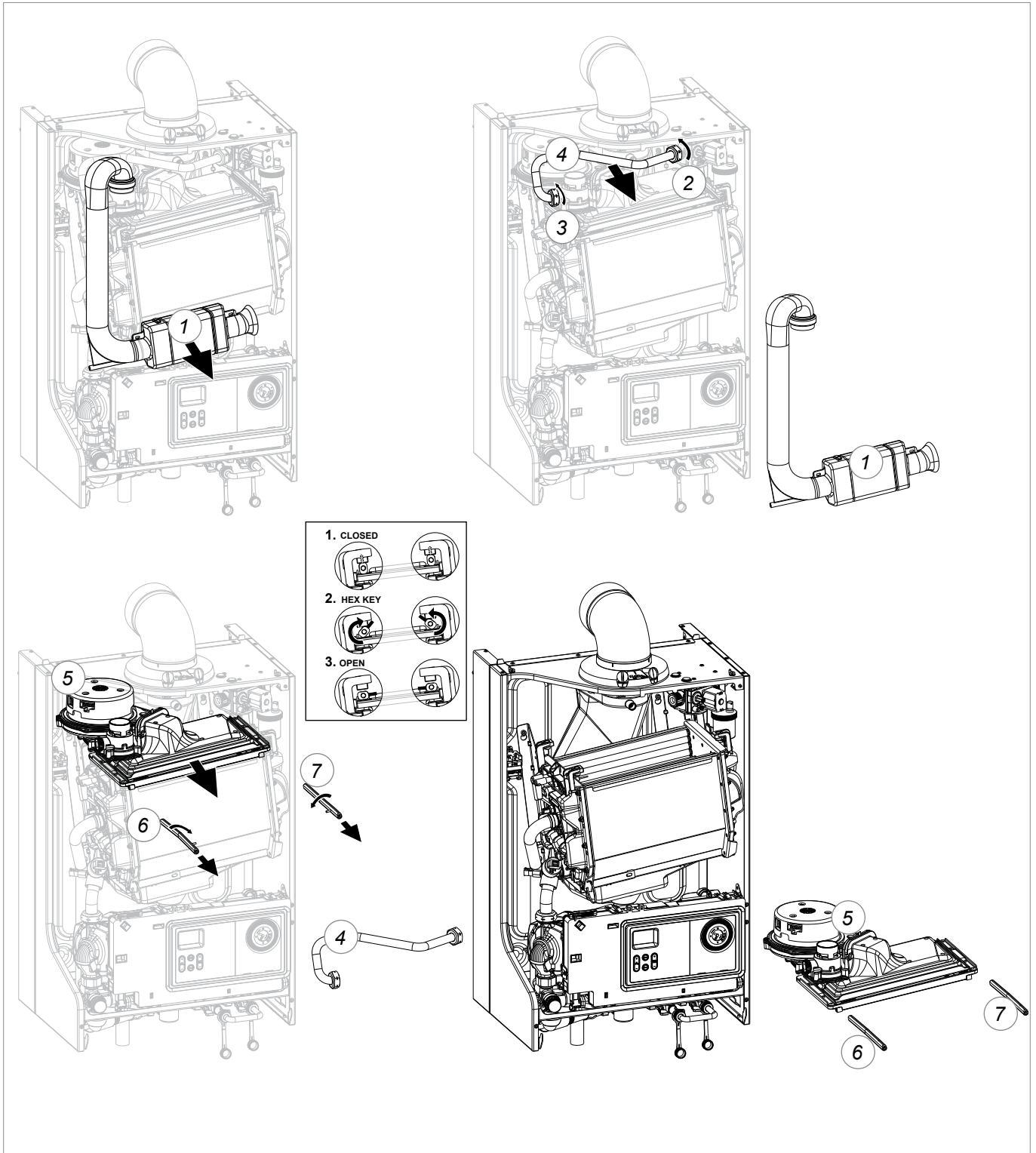

Figure 16.c

- Disconnect the electrical connections from the fan (5);
- Turn the left (6) and right (7) clamp bars a quarter turn with the hex key and pull these out in a forward motion. Mind the direction of rotation (red control cams);
- Now lift the complete fan unit (5) with the upper tray of the heat exchanger and remove it in a forward motion;
- Turn the unit up side down and remove the burner cassette (8) from the ventilator unit;
- Check the burner cassette for wear and tear, pollution and any breakages. Clean the burner cassette with a soft brush and vacuum cleaner. In the case of breakages, always replace the complete burner cassette (8);

The following operations must be performed carefully in relation to the vulnerability of the non return valve.

- After removing the burner cassette (8) the non return valve (12) becomes visible. Check that the non return valve entire circumference closes / seals completely. The valve should be able to move freely from fully open to fully closed (see fig. 16.e). Replace the non return valve if the valve does not seal properly. Follow the instructions supplied with the new part.

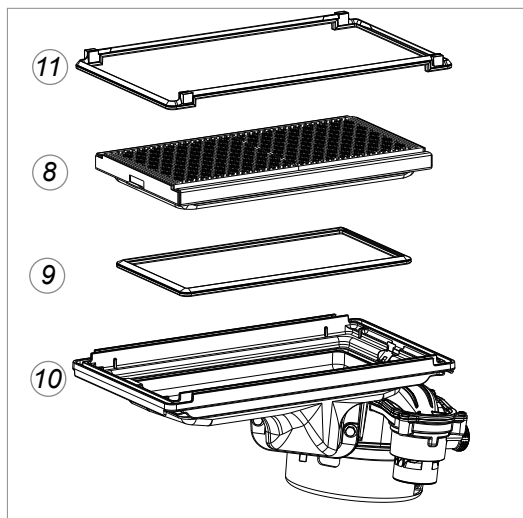

Figure 16.d

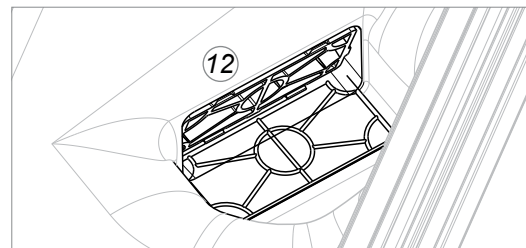

Figure 16.e

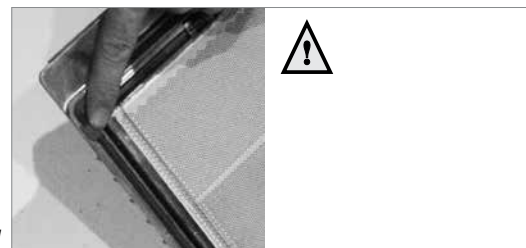

Figure 16.f

- Replace the gasket (9) between the burner (8) and upper casing (10) ;
- Replace the gasket (11) between the upper casing (10) and exchanger (Note the position in figure 16.f);
- Check the venturi (13) for pollution and clean them with a soft brush in combination with a vacuum cleaner, if necessary.

If the inside of the boiler casing is heavily polluted with dust, it is likely that the fan impeller is also polluted. To clean the fan, it has to be removed from the upper tray and the venturi. Clean the impeller with a soft brush and a vacuum cleaner. Replace the gasket and take care that the new gasket is installed properly when reassembling the fan parts.

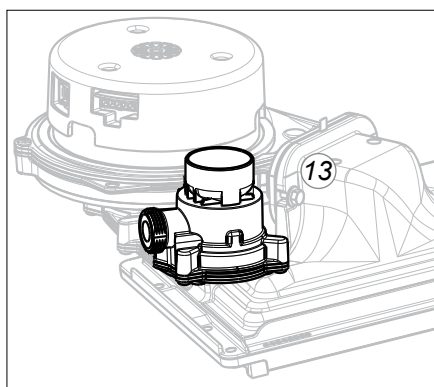

Figure 16.g

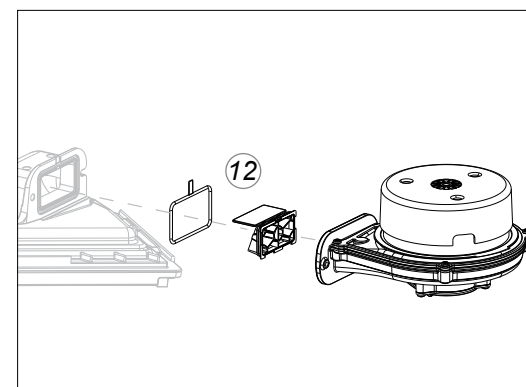

Figure 16.h

Reassembly takes place in reverse order.

### **Heat exchanger**

- Check the heat exchanger for pollution. Clean it, if necessary, with a soft brush and a vacuum cleaner. Avoid any pollution falling down.



**TOP-FLUSHING THE EXCHANGER WITH WATER IS NOT ALLOWED.**

Reassembly takes place in reverse order.



**During installation pay attention to the correct position of the clamp bars. These have to be in a vertical position.**

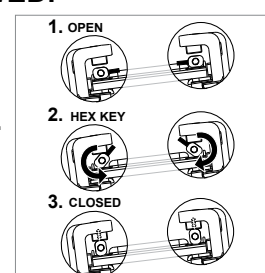

### **Ignition electrode**

Replacing the ignition electrode is necessary when the pins are worn.  
If the inspection hole is damaged, the entire ignition electrode has to be replaced.

It is replaced as follows:

- Take away the plug connections on the ignition electrode;
- Push the clip on top of the electrode upwards and take away the electrode;
- Remove and replace the gasket;

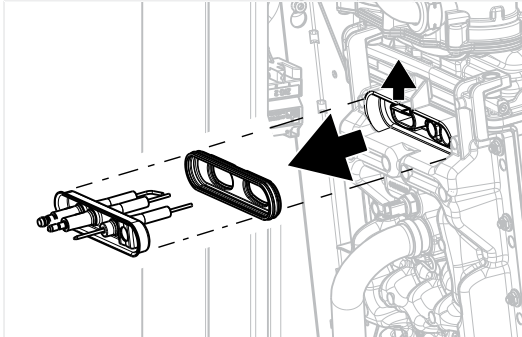

Figure 16.g

Reassembly takes place in reverse order.



**Always replace the gaskets of the removed parts during maintenance.**

Put the boiler back into operation and carry out a flue gas analysis (see page 34).



**Always put back the cover after (maintenance) work and secure it with screws A and B.  
Remind to connect this earth cable when placing back the boiler front panel and take care the wire does not get stuck between front panel and boiler.**

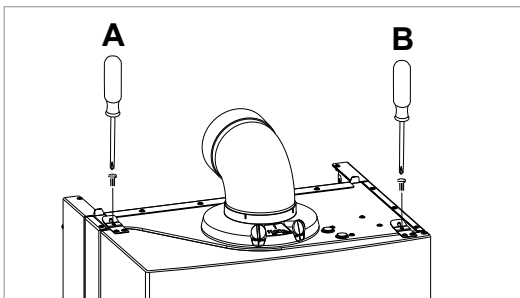

Please contact your installer or ATAG Heating Technology Ltd. for further details. Contact details can be found on the back page of this manual.



**After servicing, complete the relevant Service Interval Record section of the Benchmark Checklist located on the inside back page of the document.**

## **16.1 Component replacement**



**In the event that parts require replacement, use only genuine parts supplied by ATAG Heating Technology Ltd.**

## **16.2 User's instructions**

Advise the user that for continued efficient and safe operation, the boiler should be serviced at least once a year by qualified servicing company. It is important and strongly recommended that arrangements are made for a maintenance agreement with a qualified servicing company to ensure regular servicing of the boiler.

Please contact ATAG Heating Technology Ltd. for further details. Contact details can be found on the back page of this manual.

## **16.3 Maintenance frequency**

ATAG Heating Technology Ltd advises an annual inspection or every 1600 running hours, with a full strip down service as required, every 4 years or every 6400 running hours, whatever comes first.

## **16.4 Warranty**

For the warranty conditions we refer to the Warranty Card that is supplied with the boiler.

## 17 Error codes and fault finding

A detected failure is indicated on the display in blocking or error messages.

- **Blocking** code with spanner symbol 

Error is temporary and will cancel itself or will lock the boiler after several attempts (error)

- **Error** code with bell symbol 

Error means a lock on the boiler and can only be remedied by a reset and/or intervention by a service technician.

10	Outside sensor error (e.g. open, short circuit, out of range)
20	Flow sensor error (e.g. open, short circuit, out of range)
40	Return sensor error (e.g. open, short circuit, out of range)
50	T3 (DHW) sensor error (e.g. open, short circuit, out of range)
61	Bus communication error (contact open)
78	Water pressure outside of range or not connected
105	Venting program active when power turned on or interrupted (runs approx. 7 mins.)
110	Safety temperature exceeded
111	Maximum temperature exceeded
117	Pressure too high (> 3 bar) or pump pressure increase too high
118	Pressure too low (< 1 bar) or pump pressure increase too low (no pump detection)
119	Link on X2 position 4 and 5 missing
129	Fan error (fan does not start up)
133	No flame after 5 ignition attempts
151	Fan error (speed control is not achieved or is out of range) or control unit defective
154	Flow increases too fast $\Delta T$ too large, return > flow
180	No error: shortly visible when leaving chimney sweep function
181	No error: shortly visible when leaving commissioning mode

Example of display of error message

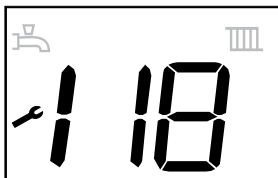

## Annex A System water additives

When the filling water requirements as referred to in chapter Water Quality have been met, certain additives are allowed for the below mentioned applications and related dosage. Warranty on ATAG delivered installation products expires, if these additives and concentrations are not used in accordance with this annex.

Additive type	Supplier and specifications	Max. concentration	Application
Corrosion inhibitors	ATAG Central Heating Protector. Build Cert Approved	500 ml / 100 litres	Suitable for mixed metal and plastic systems. Prevents corrosion and limescale.
	Sentinel X100 Corrosion resistant protection agent of CH systems Kiwa certified	1-2 l/100 litres CH water content	Aqueous solution of organic and inorganic agents preventing corrosion and scale forming
	Fernox F1 Protector Corrosion resistant protection agent of CH systems Kiwa certified KIWA-ATA K62581, Belgaqua certified Cat III	500 ml can or 265 ml Express / 100 litres CH water content	Preventing corrosion and scale forming
Anti-freeze	Kalsbeek Monopropyleneglycol / propane-1,2-diol + inhibitors AKWA-Colpro KIWA-ATA Nr. 2104/1	50% w/w	Anti-freeze
	Tyfocon L Monopropyleneglycol / propane-1,2-diol + inhibitors	50% w/w	Anti-freeze
	Sentinel X500 Monopropyleneglycol + inhibitors Kiwa certified	20-50% w/w	Anti-freeze
	Fernox Alphi 11 Monopropyleneglycol + inhibitors Kiwa certified KIWA-ATA K62581, Belgaqua certified Cat III	25-50% w/w	Anti-freeze in combination with F1 Protector
System cleaners	ATAG Central Heating Universal Cleaner	500 ml / 100 litres	Suitable for mixed metal and plastic systems. Disperses sludge, limescale and other deposits.
	Sentinel X300 Solution of phosphate, organic heterocyclic compounds, polymers and organic bases Kiwa certified	1 litre / 100 litres	For new CH installations Removes oils/grease and flow control agents
	Sentinel X400 Solution of synthetic organic polymers	1-2 litres / 100 litres	For cleaning existing CH-installations Removes sediments.
	Sentinel X800 Jetflo Aqueous emulsion of dispersants, moistening agents and inhibitors	1-2 litres / 100 litres	For cleaning new and existing CH-installations Removes iron and lime-related sediments.
	Fernox F3 Cleaner Liquid pH neutral universal cleaner for pre-commissioning new systems	500 ml / 100 litres	For cleaning new and existing CH-installations Removes sludge, limescale and other debris.
	Fernox F5 Cleaner, Express pH neutral universal cleaner concentrate for pre-commissioning new systems	295 / 100 litres	For cleaning new and existing CH-installations Removes sludge, limescale and other debris.

ATAG support the use of inhibitors suitable for mixed metal applications that keep the pH level between 6 and 8. Dosage levels as per manufacturers instructions. Preferred inhibitor suppliers are ATAG Heating Technology, Fernox and Sentinel.

## Annex B Declaration of conformity

### CE DECLARATION OF CONFORMITY

Hereby declares ATAG Verwarming Nederland BV that,

the condensing boiler types: ATAG

iS12            iS15            iS18            iS24            iS32            iS40

are in conformity with the provisions of the following EC Directives, including all amendments, and with national legislation implementing these directives:

<u>Directive</u>		<u>Used standards</u>
Gas Appliance Directive	2009/142/EC	EN15502-1:2012 EN15502-2:2012 EN60335-1:2011 EN60335-2-102:2010
Boiler Efficiency Directive	92/42/EEC	EN677: 1998 EN132031/2:2014
Low Voltage Directive	2006/95/EG	EN60335-2-102 :2010 EN60335-1: 2011
EMC Directive	2004/108//EG	EN60335-2-102 :2010 EN61000-3-2: 2009 EN61000-3-3: 2008 EN55014-1:2011 EN55014-2:2008
Ecodesign Directive	2009/125/EC	EN 15036-1:2006 EN 13203-2: 2014 EN 15502-1: 2012
Labelling Directive	2010/30/EU	
Report numbers	GAD            BED            LVD            EMC D	
	141000634    141000634    141000634    141000634	

and that the products are in conformity with EC type-examination certificate number E0430, as stated by KIWA-Gastec Certification BV, Apeldoorn, The Netherlands.

Date : 1 December 2015

Signature :

Full name : Drs. C. Berlo  
CEO

**ATAG**  
**Verwarming**

Adres: Galileïstraat 27, 7131 PE Lichtenvoorde • Postadres: Postbus 105, 7130 AC Lichtenvoorde  
Telefoon: +31(0) 544 391777, Fax: +31(0) 544 391703  
E-mail: info@atagverwarming.com Internet: http://www.atagverwarming.nl

## Annex C Short parts list

### iS Range

Description	Qty	ATAG Pt. No.
Heat exchanger iCon1	1	S4863100
Heat exchanger iCon2	1	S4863200
Pump Grundfos UPM3 15-75	1	S4856100
Boiler control LMU iS	1	S4864400
Fan iCon 1	1	S4858300
Fan iCon 2	1	S4858400
Expansion tank 8L	1	S4854300
Gas valve	1	S4856300
Burner complete iCon1	1	S4849100
Burner complete iCon2	1	S4849200
Condensate tray iCon1	1	S4863400
Condensate tray iCon2	1	S4863500
Igniter & gasket	1	S4863600
Water pressure sensor	1	S4466300
Igniter transformer	1	S4851000
Cable harness combi & system	1	S4863900
Air vent	1	S4419110
Siphon complete set	1	S4863700
Igniter cables	1	S4863800
NTC flow	1	S4745900
Flex hose expansion vessel	1	S4856900
Maintenance Set iCon1	1	S4867900
Maintenance Set iCon2	1	S4868000
Silencer iCon 1 & 2	1	S4847800
Gasket condensate tray iCon1	1	S4854600
Gasket condensate tray iCon2	1	S4854700
NTC return	1	S4746000
Connector roomstat (Black)	1	S4745100
Fuse T3,15 250V 3pcs	1	S4749200
Gasket pump 2pcs	1	S0009000
Clamp bar long	1	S4850900
Safety relieve valve	1	S4852500
Pressure gauge analogue	1	S4868100
Connector OpenTherm (Blue)	1	S4745000
Connector External Safety	1	S4745200
Connector Outside Sensor (Salmon Pink)	1	S4745400
Drain Off	1	44867400
Flue Gas Non Return Valve	1	AA07400U

# Benchmark Commissioning and Servicing Section

It is a requirement that the boiler is installed and commissioned to the manufacturers instructions and the data fields on the commissioning checklist completed in full.

To instigate the boiler guarantee the boiler needs to be registered with the manufacturer within one month of the installation.

To maintain the boiler guarantee it is essential that the boiler is serviced annually by a Gas Safe registered engineer who has been trained on the boiler installed. The service details should be recorded on the Benchmark Service Interval Record and left with the householder.



[www.centralheating.co.uk](http://www.centralheating.co.uk)

# GAS BOILER SYSTEM COMMISSIONING CHECKLIST

This Commissioning Checklist is to be completed in full by the competent person who commissioned the boiler as a means of demonstrating compliance with the appropriate Building Regulations and then handed to the customer to keep for future reference.

Failure to install and commission according to the manufacturer's instructions and complete this Benchmark Commissioning Checklist will invalidate the warranty. This does not affect the customer's statutory rights.

Customer name:	Telephone number:
Address:	
Boiler make and model:	
Boiler serial number:	
Commissioned by (PRINT NAME):	Gas Safe register number:
Company name:	Telephone number:
Company address:	
	Commissioning date:

**To be completed by the customer on receipt of a Building Regulations Compliance Certificate\***

Building Regulations Notification Number (if applicable):

CONTROLS (tick the appropriate boxes)			
Time and temperature control to heating	Room thermostat and programmer/timer		Programmable room thermostat
	Load/weather compensation		Optimum start control
Time and temperature control to hot water	Cylinder thermostat and programmer/timer		Combination Boiler
Heating zone valves	Fitted		Not required
Hot water zone valves	Fitted		Not required
Thermostatic radiator valves	Fitted		Not required
Automatic bypass to system	Fitted		Not required
Boiler interlock			Provided

**ALL SYSTEMS**

The system has been flushed and cleaned in accordance with BS7593 and boiler manufacturer's instructions Yes

What system cleaner was used?

What inhibitor was used? Quantity litres

Has a primary water system filter been installed? Yes  No

**CENTRAL HEATING MODE** measure and record:

Gas rate	m <sup>3</sup> /hr	<b>OR</b>	ft <sup>3</sup> /hr
Burner operating pressure (if applicable)	mbar	<b>OR</b> Gas inlet pressure	mbar
Central heating flow temperature			°C
Central heating return temperature			°C

**COMBINATION BOILERS ONLY**

Is the installation in a hard water area (above 200ppm)? Yes  No

If yes, and if required by the manufacturer, has a water scale reducer been fitted? Yes  No

What type of scale reducer has been fitted?

**DOMESTIC HOT WATER MODE** Measure and Record:

Gas rate	m <sup>3</sup> /hr	<b>OR</b>	ft <sup>3</sup> /hr
Burner operating pressure (at maximum rate)	mbar	<b>OR</b> Gas inlet pressure at maximum rate	mbar
Cold water inlet temperature			°C
Hot water has been checked at all outlets	Yes <input type="checkbox"/>	Temperature	°C
Water flow rate			l/min

**CONDENSING BOILERS ONLY**

The condensate drain has been installed in accordance with the manufacturer's instructions and/or BS5546/BS6798 Yes

**ALL INSTALLATIONS**

Record the following:	At max. rate:	CO	ppm	<b>AND</b>	CO/CO <sub>2</sub>	Ratio
	At min. rate: (where possible)	CO	ppm	<b>AND</b>	CO/CO <sub>2</sub>	Ratio
The heating and hot water system complies with the appropriate Building Regulations <span style="float: right;">Yes <input type="checkbox"/></span>						
The boiler and associated products have been installed and commissioned in accordance with the manufacturer's instructions <span style="float: right;">Yes <input type="checkbox"/></span>						
The operation of the boiler and system controls have been demonstrated to and understood by the customer <span style="float: right;">Yes <input type="checkbox"/></span>						
The manufacturer's literature, including Benchmark Checklist and Service Record, has been explained and left with the customer <span style="float: right;">Yes <input type="checkbox"/></span>						

Commissioning Engineer's Signature

Customer's Signature

(To confirm satisfactory demonstration and receipt of manufacturer's literature)

\*All installations in England and Wales must be notified to Local Authority Building Control (LABC) either directly or through a Competent Persons Scheme. A Building Regulations Compliance Certificate will then be issued to the customer.



# SERVICE RECORD

It is recommended that your heating system is serviced regularly and that the appropriate Service Interval Record is completed.

## Service Provider

Before completing the appropriate Service Record below, please ensure you have carried out the service as described in the manufacturer's instructions. Always use the manufacturer's specified spare part when replacing controls.

<table border="1" style="width: 100%; border-collapse: collapse;"> <tr> <td colspan="2"><b>SERVICE 01</b></td> <td colspan="2">Date:</td> </tr> <tr><td colspan="4">Engineer name:</td></tr> <tr><td colspan="4">Company name:</td></tr> <tr><td colspan="4">Telephone No:</td></tr> <tr><td colspan="4">Gas safe register No:</td></tr> <tr> <td rowspan="2">Record:</td> <td>At max. rate:</td> <td>CO ppm</td> <td><b>AND</b> CO<sub>2</sub> %</td> </tr> <tr> <td>At min. rate: (Where Possible)</td> <td>CO ppm</td> <td><b>AND</b> CO<sub>2</sub> %</td> </tr> <tr><td colspan="4">Comments:</td></tr> <tr><td colspan="4">Signature</td></tr> </table>	<b>SERVICE 01</b>		Date:		Engineer name:				Company name:				Telephone No:				Gas safe register No:				Record:	At max. rate:	CO ppm	<b>AND</b> CO <sub>2</sub> %	At min. rate: (Where Possible)	CO ppm	<b>AND</b> CO <sub>2</sub> %	Comments:				Signature				<table border="1" style="width: 100%; border-collapse: collapse;"> <tr> <td colspan="2"><b>SERVICE 02</b></td> <td colspan="2">Date:</td> </tr> <tr><td colspan="4">Engineer name:</td></tr> <tr><td colspan="4">Company name:</td></tr> <tr><td colspan="4">Telephone No:</td></tr> <tr><td colspan="4">Gas safe register No:</td></tr> <tr> <td rowspan="2">Record:</td> <td>At max. rate:</td> <td>CO ppm</td> <td><b>AND</b> CO<sub>2</sub> %</td> </tr> <tr> <td>At min. rate: (Where Possible)</td> <td>CO ppm</td> <td><b>AND</b> CO<sub>2</sub> %</td> </tr> <tr><td colspan="4">Comments:</td></tr> <tr><td colspan="4">Signature</td></tr> </table>	<b>SERVICE 02</b>		Date:		Engineer name:				Company name:				Telephone No:				Gas safe register No:				Record:	At max. rate:	CO ppm	<b>AND</b> CO <sub>2</sub> %	At min. rate: (Where Possible)	CO ppm	<b>AND</b> CO <sub>2</sub> %	Comments:				Signature			
<b>SERVICE 01</b>		Date:																																																																					
Engineer name:																																																																							
Company name:																																																																							
Telephone No:																																																																							
Gas safe register No:																																																																							
Record:	At max. rate:	CO ppm	<b>AND</b> CO <sub>2</sub> %																																																																				
	At min. rate: (Where Possible)	CO ppm	<b>AND</b> CO <sub>2</sub> %																																																																				
Comments:																																																																							
Signature																																																																							
<b>SERVICE 02</b>		Date:																																																																					
Engineer name:																																																																							
Company name:																																																																							
Telephone No:																																																																							
Gas safe register No:																																																																							
Record:	At max. rate:	CO ppm	<b>AND</b> CO <sub>2</sub> %																																																																				
	At min. rate: (Where Possible)	CO ppm	<b>AND</b> CO <sub>2</sub> %																																																																				
Comments:																																																																							
Signature																																																																							
<table border="1" style="width: 100%; border-collapse: collapse;"> <tr> <td colspan="2"><b>SERVICE 03</b></td> <td colspan="2">Date:</td> </tr> <tr><td colspan="4">Engineer name:</td></tr> <tr><td colspan="4">Company name:</td></tr> <tr><td colspan="4">Telephone No:</td></tr> <tr><td colspan="4">Gas safe register No:</td></tr> <tr> <td rowspan="2">Record:</td> <td>At max. rate:</td> <td>CO ppm</td> <td><b>AND</b> CO<sub>2</sub> %</td> </tr> <tr> <td>At min. rate: (Where Possible)</td> <td>CO ppm</td> <td><b>AND</b> CO<sub>2</sub> %</td> </tr> <tr><td colspan="4">Comments:</td></tr> <tr><td colspan="4">Signature</td></tr> </table>	<b>SERVICE 03</b>		Date:		Engineer name:				Company name:				Telephone No:				Gas safe register No:				Record:	At max. rate:	CO ppm	<b>AND</b> CO <sub>2</sub> %	At min. rate: (Where Possible)	CO ppm	<b>AND</b> CO <sub>2</sub> %	Comments:				Signature				<table border="1" style="width: 100%; border-collapse: collapse;"> <tr> <td colspan="2"><b>SERVICE 04</b></td> <td colspan="2">Date:</td> </tr> <tr><td colspan="4">Engineer name:</td></tr> <tr><td colspan="4">Company name:</td></tr> <tr><td colspan="4">Telephone No:</td></tr> <tr><td colspan="4">Gas safe register No:</td></tr> <tr> <td rowspan="2">Record:</td> <td>At max. rate:</td> <td>CO ppm</td> <td><b>AND</b> CO<sub>2</sub> %</td> </tr> <tr> <td>At min. rate: (Where Possible)</td> <td>CO ppm</td> <td><b>AND</b> CO<sub>2</sub> %</td> </tr> <tr><td colspan="4">Comments:</td></tr> <tr><td colspan="4">Signature</td></tr> </table>	<b>SERVICE 04</b>		Date:		Engineer name:				Company name:				Telephone No:				Gas safe register No:				Record:	At max. rate:	CO ppm	<b>AND</b> CO <sub>2</sub> %	At min. rate: (Where Possible)	CO ppm	<b>AND</b> CO <sub>2</sub> %	Comments:				Signature			
<b>SERVICE 03</b>		Date:																																																																					
Engineer name:																																																																							
Company name:																																																																							
Telephone No:																																																																							
Gas safe register No:																																																																							
Record:	At max. rate:	CO ppm	<b>AND</b> CO <sub>2</sub> %																																																																				
	At min. rate: (Where Possible)	CO ppm	<b>AND</b> CO <sub>2</sub> %																																																																				
Comments:																																																																							
Signature																																																																							
<b>SERVICE 04</b>		Date:																																																																					
Engineer name:																																																																							
Company name:																																																																							
Telephone No:																																																																							
Gas safe register No:																																																																							
Record:	At max. rate:	CO ppm	<b>AND</b> CO <sub>2</sub> %																																																																				
	At min. rate: (Where Possible)	CO ppm	<b>AND</b> CO <sub>2</sub> %																																																																				
Comments:																																																																							
Signature																																																																							
<table border="1" style="width: 100%; border-collapse: collapse;"> <tr> <td colspan="2"><b>SERVICE 05</b></td> <td colspan="2">Date:</td> </tr> <tr><td colspan="4">Engineer name:</td></tr> <tr><td colspan="4">Company name:</td></tr> <tr><td colspan="4">Telephone No:</td></tr> <tr><td colspan="4">Gas safe register No:</td></tr> <tr> <td rowspan="2">Record:</td> <td>At max. rate:</td> <td>CO ppm</td> <td><b>AND</b> CO<sub>2</sub> %</td> </tr> <tr> <td>At min. rate: (Where Possible)</td> <td>CO ppm</td> <td><b>AND</b> CO<sub>2</sub> %</td> </tr> <tr><td colspan="4">Comments:</td></tr> <tr><td colspan="4">Signature</td></tr> </table>	<b>SERVICE 05</b>		Date:		Engineer name:				Company name:				Telephone No:				Gas safe register No:				Record:	At max. rate:	CO ppm	<b>AND</b> CO <sub>2</sub> %	At min. rate: (Where Possible)	CO ppm	<b>AND</b> CO <sub>2</sub> %	Comments:				Signature				<table border="1" style="width: 100%; border-collapse: collapse;"> <tr> <td colspan="2"><b>SERVICE 06</b></td> <td colspan="2">Date:</td> </tr> <tr><td colspan="4">Engineer name:</td></tr> <tr><td colspan="4">Company name:</td></tr> <tr><td colspan="4">Telephone No:</td></tr> <tr><td colspan="4">Gas safe register No:</td></tr> <tr> <td rowspan="2">Record:</td> <td>At max. rate:</td> <td>CO ppm</td> <td><b>AND</b> CO<sub>2</sub> %</td> </tr> <tr> <td>At min. rate: (Where Possible)</td> <td>CO ppm</td> <td><b>AND</b> CO<sub>2</sub> %</td> </tr> <tr><td colspan="4">Comments:</td></tr> <tr><td colspan="4">Signature</td></tr> </table>	<b>SERVICE 06</b>		Date:		Engineer name:				Company name:				Telephone No:				Gas safe register No:				Record:	At max. rate:	CO ppm	<b>AND</b> CO <sub>2</sub> %	At min. rate: (Where Possible)	CO ppm	<b>AND</b> CO <sub>2</sub> %	Comments:				Signature			
<b>SERVICE 05</b>		Date:																																																																					
Engineer name:																																																																							
Company name:																																																																							
Telephone No:																																																																							
Gas safe register No:																																																																							
Record:	At max. rate:	CO ppm	<b>AND</b> CO <sub>2</sub> %																																																																				
	At min. rate: (Where Possible)	CO ppm	<b>AND</b> CO <sub>2</sub> %																																																																				
Comments:																																																																							
Signature																																																																							
<b>SERVICE 06</b>		Date:																																																																					
Engineer name:																																																																							
Company name:																																																																							
Telephone No:																																																																							
Gas safe register No:																																																																							
Record:	At max. rate:	CO ppm	<b>AND</b> CO <sub>2</sub> %																																																																				
	At min. rate: (Where Possible)	CO ppm	<b>AND</b> CO <sub>2</sub> %																																																																				
Comments:																																																																							
Signature																																																																							
<table border="1" style="width: 100%; border-collapse: collapse;"> <tr> <td colspan="2"><b>SERVICE 07</b></td> <td colspan="2">Date:</td> </tr> <tr><td colspan="4">Engineer name:</td></tr> <tr><td colspan="4">Company name:</td></tr> <tr><td colspan="4">Telephone No:</td></tr> <tr><td colspan="4">Gas safe register No:</td></tr> <tr> <td rowspan="2">Record:</td> <td>At max. rate:</td> <td>CO ppm</td> <td><b>AND</b> CO<sub>2</sub> %</td> </tr> <tr> <td>At min. rate: (Where Possible)</td> <td>CO ppm</td> <td><b>AND</b> CO<sub>2</sub> %</td> </tr> <tr><td colspan="4">Comments:</td></tr> <tr><td colspan="4">Signature</td></tr> </table>	<b>SERVICE 07</b>		Date:		Engineer name:				Company name:				Telephone No:				Gas safe register No:				Record:	At max. rate:	CO ppm	<b>AND</b> CO <sub>2</sub> %	At min. rate: (Where Possible)	CO ppm	<b>AND</b> CO <sub>2</sub> %	Comments:				Signature				<table border="1" style="width: 100%; border-collapse: collapse;"> <tr> <td colspan="2"><b>SERVICE 08</b></td> <td colspan="2">Date:</td> </tr> <tr><td colspan="4">Engineer name:</td></tr> <tr><td colspan="4">Company name:</td></tr> <tr><td colspan="4">Telephone No:</td></tr> <tr><td colspan="4">Gas safe register No:</td></tr> <tr> <td rowspan="2">Record:</td> <td>At max. rate:</td> <td>CO ppm</td> <td><b>AND</b> CO<sub>2</sub> %</td> </tr> <tr> <td>At min. rate: (Where Possible)</td> <td>CO ppm</td> <td><b>AND</b> CO<sub>2</sub> %</td> </tr> <tr><td colspan="4">Comments:</td></tr> <tr><td colspan="4">Signature</td></tr> </table>	<b>SERVICE 08</b>		Date:		Engineer name:				Company name:				Telephone No:				Gas safe register No:				Record:	At max. rate:	CO ppm	<b>AND</b> CO <sub>2</sub> %	At min. rate: (Where Possible)	CO ppm	<b>AND</b> CO <sub>2</sub> %	Comments:				Signature			
<b>SERVICE 07</b>		Date:																																																																					
Engineer name:																																																																							
Company name:																																																																							
Telephone No:																																																																							
Gas safe register No:																																																																							
Record:	At max. rate:	CO ppm	<b>AND</b> CO <sub>2</sub> %																																																																				
	At min. rate: (Where Possible)	CO ppm	<b>AND</b> CO <sub>2</sub> %																																																																				
Comments:																																																																							
Signature																																																																							
<b>SERVICE 08</b>		Date:																																																																					
Engineer name:																																																																							
Company name:																																																																							
Telephone No:																																																																							
Gas safe register No:																																																																							
Record:	At max. rate:	CO ppm	<b>AND</b> CO <sub>2</sub> %																																																																				
	At min. rate: (Where Possible)	CO ppm	<b>AND</b> CO <sub>2</sub> %																																																																				
Comments:																																																																							
Signature																																																																							
<table border="1" style="width: 100%; border-collapse: collapse;"> <tr> <td colspan="2"><b>SERVICE 09</b></td> <td colspan="2">Date:</td> </tr> <tr><td colspan="4">Engineer name:</td></tr> <tr><td colspan="4">Company name:</td></tr> <tr><td colspan="4">Telephone No:</td></tr> <tr><td colspan="4">Gas safe register No:</td></tr> <tr> <td rowspan="2">Record:</td> <td>At max. rate:</td> <td>CO ppm</td> <td><b>AND</b> CO<sub>2</sub> %</td> </tr> <tr> <td>At min. rate: (Where Possible)</td> <td>CO ppm</td> <td><b>AND</b> CO<sub>2</sub> %</td> </tr> <tr><td colspan="4">Comments:</td></tr> <tr><td colspan="4">Signature</td></tr> </table>	<b>SERVICE 09</b>		Date:		Engineer name:				Company name:				Telephone No:				Gas safe register No:				Record:	At max. rate:	CO ppm	<b>AND</b> CO <sub>2</sub> %	At min. rate: (Where Possible)	CO ppm	<b>AND</b> CO <sub>2</sub> %	Comments:				Signature				<table border="1" style="width: 100%; border-collapse: collapse;"> <tr> <td colspan="2"><b>SERVICE 10</b></td> <td colspan="2">Date:</td> </tr> <tr><td colspan="4">Engineer name:</td></tr> <tr><td colspan="4">Company name:</td></tr> <tr><td colspan="4">Telephone No:</td></tr> <tr><td colspan="4">Gas safe register No:</td></tr> <tr> <td rowspan="2">Record:</td> <td>At max. rate:</td> <td>CO ppm</td> <td><b>AND</b> CO<sub>2</sub> %</td> </tr> <tr> <td>At min. rate: (Where Possible)</td> <td>CO ppm</td> <td><b>AND</b> CO<sub>2</sub> %</td> </tr> <tr><td colspan="4">Comments:</td></tr> <tr><td colspan="4">Signature</td></tr> </table>	<b>SERVICE 10</b>		Date:		Engineer name:				Company name:				Telephone No:				Gas safe register No:				Record:	At max. rate:	CO ppm	<b>AND</b> CO <sub>2</sub> %	At min. rate: (Where Possible)	CO ppm	<b>AND</b> CO <sub>2</sub> %	Comments:				Signature			
<b>SERVICE 09</b>		Date:																																																																					
Engineer name:																																																																							
Company name:																																																																							
Telephone No:																																																																							
Gas safe register No:																																																																							
Record:	At max. rate:	CO ppm	<b>AND</b> CO <sub>2</sub> %																																																																				
	At min. rate: (Where Possible)	CO ppm	<b>AND</b> CO <sub>2</sub> %																																																																				
Comments:																																																																							
Signature																																																																							
<b>SERVICE 10</b>		Date:																																																																					
Engineer name:																																																																							
Company name:																																																																							
Telephone No:																																																																							
Gas safe register No:																																																																							
Record:	At max. rate:	CO ppm	<b>AND</b> CO <sub>2</sub> %																																																																				
	At min. rate: (Where Possible)	CO ppm	<b>AND</b> CO <sub>2</sub> %																																																																				
Comments:																																																																							
Signature																																																																							

\*All installations in England and Wales must be notified to Local Authority Building Control (LABC) either directly or through a Competent Persons Scheme. A Building Regulations Compliance Certificate will then be issued to the customer.



# ATAG



ATAG Heating Technology Ltd. • 47 Castle Street • Reading • Berkshire RG1 7SR  
Phone: 0800 254 5061 • E-mail: [info@atag-heating.co.uk](mailto:info@atag-heating.co.uk) • Internet: [www.atagheating.co.uk](http://www.atagheating.co.uk)

This renewed publication cancels all previous installation instructions. The company reserves the right to change the specifications and dimensions without prior notice.