

INSTALLATION, COMMISSIONING AND SERVICING INSTRUCTIONS

WALL HUNG RSF GAS FIRED CONDENSING REGULAR BOILER

GREENSTAR CDi CLASSIC REGULAR ^{ErP}

FOR OPEN VENTED AND SEALED CENTRAL HEATING SYSTEMS AND INDIRECT DOMESTIC HOT WATER



THE APPLIANCE IS FOR USE WITH NATURAL GAS OR L.P.G.
(Cat II 2H3P TYPE C13 & C33)

NATURAL GAS:

30CDi Classic Regular ^{ErP} GC Number 41-406-33

40CDi Classic Regular ^{ErP} GC Number 41-406-35

LIQUID PETROLEUM GAS:

30CDi Classic Regular ^{ErP} GC Number 41-406-34

40CDi Classic Regular ^{ErP} GC Number 41-406-36



CONTENTS

| | | | | | |
|----------|----------------------------------------------------|-----------|----------|----------------------------------------------|-----------|
| 1 | KEY TO SYMBOLS AND SAFETY PRECAUTIONS | 3 | 6 | SERVICING AND SPARES | 34 |
| 1.1 | Key to symbols | 3 | 6.1 | Inspection and spares | 34 |
| 1.2 | Safety precautions | 3 | 6.1.1 | Inspection | 34 |
| | | | 6.1.2 | Checking flue integrity | 34 |
| | | | 6.1.3 | Component Access | 35 |
| 2 | APPLIANCE INFORMATION | 5 | 6.1.4 | Fan pressure test | 35 |
| 2.1 | General information | 5 | 6.1.5 | To Clean the Heat Exchanger | 36 |
| 2.2 | Technical data | 6 | 6.1.6 | To Clean the Burner | 36 |
| 2.3 | Product data on energy consumption | 7 | 6.1.7 | To Check the Diaphragm in Burner Cover | 37 |
| 2.4 | Layout & components | 8 | 6.1.8 | Re-assembly of the burner cover | 37 |
| | | | 6.1.9 | To Clean the Condensate Trap | 37 |
| 3 | PRE-INSTALLATION | 8 | 6.2 | Setting the air/gas ratio | 38 |
| 3.1 | Cleaning primary systems | 8 | 6.3 | Replacement of parts | 39 |
| 3.2 | Mains supply | 9 | 6.4 | Short parts list | 44 |
| 3.2.1 | Electrical supply | 9 | | | |
| 3.2.2 | Gas supply | 9 | 7 | FAULT FINDING & DIAGNOSIS | 45 |
| 3.3 | Water systems & pipe work | 9 | 7.1 | Fault finding | 45 |
| 3.4 | Condensate pipe work | 11 | 7.2 | Protection function (external pump) | 45 |
| 3.4.1 | Internal connections | 11 | 7.3 | Heating function | 46 |
| 3.4.2 | External connections | 12 | | | |
| 3.5 | Boiler internal drain | 13 | | | |
| 3.6 | Boiler location & clearances | 13 | | | |
| 3.7 | Plumbing manifold | 14 | | | |
| 3.8 | Flue options | 15 | | | |
| 3.9 | Flue terminal positions | 17 | | | |
| 3.10 | Plume management terminal positions | 18 | | | |
| 4 | INSTALLATION | 19 | | | |
| 4.1 | Unpacking wall frame and ancillary items | 19 | | | |
| 4.2 | Wall mounting plate and flue opening | 20 | | | |
| 4.3 | Unpacking the appliance | 21 | | | |
| 4.4 | Fitting the appliance boiler connections | 22 | | | |
| 4.5 | Flue installation | 24 | | | |
| 4.5.1 | Ø60/100mm Telescopic flue kit: | 24 | | | |
| 4.5.2 | Ø60mm Plume management kit: | 24 | | | |
| 4.5.3 | Adjusting the standard terminal length: | 24 | | | |
| 4.5.4 | Installing the standard flue | 25 | | | |
| 4.5.5 | Flue terminal plume re-direction: | 25 | | | |
| 4.6 | Condensate connection | 26 | | | |
| 4.7 | Electrical | 26 | | | |
| 4.8 | Position of wired components | 28 | | | |
| 5 | COMMISSIONING | 29 | | | |
| 5.1 | Pre-commissioning checks | 29 | | | |
| 5.2 | Condensate connection | 29 | | | |
| 5.3 | Filling the system | 29 | | | |
| 5.4 | Starting the appliance | 30 | | | |
| 5.5 | Water treatment | 30 | | | |
| 5.6 | Commissioning | 30 | | | |
| 5.6.1 | Checking the gas inlet pressure | 31 | | | |
| 5.6.2 | Checking the gas rate | 31 | | | |
| 5.7 | CO and Combustion checks | 32 | | | |
| 5.8 | Finishing commissioning | 33 | | | |

1 KEY TO SYMBOLS AND SAFETY PRECAUTIONS

1.1 Key to symbols

Warnings

| | |
|-----------------------------------------------------------------------------------|-------------------------------------------------------------------------------------------------------------------------------------------------------------------------------------------------------------------------------------------|
|  | Warnings in this document are identified by a warning triangle printed against a grey background. Keywords at the start of a warning indicate the type and seriousness of the ensuing risk if measures to prevent the risk are not taken. |
|-----------------------------------------------------------------------------------|-------------------------------------------------------------------------------------------------------------------------------------------------------------------------------------------------------------------------------------------|

The following keywords are defined and can be used in this document:

- **NOTE** indicates a situation that could result in damage to property or equipment.
- **CAUTION** indicates a situation that could result in minor to medium injury.
- **WARNING** indicates a situation that could result in severe injury or death.
- **DANGER** indicates a situation that will result in severe injury or death.

Important information

| | |
|-----------------------------------------------------------------------------------|-------------------------------------------------------------------------------------------|
|  | This symbol indicates important information where there is no risk to people or property. |
|-----------------------------------------------------------------------------------|-------------------------------------------------------------------------------------------|

Additional symbols

| Symbol | Explanation |
|--------|-------------------------------------------------|
| ▶ | Step in an action sequence |
| → | Cross-reference to another part of the document |
| • | List entry |
| – | List entry (second level) |

SYMBOLS USED IN THIS MANUAL







| | |
|-------------------------------------------------------------------------------------|----------------------------|
|  | Domestic Hot Water |
|  | Central Heating |
|  | Hot Water Storage Cylinder |
|  | Domestic Cold Water Supply |
|  | Electrical Supply |
|  | Gas Supply |

Table 1 Commonly used symbols

PLEASE READ THESE INSTRUCTIONS CAREFULLY BEFORE STARTING INSTALLATION.

These instructions are applicable to the Worcester appliance model(s) stated on the front cover of this manual only and must not be used with any other make or model of appliance.

These instructions apply in the UK and Ireland only and must be followed except for any statutory obligations.

This appliance must be installed by a **GAS SAFE** registered, competent person. Failure to install correctly could lead to prosecution.

If you are in any doubt, contact the Worcester Technical help-line (0330 123 3366).

Please leave these instructions with the completed BENCHMARK CHECKLIST, (or a certificate confirming compliance with IS 813, Eire only) and the user manual with the owner or at the gas meter after installation or servicing.

Distance learning and training courses are available from Worcester.

The BENCHMARK CHECKLIST can be found in the back of this Installation manual.

| | |
|--------|-----------------------------------------------------|
| ∅ | Diameter |
| NG | Natural Gas |
| LPG | Liquid Petroleum Gas |
| CH | Central Heating |
| DHW | Domestic Hot Water |
| DCW | Domestic Cold Water |
| PRV | Pressure Relief Valve |
| NTC | Negative Temperature Coefficient (sensor) |
| IP | Ingress Protection |
| RCD | Residual Current Device |
| TRV | Thermostatic Radiator Valve |
| ECV | Emergency Control Valve |
| WRAS | Water Regulations Advisory Scheme |
| SEDBUK | Seasonal Efficiency of Domestic Boilers in the U.K. |

Table 2 Abbreviations use in this manual

1.2 SAFETY PRECAUTIONS

If you smell gas

A gas leak could potentially cause an explosion. If you smell gas, observe the following rules.

- ▶ Prevent flames or sparks:
 - Do not smoke, use a lighter or strike matches.
 - Do not operate any electrical switches or unplug any equipment.
 - Do not use the telephone or ring doorbells.
- ▶ Turn off the gas at the meter.
- ▶ Open windows and doors.
- ▶ Warn your neighbours and leave the building.
- ▶ Prevent anyone from entering the building.
- ▶ Well away from the building: call the National Gas Emergency Service on 0800 111 999.

BOILER OPERATION:

This boiler must only be operated by a responsible adult who has been instructed in, understands and is aware of the boiler's operating conditions and effects.



Benchmark places responsibilities on both manufacturers and installers. The purpose is to ensure that customers are provided with the correct equipment for

their needs, that it is installed, commissioned and serviced in accordance with the manufacturer's instructions by competent persons and that it meets the requirements of the appropriate Building Regulations. The Benchmark Checklist can be used to demonstrate compliance with Building Regulations and should be provided to the customer for future reference.

Installers are required to carry out installation, commissioning and servicing work in accordance with the Benchmark Code of Practice which is available from the Heating and Hot water Industry Council who manage and promote the scheme.

Visit centralheating.co.uk for more information.

HEALTH AND SAFETY

The appliance contains no asbestos and no substances have been used in the construction process that contravene the COSHH Regulations (Control of Substances Hazardous to Health Regulations 1988).

COMBUSTIBLE AND CORROSIVE MATERIALS:

Do not store or use any combustible materials (paper, thinners, paints etc.) inside or within the vicinity of the boiler.

Chemically aggressive substances can corrode the appliance and invalidate any warranty.

FITTING & MODIFICATIONS

Fitting the appliance and any controls to the appliance may only be carried out by a competent engineer in accordance with the current Gas Safety (Installation and Use) Regulations.

Flue systems must not be modified in any way other than as described in the fitting instructions. Any misuse or unauthorised modifications to the appliance, flue or associated components and systems could invalidate the warranty. The manufacturer accepts no liability arising from any such actions, excluding statutory rights.

SERVICING

Advise the user to have the system serviced annually by a competent, qualified Gas Safe registered engineer. Approved spares must be used to help maintain the economy, safety and reliability of the appliance.

IMPORTANT

The service engineer must complete the Service Record on the Benchmark Checklist after each service.

INSTALLATION REGULATIONS

Current Gas Safety (Installation & Use) Regulations:

All gas appliances must be installed by a competent person in accordance with the above regulations. Failure to install appliances correctly could lead to prosecution.

The appliance must be installed in accordance with, and comply to, the current: Gas Safety Regulations, IET Regulations, Building Regulations (England), Building Standards (Scotland) (Consolidation), Building Regulations (Wales), Building Regulations (Northern Ireland), local water by-laws, Health & Safety Document 635 (The Electricity at Work Regulations 1989) and any other local requirements.

EU Regulations No. 811/2013 - Energy Labelling.

British Standards:

Where no specific instruction is given, reference should be made to the relevant British Standard codes of Practice.

BS7074:1 - Code of practice for domestic and hot water supply

BS6891I - Installation of low pressure gas pipe work up to 28mm (R1)

BS5546 - Installation of gas hot water supplies for domestic purposes

EN12828 - Central heating for domestic premises

BS5440:1 - Flues and ventilation for gas appliances of rated heating not exceeding 70kW (net): Flues

BS5440:2 - Flues and ventilation for gas appliances of rated heating not exceeding 70kW (net): Air Supply

BS7593 - Treatment of water in domestic hot water central heating systems

BS6798 - Installation of gas fired boilers of rated input up to 70kW (net)

Irish Standards

The relevant Irish standards should be followed, including:

- ECTI National rules for electrical installations
- IS 813:2002 for Domestic Gas Installations.

LPG Installations

An appliance using L.P.G. must not be installed in a room or internal space below ground level unless one side of the building is open to the ground.

Timber framed building:

Where the boiler is to be fitted to a timber framed building the guidelines laid down in BS5440: Part 1 and IGE "Gas Installations in Timber Frame Buildings" should be adhered to.

Potable water:

All seals, joints and compounds (including flux and solder) and components used as part of the secondary domestic water system must be approved by WRAS.

CH Water:

Artificially softened water must not be used to fill the central heating system.

2 APPLIANCE INFORMATION

2.1 General information

Boiler features and checklist

- Pre-plumbed
- Galvanised steel inner frame
- Digital control system
- Automatic ignition
- Direct burner ignition electrodes
- Built-in frost protection
- Built-in fault finding diagnostics
- Automatic gas valve
- Modulating combustion air fan with speed regulator
- CH temperature sensor & control
- Pump anti-seizure protection
- Flue gas temperature sensor
- Condensate siphonic trap

Standard package

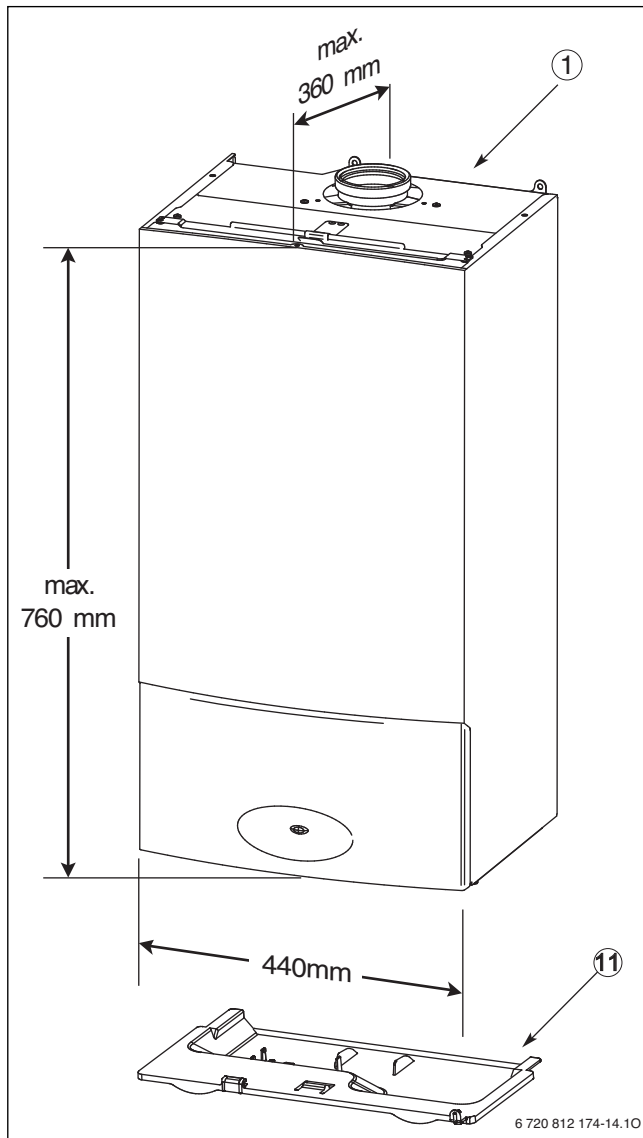

Fig. 1 Overall dimensions

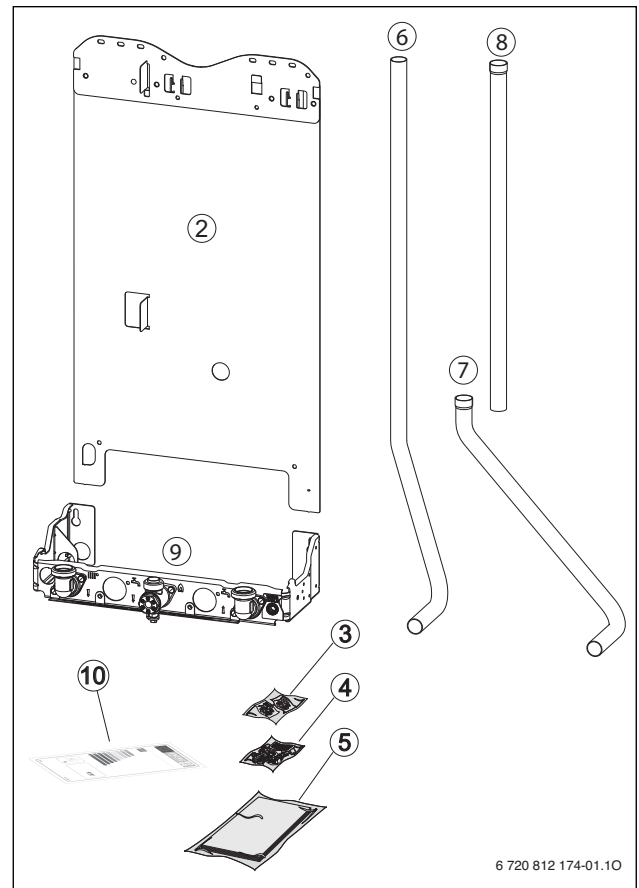

Fig. 2 Standard package

Key to Fig. 1 and 2:

- [1] Wall hung gas fired condensing regular boiler for central heating and domestic hot water
- [2] Wall mounting plate with hanging bracket
- [3] Hardware pack 1
- [4] Hardware pack 2
- [5] Literature pack:
Installation instructions
User instructions
Wall mounting template
- [6] Flow pipe
- [7] Return pipe 1
- [8] Return pipe 2
- [9] Pre-plumbing manifold with water and gas connections
- [10] ErP energy label
- [11] Bottom panels

2.2 TECHNICAL DATA

| Product type | | NATURAL GAS | | L.P.G | |
|------------------------------------------------------|-------------------|--------------------------------------|--------------------------------------|--------------------------------------|--------------------------------------|
| | | 30CDi Classic Regular ^{ErP} | 40CDi Classic Regular ^{ErP} | 30CDi Classic Regular ^{ErP} | 40CDi Classic Regular ^{ErP} |
| Heating | | | | | |
| Max. rated heat input | kW | 30.9 | 42.0 | 30.9 | 42.0 |
| Max. rated heat output net 40/30°C | kW | 32.1 | 43.7 | 32.1 | 43.7 |
| Max. rated heat output net 50/30°C | kW | 31.8 | 43.3 | 31.8 | 43.3 |
| Max. rated heat output net 80/60°C | kW | 30.0 | 40.8 | 30.0 | 40.8 |
| Min. rated heat output net 40/30°C | kW | 8.6 | 10.6 | 12.4 | 15.7 |
| Min. rated heat output net 50/30°C | kW | 8.6 | 10.5 | 12.3 | 15.5 |
| Min. rated heat output net 80/60°C | kW | 7.7 | 9.4 | 11.0 | 13.9 |
| Min. rated heat input net | kW | 8.0 | 9.8 | 11.5 | 14.5 |
| Max. flow temperature | °C | nom.90 | nom.90 | nom.90 | nom.90 |
| Max. permissible operating pressure | bar | 2.5 | 2.5 | 2.5 | 2.5 |
| Gas flow rate - Max. 10 minutes from lighting | | | | | |
| Natural Gas G20 | m ³ /h | 3.2 | 4.4 | - | - |
| Propane Gas (LPG) | kg/h | - | - | 2.4 | 3.3 |
| Flue | | | | | |
| Flue Gas Temp. 80/60°C, rated min. load Max/Min | °C | 76/58 | 87/58 | 76/58 | 87/58 |
| Flue Gas Temp. 40/30°C, rated min. load Max/Min | °C | 55/33 | 58/35 | 55/33 | 58/35 |
| CO ₂ level at max. rated heat output | % | 9.6 | 9.7 | 11.5 | 11.5 |
| CO ₂ level at min. rated heat output | % | 9.0 | 9.1 | 10.5 | 10.5 |
| NO _x - class | | 5 | 5 | 5 | 5 |
| Condensate | | | | | |
| Max. condensation rate | l/h | 2.7 | 3.7 | 2.7 | 3.7 |
| pH value, approx. | | 4.8 | 4.8 | 4.8 | 4.8 |
| Electrical | | | | | |
| Electrical power supply voltage | AC...V | 230 | 230 | 230 | 230 |
| Frequency | Hz | 50 | 50 | 50 | 50 |
| Max. power consumption | W | approx.70 | approx.100 | approx.70 | approx.100 |
| General Data | | | | | |
| SEDBUK | band | A | A | A | A |
| Appliance protection rating | IP | X4D | X4D | X4D | X4D |
| Permissible ambient temperatures | °C | 0-50 | 0-50 | 0-50 | 0-50 |
| Nominal capacity of appliance | l | 3.5 | 3.5 | 3.5 | 3.5 |
| Total boiler weight (lift weight) | kg | 39.5 | 39.5 | 39.5 | 39.5 |
| Packaged boiler weight | kg | 48 | 48 | 48 | 48 |
| SAP 2009 annual efficiency | % | 89.2 | 89.2 | 90.2 | 90.2 |
| SAP 2005 seasonal efficiency (SEDBUK) | % | 90.2 | 90.1 | 92.1 | 92.0 |

Table 3 Technical data

2.3 Product data on energy consumption

The following product data satisfy the requirements of the EU Regulations No. 811/2013, No. 812/2013, No. 813/2013 and No. 814/2013 supplementing Directive 2010/30/EU.

| Product data | Symbol | Unit | 7 738 100 245 | 7 738 100 235 | 7 738 100 232 | 7 738 100 234 |
|-----------------------------------------------------------------------|--------------------|--------|--------------------------------------|------------------------------------------|--------------------------------------|------------------------------------------|
| Product type | - | - | 30CDi Classic Regular ^{ErP} | 30CDi Classic Regular ^{ErP} LPG | 40CDi Classic Regular ^{ErP} | 40CDi Classic Regular ^{ErP} LPG |
| Condensing boiler | - | - | Yes | Yes | Yes | Yes |
| Rated heat output | P _{rated} | kW | 30 | 30 | 41 | 41 |
| Seasonal space heating energy efficiency | η _s | % | 92 | 92 | 92 | 92 |
| Energy efficiency class | - | - | A | A | A | A |
| Useful heat output | | | | | | |
| At rated heat output and high temperature regime ¹⁾ | P ₄ | kW | 30.0 | 30.0 | 40.8 | 40.8 |
| At 30 % of rated heat output and low temperature regime ²⁾ | P ₁ | kW | 10.0 | 10.0 | 13.6 | 13.6 |
| Useful efficiency | | | | | | |
| At rated heat output and high temperature regime ¹⁾ | η ₄ | % | 88.2 | 88.2 | 88.2 | 88.2 |
| At 30 % of rated heat output and low temperature regime ²⁾ | η ₁ | % | 97.5 | 97.5 | 96.9 | 96.9 |
| Auxiliary electricity consumption | | | | | | |
| At full load | e _{lmax} | kW | 0.058 | 0.058 | 0.090 | 0.090 |
| At part load | e _{lmin} | kW | 0.030 | 0.030 | 0.036 | 0.036 |
| In standby mode | P _{SB} | kW | 0.004 | 0.004 | 0.004 | 0.004 |
| Other items | | | | | | |
| Standby heat loss | P _{stby} | kW | 0.048 | 0.048 | 0.048 | 0.048 |
| Emissions of nitrogen oxides | NO _x | mg/kWh | 30 | 30 | 29 | 29 |
| Sound power level, indoors | L _{WA} | dB(A) | 55 | 55 | 60 | 60 |

Table 4 Product data for energy consumption

- 1) High temperature regime means 60 °C return temperature at heater inlet and 80 °C feed temperature at heater outlet.
- 2) Low temperature means for condensing boilers 30 °C, for low-temperature boilers 37 °C and for other heaters 50 °C return temperature (at heater inlet).

2.4 Layout & components

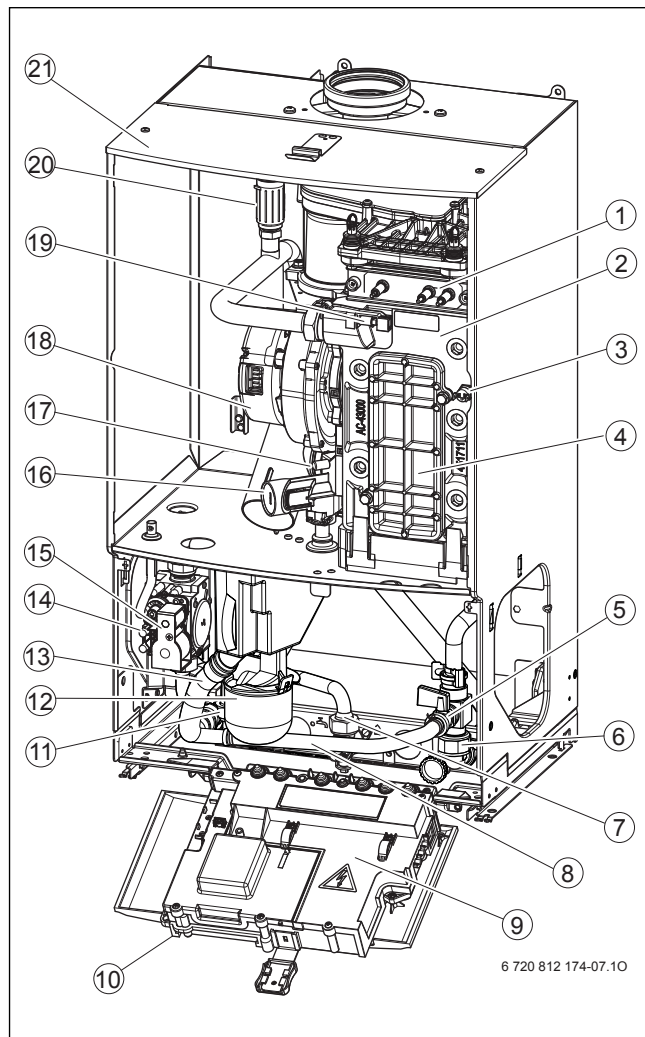

Fig. 3 Boiler layout and components. The diagram shows the controls in the servicing position and excludes the outer case.

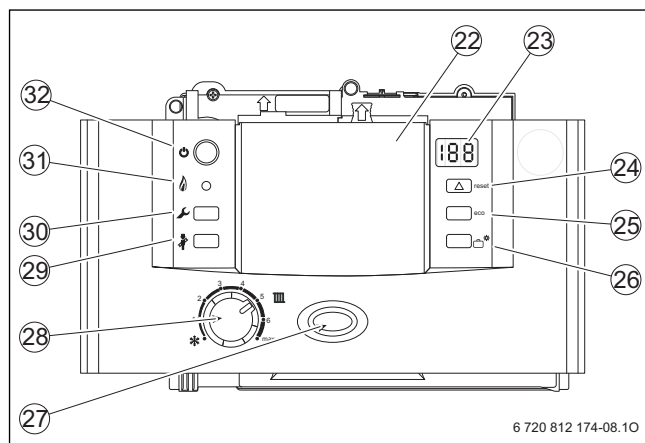

Fig. 4

- [1] Ignition electrode and flame sense electrode
- [2] Heat exchanger
- [3] Overheat thermostat
- [4] Access point for cleaning heat exchanger
- [5] Drain point
- [6] Return
- [7] Gas connection 22 mm compression
- [8] Drain hose
- [9] Cover for external wiring connection
- [10] Control panel in service position

- [11] Flow
- [12] Trap / Siphon
- [13] Condensate hose (22 mm outlet connection)
- [14] Inlet pressure test point
- [15] Gas valve
- [16] Air/gas adjustment screw
- [17] Testing point for fan pressure
- [18] Fan
- [19] Primary sensor
- [20] Auto air vent
- [21] Removable top case for servicing
- [22] Blank plate
- [23] Display
- [24] Fault reset button
- [25] Not used
- [26] Not used
- [27] ON/OFF and fault indicator (blue)
- [28] Temperature control
- [29] Performance test button
- [30] Service button
- [31] Burner indicator (green)
- [32] ON/OFF button

The diagram above shows the controls in the servicing position and excludes the outer case.

3 PRE-INSTALLATION

3.1 Cleaning primary systems



NOTICE:

► All the following Pre-Installation sections must be read and requirements met before starting boiler or flue installations.



CAUTION:

► ISOLATE THE MAINS SUPPLIES BEFORE STARTING ANY WORK AND OBSERVE ALL RELEVANT SAFETY PRECAUTIONS.



NOTICE:

Debris from the system can damage the boiler and reduce efficiency. Failure to comply with the guidelines for the use of water treatment with the appliance will invalidate the appliance warranty.

BEFORE CLEANING THE SYSTEM:

- Ensure that the system and pipe work is in good working order.
- Where possible keep the existing boiler/circulating pump in place when flushing the system.

FOLLOW THE GUIDANCE OF BS7593:

Treatment of water in domestic hot water central heating and also the flushing guidelines below.



NOTICE: ARTIFICIALLY SOFTENED WATER MUST NOT BE USED TO FILL THE CENTRAL HEATING SYSTEM.

FLUSHING THE SYSTEM

- Fill the system with cold water and check for leaks.
- Open all drain cocks and drain the system.
- Close drain cocks and add a suitable flushing agent **compatible with aluminium** at the correct strength for the system conditions in accordance with the manufacturer's instructions.
The pH value of the system water must be less than 8 or the appliance guarantee will be invalidated.
- Circulate the flushing agent before the boiler is fired up.

- ▶ Run the boiler/system at normal operating temperature as directed by the manufacturer of the flushing agent.
- ▶ Drain and thoroughly flush the system to remove the flushing agent and debris.
- ▶ It may be necessary to use a power flushing machine to aid the cleansing procedure in some circumstances.
- ▶ Close the drain cocks and refill with fresh water and a suitable inhibitor.
- ▶ Vent any air from the boiler and system.

INHIBITOR

Add a suitable inhibitor or combined inhibitor/anti-freeze, if the system is exposed to freezing conditions, to the heating system in accordance with the DWTA code of practice and manufacturer's guidelines.

| | |
|-----------------------------------------------------------------------------------|------------------------------------------------------------------------------------------------------------------------------------------------------------------------------------------------------------------------------------|
|  | <p>WARNING: Sealing agents</p> <ul style="list-style-type: none"> ▶ The addition of sealing agents to the system water is not permitted as this can cause problems with deposits left in the heat exchanger. |
|-----------------------------------------------------------------------------------|------------------------------------------------------------------------------------------------------------------------------------------------------------------------------------------------------------------------------------|

Water treatment

Suitable water treatment products can be obtain from the following manufacturers:

| | |
|----------|---------------------------------------------|
| FERNOX | 0870 601 5000 www.fernox.com |
| SENTINEL | 0800 389 4670 www.sentinel-solutions.net |

3.2 MAINS SUPPLY

3.2.1 Electrical supply

- Supply: 230V - 50 Hz, 140 Watts
- Cable: PVC insulated 0.75 mm² (24 x 0.2 mm) temperature rated to 90°C.
- External 3A fuse to BS1362.
- The appliance must be earthed.
- This appliance must not be connected to a three phase supply.
- IPX4D.
- Wiring must comply with the latest IET wiring regulations.

3.2.2 Gas supply

- Boilers using Natural Gas (NG) must be connected to a governed meter.
- Liquid Petroleum Gas (LPG) must be connected to a regulator.
- Installation and connection of the gas supply to the boiler must be in accordance with BS6891.
- Under no circumstance should be size of the gas supply pipe be less than 22 mm.
- The meter or regulator and pipe work to the meter must be checked, preferably by the gas supplier. This is to ensure that the equipment is in good working order and can meet the gas flow and pressure requirements, in addition to the demand from any other appliance being served.

3.3 WATER SYSTEMS & PIPE WORK

PLASTIC PIPEWORK:

- Any plastic pipe work must have a polymeric barrier with 600 mm (minimum) length of copper or steel pipe connected to the boiler.
- Plastic pipe work used for underfloor heating must be correctly controlled with a thermostatic blending valve limiting the temperature of the circuits to approximately 50°C. The pipe work from the boiler to the blending valve must be in copper or steel (protected from corrosion).

CONNECTIONS/VALVES:

- All system connections, taps and mixing valves must be capable of sustaining a pressure up to 3 bar.
- Radiator valves should conform to BS2767:10.
- Do not use galvanised pipes or radiators.
- All other valves should conform to BS1010.
- On new installations, or extensions to existing systems where a radiator previously did not exist, each radiator should be fitted with a TRV, except the one fitted in the same room/area as the room thermostat.
- On boiler only replacement jobs, it is recommended, (but not mandatory,) to fit a TRV on each radiator. It is, however, a requirement, for energy conservation purposes, to recommend to the customer that a TRV is fitted to each radiator.
- An automatic bypass may be required, (downstream of the pump), in order to maintain the minimum flow-rate through the appliance.
- An air vent is required at the highest point on the system.

SEALED PRIMARY SYSTEM:

| | |
|-------------------------------------------------------------------------------------|--------------------------------------------------------------------------------------------------------|
|  | <p>NOTICE: Artificially softened water must not be used to fill the central heating system.</p> |
|-------------------------------------------------------------------------------------|--------------------------------------------------------------------------------------------------------|

- The CH sealed system must be filled using a WRAS approved filling loop or comply with figure 5 for system fill.
- An expansion vessel, of a size suitable for the system, must be fitted as close as possible to the appliance in the central heating return.
- Also fit a pressure gauge, a 3 bar pressure relief valve and stop cock (fixed cylinder type or sealed system approved connection).
- **Do not use galvanised pipes or radiators.**

SYSTEM FILL

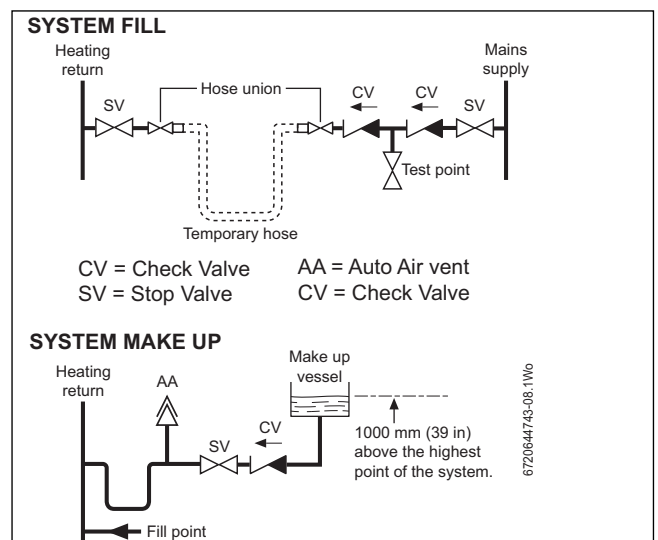

Fig. 5 System fill/System make up

S AND Y PLAN SYSTEM:

NOTICE: Bypass
 ► Generally a bypass is not necessary on a Y plan system as one of the ports is open to flow.

| | |
|----|---------------------------------------------------------------------------------------------------------------------------------------------------------------------------------------------------------------------------|
| 1 | Static head - Minimum static head 250mm measured from the highest point in the heating system (top surface of the appliance or the highest point in the heating system) to the water level in the feed and expansion tank |
| 2 | Heating vent (22mm minimum) |
| 3 | Primary cold feed (15mm minimum) |
| 4 | Diverter/Zone valve |
| 5 | Pump, maximum power 90 Watts |
| 6 | Automatic bypass |
| 7 | Radiator valve (Flow) |
| 8 | Lock shield valve (Return) |
| 9 | Expansion vessel |
| 10 | Pressure gauge |
| 11 | 3 bar pressure relief valve |
| 12 | Stop cock |

Table 5 Key to figures 7, 8, 9 & 10

NOTICE: A drain cock should be fitted at the lowest point of the heating circuit and beneath the appliance.

system layout:

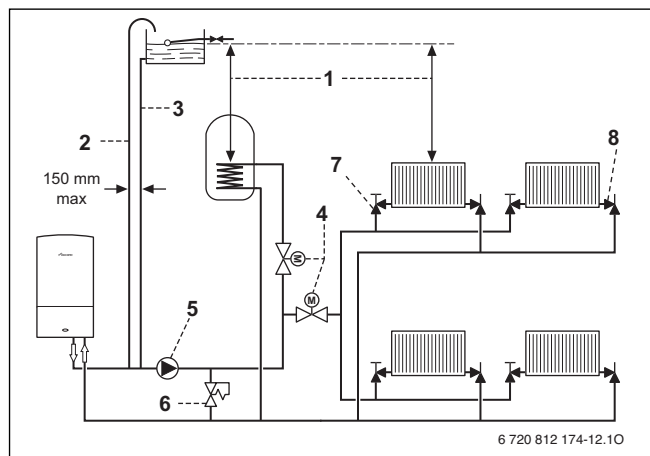

Fig. 6 S plan

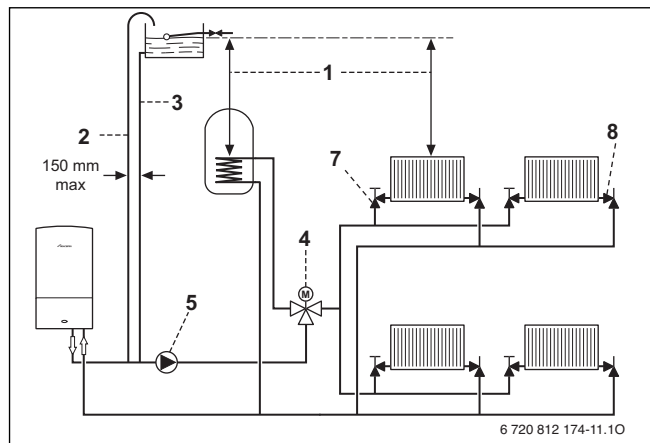

Fig. 7 Y plan

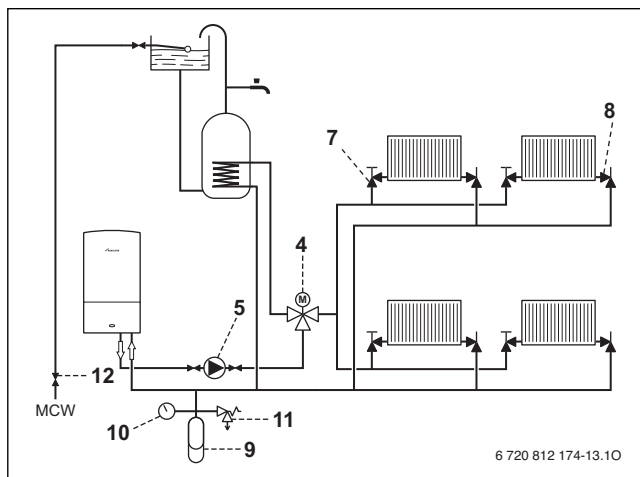

Fig. 8 Sealed system

new build system layouts

The latest Part L1a regulation for new installations require separate zone controls for the central heating.

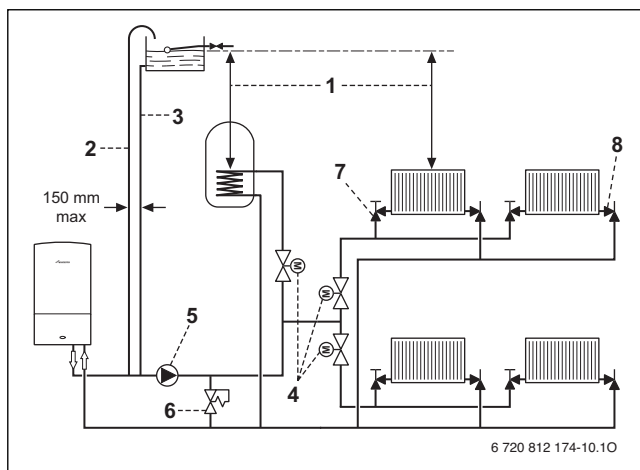

Fig. 9 Open vent with two heating zones

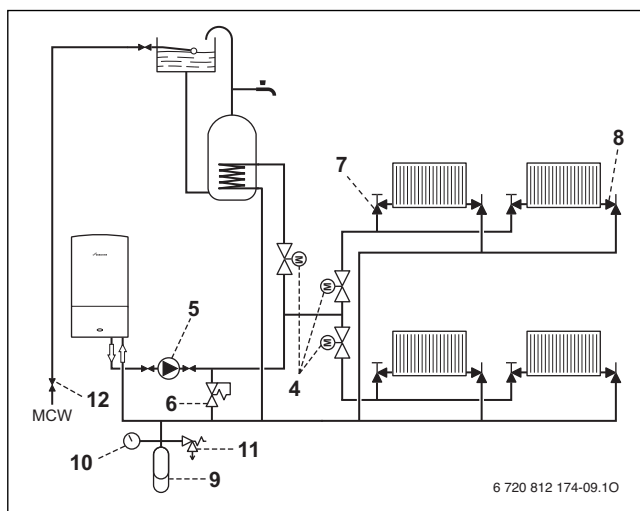

Fig. 10 Sealed system with two heating zones

3.4 Condensate pipe work

NOTICE:

- ▶ Where a new or replacement boiler is being installed, access to an internal "gravity discharge" point should be one of the factors considered in determining boiler location.
- ▶ The condensate pipe must be nominally 22mm Ø plastic pipe.
- ▶ The condensate pipe work must fall at least 52mm per metre towards the outlet and should take the shortest practicable route.
- ▶ Ensure there are no blockages in the pipe run.

| Key to condensate illustrations | |
|---------------------------------|--------------------------------------------------------------|
| 1 | Condensate discharge from boiler |
| 2 | Soil and vent stack |
| 3 | Minimum 450mm and up to three storeys |
| 4 | Visible air break at plug hole |
| 5 | Sink or basin with integrated overflow |
| 6 | 75mm sink waste trap |
| 7 | Condensate pump |
| * | Condensate trap of 75mm already incorporated into the boiler |

3.4.1 Internal connections

In order to minimise risk of freezing during prolonged cold spells, the following methods of installing condensate drainage pipe should be adopted, in order of priority.

Wherever possible, the condensate drainage pipe should be routed and terminated so that the condensate drains away from the boiler under gravity to a suitable internal foul water discharge point such as an internal soil and vent stack. A suitable permanent connection to the foul waste pipe should be used.

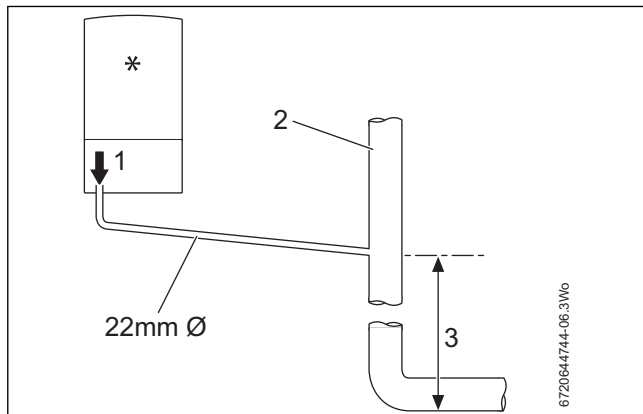

Fig. 11 Disposal to soil vent stack

Alternatively if the first option is not possible an internal kitchen or bathroom waste pipe, washing machine waste pipe etc. can be used. Ensure that the condensate drain pipe is connected "down stream" of the waste trap.

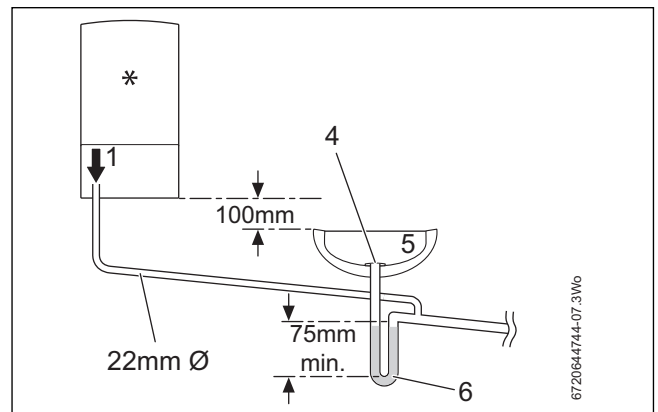

Fig. 12 Disposal to a waste pipe

CONDENSATE PUMP

Where "gravity discharge" to an internal termination is not physically possible, or where very long internal runs would be required to reach a suitable discharge point, condensate should be removed using a proprietary condensate pump, of a specification recommended by the boiler or condensate pump manufacturer.

The pump outlet pipe should discharge to a suitable internal foul water discharge point such as an internal soil and vent stack, internal kitchen or bathroom waste pipe, washing machine waste pipe etc. A suitable permanent connection to the foul waste pipe should be used.

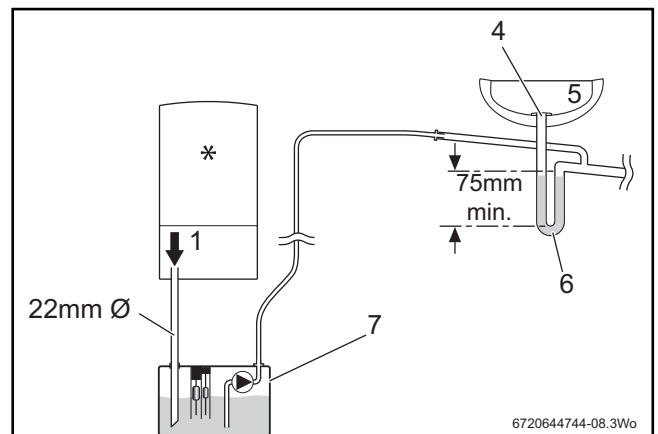

Fig. 13 Condensate pump disposal

3.4.2 External connections

NOTICE: Freezing conditions

- ▶ When the position of the boiler prevents internal routing, we recommend installing a CondenseSure siphon to significantly reduce the risk of freezing.
- ▶ Pipe work length should be kept to a minimum and the route as vertical as possible.
- ▶ Weather proof insulation must be used, if not using a CondenseSure siphon.

NOTICE: Condensate waste

- ▶ Care should be taken when siting a soak-away to avoid obstructing existing services.

| Continued - Key to condensate illustrations | |
|---------------------------------------------|--------------------------------------------------------------|
| 8 | PVCu strap on fitting |
| 9 | 100mm Ø minimum plastic pipe |
| 10 | Drainage holes |
| 11 | Limestone chippings |
| 12 | Bottom of sealed tube |
| 13 | Insulate and increase pipe size |
| 14 | Pipe work transition |
| 15 | External air break |
| 16 | Air gap |
| 17 | External rain water pipe into foul water |
| 18 | 43mm 90° male/female bend |
| * | Condensate trap of 75mm already incorporated into the boiler |

If no other discharge method is possible then the use of an externally run condensate drainage pipe terminating at a suitable foul water discharge point, or purpose-designed soak away, may be considered. If this method is chosen then the following measures should be adopted:

- ▶ Use a CondenseSure siphon to help prevent the condensate freezing.
- ▶ The external run be kept as short as possible and not exceed three metres.
- ▶ The pipe should be run internally as far as possible before going externally and the pipe diameter should be increased to 32mm before it passes through the wall to the exterior. The pipe should be insulated using suitable waterproof and weather resistant insulation, if not using a CondenseSure siphon.
- ▶ The external pipe should take the shortest and least exposed route to the discharge point, and should "fall" as steeply as possible away from the boiler, with no horizontal runs in which condensate might stand.
- ▶ The use of fittings, elbows etc. should be kept to a minimum and any internal "burrs" on cut pipe work should be removed so that the internal pipe section is as smooth as possible.

FITTING AN EXTERNAL AIR BREAK

- Refer to figure 14 when a rain water down pipe is used to dispose of condensate.
- An air break must be installed in the 43mm pipe work, between the boiler condensate outlet and the drainpipe, outside the property, to avoid flooding during adverse weather conditions.

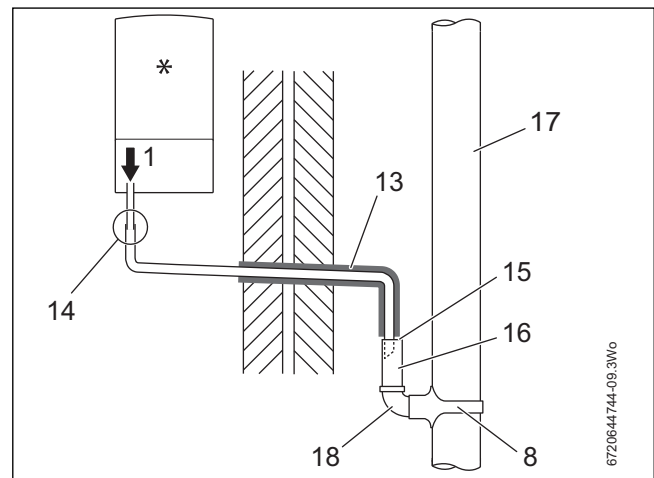

Fig. 14 Disposal into a rainwater down pipe



Condensate drainage pipe can be run above or below ground.

Where the pipe terminates over an open drain or gully, the pipe should terminate below the grating level, but above water level, in order to minimise "wind chill" at the open end.

The use of a drain cover (such as those used to prevent blockage by leaves) may offer further protection from wind chill.

Pipe drainage will be improved if the end is cut at 45° as opposed to a straight cut.

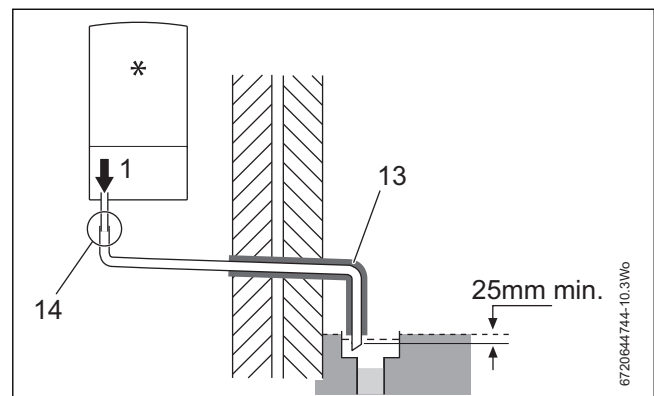

Fig. 15 External disposal

CONDENSATE SOAK AWAY

- The condensate drainage pipe may be run above or below the ground to the soak away. The examples shown on this page run above ground.
- The soak away must use a 100mm Ø plastic tube with two rows of three 12mm holes on 25mm centres and 50mm from the bottom of the tube. The holes must face away from the house.
- The tube must be surrounded by at least 100mm of limestone chippings to a depth of 400mm.



Minimum hole size for the condensate soak away must be 400mm deep by 300mmØ.

In situations where there are likely to be extremes of temperature or exposure, the use of a proprietary trace-heating system for external pipe work, incorporating an external frost thermostat, should be considered. If such a system is used, the requirement to use 32mm pipe does not apply. However, all other guidance above and the instructions for the trace heating system, should be closely followed.



NOTICE: Unheated internal areas.

- ▶ Internal pipe runs in unheated areas such as lofts, basements and garages should be treated as external runs.

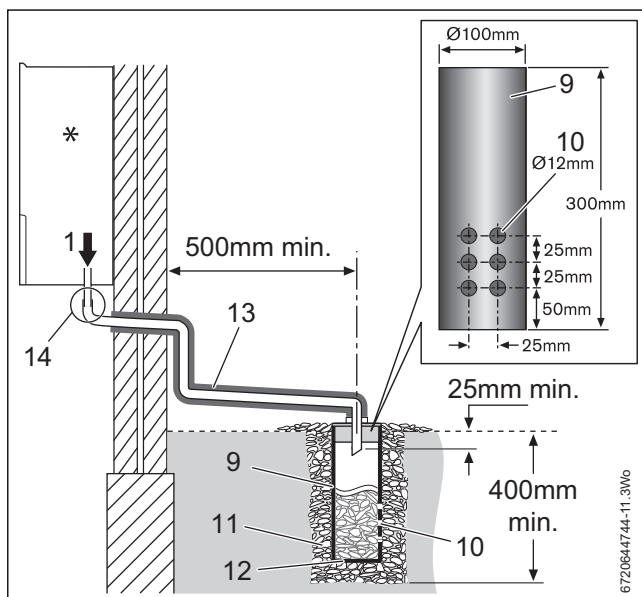

Fig. 16 Soak away

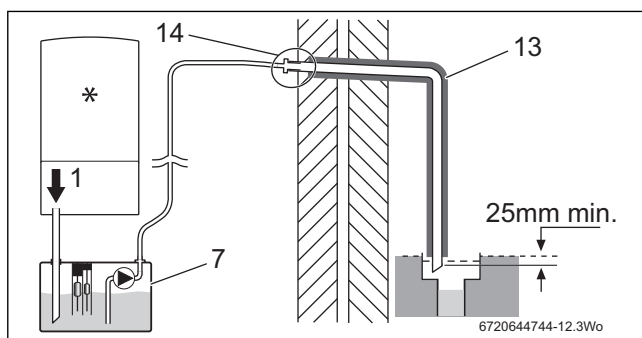

Fig. 17 Condensate pump to external disposal

3.5 Boiler internal drain

The CDI Regular^{ErP} has the facility to drain the water direct from the boiler through the condensate pipe.

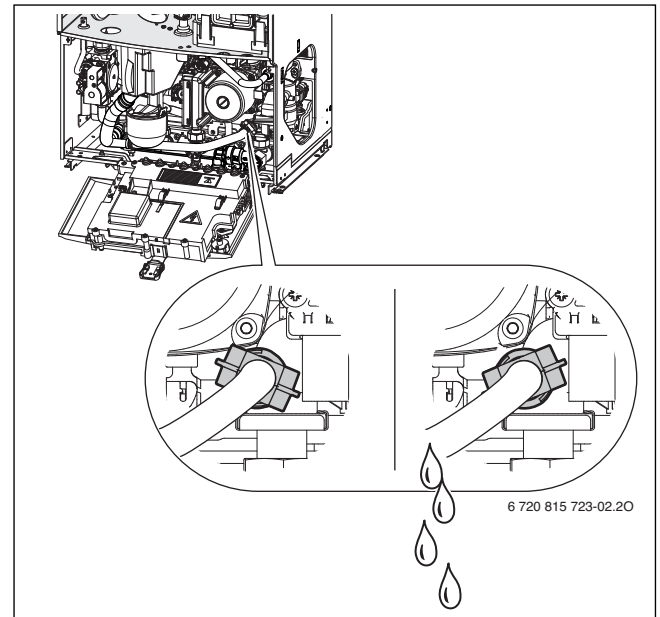

Fig. 18 Drain tap positions

If the boiler uses a soakaway or a condensate pump:

- ▶ Use an external drain point on the system to prevent excess system water being drawn through the soakaway or condensate pump

3.6 Boiler location & clearances

This boiler is only suitable for installing internally within a property at a suitable location onto a fixed, rigid non-combustible surface at least the same size as the boiler and capable of supporting the boiler weight.



NOTICE:

No surface protection is required against heat transfer from the boiler.

COMPARTMENTS:

Follow the requirements of BS6798 and BS5440 Part 2 and note:

- Minimum clearances must be maintained
- An access door is required to install, service and maintain the boiler and any ancillary equipment.
- If an airing cupboard is adapted to house a boiler, then the airing spaces must be separated from the boiler compartment by a noncombustible partition. The partition may be perforated, if required, by holes not exceeding 13 mm in diameter.
- If the appliance is fitted into a cupboard or a compartment is built around the appliance after installation, then the compartment must be built or lined by a non-combustible material.

BOILER CLEARANCES:

The diagram opposite shows the minimum space required to install and service the boiler.

VENTILATION

This is a room sealed appliance and does not require any air for combustion from inside the property.

The requirements of BS 6798 and BS 5440 regarding ventilation do not apply, with the Greenstar CDI Regular^{ErP} boiler. There is no need for ventilation openings to be provided in the compartment because of the low heat loss from the appliance casing, if the clearances shown are maintained.

Do not operate the appliance if the flue terminal fitted on the outside wall or roof is obstructed or damaged.

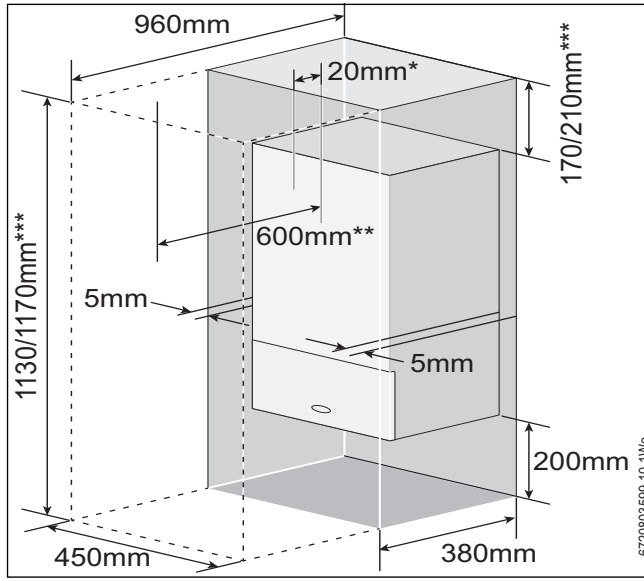

| | |
|-----|------------------------------------------|
| * | Minimum clearance to removable door |
| ** | Minimum clearance required for servicing |
| *** | Height for either 60/100 or 80/125 flue |

Table 6 Minimum clearances

BATHROOMS:

Additional RCD (Residual Current Device) protection may be required. Refer to the latest IET wiring regulations.

NOTICE: Any switch or appliance control using 230 V mains electricity must not be able to be touched by a person using the bath or shower. Electrical switches, fused spur and socket outlets must not be situated in the bathroom.

BATHROOM INSTALLATIONS

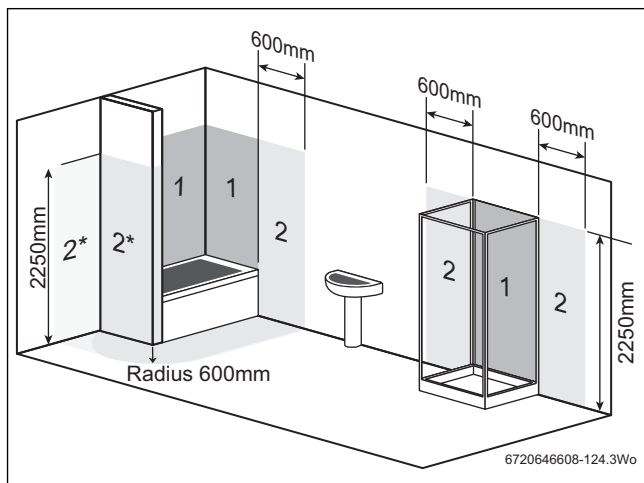

Fig. 19 Bathroom installations

3.7 PLUMBING MANIFOLD

CONNECTIONS:

Heating System: 22mm compression fittings
 Gas: 22mm compression fittings
 Use the fittings supplied in the Hardware pack.

PREPLUMBING

With the plumbing manifold installed, pipe work can be installed to the valves on the manifold.

RUNNING PIPES BEHIND THE BOILER

If the boiler pipes are to be run behind the appliance ensure that the pipes pass close to the wall as shown in the diagram opposite, and within the pipe guide.

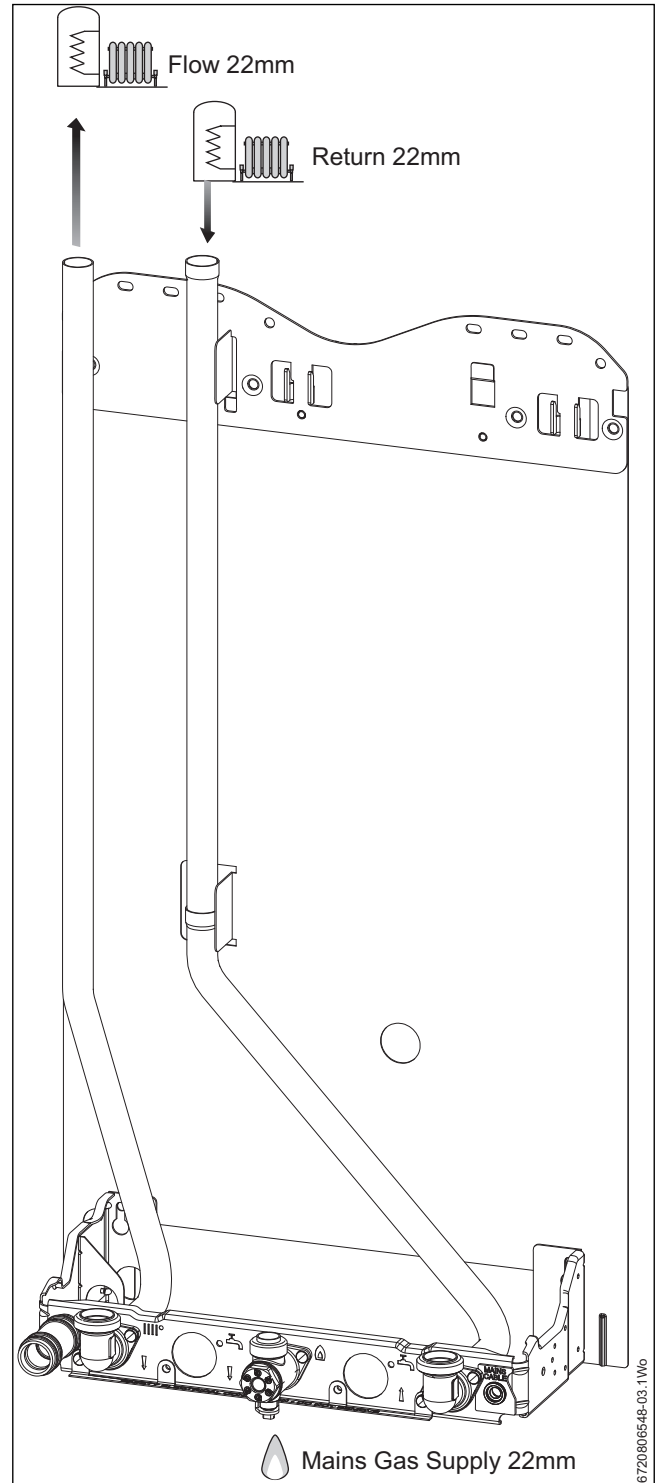

Fig. 20 Behind the boiler pipe run

3.8 Flue options

The Greenstar CDi Classic Regular ^{ErP} has the option of three horizontal RSF (60/100 telescopic, 60/100 longer telescopic and 80/125 telescopic) flue systems and two vertical RSF (60/100 or 80/125) regular flue systems:

The systems have different maximum flue lengths for different boiler outputs and different plume management lengths.

For every extra 1000mm of plume management after the first 500mm, the internal 60/100 flue length must be reduced by 700mm, up to a maximum of 4500mm of plume management.

For example on a 30CDi Classic Regular ^{ErP} if the plume management effective length was 1500mm, the internal flue would be reduced to 5200mm.

| Maximum horizontal flue lengths (L) | | | | |
|-------------------------------------|---------------------|-----------------------------|-----------------------------|-------------------------------|
| Boiler model | 100mmØ | | | 125mmØ |
| | No Plume management | + 500mm of plume management | +4500mm of plume management | No plume management available |
| 30CDi | 7,900mm | 5,900mm | 3,100mm | 18,500mm |
| 40CDi | 6,000mm | 4,000mm | 1,200mm | 12,500mm |

Table 7 Maximum horizontal flue lengths

| Maximum vertical flue lengths | | |
|-------------------------------|---------|----------|
| Boiler model | 100mmØ | 125mmØ |
| 30CDi | 9,400mm | 18,500mm |
| 40CDi | 7,500mm | 16,000mm |

Table 8 Maximum vertical flue lengths

This page and the page opposite shows various flue options with the straight flue lengths required to achieve the maximum flue length.



NOTICE: 60/100 Flue systems:

- ▶ Each 90° bend used is equivalent to 1.5 metres of straight flue.
- ▶ Each 45° bend used is equivalent to 0.75 metres of straight flue.



NOTICE: 80/125 flue systems:

- ▶ Each 90° bend used is equivalent to 2 metres of straight flue.
- ▶ Each 45° bend used is equivalent to 1 metre of straight flue.

| Telescopic horizontal flue | | |
|----------------------------|--------|--------|
| Flue option 1 | 100mmØ | 125mmØ |
| 30CDi | 570mm | 600mm |
| 40CDi | 570mm | 600mm |

Table 9 Flue option 1

| Horizontal extended flue | | |
|--------------------------|---------|----------|
| Flue option 2 | 100mmØ | 125mmØ |
| 30CDi | 7,900mm | 18,500mm |
| 40CDi | 6,000mm | 12,500mm |

Table 10 Flue option 2

| Horizontal extended flue with 1x90° bends | | |
|-------------------------------------------|---------|----------|
| Flue option 3 | 100mmØ | 125mmØ |
| 30CDi | 6,400mm | 16,500mm |
| 40CDi | 4,500mm | 10,500mm |

Table 11 Flue option 3

| Horizontal extended flue with 2x90° bends | | |
|-------------------------------------------|---------|----------|
| Flue option 4 | 100mmØ | 125mmØ |
| 30CDi | 4,900mm | 14,500mm |
| 40CDi | 3,000mm | 8,500mm |

Table 12 Flue option 4

| High level horizontal extended flue | | |
|-------------------------------------|---------|----------|
| Flue option 5 | 100mmØ | 125mmØ |
| 30CDi | 7,900mm | 18,500mm |
| 40CDi | 6,000mm | 12,500mm |

Table 13 Flue option 5

| High level horiz. extended flue with 2x90° bends | | |
|--------------------------------------------------|---------|----------|
| Flue option 6 | 100mmØ | 125mmØ |
| 30CDi | 6,400mm | 16,500mm |
| 40CDi | 4,500mm | 10,500mm |

Table 14 Flue option 6

| High level horiz. extended flue with 3x90° bends | | |
|--------------------------------------------------|---------|----------|
| Flue option 7 | 100mmØ | 125mmØ |
| 30CDi | 4,900mm | 14,500mm |
| 40CDi | 3,000mm | 8,500mm |

Table 15 Flue option 7

| Vertical balanced extended flue | | |
|---------------------------------|---------|----------|
| Flue option 8 | 100mmØ | 125mmØ |
| 30CDi | 9,400mm | 18,500mm |
| 40CDi | 7,500mm | 16,000mm |

Table 16 Flue option 8

| Vertical balanced extended flue with 2x90° bends | | |
|--------------------------------------------------|---------|----------|
| Flue option 9 | 100mmØ | 125mmØ |
| 30CDi | 6,400mm | 14,500mm |
| 40CDi | 4,500mm | 12,000mm |

Table 17 Flue option 9

| Vertical balanced extended flue with 2x45° bends | | |
|--------------------------------------------------|---------|----------|
| Flue option 10 | 100mmØ | 125mmØ |
| 30CDi | 7,900mm | 16,500mm |
| 40CDi | 6,000mm | 14,000mm |

Table 18 Flue option 10

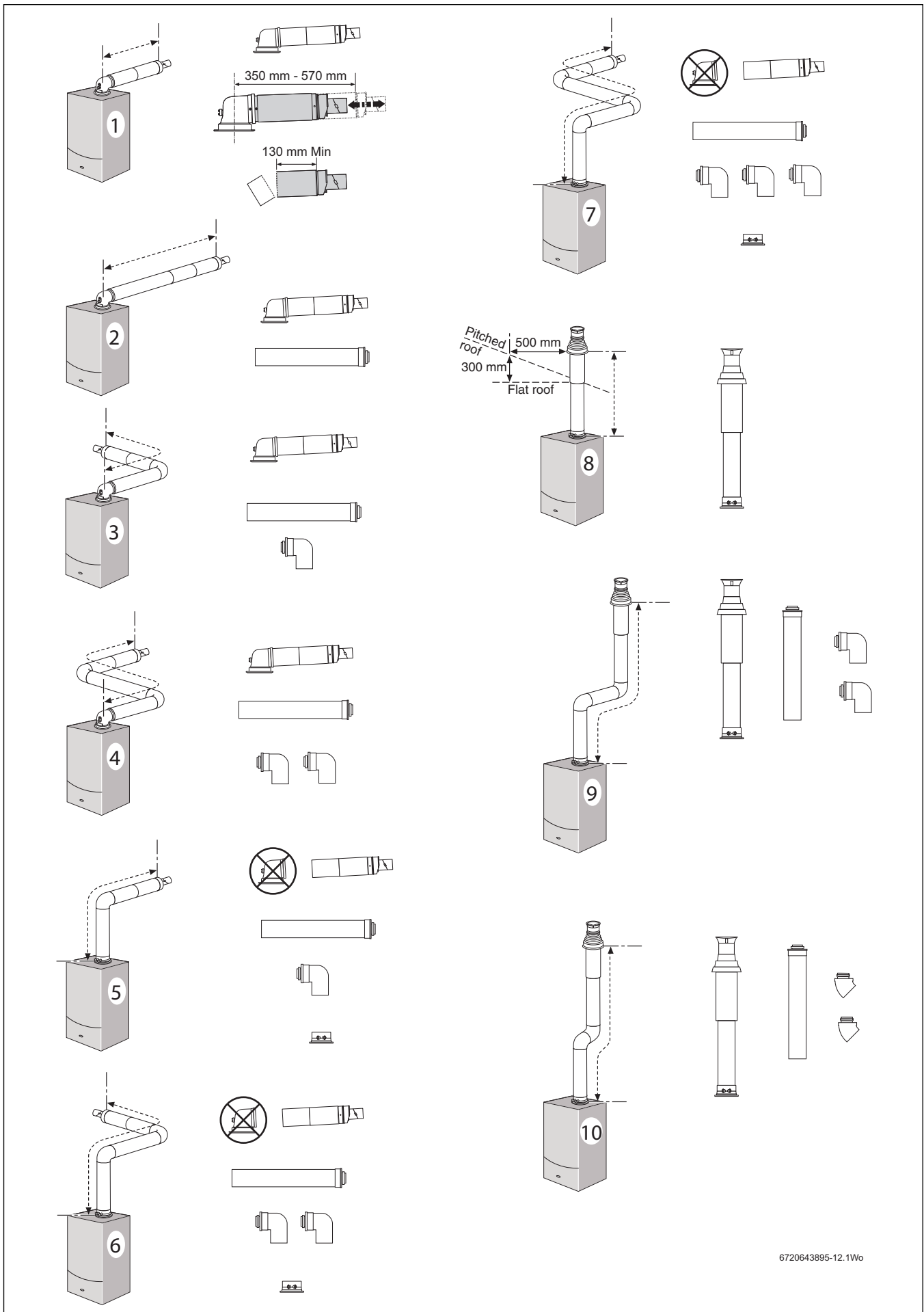

6720643895-12.1Wo

Fig. 21

3.9 Flue terminal positions

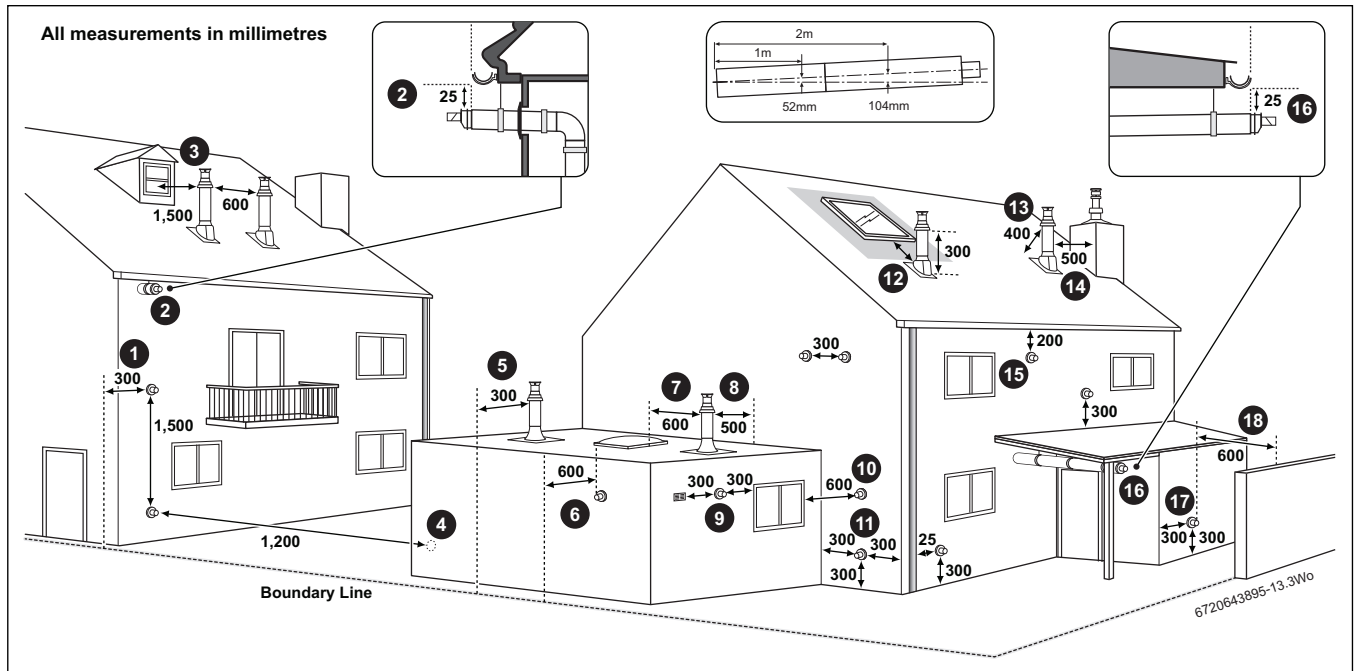

Fig. 22 Flue terminal positions

NOTICE:

- ▶ All measurements are the minimum clearances required.
- ▶ Terminals must be positioned so to avoid combustion products entering the building.
- ▶ Support the flue at approximately one metre intervals and at a change of direction, use suitable brackets and fittings (flue brackets 100mm part number: 7 716 191 177, flue brackets 100mm x 6 part number: 7 716 191 178, flue bracket 125mm part number: 7 716 191 179).

Key to illustration

1. 300mm adjacent to a boundary line.
2. The dimension below eaves, balconies and car ports can be reduced to 25mm, as long as the flue terminal is extended to clear any overhang. External flue joints must be sealed with suitable silicon sealant.
3. 1,500mm between a vertical flue terminal and a window or dormer window.
4. 1,200mm between terminals facing each other.
5. Vertical flue clearance, 300mm adjacent to a boundary line.
6. 600mm distance to a boundary line, unless it will cause a nuisance. BS 5440: Part 1 recommends that care is taken when siting terminal in relation to boundary lines.
7. 600mm minimum clearance from a skylight to a vertical flue.
8. Vertical flue clearance, 500mm to non-combustible building material, and 1,500mm clearance to combustible building material.
9. 300mm above, below and either side of an opening door, air vent or opening window.
10. 600mm diagonally to an opening door, air vent or opening window.
11. 300mm to an internal or external corner.
12. 2,000mm below a Velux window, 600mm above or to either side of the Velux window.
13. 400mm from a pitched roof or 500mm in regions with heavy snow fall.
14. 500mm clearance to any vertical structure on a roof, 600mm to room sealed flue or 1,500 to an open flue.
15. 200mm below eaves and 75mm below gutters, pipe and drains.

16. The dimension below eaves, balconies and car ports can be reduced to 25mm, as long as the flue terminal is extended to clear any overhang. External flue joints must be sealed with suitable silicon sealant.
17. Flue clearance must be at least 300mm from the ground. Terminal guards must be fitted if the flue is less than 2 metres from the ground or if a person could come into contact with the flue terminal.
18. 600mm distance to a surface facing a terminal, unless it will cause a nuisance. BS 5440: Part 1 recommends that care is taken when siting terminals in relation to surfaces facing a terminal.

Note:

- ▶ Installations in car ports are not recommended.
- ▶ The flue cannot be lower than 1,000mm from the top of a light well due to the build up of combustion products.
- ▶ Dimensions from a flue terminal to a fanned air inlet to be determined by the ventilation equipment manufacturer.

3.10 Plume management terminal positions

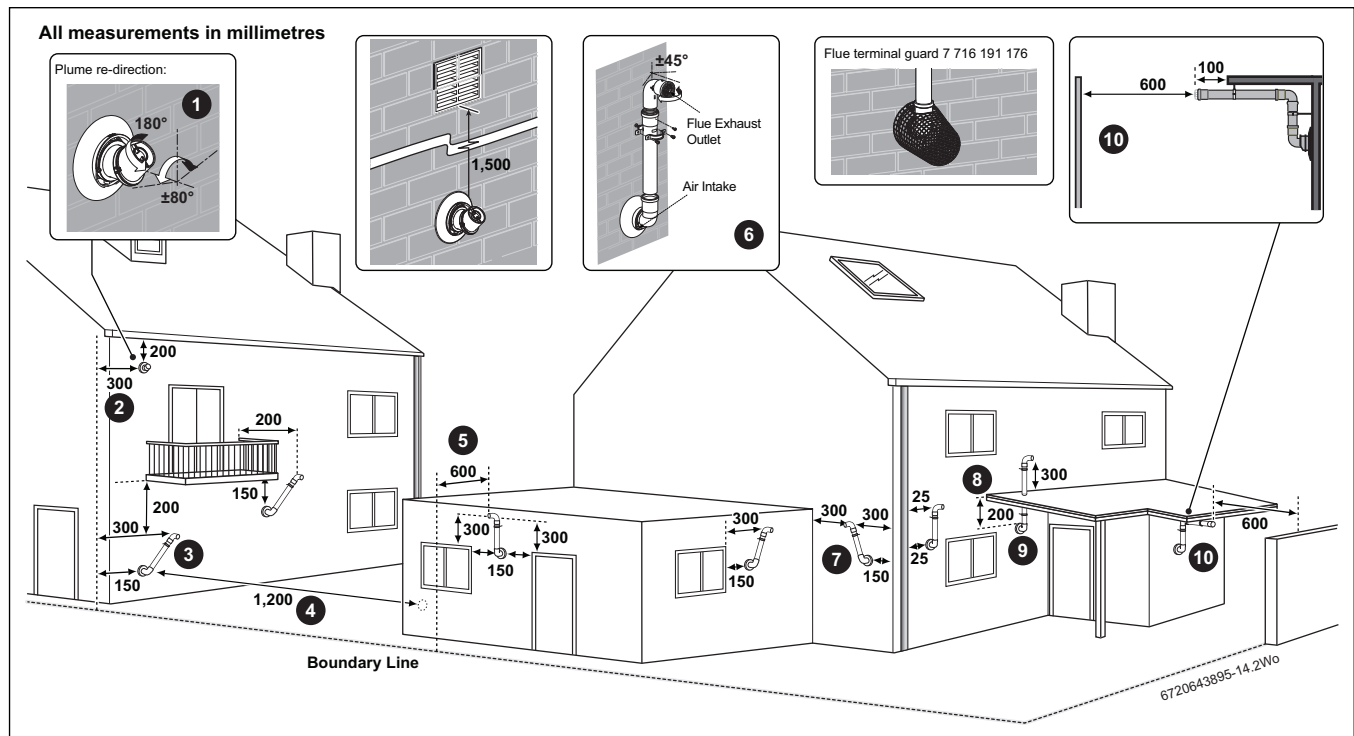

Fig. 23 Plume terminal positions

NOTICE:

- ▶ All measurements are the minimum clearances required.
- ▶ The minimum length plume management length is 500mm to a maximum of 4500mm, this includes two 90° bends. Refer to section 3.8 and table 7 for further information on internal flue lengths.
- ▶ Subsequent 45° bends = 750mm and 90° = 1500mm.
- ▶ For each metre (1000mm) of plume management length the internal flue length is reduced by 700mm.
- ▶ Refer to previous page for all concentric flue terminal positions unless the flue position is specified on the figure above "Plume terminal positions".
- ▶ Terminals must be positioned so to avoid combustion products entering the building.
- ▶ Support the flue at approximately one metre intervals and at a change of direction, use suitable brackets and fittings.

Key to illustration

1. This feature allows some basic plume re-direction options on a standard telescopic horizontal flue terminal.
300mm minimum clearances to an opening e.g. window.
However the minimum clearances to an opening in the direction that the plume management is facing, must be increased to 1,500mm.
Where the flue is less than 150mm to a drainpipe and plume re-direction is used the deflector should not be directed towards the drainpipe.
2. 300mm adjacent to a boundary line.
3. Plume Management kit air intake can be reduced to 150mm providing the flue exhaust outlet is no less than 300mm adjacent to a boundary line.
4. 1,200mm between terminals facing each other.
5. 600mm distance to a boundary line, unless it will cause a nuisance. BS 5440: Part 1 recommends that care is taken when siting terminal in relation to boundary lines.
6. Using a Plume Management kit the air intake measurement can be reduced to 150mm providing the flue exhaust outlet has a 300mm clearance.
Plume kits running horizontally must have a 10° fall back to the boiler for proper disposal of condensate.
For details on specific lengths see relevant boiler Technical & Specification information.

7. Internal/external corners. The air intake clearance can be reduced to 150mm providing the flue exhaust outlet has a 300mm clearance.
8. Clearances no less than 200mm from the lowest point of the balcony or overhang.
9. 1,200mm from an opening in a car port on the same wall e.g. door or window leading into the dwelling.
10. 600mm distance to a surface facing a terminal, unless it will cause a nuisance. BS 5440: Part 1 recommends that care is taken when siting terminals in relation to surfaces facing a terminal.



Note:

- ▶ Installations in car ports are not recommended.
- ▶ The flue cannot be lower than 1,000mm from the top of a light well due to the build up of combustion products.
- ▶ Dimensions from a flue terminal to a fanned air inlet to be determined by the ventilation equipment manufacturer.

4 INSTALLATION



NOTICE: All the previous Pre-Installation sections must be read and requirements met before starting boiler or flue installation.

4.1 Unpacking wall frame and ancillary items

LIFTING AND CARRYING PRECAUTIONS:



WARNING:

- ▶ Lift only a manageable weight, or ask for help.
- ▶ When lifting the boiler, bend the knees, and keep the back straight and feet apart.
- ▶ Do not lift and twist at the same time.
- ▶ Lift and carry the boiler close to the body.
- ▶ Wear protective clothing and gloves to protect from any sharp edges.

IMPORTANT HANDLING INSTRUCTIONS

- It is advised that two people are used to carry the carton from the van to the point of delivery.
 - Once the carton has been delivered, the top of the carton is opened. If a sharp implement is used make sure the carton is not pierced and that the implement is used in such a way so that it may not cause personal injury. All sharp objects must be covered or the blade retracted after use and put away in a safe place.
1. The upper carton cover [14] and support [13] are now removed with the components (bottom panel [12], pre-plumbing manifold with water and gas connections [11], hardware packs x2 [4] and [5], documentation set [6], hanging bracket [3]).
 2. Remove the flow [7] and return pipes [8] and [9].
 3. The boiler wall mounting plate [2] can now be pulled out.

Additional requirements for roof space installation:

- The boiler should be first unpacked before ascending ladder to loft space.
- Two sets of steps should be used.
- Two people should share the lifting of the boiler up to the loft hatch, where the boiler is entered into the loft space tilted and slid on its back into the loft.

Once the appliance is removed from its packaging check the contents against the packing list.



NOTICE: Before installing appliance ensure system has been cleaned as explained on page 8.

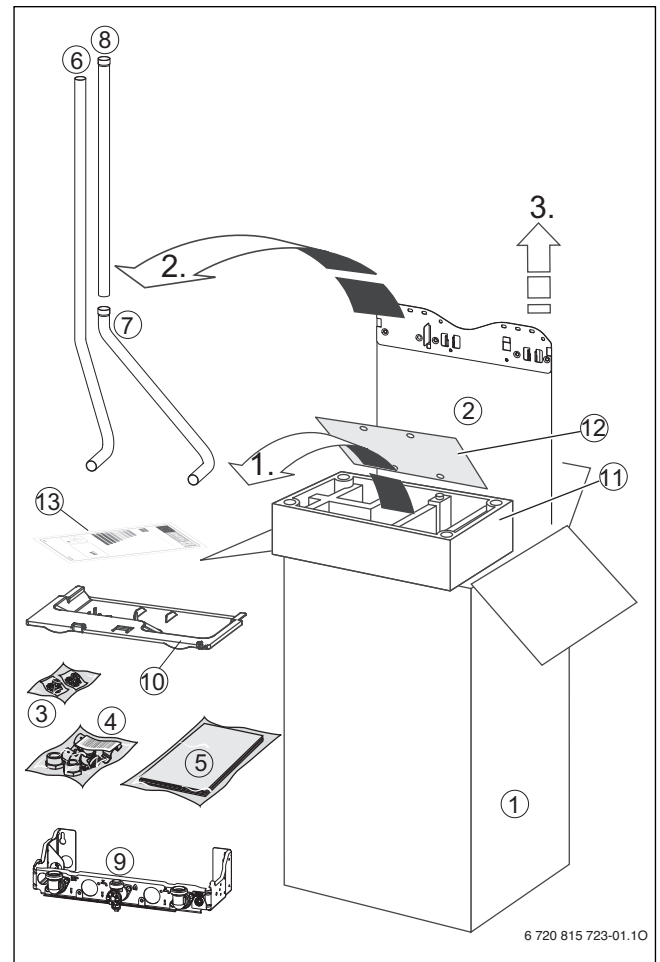



Fig. 24 Contents

- [1] Carton
- [2] Wall mounting plate
- [3] Hardware pack 1
- [4] Hardware pack 2
- [5] Literature pack
- [6] Flow pipe
- [7] Return pipe 1
- [8] Return pipe 2
- [9] Pre-plumbing manifold with water and gas connections
- [10] Bottom panel
- [11] Upper carton support (polystyrene)
- [12] Carton cover
- [13] ErP energy label

4.2 Wall mounting plate and flue opening

 **CAUTION:** Ensure there are no pipes, electric cables, damp proof courses or other hazards before drilling.

SAFETY:

All relevant safety precautions must be undertaken. Protective clothing, foot wear, gloves and safety goggles must be worn as appropriate.

FIXING THE POSITION OF THE WALL MOUNTING PLATE:

- Fig. 25 shows the relative positions of the flue and the fixing of the wall mounting plate including hanging bracket and pre-plumbing manifold.

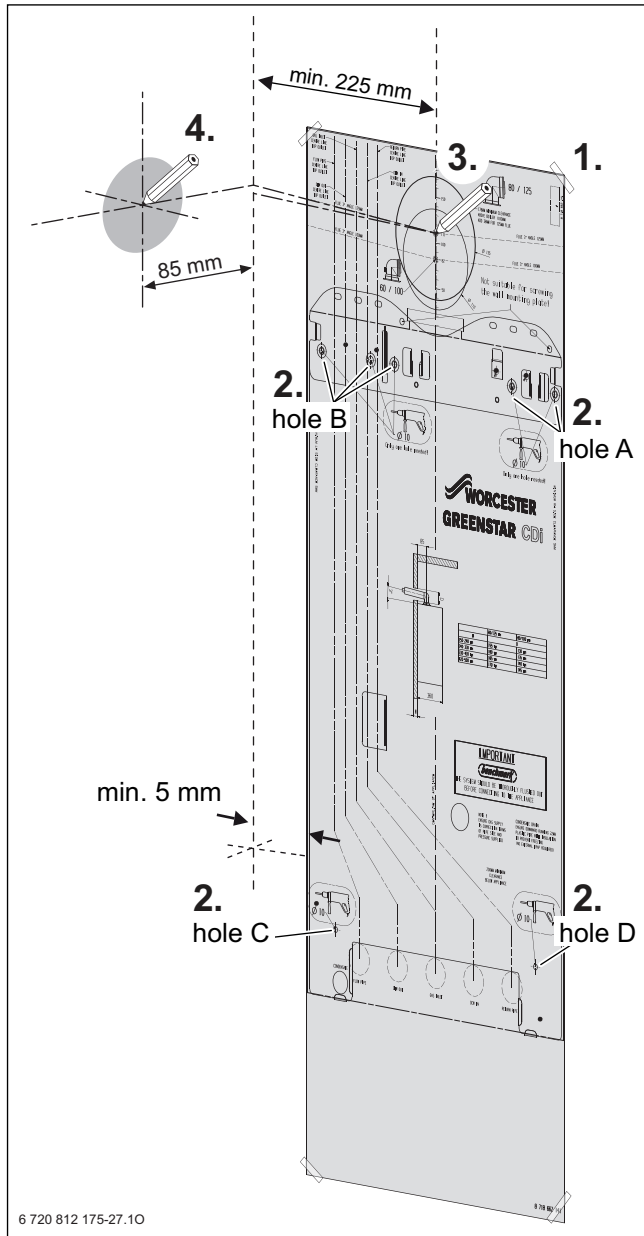

Fig. 25 Mounting template

- ▶ Fix the wall mounting template, supplied with the literature pack, to the wall.
- ▶ Drill holes for wall mounting plate and pre-plumbing manifold:
 - at least one of the holes A,
 - at least one of the holes B (preferably use left hole),
 - hole C,
 - hole D.
- ▶ If required: make a hole in wall for the flue pipe.

FLUE OUTLET

- ▶ Follow the Fig. 25 to mark the centre of the flue for rear outlet (3) or for side outlet (4).
- ▶ For the 60/100mm Ø flue make a 125 mm diameter hole through the wall using a core drill or similar.
For flues using an optional weather collar, fitted from inside the building make a 150 mm Ø hole.
- ▶ Clear away any debris.
- ▶ Drill the hole, preferably using a core drill.
- ▶ Remove the mounting template.
- ▶ Place the wall mounting plate with hanging bracket against the wall in the desired position.
- ▶ Secure wall mounting plate with four screws (supplied with the boiler). Do not fully fasten the lower two screws.
- ▶ Mount the pre-plumbing manifold on the two lower screws and secure the screws.

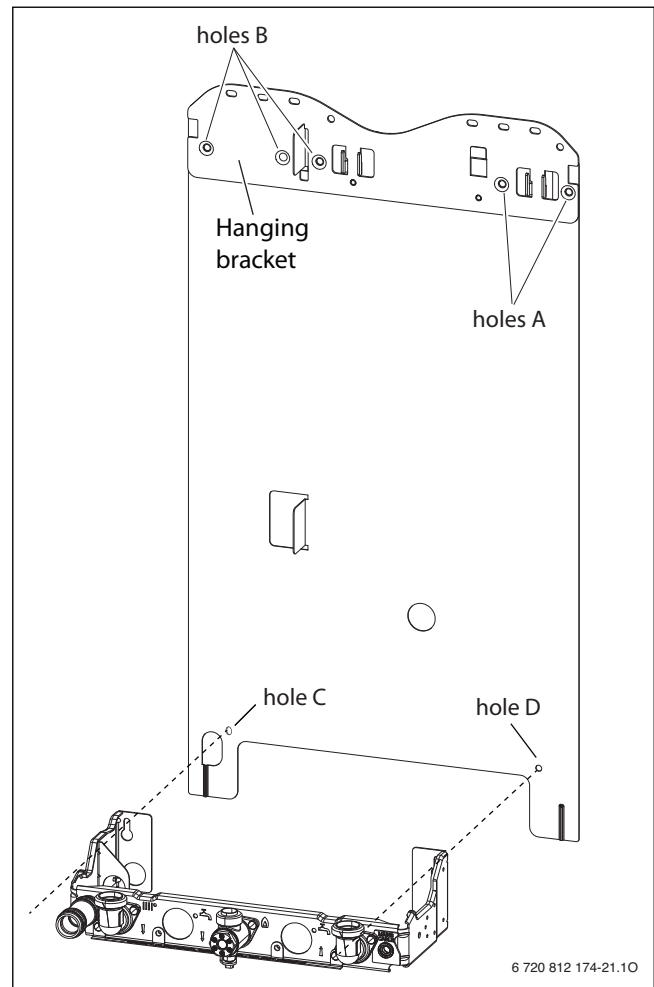

Fig. 26 Wall mounting plate and pre-plumbing manifold

4.3 UNPACKING THE APPLIANCE

1. With the wall frame and ancillary items removed, lay the carton (A) on its back.
2. Open the carton bottom flaps and fold under boiler. Do not remove the packaging base.
3. Stand carton (A) with boiler upright on the packaging base (B).
4. Remove outer carton (A) and place safely away from the working area.
5. Remove the protective wrapping (C).
6. Lie the boiler on its back.
7. Remove the packaging base (B) and place safely away from the working area.

REMOVING OUTER CASE

8. Loosen but do not remove the two screws (E) securing boiler casing at the bottom of the appliance.
9. Release the clip (F) on top of the boiler and pull the case upwards.
10. Remove the outer case.
11. Remove the protective packaging (G) from the electrode assembly.

A - Outer carton

B - Packaging base

C - Protective wrapping

D - Appliance outer case

E - Screws

F - Clip

G - Protective packaging (electrodes)

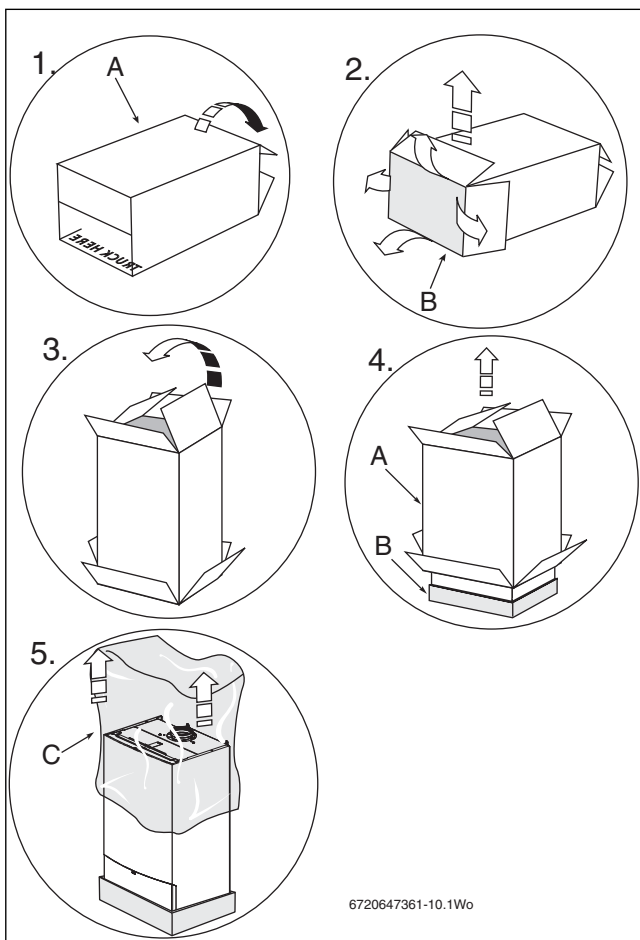

Fig. 27

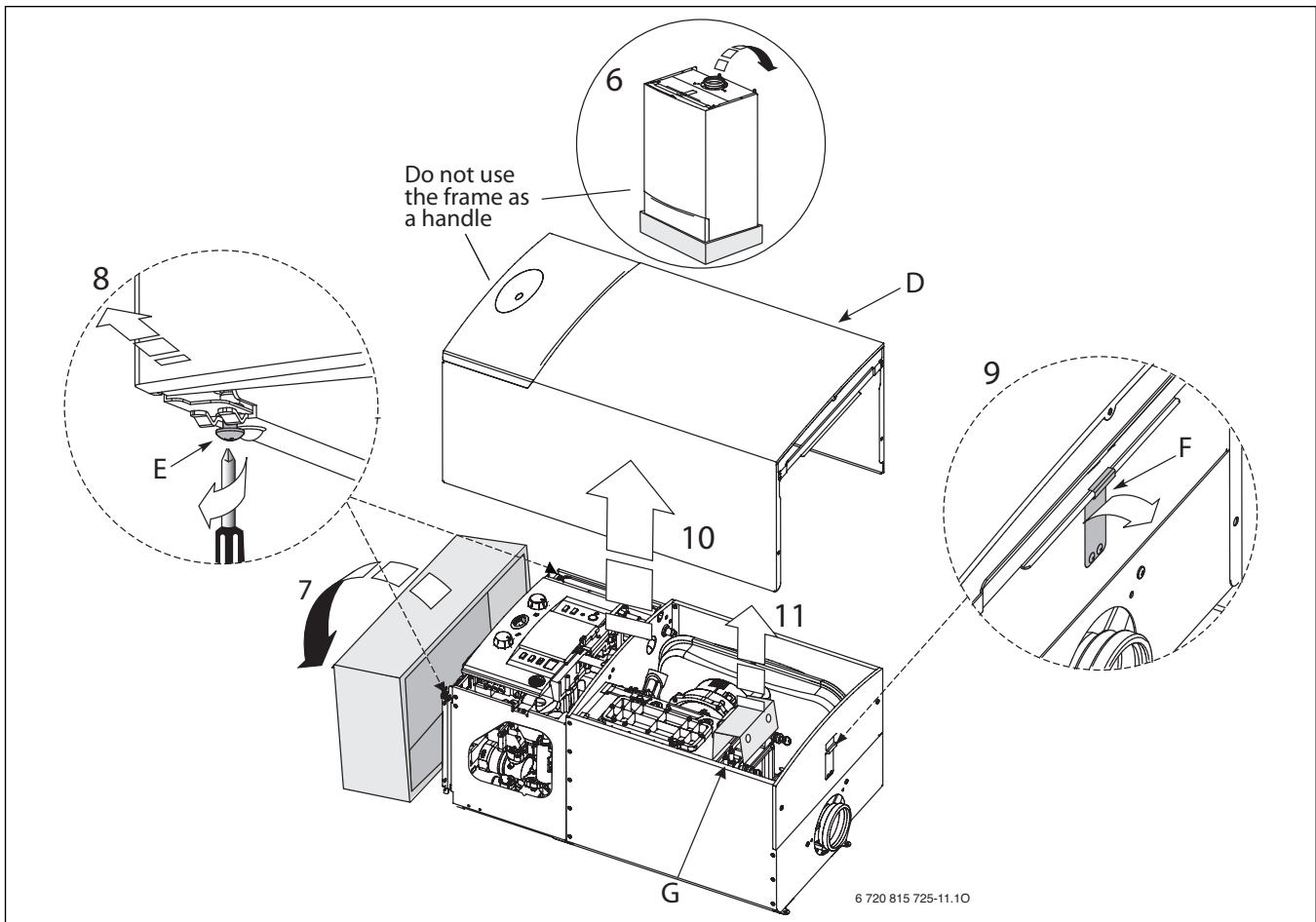

Fig. 28

4.4 Fitting the appliance boiler connections

CAUTION: Isolate the mains gas supply before starting any work and observe all relevant safety precautions.

GAS AND WATER CONNECTIONS:

• If there is greater than 600mm clearance below the appliance it is possible to fit the flow and return pipes, supplied, with the boiler installed on the wall. If clearance is less than 600 mm below the appliance it may be necessary to fit the flow and return pipes before hanging the appliance.

▶ System pipes may be run vertically up behind the boiler or below it. See Plumbing Manifold Section on page 14.

i If pipes require reducing in length this is best done before they are fitted to the boiler.

- A - Flow (22mm)
- C - Return (22mm)
- B - Gas inlet (22mm)

1. Fit the sealing washers before hanging boiler.
- ▶ Remove the plastic strip from connections on boiler.

i The accessibility to the pre-plumbing manifold can be improved by removing the condensate trap.

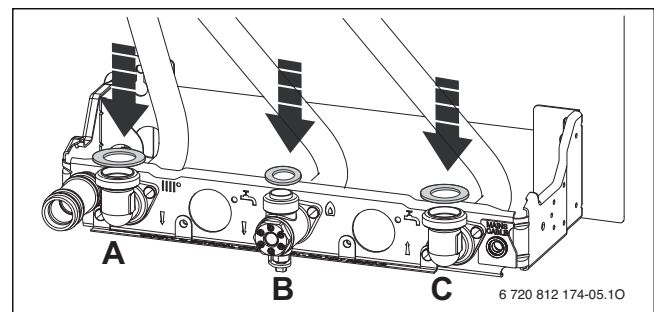

Fig. 29 Fit washers

2. Hang the boiler on to the hanging bracket. The lugs pass through the rectangular holes in the boiler back panel. Take care not to disturb the washers on the connections.

i ▶ Lifting should be performed by 2 people, observing all precautions for safe lifting of heavy objects.
▶ Do not lift by the top case panel. There are two handling holes in the inner casing left and right in the lower section of the appliance.

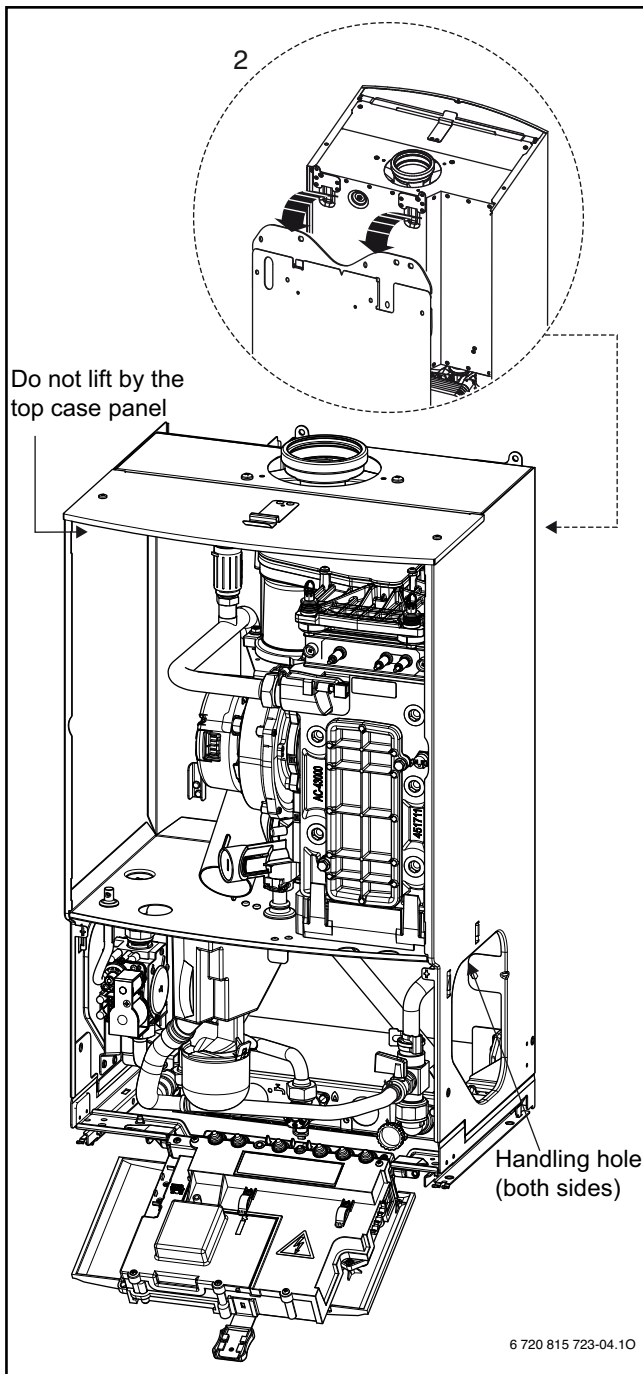

Fig. 30 Hang the boiler

3. Lower the control panel into the service position by releasing the white catch on the retaining bracket.
4. Make connections to the heating system.
 - ▶ Connect the gas supply to the boiler gas cock 22mm compression fitting.

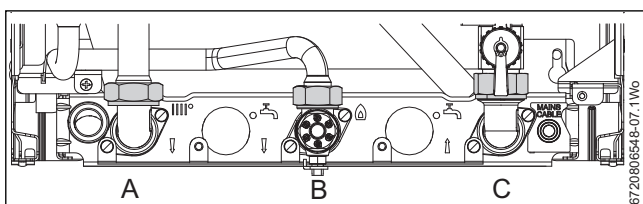

Fig. 31 Connections

4.5 Flue installation

HORIZONTAL FLUE

(60/100mm diameter)

For vertical flues and 80/125mm horizontal flues, please refer to separate Flue Kit instructions.



Apply silicone lubricant to the sealing surfaces of the flue components to ease assembly of flue components.

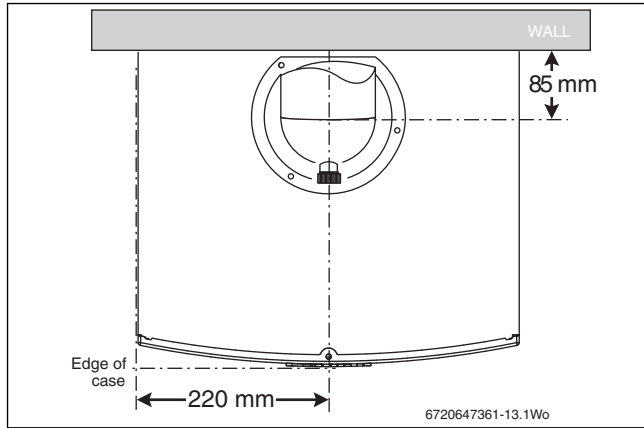

Fig. 32

4.5.1 Ø60/100mm Telescopic flue kit:

Standard telescopic flue 350 - 570mm,
part Number: 7 716 191 082

Longer Telescopic flue 570 - 790mm,
part number: 7 716 191 171

The standard telescopic flue terminal length can be reduced or extended to within 350 to 570 mm or 570 to 790mm for the longer telescopic flue without cutting and can be used with Condensfit II flue extension components.

The terminal end of the standard telescopic flue can be further reduced to 130mm, if necessary, refer to the Flue Instruction manual supplied. The plume deflector can be adjusted to redirect the flue discharge allowing some plume management control, alternatively, a complete plume management system can be fitted to the flue terminal. Refer to the Flue Instruction manual supplied with the flue kit.

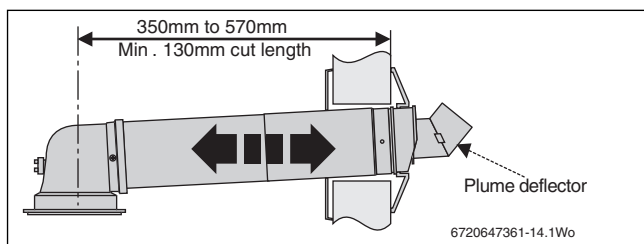

Fig. 33 Telescopic flue

4.5.2 Ø60mm Plume management kit:

Part Number: 7-716-191-086

The plume management system connects to the terminal outlet of the Telescopic flue and must not be used with the flue terminal of the Standard Flue Kit.

The plume management system can be reduced by cutting (min 500mm) and can be used with plume management extension components.

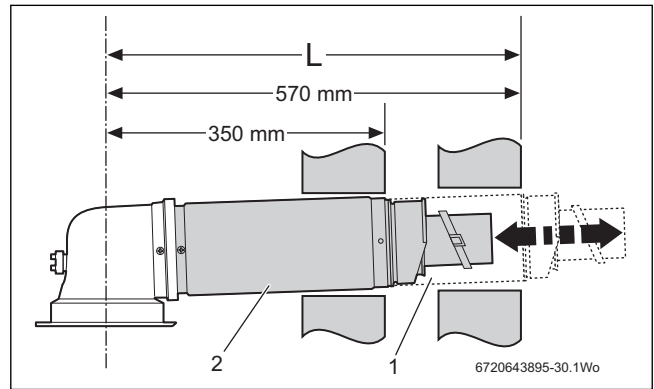

Fig. 34

Ø60mm PLUME MANAGEMENT KIT (7-716-191-086) replaces the plume deflector in the Ø60/100mm telescopic flue terminal.

4.5.3 ADJUSTING THE STANDARD TERMINAL LENGTH:

1. Extend tube (1) by withdrawing from tube (2) to achieve the flue length required, 350- 570mm for the standard telescopic flue or 570 to 790mm for the longer telescopic flue. Secure with screw provided and seal joint with the aluminium tape supplied.

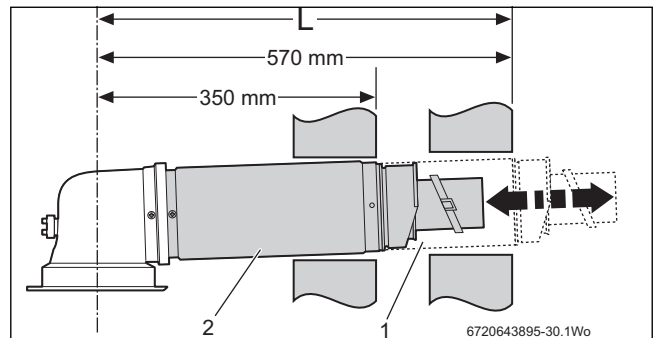

Fig. 35 Standard telescopic flue

Reducing the standard terminal length:

2. Remove securing screws (3) to detach the terminal assembly from the turret. Slide terminal section (2) from the terminal assembly and discard. To use terminal (1) without cutting remove the location lug (4) on the inner flue tube (5) and remove any burrs. To reduce the terminal length further:
3. Mark the length required for the terminal (6) as shown (min 130mm) and cut square, taking care not to damage the tubes. Remove any burrs and chamfer the outer edge of the tubes to assist ease of connection and prevent seal damage.



The aluminium tape is not required when reducing the terminal.

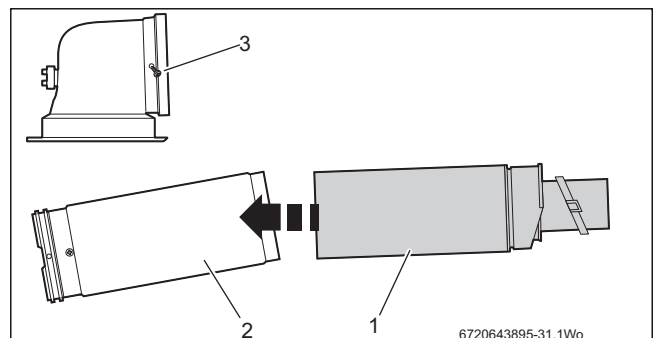

Fig. 36 Reducing the standard terminal

4.5.4 Installing the standard flue

1. Set the flue length to the distance required, secure with screw and seal joint with the aluminium tape supplied. Slide the inner wall seal (1) onto the terminal (2) as shown. If fitting from inside the building; slide the outer wall seal (3) onto the terminal (2) as shown.

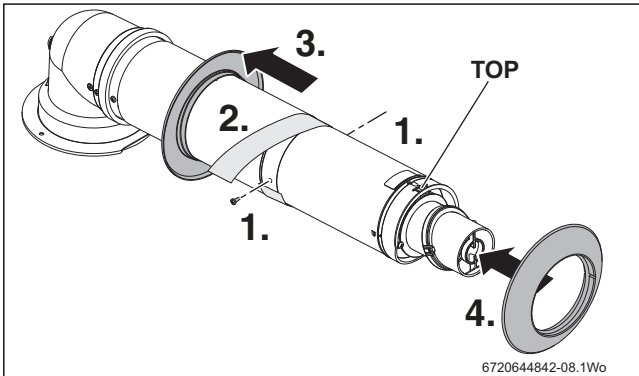

Fig. 37 Telescopic flue

2. Remove the three screws (4, 8) around the flue outlet (6) on the boiler. See screw pack in boiler. Check the boiler flue seal is correctly seated. Apply silicone grease to the boiler flue seal.
3. Position terminal (2) through the flue opening in the wall to the outside of the building by the distance shown. The flue terminal MUST be fitted with the 'TOP' uppermost to allow the correct fit and use of the plume management system.
4. Align the flue turret (5) to the boiler flue outlet (6) with flat (7) facing to the rear of the boiler. Push the flue turret (5) straight down into the boiler flue outlet (6). For ease of assembly, locate screw (8) first and then fit screws (4) to secure flue turret (5). If fitting from the outside of the building; slide the outer wall seal (3) onto the terminal (2) as shown.

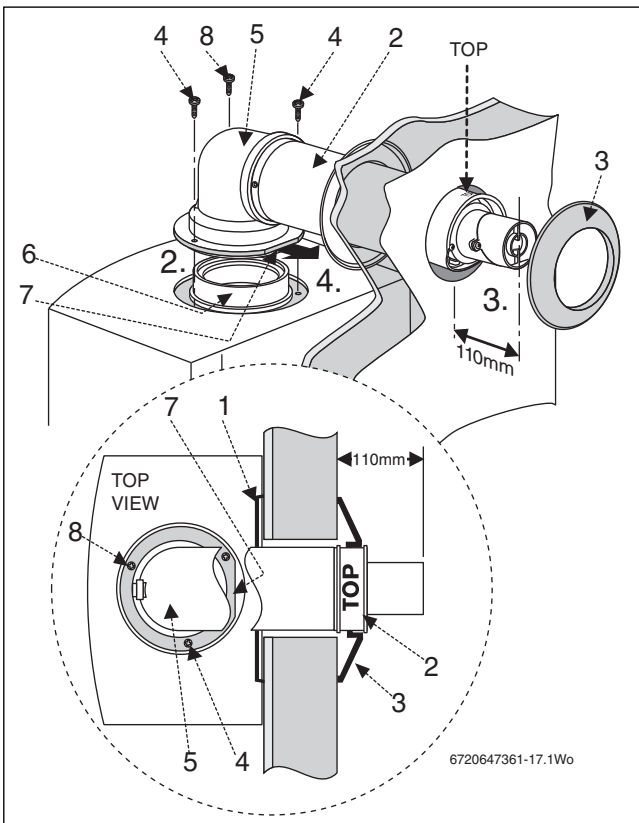



Fig. 38 Fitting the flue

4.5.5 Flue terminal plume re-direction:

The flue discharge can be re-directed allowing some plume redirection control, alternatively, a complete plume management system can be fitted to the flue terminal.

RE-DIRECTING THE FLUE DISCHARGE

1. Using a suitable tool, release the clips (1 & 2) the terminal end and rotate through 180°.

 **NOTICE:** DO NOT rotate the complete terminal assembly.

1. Refit to the terminal, ensuring that the clips (1 & 2) are engaged and secure.
2. Loosen screws (3) and rotate the entire outlet assembly to redirect the plume. Tighten screws (3) to secure in the required position.

 The flue terminal outlet has built-in stops to limit rotation for horizontal flues to allow condensate to run back into the boiler for safe disposal. Do not attempt to force beyond the limit stops.

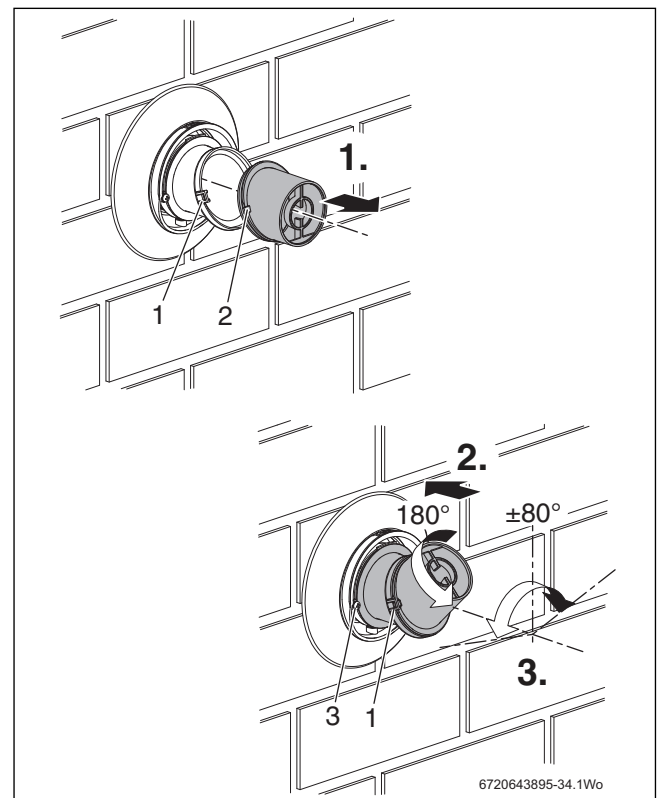



Fig. 39 Plume redirection

 **NOTICE:** Outlet position

- ▶ The flue terminal outlet position must follow those stated in the relevant appliance instruction manual. When redirecting the flue discharge the outlet terminal must be at least 1500mm from any opening in the direction of the discharge to prevent combustion products from entering the building.

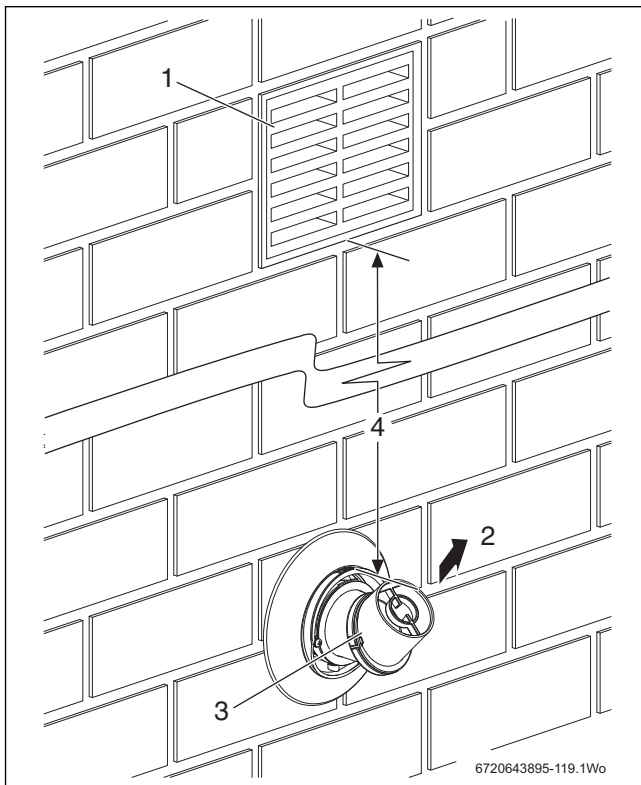

Fig. 40 Plume distance to opening

| | |
|---|------------------------------------------------|
| 1 | Opening in building |
| 2 | Flue discharge |
| 3 | Plume deflector |
| 4 | Minimum 1500mm from an opening in the building |

Table 19 Key to figure 40

4.6 CONDENSATE CONNECTION

Never terminate or discharge into any open source, including; sink, bath, shower, bidet, toilet etc.

i Any external condensate pipe work of excessive runs should be protected with weather resistant insulation to help prevent freezing.

- Ensure that the condensate drain is 22 mm diameter plastic pipe. It must fall at least 50 mm per metre towards the outlet.
- An adaptor (A) in 22 mm pipe is contained in the fitting pack.

4.7 ELECTRICAL



CAUTION: Isolate the mains gas supply before starting any work and observe all relevant safety precautions.

Danger of short circuit: When connecting the cables ensure that no cable strands fall into the Heatronic.



Mains supply to the boiler must be through a fused double pole isolator situated adjacent to the appliance. The isolator must have a contact separation of 3 mm minimum in all poles.

Access to electrical connections:

- ▶ Remove boiler casing to access control panel.
- 1. Press in the centre of the white plastic clip securing the control panel, slide down to release and lower into the service position.
- 2. Unscrew the three screws (B) on the back of the control panel and pull off the connections cover.
- 3. Unclip cable clamp (C).
- 4. Cut off the tapered cable entry to fit cable diameter required.
- 5. Turn cable retaining screw (D) anti-clockwise. Run cable over the main crossbar and through the cable clamp (C), ensuring there is ample cable to reach the connectors. Turn the cable clamping screw (D) clockwise to secure the cable and replace the clamp (C) into control panel.
- 6. Mains power 230 V connection (ST10) pre-mounted:
 - ▶ Separate the wires from the cable end and strip the wires back by 6mm
 - ▶ Connect the LIVE wire to the terminal (L)
 - ▶ Connect the NEUTRAL wire to the terminal (N)
 - ▶ Connect the EARTH wire to the earth connector (\perp)



Ensure that the Earth cable is longer than the others so that it pulls out last if the mains cable is snagged.

7. External controls wiring box (ST10):

- ▶ Remove the link
- ▶ Connect the wiring box LIVE supply to terminal (LS)
- ▶ Connect the wiring box LIVE return to terminal (LR)
- ▶ Connect the wiring box NEUTRAL to terminal (NS)



- ▶ For a description of the wiring box see proprietary instructions.
- ▶ Refer to manufacturers instructions when connecting external parts to the wiring centre. Worcester, Bosch Group cannot be held responsible for wiring errors.

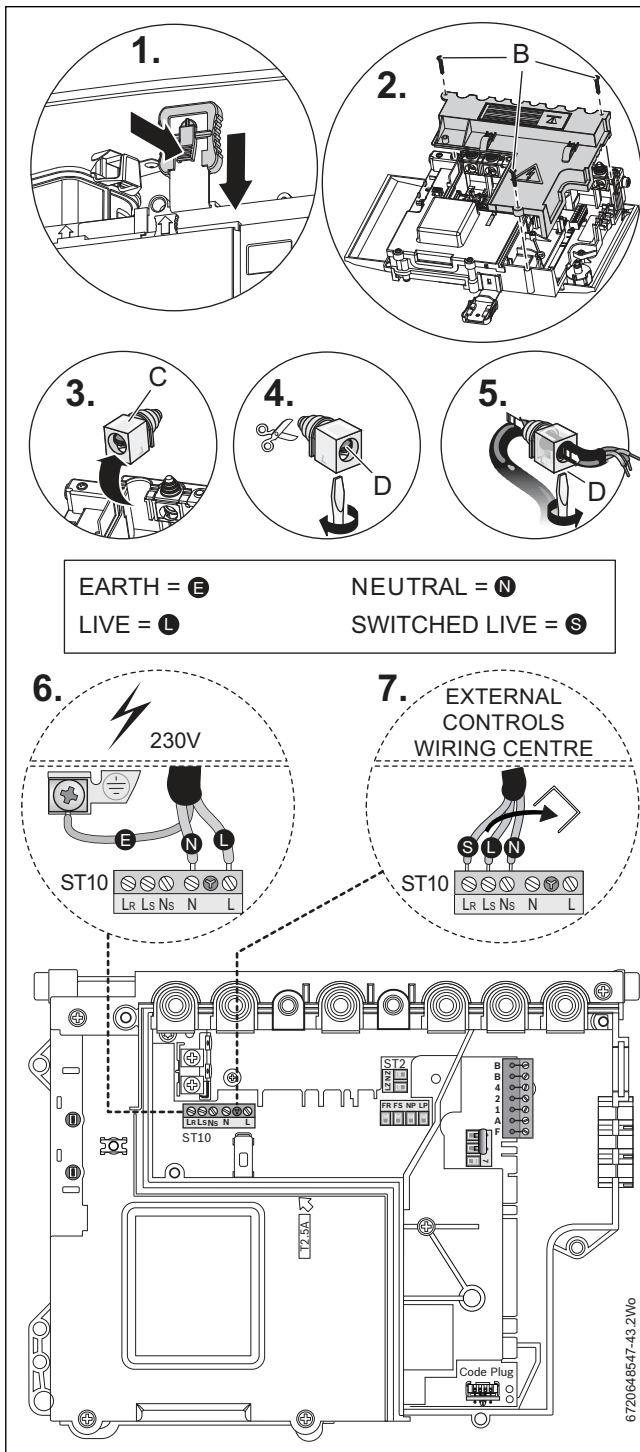

Fig. 41 Control panel access

CAUTION: Isolate the mains gas supply before starting any work and observe all relevant safety precautions.

CAUTION: Short circuit
▶ When connecting the cables ensure that no cable strands fall into the Heatronc.

i The mains supply to the boiler must be fed through a fused double pole isolator situated adjacent to the appliance.
The isolator must have a contact separation of 3 mm minimum in all poles.

8. External Pump (ST2):

- ▶ Connect NEUTRAL wire to terminal (Nz)
- ▶ Connect LIVE wire to terminal (Lz)
- ▶ Connect EARTH wire to earth bracket (E)

i The system pump must be connected to the appliance control for the pump over-run facility.

9. Refit control panel cover:

- ▶ Refit panel and secure with screws (B).
- ▶ Bring the control panel to its upper position and secure by sliding the white plastic clip up.

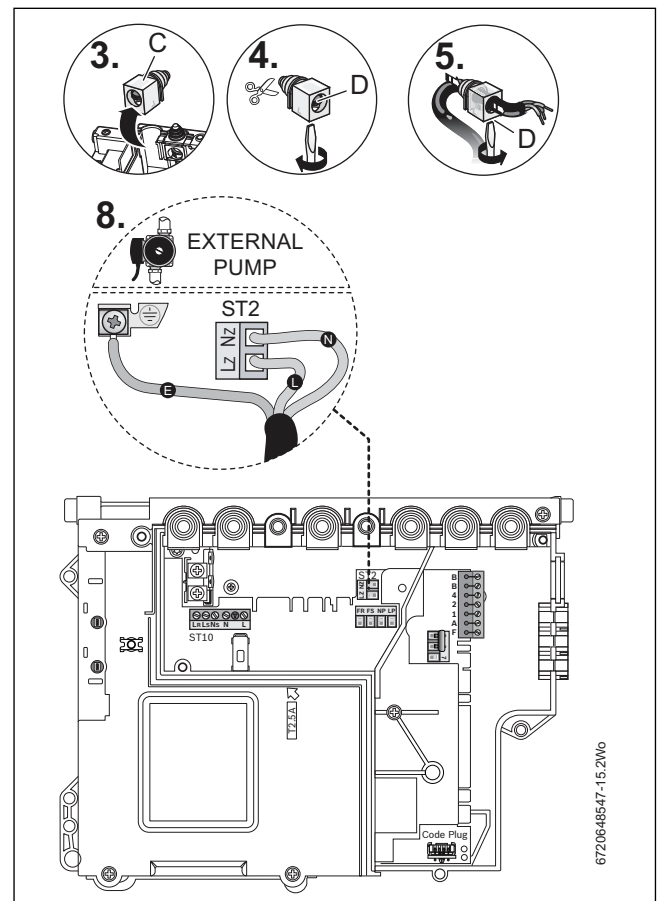

Fig. 42 Electrical connections

4.8 Position of wired components

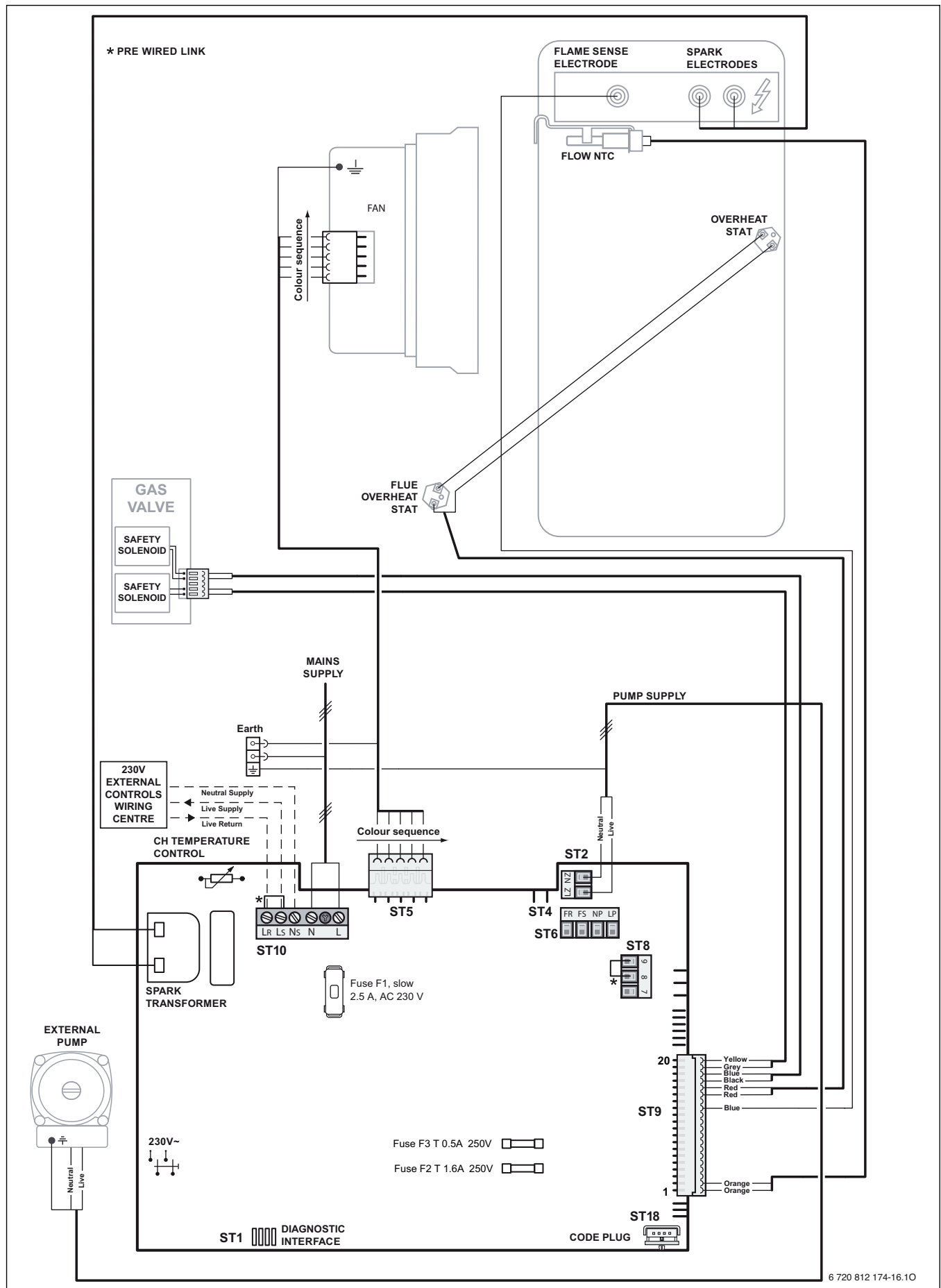

Fig. 43 Wired components

5 COMMISSIONING

5.1 Pre-commissioning checks



CAUTION: Isolate the mains gas supply before starting any work and observe all relevant safety precautions.

1. Check that the service and water pipes are connected to the correct position on the manifold.
A - CH flow (22mm)
B - CH return (22mm)
C - Gas inlet (22mm)
2. Check the gas type specified on the identification plate (F) matches that of the gas supply. Turn on the main gas supply, check the gas pipe work, connections and rectify any leaks.
3. Check that the condensate pipe has been connected to the adapter



NOTICE: If the boiler is not to be commissioned immediately then: after successfully completing all of the checks and any rectification work, close the gas and water valves, shut off the gas supply and electrically isolate the boiler.

5.2 Condensate connection

Never terminate or discharge into any open source, including; sink, bath, shower, bidet, toilet etc.



Any external condensate pipe work of excessive runs should be protected with weather resistant insulation to help prevent freezing.

- ▶ Ensure that the condensate drain is 22mm diameter plastic pipe. It must fall at least 52mm per metre towards the outlet



A 22mm adaptor pipe is contained in the fitting pack.

Refer to figure 44, condensate connection:

1. Align the installation side plastic pipework through the pre-plumbing manifold.
2. Connect the installation side plastic pipework to the end of the condensate hose.
3. Push the plastic pipework inside the condensate hose at least 25mm.

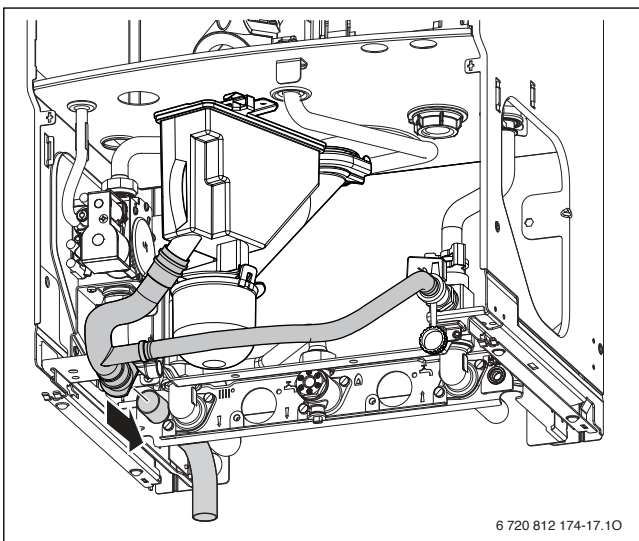

6 720 812 174-17.1O

Fig. 44 Condensate connection

5.3 Filling the system

1. Ensure all system and boiler drain points are closed.
2. For sealed systems fill the system using a WRAS approved filling loop to a pressure of 1 bar.
3. Vent all radiators and primary side of the hot water cylinder.
4. Refill the system up to 1 bar.

GAS SUPPLY

- ▶ Open gas cock on the boiler and purge the gas supply to the boiler ensuring that the room is well ventilated.
- ▶ Test gas supply for soundness as described in BS 6891.

5.4 STARTING THE APPLIANCE

 **NOTICE:** Never run the appliance when the appliance/system is empty or partially filled.

SWITCHING THE APPLIANCE ON/OFF:

1. Turn on mains power supply.
 - ▶ Turn on any external controls.
 - ▶ Set the thermostatic radiator controls to maximum temperature.
 - ▶ Set the clock/programmer to continuously ON and the room thermostat to maximum temperature.

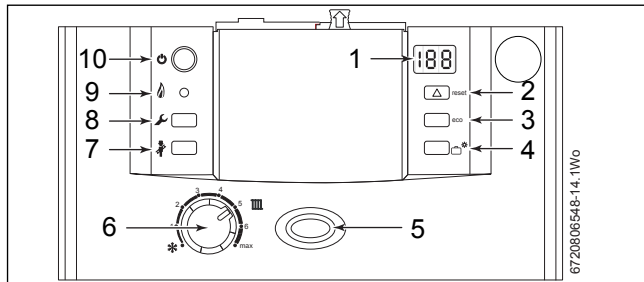



Fig. 45 Control panel

- [1] Display
- [2] Reset button
- [3] Not used
- [4] Not used
- [5] ON/OFF and fault indicator (Blue)
- [6] Central heating temperature control
- [7] Performance test button
- [8] Service button
- [9] Burner indicator (Green)
- [10] ON/OFF button

- ▶ Press button (10) and the power on indicator (5) illuminates BLUE. After a few seconds the display will show the flow temperature.
2. Turn the CH temperature control (6) to maximum. The burner on indicator (9) illuminates GREEN when the burner has lit.

 The boiler runs for 15 minutes at minimum heating output to fill the condensate trap, the display (K) alternates between “-II-” and the flow temperature. This occurs every time the mains supply has been interrupted. This could take longer than 15 minutes if high output is demanded.

3. If the boiler fails to light the BLUE power indicator (5) and reset button (2) will flash alternately. To reset press and hold the reset button (2) for 2 seconds. The boiler will be reset.

 **CAUTION:** DO NOT PRESS POWER INDICATOR (5) TO RESET BOILER.

5.5 Water treatment

 **NOTICE:** Debris from the system can damage the boiler and reduce efficiency. Failure to comply with the guidelines for the use of water treatment with the appliance will invalidate the appliance warranty.

Ensure that the system has been cleaned as on 8 of these instructions.

FLUSHING (Central Heating):

1. Switch off the boiler.
 - ▶ Open all drain cocks and drain the system while the appliance is hot.
2. Close drain cocks and add a suitable flushing agent at the correct strength for the system condition in accordance with the manufacturer’s instructions.

3. Run the boiler/system at normal operating temperature for the time stated by the manufacturer of the flushing agent.
4. Drain and thoroughly flush the system to remove the flushing agent and debris.

INHIBITOR (Central Heating):

5. Check drain cocks are closed and all radiator valves are open before adding a suitable* inhibitor (or combined inhibitor/anti-freeze if the system is exposed to freezing conditions) to the heating system water in accordance with the manufacturers instructions.
6. Fill via a WRAS approved filling loop to between 1 and 2 bar.
7. Vent all radiators; retighten vents when complete.
8. Vent the primary side of the hot water tank.
 - ▶ For sealed systems re-pressurise if necessary.
 - ▶ Set all controls to maximum.
 - ▶ Record the date when the inhibitor was added to the system on the guarantee card.



- ▶ The concentration level of inhibitor in the system should be checked every 12 months or sooner if system content is lost.
- ▶ The addition of sealing agents to the system water is not recommended as this can cause problems with deposits left in the heat exchanger.

*** compatible with aluminium. The pH value of the system water must be less than 8 or the appliance guarantee will be invalidated.**

Water treatment products

Suitable water treatment products can be obtain from the following manufacturers:

| | |
|----------|--------------------------------------------------------------------------------------------|
| FERNOX | 0870 601 5000 / www.fernox.com |
| SENTINEL | 0800 389 4670 / www.sentinel-solutions.net |

5.6 Commissioning

CHECKING GAS INLET PRESSURE:

The inlet pressure to the appliance must be checked using the following procedure:

SETTING THE BOILER TO MAXIMUM:

1. Press performance test button (7) for ten seconds and set temperature control (6) to maximum.
 - The performance test button (7) will illuminate continually.

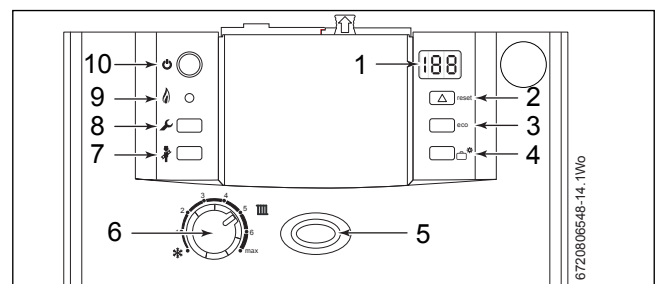

Fig. 46 Control panel

- [1] Display
- [2] Reset button
- [3] Not used
- [4] Not used
- [5] ON/OFF and fault indicator (Blue)
- [6] Central heating temperature control
- [7] Performance test button
- [8] Service button
- [9] Burner indicator (Green)
- [10] ON/OFF button

5.7 CO AND COMBUSTION CHECKS

The following combustion and flue integrity checks will be mandatory from April 2014 and these values must be recorded on the Benchmark check list, at the back of this manual.

Once the gas rate and pressure have been confirmed as acceptable, then the CO and combustion checks can be undertaken.

The flow chart is given for guidance; the details of the checks are given in the following sections:

- Checking flue integrity, refer to section 6.1.2, page 34
- Setting the air/gas ratio, refer to section 6.2, page 38



NOTICE: BEFORE CO AND COMBUSTION CHECKS:

- ▶ Refer to section 5.6.1 and 5.6.2 to verify gas type, gas inlet pressure, and gas rate. Visually check the integrity of the whole flue system and confirm that all the components are correctly assembled, fixed and supported.
- ▶ The flue gas analyser must be the correct type as specified in BS 7967. Before use the analyser must have been calibrated as specified by the manufacturer. The installer must be competent in the use of the analyser. Check and zero the analyser in fresh air as specified by the manufacturer.
- ▶ The air/gas ratio valve is factory set and must not be adjusted during commissioning unless this action is recommended following contact with the Worcester, Bosch Group help line 0330 123 3366.

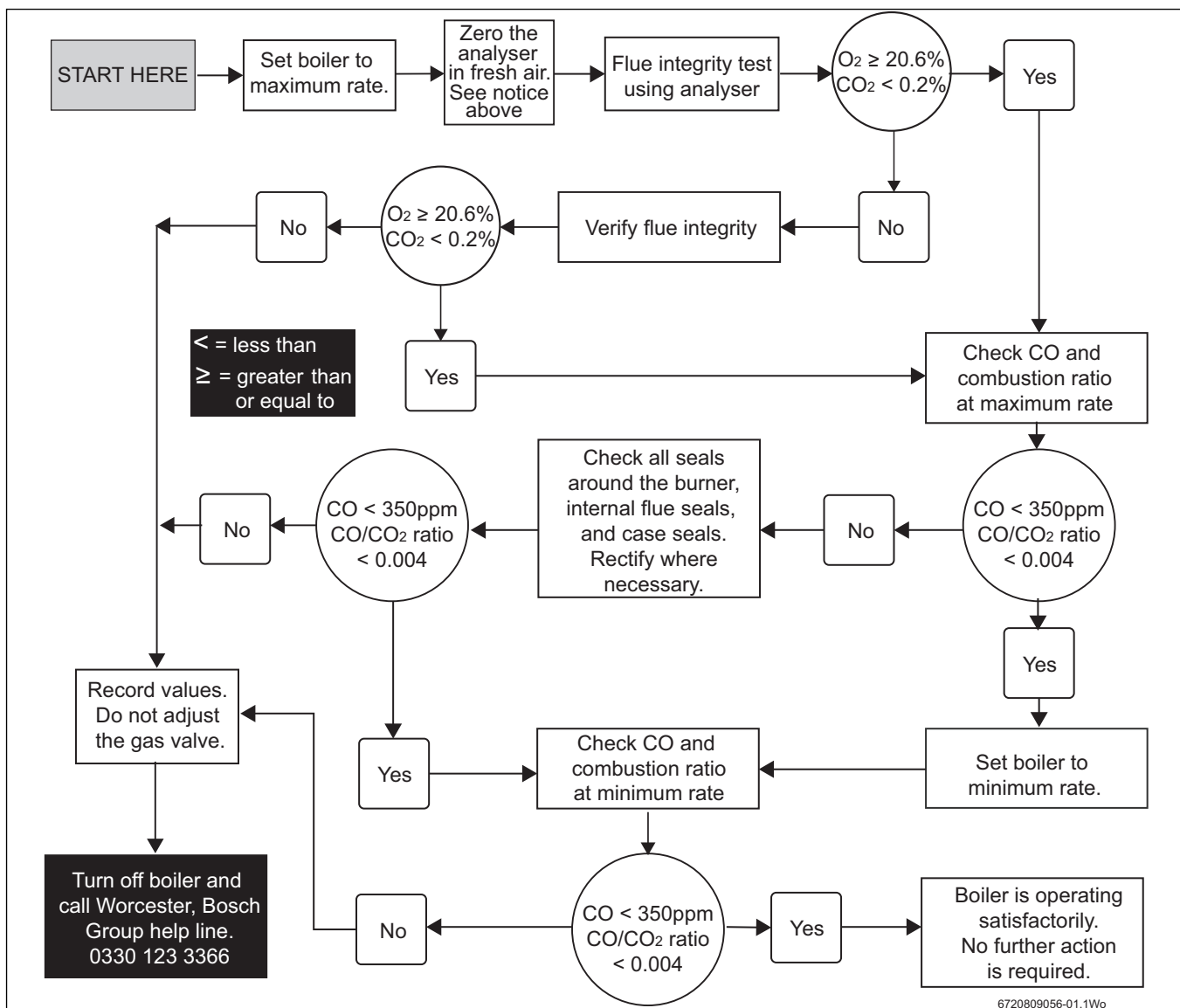

Fig. 50 Combustion check flow chart

5.8 Finishing commissioning

The boiler has been factory set, so there should be no need to adjust combustion settings.

REPLACE OUTER CASING:

1. Replace outer casing making sure that the securing points are properly located.
 - ▶ Press the clip (A) downwards to secure casing on top.
 - ▶ Retighten bottom two screws (B).

INSTALLING BOTTOM PANEL:

2. The bottom panel slides onto two ledges (C) either side of the boiler frame.
 - ▶ Hold the panel up against the underside of the boiler and slide towards the rear until it is fully engaged.

HANDOVER:

- ▶ Complete the Benchmark check list.
- ▶ Open the fascia cover by pulling the centre top of the cover (D).
- ▶ Set up the controls and show the user how to operate all the controls shown in the User Guide.
- ▶ Place the user guide into the tray (E) on the inside of the fascia cover.
- ▶ If the appliance is unused and exposed to freezing conditions; shut off all the mains supplies and drain the system and boiler.

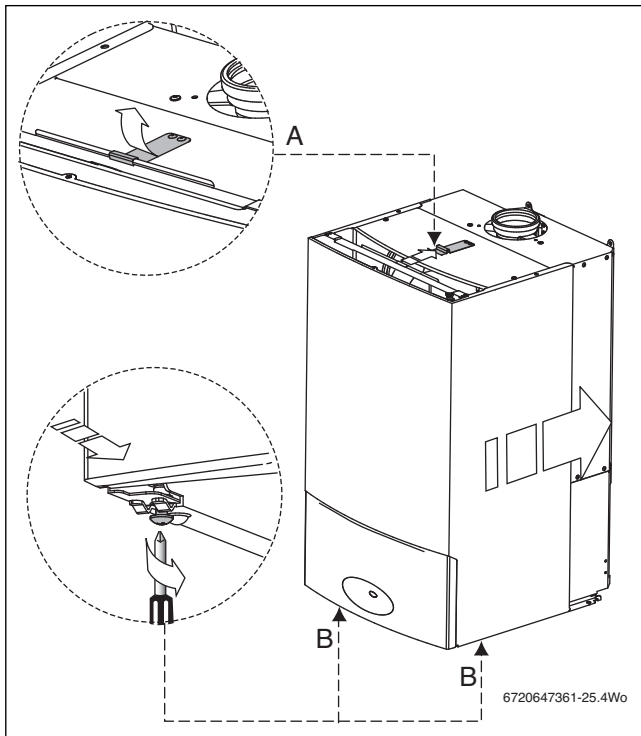

Fig. 51 Fitting outer case

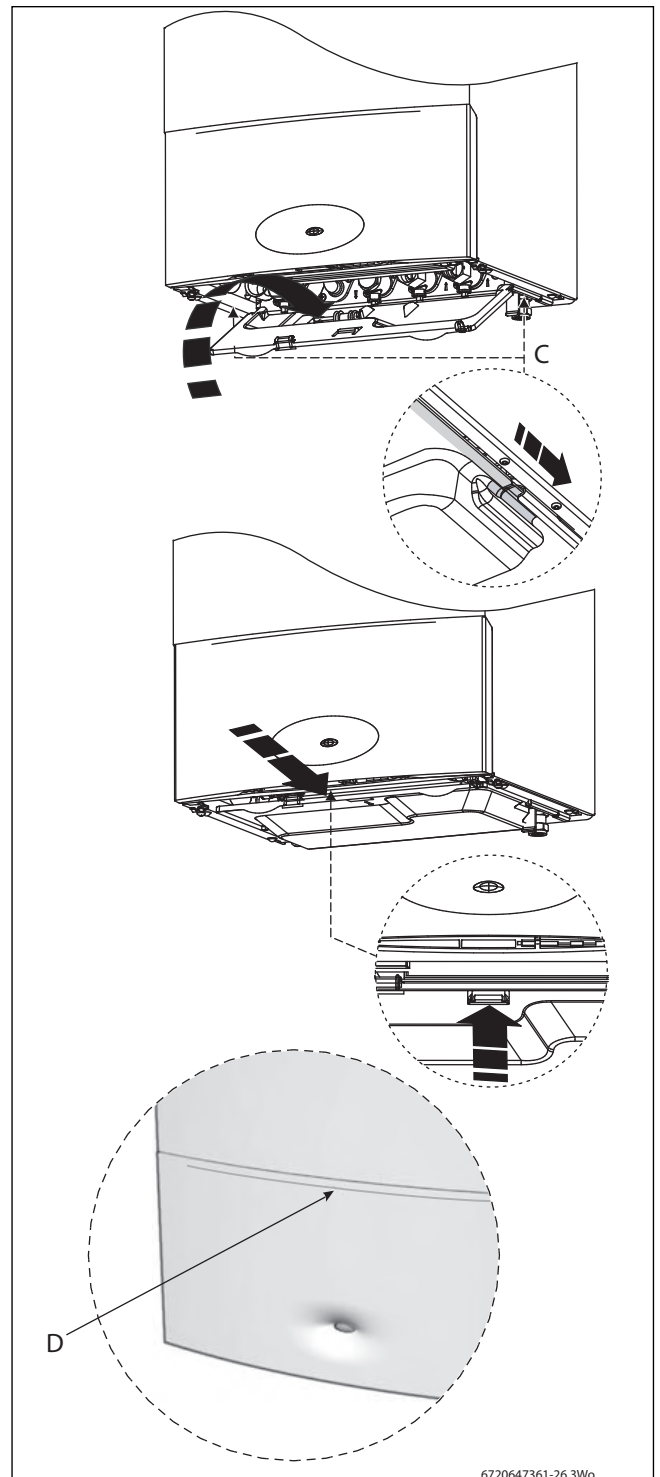

Fig. 52 Fitting bottom panel

6 SERVICING AND SPARES



CAUTION: Isolate the mains gas supply before starting any work and observe all relevant safety precautions.



NOTICE: After replacement of any components always check for gas tightness where relevant and carry out functional checks as described in commissioning. Any O-rings or gaskets that are disturbed during servicing must be replaced.

6.1 Inspection and spares



NOTICE: Any service work must be carried out by a competent registered engineer such as British Gas or Gas Safe.



NOTICE: CO/CO₂ Analyser
▶ Service work must NOT be attempted if a calibrated CO/CO₂ Analyser is NOT available.

- To ensure the continued efficient operation of the appliance it must be checked at regular intervals.
- The frequency of servicing will depend upon the particular installation conditions and usage. However, an annual service is recommended.
- The extent of the service required by the appliance is determined by the operating condition of the appliance when tested by **fully qualified engineers**.

6.1.1 Inspection

1. Check that the terminal and the terminal guard, if fitted, are clear and undamaged.
 2. If the appliance is in a compartment or cupboard check that the specified service space around the appliance is clear.
 3. Check all the joints and connections in the system and remake any that show signs of leakage. Refill and re-pressurise if applicable as described in Commissioning.
- ▶ Operate the appliance and take note of any irregularities. Call up the last fault stored by the Bosch Heatronic, Service Function **.0**. Refer to Fault Finding for rectification procedures.

6.1.2 Checking flue integrity

The integrity of the flue system and performance of the boiler can be checked via the flue turret sample points.

| | |
|------------------------|---|
| Flue gas sample point | 1 |
| Air inlet sample point | 2 |

Table 20 Key to figure 53

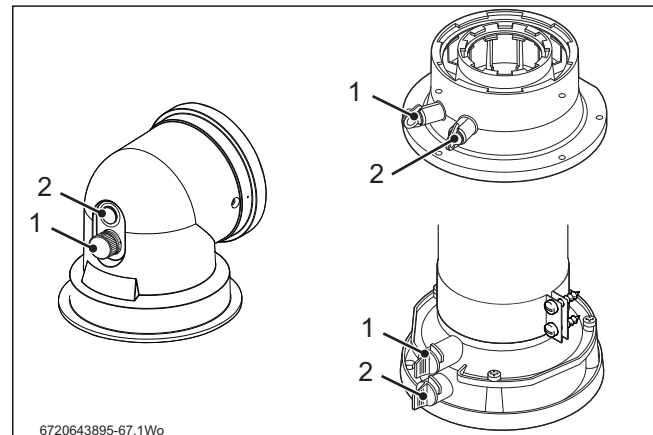

Fig. 53 Flue turret test points

With the boiler case on and the boiler running at maximum output (refer to paragraph "SET THE BOILER TO MAXIMUM", page 35).

- ▶ Ensure that the probe reaches the centre of the air intake, adjust the cone on the probe so that it seals the sample point and correctly positions the end of the probe.
- ▶ Insert the analyser probe into the air intake sample point.
- ▶ Allow the readings to stabilise and check that:
 - O₂ is equal to, or greater than 20.6%.
 - CO₂ is less than 0.2%
- ▶ If the readings are outside these limits then this indicates that there is a problem with the flue system or combustion circuit, e.g. missing or dislodged seals.

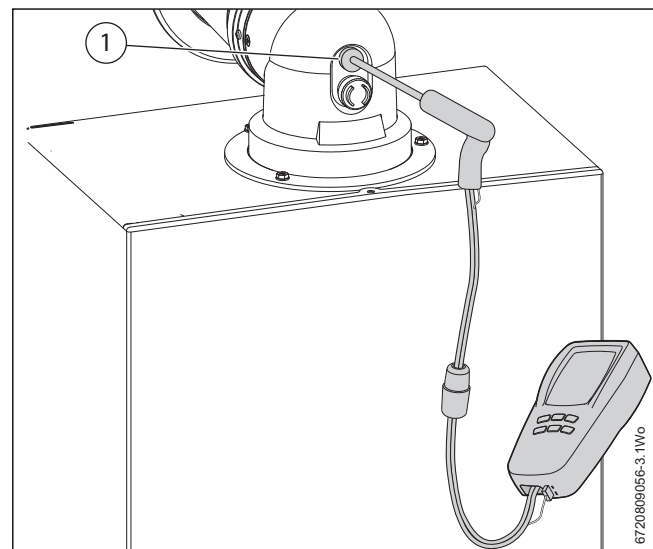

Fig. 54 Flue integrity test

6.1.3 Component Access

Removing outer case

1. Remove bottom panel by pulling it forward and off.
2. Undo but do not remove the 2 screws (A) securing boiler casing at the bottom of the appliance.
3. Pull upwards to release the clip (B) on top of the boiler.
4. Pull case forward and remove.

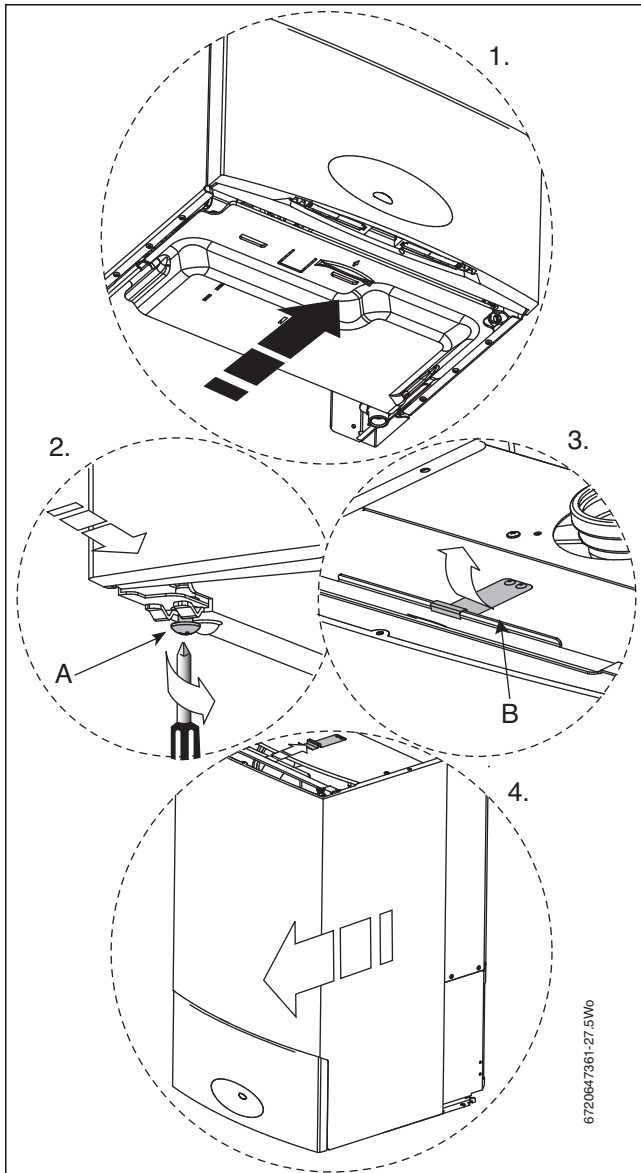

Fig. 55 Removing outer case

Adjusting boiler control to service position.

1. Pull down the catch securing the control panel.
2. Gently pull forward until it comes to rest in service position.

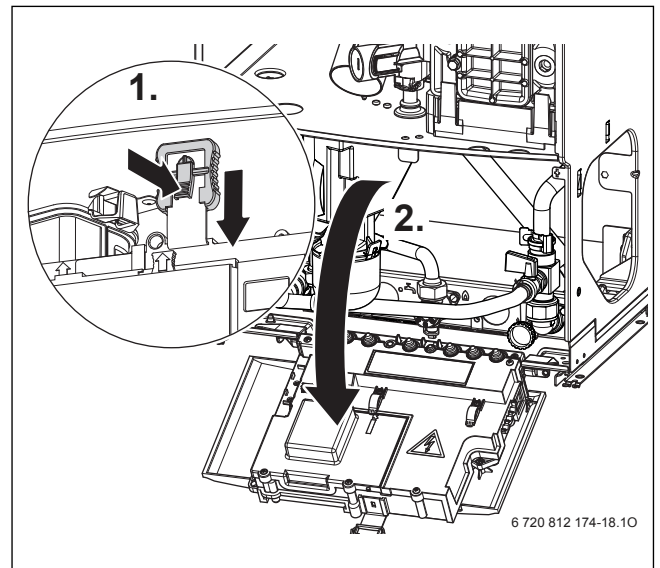

Fig. 56 Service position

6.1.4 Fan pressure test



This test is to determine if the heat cell requires cleaning/attention

SET THE BOILER TO MAXIMUM



The boiler must operate at maximum output for the Fan Pressure test and Flue Gas Analysis.

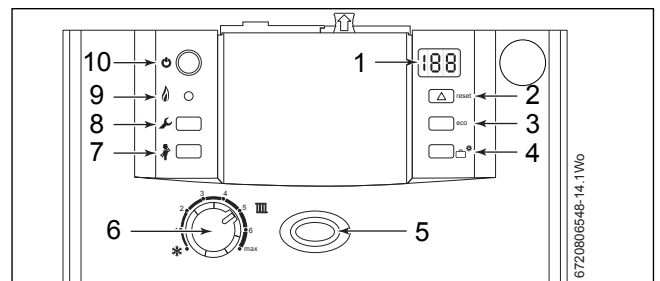

Fig. 57 Control panel

- [1] Display
- [2] Reset button
- [3] Not used
- [4] Not used
- [5] ON/OFF and fault indicator (Blue)
- [6] Central heating temperature control
- [7] Performance test button
- [8] Service button
- [9] Burner indicator (Green)
- [10] ON/OFF button

- ▶ Press and HOLD performance test button (7) for 10 seconds and set Central Heating temperature to maximum.
 - The performance test button will illuminate continually.
 - The boiler will stay in this mode for 15 minutes unless the performance test button is pressed again.
- ▶ Pull the cover off and connect a manometer to the fan pressure test point.
- ▶ After measurement replace test point cover.

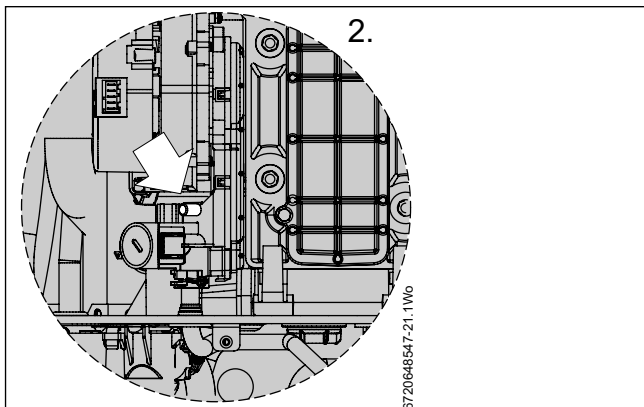

Fig. 58 Fan pressure test point

- Pressure readings in the black area will indicate that the heat exchanger requires attention/cleaning.
- There is a special accessory kit available specifically designed for cleaning the heat exchanger. Part number 7 719 001 996.

FAN PRESSURE TEST



NG Boilers

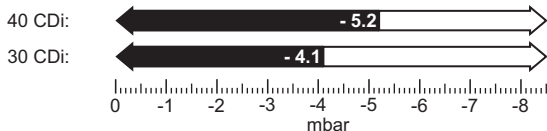

LPG Boilers

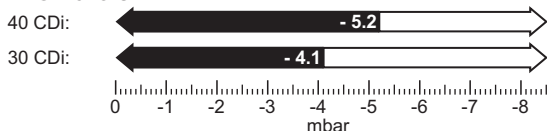

6720648547-26.1Wo

Fig. 59 Fan pressure readings

6.1.5 To Clean the Heat Exchanger

- Remove outer case and base panel and isolate the appliance from power.
1. Remove the cleaning access cover (B), seal (C) and metal plate (D) securing it, if present.

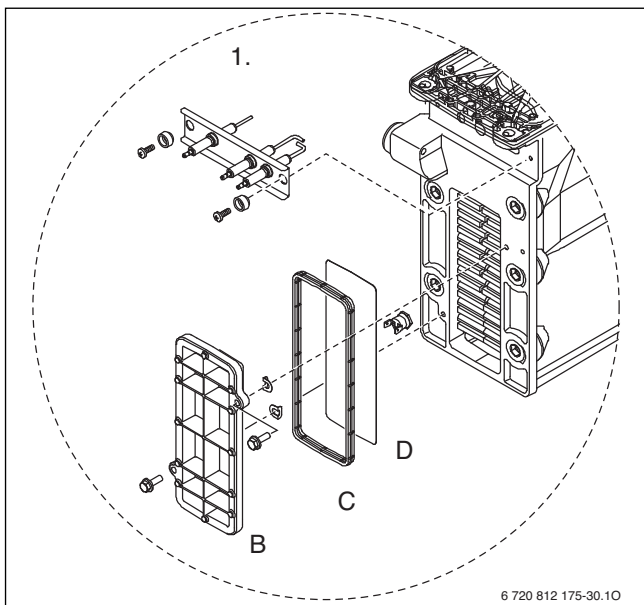

Fig. 60 Cleaning the heat exchanger

2. Loosen any deposits in the heat exchanger from top to bottom using the cleaning blade.

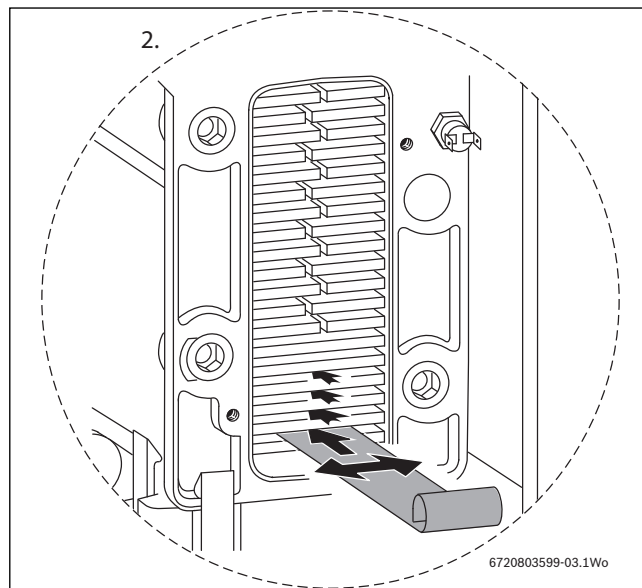

Fig. 61

3. Clean the heat exchanger from top to bottom using the brush.

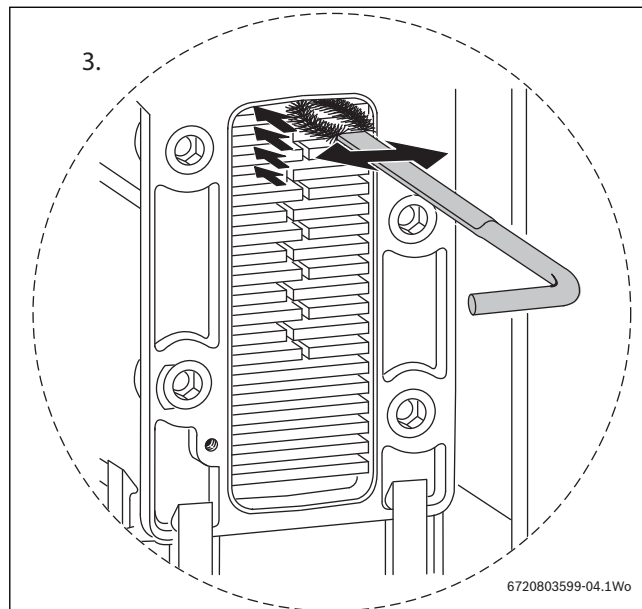

Fig. 62

- Refit the clean out cover plates in reverse order using a new seal (C) and tighten screws.

6.1.6 To Clean the Burner

1. Remove cover panel (A) by removing the screws (B).
- Check that the boiler is completely isolated from the gas supply.

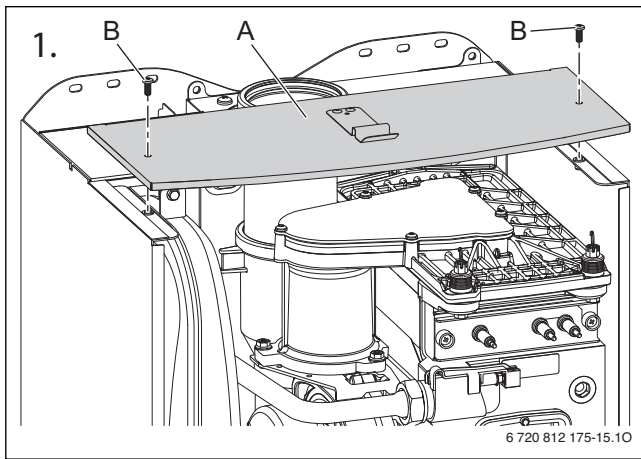

Fig. 63

2. Remove the clips (C) and unscrew the two bolts (D).
 - ▶ Unscrew and remove the two hexagon screws (E) securing the fan.
 - ▶ Slacken fully the rear securing bolt (F).
 - ▶ Remove the burner cover plate (G).

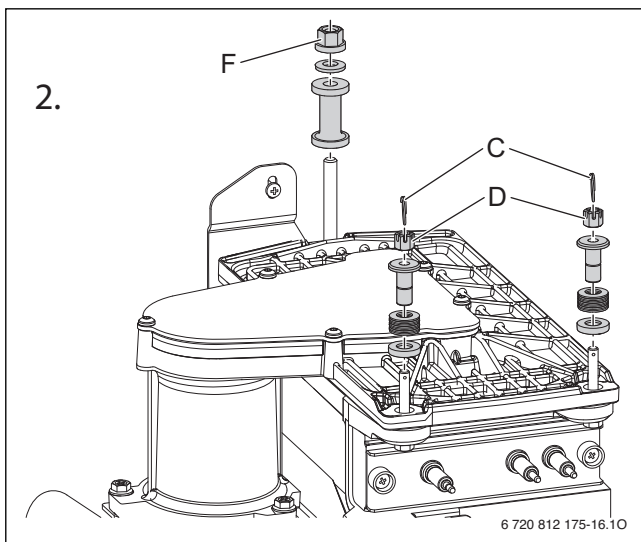

Fig. 64 Burner cover securing detail

3. Remove the burner (H) and clean components. **Do not use a wire brush.**

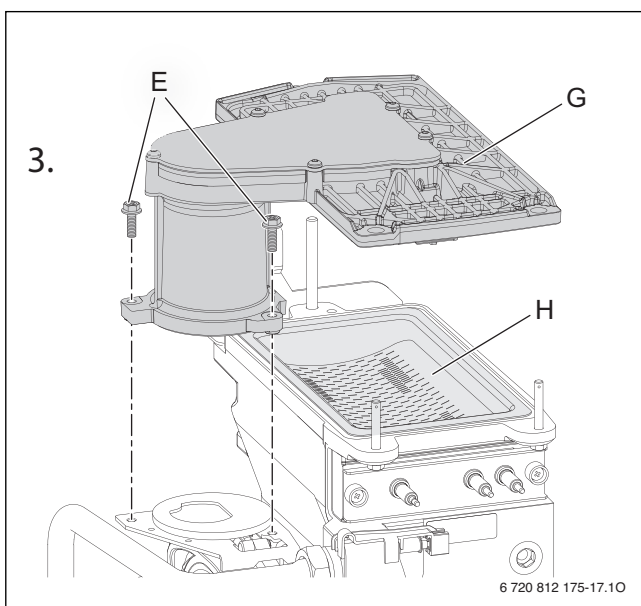

Fig. 65

6.1.7 To Check the Diaphragm in Burner Cover

4. Carefully withdraw diaphragm (J) from fan intake tube and check for soiling and splits.
 - ▶ Refit diaphragm (J) the correct way round into the fan intake tube

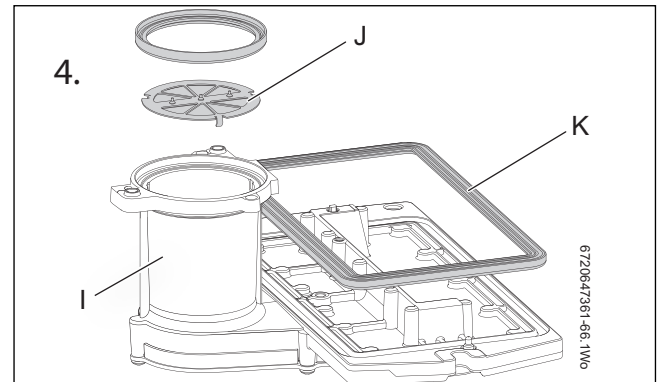

Fig. 66

6.1.8 Re-assembly of the burner cover

NOTICE: Burner gasket seal

- ▶ Always replace the burner gasket seal with a new when the joint has been disturbed

- ▶ Re-assemble the burner in the reverse order using a new seal (K)
- ▶ Insert the burner cover under the rear securing bolt and tighten down
- ▶ Assemble the washer, spring, spacer and castellated nut (D), refer to figure 64, onto the screws securing the burner cover to the heat exchanger.
- ▶ Using a 10mm spanner, tighten the castellated nuts (D), securing the burner cover (G) to the heat exchanger, until the spacers "bottom out" on the heat exchanger body. The nut will stop turning at this point, do not overtighten.
- ▶ If necessary, back the nuts off slightly until the hole for the clip (C) is visible
- ▶ Insert the clips (C) and secure
- ▶ After re-assembly, check the air/gas ratio and adjust if necessary. Refer to section 6.2 "Setting the air/gas ratio"

6.1.9 To Clean the Condensate Trap

1. Pull condensate hose out of the trap.
2. Remove the trap from boiler
 - ▶ Clean the trap and check that the connection to the heat exchanger is clear
 - ▶ Fill the condensate trap with approximately 250 millilitres of water and refit in reverse order

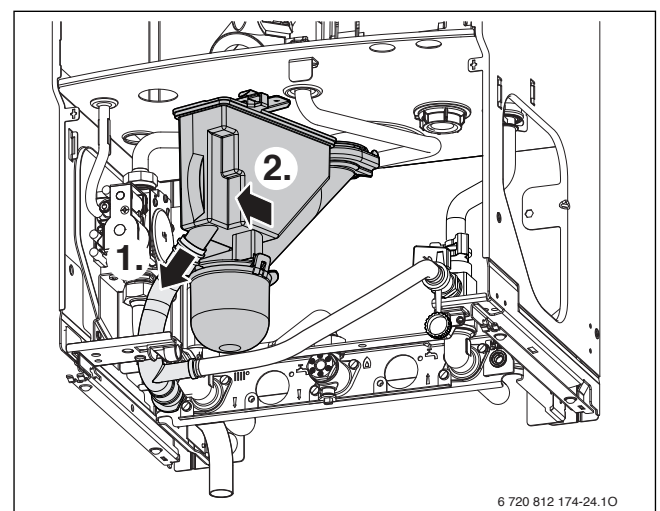

Fig. 67 Siphon removal

6.2 Setting the air/gas ratio



NOTICE: Air/Gas ratio

- ▶ The setting of the gas ratio must be carried out by a competent person. Setting the air/gas ratio must not be attempted unless the person carrying out the operation is equipped with a combustion analyser conforming to BS 7927 and is competent in its use.

Setting the CO₂



When running in the performance test mode ensure the motorised valve(s) are open to avoid the boiler cycling during the commissioning operation

1. Connect manometer to inlet test point on the gas valve.
 - ▶ To adjust the CO₂ it will be necessary to first operate the boiler at maximum output.
 - ▶ Press and hold down the performance test button for 10 seconds until illuminated.
2. Turn central heating control to maximum; the boiler will then go to maximum output.



The control will resume normal operation after 15 minutes or if the performance test button is pressed for over a second.

3. Using a flat blade screwdriver set the CO₂ via the max adjuster referring to the table below.



CO₂ should be measured 10 minutes after firing the appliance.

| Gas type | CO ₂ setting maximum | CO ₂ setting minimum |
|------------------------------------------------------|---------------------------------|---------------------------------|
| Greenstar 30CDi Classic Regular^{ErP} | | |
| Natural gas | 9.6% ±0.4 | 9.0% ±0.4 |
| LPG | 11.5% ±0.4 | 10.5% ±0.4 |
| Greenstar 40CDi Classic Regular^{ErP} | | |
| Natural gas | 9.7% ±0.4 | 9.1% ±0.4 |
| LPG | 11.5% ±0.4 | 10.5% ±0.4 |

NOTE: When checking an existing appliance the tolerance is ± 0.4%. If checking after cleaning or component replacement or for adjustment when the reading is outside the tolerance given above, then the tolerance is ± 0.2%

CO - less than 200 ppm (0.002 ratio)

- ▶ Check CO is less than 200 ppm.
 - ▶ Measure the gas inlet pressure at the gas valve test point; it should be a maximum of 2.5mbar less than the pressure at the meter for natural gas and a maximum of 4mbar less than the pressure at the regulator for LPG.
4. Set the central heating control to minimum. This will make the boiler go to minimum power.
 5. Measure the CO₂; it should now be at the figure for minimum output.
 - ▶ If not, use a 4mm Allen key to adjust the min adjustment on the gas valve until correct.
 - ▶ Return to maximum and re-check the CO₂.
 - ▶ If correct press and hold down the performance test button for two seconds; the button will cease to be illuminated and the blue power indicator will be permanently illuminated.
 - ▶ Remove manometer and re-seal inlet pressure point on gas valve.
 - ▶ Fit new plastic sealing cover onto the max adjuster.
 - ▶ Replace the brass screw over the min adjuster on the valve.
 - ▶ Re-assemble and refit boiler case.

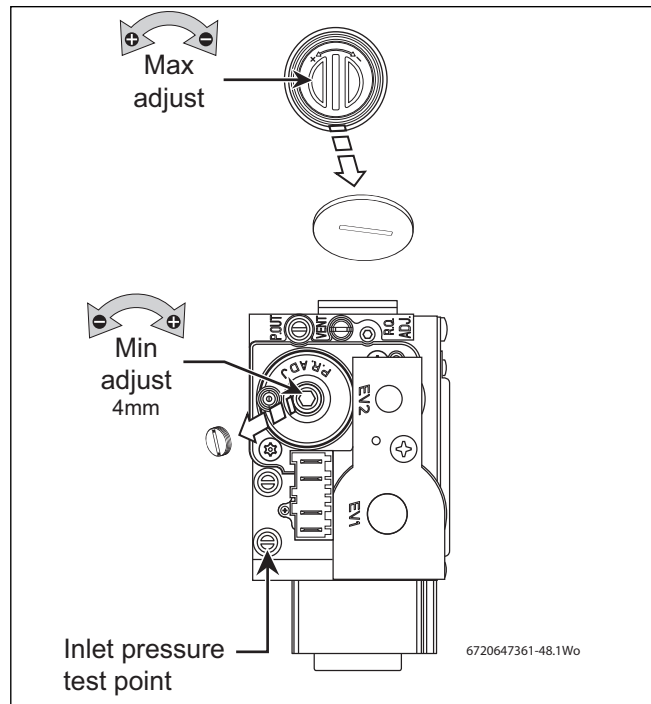



Fig. 68 Setting the Air/Gas ratio

6.3 Replacement of parts

 **CAUTION:** Isolate the mains gas supply before starting any work and observe all relevant safety precautions.

 **NOTICE:** After replacement of any components always check for gas tightness where relevant and carry out functional checks as described in commissioning. Any O-rings or gaskets that are disturbed during servicing must be replaced.

Removing outer case

1. Remove bottom panel by pulling it forward and off.
2. Loosen but do not remove the two screws (A) securing boiler casing at the bottom of the appliance.
3. Pull upwards to release the clip (B) on top of the boiler.
4. Pull case forward and remove.

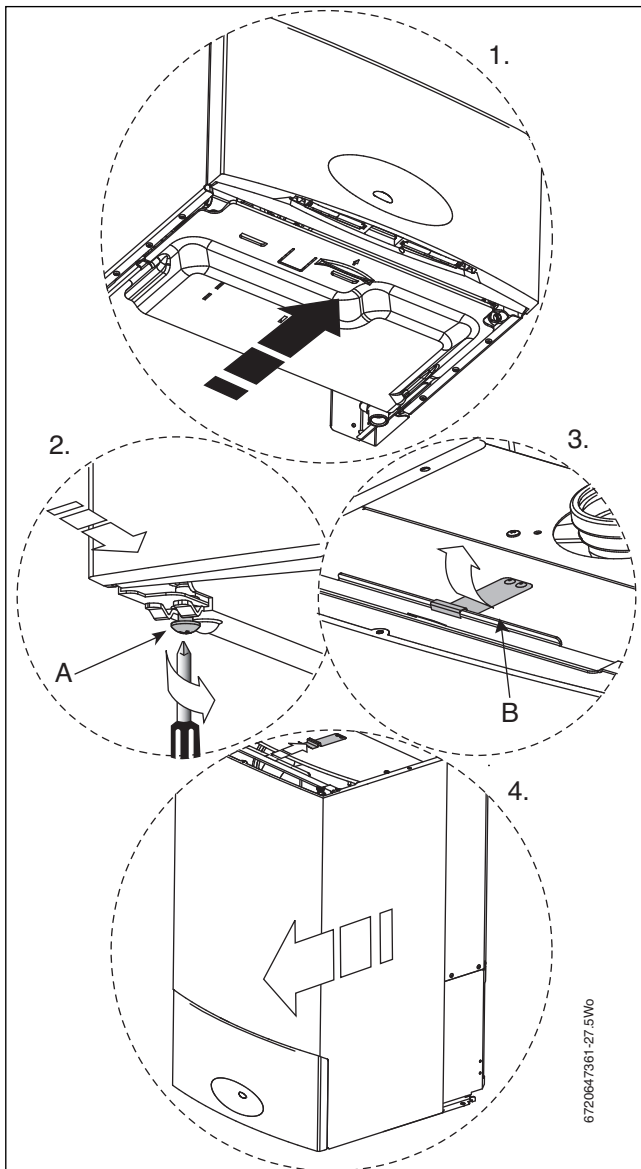

Fig. 69 Removing outer case

Adjusting boiler control to service position.

1. Pull down the catch securing the control panel.
2. Gently pull forward until it comes to rest in service position.

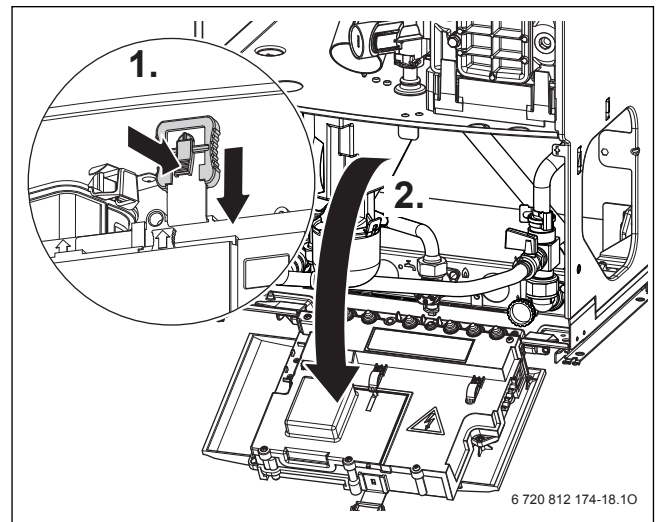

Fig. 70 Service position

Primary sensor

- ▶ Press retaining clip on plastic moulding and pull upwards until clear of pocket in heat exchanger.
- ▶ Separate sensor from connector, coat new sensor with heat conductive paste and replace.

Overheat thermostat

- ▶ Remove two electrical connectors from thermostat.
- ▶ Unscrew the sensor.

Flue limit thermostat

- ▶ Remove electrical connections.
- ▶ Unscrew thermostat from flue.

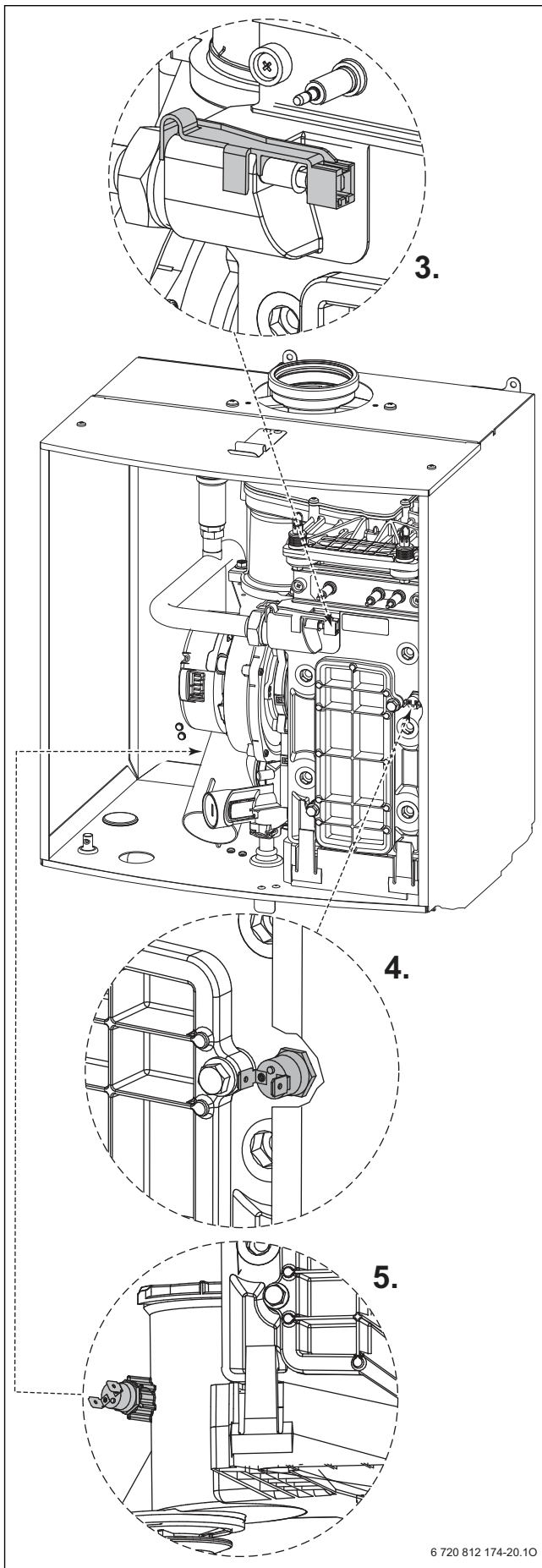

Fig. 71 Sensors

7. GAS VALVE

- ▶ Isolate gas supply at boiler gas cock.
- ▶ Pull out air inlet tube (A).
- ▶ Undo top gas connection (B) to gas valve.
- ▶ Undo bottom gas connection (C) to gas valve.
- ▶ Undo two securing screws (D) on the underside of casing.
- ▶ Pull valve up and forward out of boiler.
- ▶ Disconnect electrical connections.
- ▶ Replace valve with new seals and check for gas soundness.



The valve will require setting, follow procedure "Setting the gas/air ratio" in the gas conversion section.

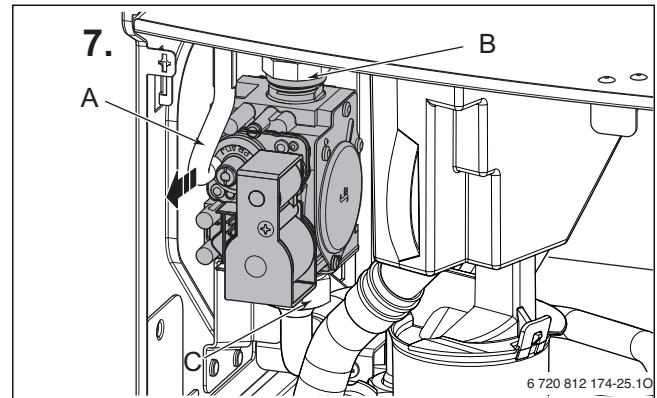

Fig. 72 Gas valve removal

8. Siphon/condensate trap

1. Pull condensate pipe out of the adaptor.
 2. Remove trap from boiler.
- ▶ Clean trap and check that the connection to the heat exchanger is clear.
 - ▶ Fill the condensate trap with approximately 1/4 litre of water and refit in reverse order.

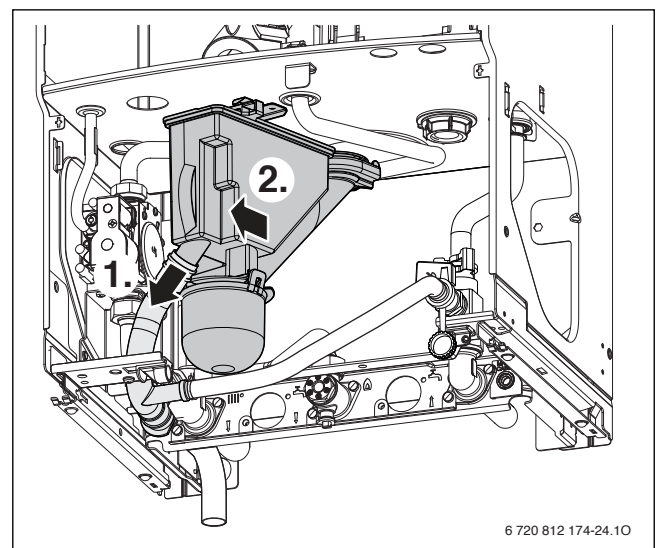

Fig. 73 Siphon removal

9. ACCESS TO BOILER CONTROL COMPONENTS

- ▶ Remove 3 screws (A) and remove cover from control.

10. PCB fuse

- ▶ Remove fuse (B) from the PCB and replace.
- ▶ There is a spare fuse clipped into the cover.

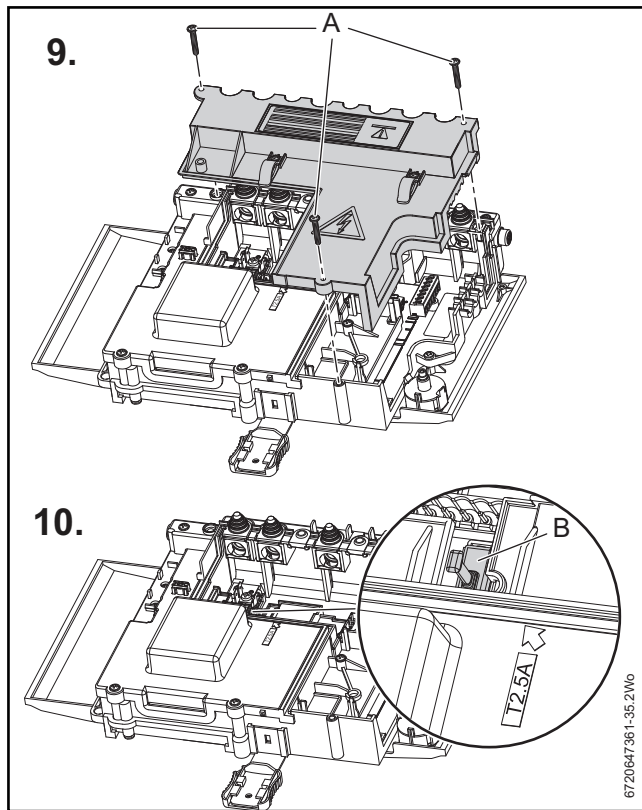

Fig. 74 Component and fuse access

11. PCB REMOVAL

To gain access to the PCB:

- ▶ Remove the five screws shown in the diagram below and remove the PCB cover.

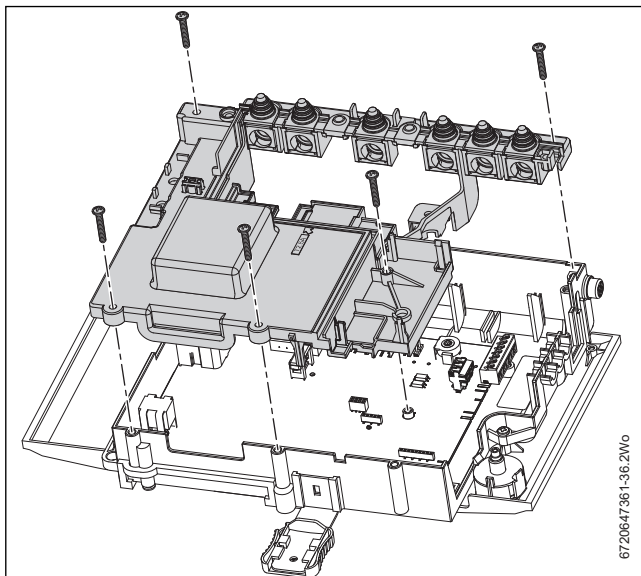

Fig. 75 PCB access

12. Fan assembly



NOTICE: Air/Gas ratio

- ▶ After re-assembly the combustion must be checked using the procedure in the section "Setting the air/gas ratio."
- ▶ The setting of the gas ratio must be carried out by a competent person. Setting the air/gas ratio must not be attempted unless the person carrying out the operation is equipped with a combustion analyser conforming to BS 7927 and is competent in its use.

- ▶ Remove electrical connector from fan.
 - ▶ Remove condensate trap (see page 40).
1. Undo the union connection (A) from the top of the gas valve.
- ▶ Remove wire clip (B) from air/gas adjustment assembly (C) then pull gas pipe down.
2. Unscrew two screws (D).
 3. Remove fan from boiler.
 4. Remove three screws retaining the air/gas adjustment assembly (E).
- ▶ Reassemble with new fan assuring that seals are correctly fitted.

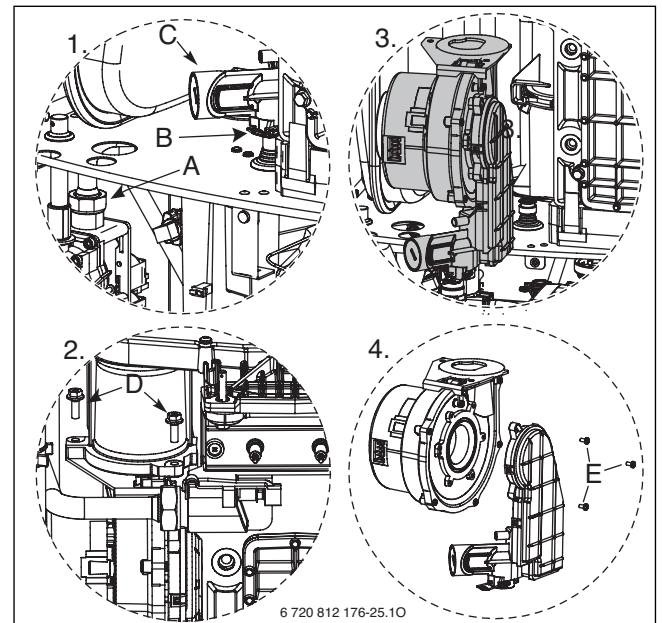

Fig. 76 Fan assembly removal

13. Electrode assembly

WARNING: Electrode gasket

- ▶ Do not remove the electrode assembly unless a new gasket is available for re-assembly.

- ▶ Disconnect spark electrodes and flame sensor connection.
- ▶ Remove two screws (F).
- ▶ Remove spark/flame electrode assembly (G) from heat exchanger.
- ▶ Inspect the spark/flame electrode assembly and ceramics for signs of contamination or damage, replace as necessary.
- ▶ If necessary, clean the spark/flame electrode assembly with a plastic scouring pad.
- ▶ Replace electrode gasket.
- ▶ Re-assemble with the new gasket and secure with the screws (F) removed earlier.

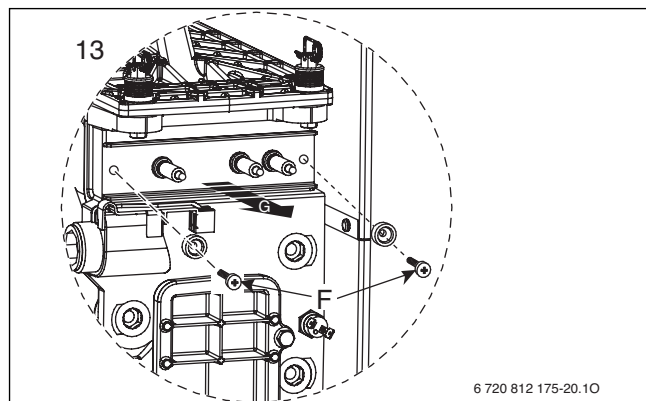

Fig. 77 Electrode assembly

14. Air/gas manifold

WARNING: Air/Gas manifold

- ▶ Do not remove the manifold unless a new gasket is available for re-assembly.

1. Remove cover panel (A) by removing screws (B).
- ▶ Check that the boiler is completely isolated from the gas supply.

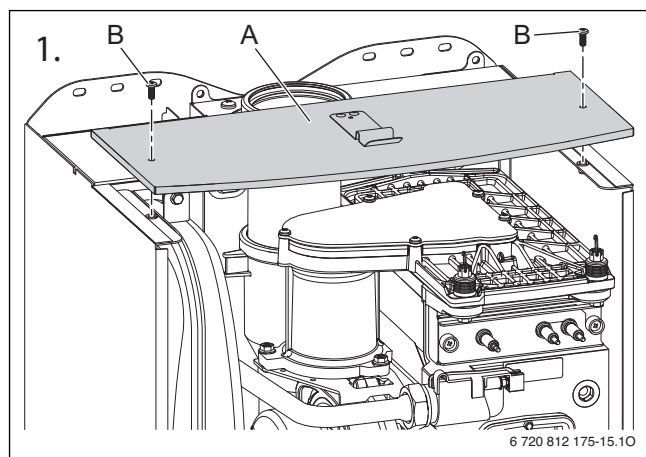

Fig. 78 Top panel

2. Remove clips (C) and unscrew the two bolts (D).
- ▶ Unscrew and remove the two hexagon screws (E) securing the fan.
- ▶ Slacken the rear securing bolt (F).

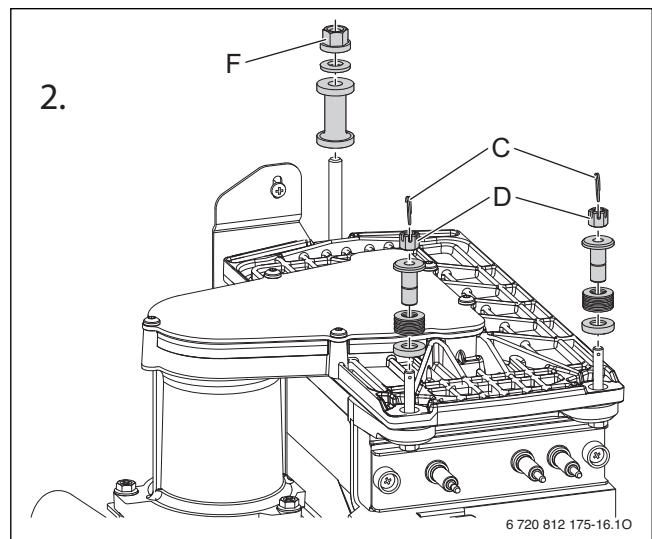

Fig. 79 Release air/gas manifold

3. Remove air/gas manifold (I)

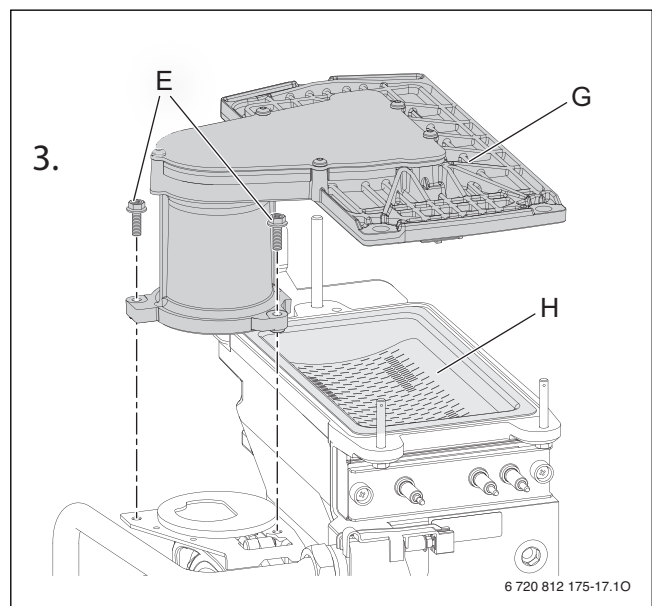

Fig. 80 Air/gas manifold

4. Open air/gas manifold (I).
- ▶ Carefully withdraw diaphragm (J) from fan intake tube and check for soiling and splits.

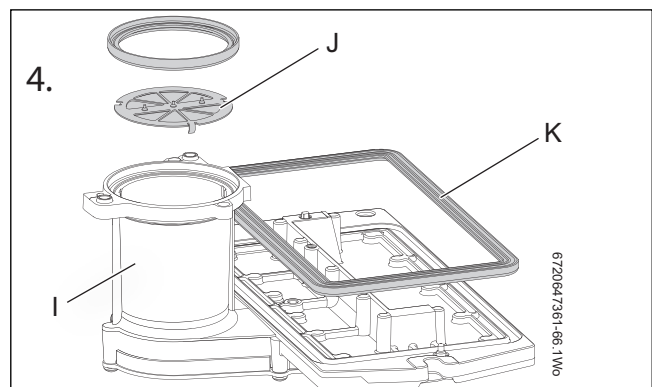

Fig. 81 Diaphragm

15. BURNER

- ▶ Remove the burner (H).
- ▶ Replace new burner in correct position.

- ▶ Refer to section 6.1.8 “Re-assembly of the burner cover”
- ▶ Ensure that a new seal (K) is used, refer to fig. 81.

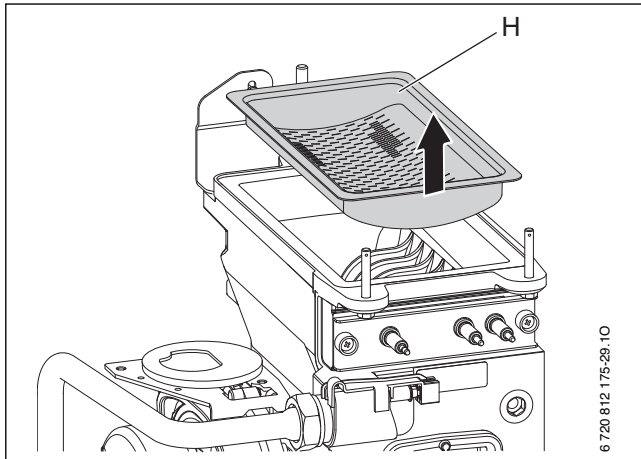

Fig. 82 Burner removal

16. Heat exchanger

- ▶ Isolate flow and return valves and drain the boiler.
 - ▶ Remove condensate trap (see page 40).
 - ▶ Remove fan assembly (see page 41).
1. Remove plastic nut (A) from the base of the inner casing

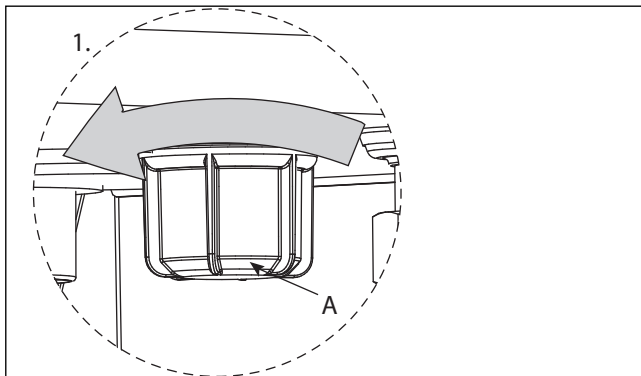

Fig. 83 Heat exchanger removal 1

2. Remove screw at the top of the heat exchanger (B).
- ▶ Unscrew the flow pipe (C).

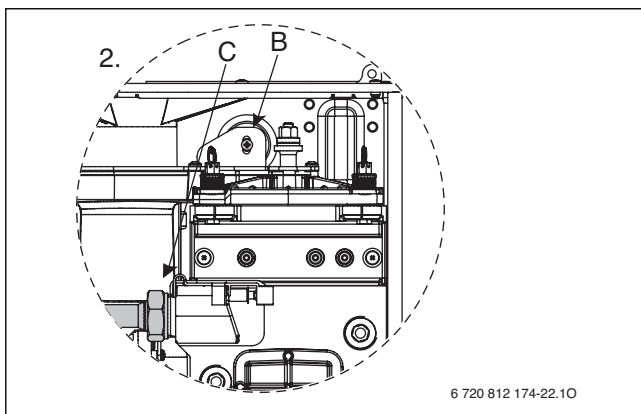

Fig. 84 Heat exchanger removal 2

3. Undo flue connection (D) from sump (E).
- ▶ Pull flue pipe up.
 - ▶ Remove the heat exchanger.

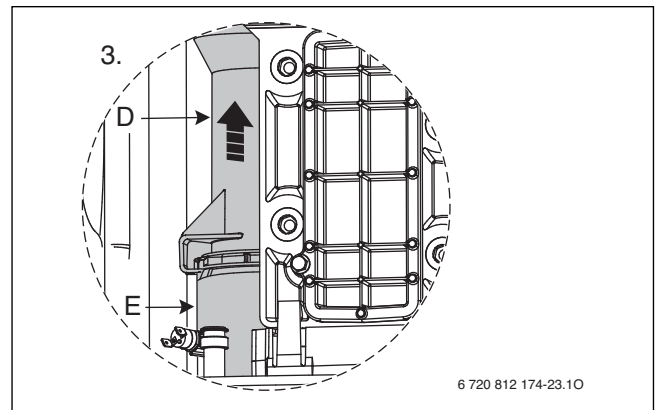

Fig. 85 Heat exchanger removal 3

19. DRAIN TAP

- ▶ Remove clip (G)
- ▶ Unscrew nut (H)
- ▶ Replace drain tap.

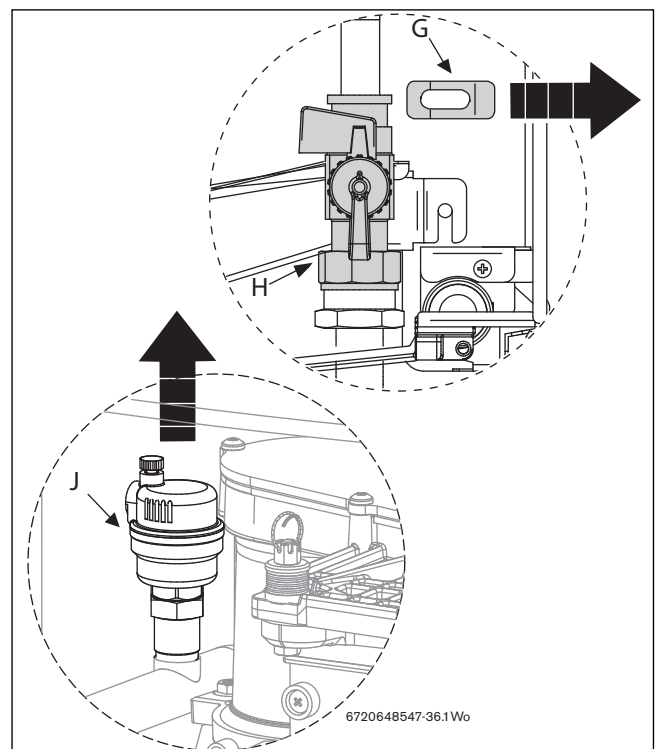

Fig. 86 Auto Air Vent removal

20. AUTO AIR VENT

- ▶ Ensure the appliance has been fully drained.
- ▶ Unscrew air vent (J) and replace.

6.4 Short parts list





| | | | |
|-------------------------------------------------------------------------------------|------------------------------------------------------------------------|-------------------------------------------------------------------------------------|---------------------------------------------------------------------|
|  | <p>Fan 8 717 204 453 0 GC No. H26 536</p> |  | <p>Burner 8 718 006 658 0 GC No. E27 200</p> |
|  | <p>Burner skin seal 8 711 004 166 0 GC No. E27 201</p> |  | <p>Gas valve 8 718 221 347 0 GC No. H56 469</p> |
|  | <p>Temperature limit sensor 8 722 963 858 0 GC No. H08 291</p> |  | <p>Electrodes 8 718 664 301 0 GC No. H22 458</p> |
|  | <p>Control sensor - primary 8 714 500 087 0 GC No. E74 53</p> |  | <p>Flue overhear thermostat 8 710 506 267 0</p> |
|  | <p>Control unit 8 717 207 833 0</p> |  | <p>Bearing plate (fan intake diaphragm) 8 715 505 883 0</p> |
|  | <p>Heat exchange inspection cover seal 8 710 103 153 0</p> |  | <p>Flue sample plug air intake 8 716 111 253 0</p> |
|  | <p>Flue sample point 8 716 111 252 0</p> | | |

Table 21

7 FAULT FINDING & DIAGNOSIS

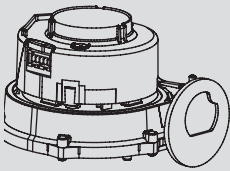
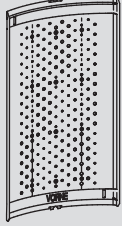
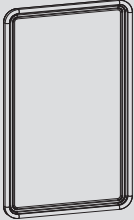
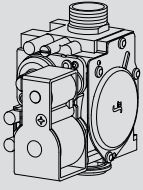
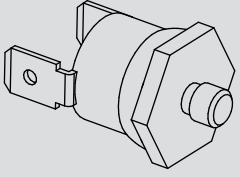
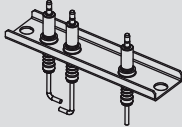
7.1 Fault finding

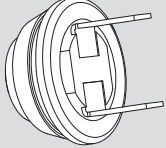
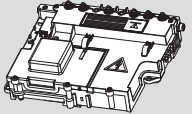
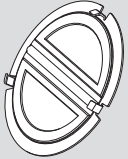
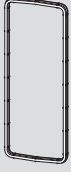

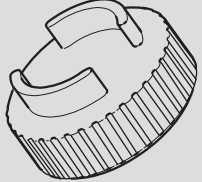
This fault finding information is for guidance only. Worcester Bosch cannot be held responsible for costs incurred by persons not deemed to be competent.

The electronic control system for this boiler incorporates a blue central indicator. This normally confirms the permanent mains supply but, by flashing during a fault, provides a guide to the cause as listed.

This fault finding system assumes that the appliance has been operating normally until the time of failure (i.e. not a first installation error).

PRELIMINARY CHECKS: Preliminary electrical system checks are the first electrical checks to be carried out during a fault-finding procedure. On completion of the Service/Fault-Finding task which has required the breaking and remaking of electrical connections, check:

- (a) EARTH CONTINUITY
- (b) SHORT CIRCUIT CHECK
- (c) POLARITY
- (d) RESISTANCE TO EARTH

| Display code | Description | Remedy |
|--------------|----------------------------------------------------|-------------------------------------------------------------------------------------------------------------------------------------------------------------|
| b1 | Code plug not detected. | Insert code plug correctly, test and replace if necessary. |
| C6 | Fan speed too low. | Check fan lead and connector, and fan; replace as necessary. |
| E2 | CH flow NTC sensor defective. | Check CH flow NTC sensor and connecting lead. |
| E9 | Safety temperature limiter in CH flow has tripped. | Check system pressure, check safety temp. limiters, check pump operation, check fuse on pcb, bleed appliance. |
| EA | Flame not detected. | Is gas cock turned on? Check gas supply pressure, power supply, igniter electrode and lead, ionisation sensing electrode and lead, flue duct and CO2 level. |
| F0 | Internal error. | Check electrical connector contacts, programmer inter-face module ignition leads are not loose; replace pcb if necessary. |
| F7 | Flame detected even though appliance switched off. | Check electrode assembly, dry pcb. Flue clear? |
| FA | Flame detected after gas shut off. | Check gas valve and wiring to gas valve. Clean condensation trap and check electrode assembly. Flue clear? |
| Fd | Reset button pressed by mistake | Press reset button again |

Table 22

A more detailed fault finding procedure is described in the Service Engineer's booklet.

7.2 Protection function (external pump)

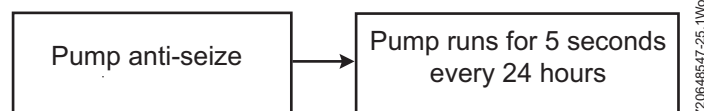

6720648647-25-1Wo

SERVICE RECORD

It is recommended that your heating system is serviced regularly and that the appropriate Service Interval Record is completed.

Service Provider

Before completing the appropriate Service Record below, please ensure you have carried out the service as described in the manufacturer's instructions. Always use the manufacturer's specified spare part when replacing controls.

| | | | | | |
|-----------------------|--------------------------------|----|-----|------------|-------------------|
| SERVICE 01 | | | | | Date: |
| Engineer name: | | | | | |
| Company name: | | | | | |
| Telephone No: | | | | | |
| Gas safe register No: | | | | | |
| Record: | At max. rate: | CO | ppm | AND | CO ₂ % |
| | At min. rate: (Where Possible) | CO | ppm | AND | CO ₂ % |
| Comments: | | | | | |
| Signature | | | | | |

| | | | | | |
|-----------------------|--------------------------------|----|-----|------------|-------------------|
| SERVICE 02 | | | | | Date: |
| Engineer name: | | | | | |
| Company name: | | | | | |
| Telephone No: | | | | | |
| Gas safe register No: | | | | | |
| Record: | At max. rate: | CO | ppm | AND | CO ₂ % |
| | At min. rate: (Where Possible) | CO | ppm | AND | CO ₂ % |
| Comments: | | | | | |
| Signature | | | | | |

| | | | | | |
|-----------------------|--------------------------------|----|-----|------------|-------------------|
| SERVICE 03 | | | | | Date: |
| Engineer name: | | | | | |
| Company name: | | | | | |
| Telephone No: | | | | | |
| Gas safe register No: | | | | | |
| Record: | At max. rate: | CO | ppm | AND | CO ₂ % |
| | At min. rate: (Where Possible) | CO | ppm | AND | CO ₂ % |
| Comments: | | | | | |
| Signature | | | | | |

| | | | | | |
|-----------------------|--------------------------------|----|-----|------------|-------------------|
| SERVICE 04 | | | | | Date: |
| Engineer name: | | | | | |
| Company name: | | | | | |
| Telephone No: | | | | | |
| Gas safe register No: | | | | | |
| Record: | At max. rate: | CO | ppm | AND | CO ₂ % |
| | At min. rate: (Where Possible) | CO | ppm | AND | CO ₂ % |
| Comments: | | | | | |
| Signature | | | | | |

| | | | | | |
|-----------------------|--------------------------------|----|-----|------------|-------------------|
| SERVICE 05 | | | | | Date: |
| Engineer name: | | | | | |
| Company name: | | | | | |
| Telephone No: | | | | | |
| Gas safe register No: | | | | | |
| Record: | At max. rate: | CO | ppm | AND | CO ₂ % |
| | At min. rate: (Where Possible) | CO | ppm | AND | CO ₂ % |
| Comments: | | | | | |
| Signature | | | | | |

| | | | | | |
|-----------------------|--------------------------------|----|-----|------------|-------------------|
| SERVICE 06 | | | | | Date: |
| Engineer name: | | | | | |
| Company name: | | | | | |
| Telephone No: | | | | | |
| Gas safe register No: | | | | | |
| Record: | At max. rate: | CO | ppm | AND | CO ₂ % |
| | At min. rate: (Where Possible) | CO | ppm | AND | CO ₂ % |
| Comments: | | | | | |
| Signature | | | | | |

| | | | | | |
|-----------------------|--------------------------------|----|-----|------------|-------------------|
| SERVICE 07 | | | | | Date: |
| Engineer name: | | | | | |
| Company name: | | | | | |
| Telephone No: | | | | | |
| Gas safe register No: | | | | | |
| Record: | At max. rate: | CO | ppm | AND | CO ₂ % |
| | At min. rate: (Where Possible) | CO | ppm | AND | CO ₂ % |
| Comments: | | | | | |
| Signature | | | | | |

| | | | | | |
|-----------------------|--------------------------------|----|-----|------------|-------------------|
| SERVICE 08 | | | | | Date: |
| Engineer name: | | | | | |
| Company name: | | | | | |
| Telephone No: | | | | | |
| Gas safe register No: | | | | | |
| Record: | At max. rate: | CO | ppm | AND | CO ₂ % |
| | At min. rate: (Where Possible) | CO | ppm | AND | CO ₂ % |
| Comments: | | | | | |
| Signature | | | | | |

| | | | | | |
|-----------------------|--------------------------------|----|-----|------------|-------------------|
| SERVICE 09 | | | | | Date: |
| Engineer name: | | | | | |
| Company name: | | | | | |
| Telephone No: | | | | | |
| Gas safe register No: | | | | | |
| Record: | At max. rate: | CO | ppm | AND | CO ₂ % |
| | At min. rate: (Where Possible) | CO | ppm | AND | CO ₂ % |
| Comments: | | | | | |
| Signature | | | | | |

| | | | | | |
|-----------------------|--------------------------------|----|-----|------------|-------------------|
| SERVICE 10 | | | | | Date: |
| Engineer name: | | | | | |
| Company name: | | | | | |
| Telephone No: | | | | | |
| Gas safe register No: | | | | | |
| Record: | At max. rate: | CO | ppm | AND | CO ₂ % |
| | At min. rate: (Where Possible) | CO | ppm | AND | CO ₂ % |
| Comments: | | | | | |
| Signature | | | | | |

73 **HEATING FUNCTION** All installers in England and Wales must be notified to Local Authority Building Control (LABC) either directly or through a Competent Persons Scheme. A Building Regulations Compliance Certificate will then be issued to the customer.



GAS BOILER SYSTEM COMMISSIONING CHECKLIST

This Commissioning Checklist is to be completed in full by the competent person who commissioned the boiler as a means of demonstrating compliance with the appropriate Building Regulations and then handed to the customer to keep for future reference.

Failure to install and commission according to the manufacturer's instructions and complete this Benchmark Commissioning Checklist will invalidate the warranty. This does not affect the customer's statutory rights.

| | | | | | | | | | |
|--------------------------------------------------------------------------------------------------------------------------------|------------------------------------------|--|----------------------------------------------|------------------------------|---------------------|--------------------|----------|-------------|----|
| Customer name: | | | | Telephone number: | | | | | |
| Address: | | | | | | | | | |
| Boiler make and model: | | | | | | | | | |
| Boiler serial number: | | | | | | | | | |
| Commissioned by (PRINT NAME): | | | | Gas Safe register number: | | | | | |
| Company name: | | | | Telephone number: | | | | | |
| Company address: | | | | | | | | | |
| | | | | Commissioning date: | | | | | |
| To be completed by the customer on receipt of a Building Regulations Compliance Certificate* | | | | | | | | | |
| Building Regulations Notification Number (if applicable): | | | | | | | | | |
| CONTROLS (tick the appropriate boxes) | | | | | | | | | |
| Time and temperature control to heating | Room thermostat and programmer/timer | | | Programmable room thermostat | | | | | |
| | Load/weather compensation | | | Optimum start control | | | | | |
| Time and temperature control to hot water | Cylinder thermostat and programmer/timer | | | Combination Boiler | | | | | |
| Heating zone valves | Fitted | | | Not required | | | | | |
| Hot water zone valves | Fitted | | | Not required | | | | | |
| Thermostatic radiator valves | Fitted | | | Not required | | | | | |
| Automatic bypass to system | Fitted | | | Not required | | | | | |
| Boiler interlock | | | | Provided | | | | | |
| ALL SYSTEMS | | | | | | | | | |
| The system has been flushed and cleaned in accordance with BS7593 and boiler manufacturer's instructions | | | | | | | Yes | | |
| What system cleaner was used? | | | | | | | | | |
| What inhibitor was used? | | | | | | | Quantity | litres | |
| Has a primary water system filter been installed? | | | | | | | Yes | No | |
| CENTRAL HEATING MODE measure and record: | | | | | | | | | |
| Gas rate | m ³ /hr | | OR | | ft ³ /hr | | | | |
| Burner operating pressure (if applicable) | mbar | | OR Gas inlet pressure | | mbar | | | | |
| Central heating flow temperature | | | | | | | °C | | |
| Central heating return temperature | | | | | | | °C | | |
| COMBINATION BOILERS ONLY | | | | | | | | | |
| Is the installation in a hard water area (above 200ppm)? | | | | | | | Yes | No | |
| If yes, and if required by the manufacturer, has a water scale reducer been fitted? | | | | | | | Yes | No | |
| What type of scale reducer has been fitted? | | | | | | | | | |
| DOMESTIC HOT WATER MODE Measure and Record: | | | | | | | | | |
| Gas rate | m ³ /hr | | OR | | ft ³ /hr | | | | |
| Burner operating pressure (at maximum rate) | mbar | | OR Gas inlet pressure at maximum rate | | mbar | | | | |
| Cold water inlet temperature | | | | | | | °C | | |
| Hot water has been checked at all outlets | | | | | | | Yes | Temperature | °C |
| Water flow rate | | | | | | | l/min | | |
| CONDENSING BOILERS ONLY | | | | | | | | | |
| The condensate drain has been installed in accordance with the manufacturer's instructions and/or BS5546/BS6798 | | | | | | | Yes | | |
| ALL INSTALLATIONS | | | | | | | | | |
| Record the following: | At max. rate: | | CO | ppm | AND | CO/CO ₂ | Ratio | | |
| | At min. rate: (where possible) | | CO | ppm | AND | CO/CO ₂ | Ratio | | |
| The heating and hot water system complies with the appropriate Building Regulations | | | | | | | Yes | | |
| The boiler and associated products have been installed and commissioned in accordance with the manufacturer's instructions | | | | | | | Yes | | |
| The operation of the boiler and system controls have been demonstrated to and understood by the customer | | | | | | | Yes | | |
| The manufacturer's literature, including Benchmark Checklist and Service Record, has been explained and left with the customer | | | | | | | Yes | | |
| Commissioning Engineer's Signature | | | | | | | | | |
| Customer's Signature | | | | | | | | | |
| (To confirm satisfactory demonstration and receipt of manufacturer's literature) | | | | | | | | | |

*All installations in England and Wales must be notified to Local Authority Building Control (LABC) either directly or through a Competent Persons Scheme. A Building Regulations Compliance Certificate will then be issued to the customer.



Worcester, Bosch Group
Cotswold Way, Warndon, Worcester WR4 9SW.
Tel. 0330 123 9559

Worcester, Bosch Group is a brand name of Bosch Thermotechnology Ltd.
worcester-bosch.co.uk

6 720 815 723 (2015/05)

WORCESTER, BOSCH GROUP:

TECHNICAL SUPPORT: 0330 123 3366
APPOINTMENTS: 0330 123 9339
SPARES: 0330 123 9779
LITERATURE: 0330 123 9119
TRAINING: 0330 123 0166
SALES: 0330 123 9669



WORCESTER
Bosch Group