

# ***Ocean Style* OF APPLIANCE CATEGORY 1N N**

## **WALL MOUNTED, GAS FIRED COMBINATION BOILER FOR USE WITH NATURAL GAS ONLY**

# **INSTALLATION, COMMISSIONING AND SERVICING INSTRUCTIONS**

Gas Safety (Installation and use) Regulations 1984:- It is the law that all gas appliances are installed by a competent person, in accordance with the above regulations. Failure to install appliances correctly could lead to prosecution. It is in your own interest, and that of safety, to ensure compliance with the law.

The installation of this appliance must be in accordance with the relevant requirements of the Gas Safety (Installation and use), 'Current' IEE Wiring Regulations, local building regulations and bye laws of the local water undertaking. It should be in accordance also with the relevant recommendations of the following British Standards and Codes of Practice: BS.5449:1:1977, BS.5546:1:1979, BS.5440:1:1990, BS.5440:2:1989, BS 6798:1987, BS.6891:1988 and BG.DM2

Manufacturer's instructions must NOT be taken in any way as over-riding statutory obligations

For Technical help or for Service call ...

**ALPHA HELPLINE**  
**Tel: (01322) 669443**

**Alpha**  
**BOILERS**

Goldsel Road,  
Swanley, Kent BR8 8EX  
Fax: (01322) 615017

# CONTENTS

<b>INTRODUCTION</b>			
1.	General Specification Details	Page	3
2.	External Heating Controls		3
3.	Electrical Supply		3
4.	Packaging		3
<b>GENERAL INFORMATION</b>			
	Technical Data - Tables 1 and 2		4
	Available Pump Heads - Table 3		4
<b>INSTALLATION INSTRUCTIONS</b>			
1.	Gas Supply		5
2.	Location of Boiler		5
3.	Flue Position - Fig. 2		5
4.	Air Supply - Table 5		6
<b>REQUIREMENTS FOR SEALED SYSTEMS</b>			
1.	General		8
2.	Pressure Gauge		8
3.	Safety Valve		8
4.	Pump		8
5.	Expansion Vessel		8
6.	System Volume - Table 6		8
7.	Filling and Venting the System		8
8.	System Checks - Fig. 3		9
<b>DOMESTIC HOT WATER SUPPLY TO THE BOILER AND OTHER APPLIANCES</b>			
1.	General		10
2.	Bidets		10
3.	Showers		10
4.	Domestic Hot and Cold Water Supply Taps and Mixing Valves		10
5.	Domestic Expansion Vessel		10
<b>REQUIREMENTS FOR ELECTRICAL WIRING</b>			
1.	General Safety		10
2.	Mains Supply Wiring to the Appliance - Fig. 4		10
3.	External Wiring of Heating Controls. Clock - Room Thermostat - Frost Thermostat - Fig. 5		11
	Appliance Wiring Diagram - Fig. 6		11
	Appliance Functional Flow Diagram - Fig. 7		12
<b>INSTALLATION OF THE APPLIANCE</b>			
1.	Fixing Templates - Hardware Supplied		13
2.	Fixing the Wall Mounting Plate		13
	Dimensional Relationship Between Appliance and Wall Face - Wall Mounting Requirements - Assembly of Upper Cross Bar - Fig. 9		14
3.	Making Service Connections, from the System to the Wall Plate		15
4.	Hanging the Boiler on the Wall Plate and Making Service Connections to the Boiler		15
5.	Commissioning the Appliance. Checks for Gas Soundness - Purging. Filling the System - Flushing. Control Panel - User Controls - Fig. 12.1		16
	Pilot Supply Pipe - Gas Soundness Check - Adjustment of Pilot Flame - Fig. 13.1	Page	17
	Procedure for Setting Central Heating and Domestic Hot Water Gas Pressure		17
6.	Checking Operation of the Central Heating / Domestic Hot Water Services / Safety Valve / Central Heating / Domestic Hot Water Bypass Adjustment. Final Adjustments and Requirements		18
7.	Instructions Provided for the User. Users Instruction Literature. Servicing Intervals.		18
<b>SERVICING THE APPLIANCE</b>			
1.	Annual Servicing - Routine Inspection and Cleaning		19
2.	Checks Undertaken Prior to Servicing		20
3.	Tools Required - Basic List		20
4.	Servicing of Components		20
	Specific order of removal for servicing - and reassembly		20/21
5.	Replacement of Component Parts		22
	Replacement of Components - Index.		22
	Replacement of thermocouple; Electrode lead; electrode; pilot injector; pilot burner bracket assembly with shield		22
	Replacement of control box components; Illuminated ON/OFF switch; Suppressor.		23
	Replacement of piezo spark generator		24
	Control Thermostat; Safety Thermostat; domestic hot water thermostat.		24
	Replacement of Overheat Thermostat		25
	Replacement of Gas Valve		25
	Replacement of Boiler Combustion Chamber insulation		26
	Replacement of components requiring isolation of the appliance from the central heating (primary) and domestic hot water (secondary) circuits and draining down the system: - Water Flow Switch		26
	Circulating Pump or Circulating Pump Motor.		26/27
	Replacement of Domestic Hot Water Heat Exchanger		28
	Replacement of microswitch cover assembly - domestic hot water pressurestat and diverter valve		28
	Replacement of Expansion vessel		29
	Replacement of Safety Valve; Stainless steel Domestic Hot Water pressure vessel (if fitted).		30
	Pressure gauge; Replacement of boiler heat exchanger		31
6.	SHORT PARTS LIST AND PHOTOGRAPH OF COMPONENT PARTS		32/34
7.	FAULT FINDING		35

# INTRODUCTION

## 1 General Specification Details

The Ocean OF Style is a wall mounted Open Flue combination boiler. Heat output is controlled through a HIGH/LOW gas valve fitted with permanent pilot.

The appliance is range rated to provide central heating outputs (LOW GAS VALVE ADJUSTMENT) between 17.6 kW (60,000 Btu/h) and 11.7 kW (40,000 Btu/h). Domestic hot water service (HIGH GAS VALVE PRESETTING) has priority at all times, and instant hot water is available at the boiler hot water flow outlet up to a maximum of 23.4 kW (80,000 Btu/h). Control over hot water output is achieved using the HIGH/LOW operation of the gas valve, i.e. at a predetermined maximum hot water temperature the heat output will commence to switch between HIGH and the LOW setting used for heating.

The boiler is designed for use with fully pumped, sealed and pressurised heating systems using NATURAL GAS ONLY. The appliance IS NOT SUITABLE for providing domestic hot water WITHOUT CONNECTION to a HEATING SYSTEM.

The Ocean OF Style is supplied fully assembled, with domestic hot water calorifier, diverter valve, circulating pump, pressure gauge, safety valve, and sealed system expansion vessel.

Within the boiler the functions of heating and domestic hot water operate separately; when there is a domestic hot water demand this takes priority. The functions are controlled from a dial on the control panel which may be set to Domestic Hot Water only (summer condition), or Domestic Hot Water and Heating (winter condition). A demand for domestic hot water is sensed in the boiler by detecting domestic hot water flow. This switches on the boiler at HIGH gas valve setting. The boiler switches from HIGH to LOW and LOW to OFF to achieve control of water outlet temperature. When there is no domestic water demand and when the external controls (eg room thermostat and timeswitch) call for heating then the boiler delivers heating at the required heat output set when commissioning. The central heating (LOW gas valve adjustment) output is preset at 14.06 kW (48,000 Btu/h).

When domestic hot water temperature is below 65 °C the boiler fires at HIGH setting. Above 65 °C the gas valve switches to LOW setting. If water draw off rate is low - minimum 3l/m (0.66 gpm) - the water temperature may rise up to a maximum of 80 °C before the boiler switches off. At high domestic water flows the delivery temperature will fall.

## 2 External Heating Controls

Provision is made at the boiler terminal strip for the connection of a heating time clock and room thermostat.

Thermostatic radiator valves may be used providing either a 22 mm by pass, with lockshield balancing valve, is fitted to ensure a minimum flow rate through the boiler of 9.86 l/m (2.17 gpm) when all radiator valves are closed, OR a single uncontrolled radiator with a minimum catalogue emission of 1.2 kW (4,100 Btu/h) is fitted.

## 3 Electrical Supply

The appliance is suitable for operation with a mains supply of 240 V ~ 50 Hz.

NOTE: The supply should be taken from an unswitched shuttered socket. The connection shall be adjacent to the appliance by means of a 3 pin plug, fused at 3 A. The plug and socket shall comply with BS 1363. Alternatively a double pole isolation switch MUST be used.

NOTE: If the electrical supply to the appliance is interrupted when the burner is firing it may be necessary, depending upon the particular operating condition, to reset the gas controls.

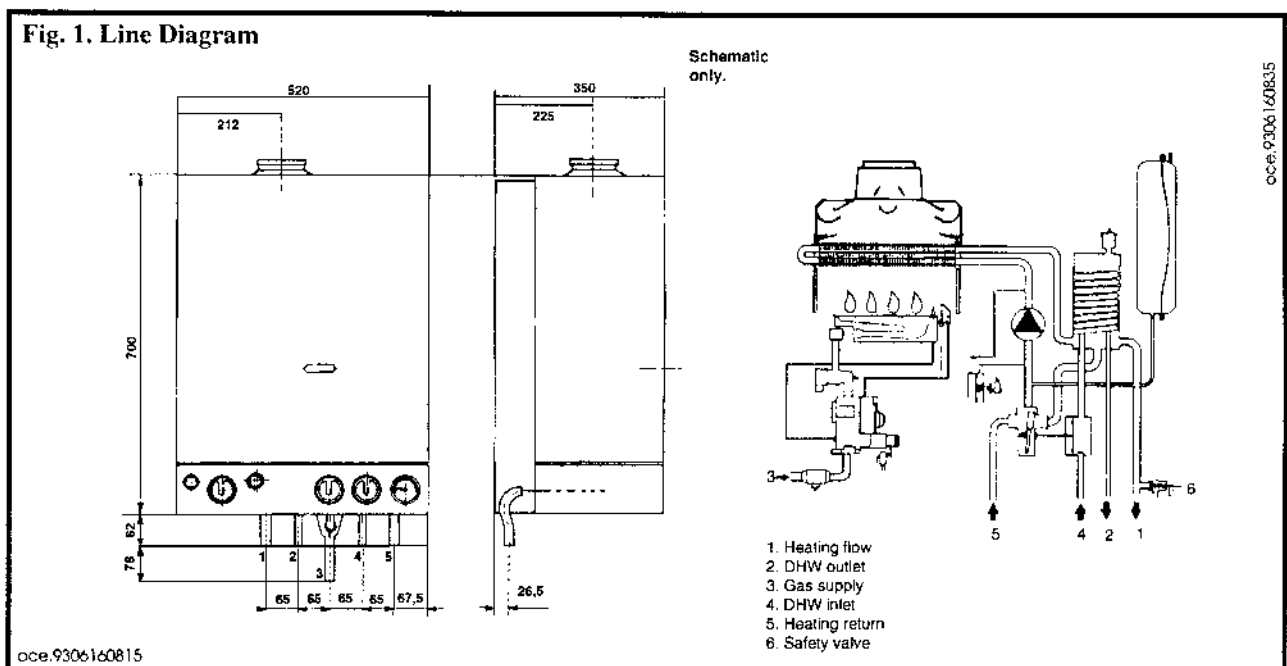
## 4 Packaging

The appliance is supplied in two cartons.

a) The largest carton contains the boiler literature and hinged panel.

b) The smallest carton contains the wall mounting plate, paper templates, fittings and other hardware.

When fixed in position the plate and its connections allows the installation to be completed up to the boiler connections without the boiler in position.



# GENERAL INFORMATION

## Technical Data

Note: - The appliance data plate is positioned under the boiler on the controls support plate

Table 1

NOMINAL BOILER RATINGS AT NORMAL OPERATING TEMPERATURE (10 minutes after lighting)								
OPERATION	OUTPUT		INPUT		BURNER SETTING PRESSURE		GAS RATE	
	kW	(Btu/h)	kW	(Btu/h)	mbar	(in.wg)	m <sup>3</sup> /h	(ft <sup>3</sup> /h)
REQUIRED HEATING OUTPUT AND LOW SETTING FOR DOMESTIC HOT WATER	17.6	60,000	22.06	75,277	7.6	3	2.05	72.59
*INITIAL FACTORY SETTING	11.7	40,000	14.9	50,959	3.4	1.4	1.39	49.14
WATER ONLY	*23.4	80,000	28.9	98,645	12.6	5	2.69	95.12

NOTE:- A minimum gas supply pressure of 20 mbar (8 in wg) is required at the appliance inlet pressure test point.

NOTE:- The inlet Pressure test point is located on the gas valve (Refer to Fig. 13)

Table 2 (Refer to Fig. 1)

SPECIFICATIONS	
CENTRAL HEATING FLOW	22 mm COPPER
CENTRAL HEATING RETURN	22 mm COPPER
COLD WATER MAINS INLET	15 mm COPPER
DOMESTIC HOT WATER OUTLET	15 mm COPPER
GAS INLET	22 mm COPPER
SAFETY VALVE	15 mm COPPER
HEIGHT TO TOP OF JACKET	700 mm (27.6 in)
HEIGHT OVERALL	840 mm (33.5 in)
WIDTH	520 mm (20.5 in)
DEPTH	350 mm (13.8 in)
WEIGHT	38.5 kg (85 lbs)
PRIMARY CAPACITY	2.7 Litres (0.59 galls)
BURNER	OCEAN. 15 REMOVABLE BLADES WITH INDIVIDUAL INJECTORS
MAIN INJECTORS	OCEAN. 15 N° x 1.18 mm
PILOT INJECTOR	SIT 0.27 mod 0.140
IGNITION	PIEZO SPARK
CONTROLS AND IGNITION COMPONENTS	SEE SECTION 7 - SHORT PARTS LIST
MAXIMUM GAS CONSUMPTION	2.69 m <sup>3</sup> /h (95.12 ft <sup>3</sup> /h)
INTEGRAL EXPANSION TANK CAPACITY	7 Litres (1.5 gal) PRECHARGED TO 0.5 bar (7.3 psi)
MAINS SUPPLY VOLTAGE	240 V ~ 50 Hz FUSED AT 3 A
MAXIMUM POWER CONSUMPTION	135 W
MAXIMUM WATER PRESSURE IN HEATING CIRCUIT	3 bar (43.5 psi)
MAXIMUM CENTRAL HEATING FLOW TEMPERATURE	85°C (185°F) APPROXIMATELY *
MAXIMUM INLET DOMESTIC HOT WATER PRESSURE	8 bar (116 psi)
MINIMUM INLET DOMESTIC HOT WATER PRESSURE	0.8 bar (11.6 psi)
MINIMUM FLOW RATE OF DOMESTIC HOT WATER	3 l/min (0.66 gpm)
DOMESTIC HOT WATER FLOW RATE AT 45°C AND 10°C INLET WATER TEMPERATURE (35 °C RISE)	9.6 l/min (2.1 gpm)
MINIMUM FLOW RATE REQUIRED THROUGH BOILER CIRCULATING PUMP	9.86 l/min (2.17 gpm) HEATING MODE EURAMO GOLDSTAR/GRUNDFOS 15/60

\* The boiler control thermostat is intended to operate at a nominal maximum boiler flow temperature of 85°C (185°F)

Table 3

AVAILABLE PUMP HEADS FOR HEATING SYSTEM						PRESSURE LOSS THROUGH BOILER FLOW-RETURN CONNECTIONS	
HEATING OUTPUT		HEADS		MINIMUM SYSTEM FLOW RATE			
kW	(Btu/h)	METRES	(FEET)	LITRES/MIN.	(GALL/MIN.)	METRES	(FEET)
17.6	60,000	2.3	7.4	14.3	3.10	3.25	10.7
16.1	55,000	2.6	8.4	13.57	2.99	2.87	9.4
*14.6	48,000	2.9	9.3	12.31	2.71	2.35	7.7
11.7	40,000	3.5	11.3	9.86	2.17	1.90	5.9

\* FACTORY PRESET

NOTE:- THE INFORMATION CONTAINED IN TABLE 4 IS BASED ON AN 17°C (30.6°F) SYSTEM DESIGN TEMPERATURE DIFFERENCE. THE MINIMUM REQUIRED FLOW RATE THROUGH THE BOILER IS 9.86 L/MIN (2.17 GPM)

# INSTALLATION INSTRUCTIONS

## Installation Warning

Care should be taken to ensure no foreign matter is left in either the gas or water pipework as they could cause damage to the appliance.

## 1 Gas Supply

The local Gas Region should be consulted, at the installation planning stage, in order to establish the availability of an adequate supply of gas.

An existing service pipe **MUST NOT** be used without prior consultation with the Local Gas Region.

A gas meter can only be connected by the Local Gas Region, or by a Local Gas Region Contractor.

An existing meter should be checked, preferably by the Gas Region, to ensure the meter is adequate to deal with the rate of gas supply required.

The boiler requires 2.69 m<sup>3</sup>/h (95.12 ft<sup>3</sup>/h) of gas. The gas meter and supply pipes shall be capable of supplying this quantity of gas in addition to the demand from other appliances being served by it.

Under no circumstances should the gas supply be less than the appliance gas inlet connection (22 mm dia.).

The meter outlet governor should ensure a nominal dynamic pressure of 20 mbar (8 in. wg). The complete installation including the meter must be tested for gas soundness and purged in accordance with the recommendations made in BS.6891.

**NOTE:-** Both the user and the manufacturer rely upon the installer, whose job is to install the boiler and connect it to a correctly designed heating system. **THE INSTALLER SHOULD ACQUAINT HIMSELF WITH THE CONTENTS OF THIS PUBLICATION AND THE RELEVANT BRITISH STANDARDS CONCERNING INSTALLATION REQUIREMENTS.**

## 2 Location of Boiler

In siting the combination boiler, the following limitations **MUST** be observed:

**1** The position selected for installation should be within the building, unless otherwise protected by a suitable enclosure, and **MUST** allow adequate space for installation, servicing and operation of the combination boiler, and for air circulation around it. Refer to Section 2.8.

The boiler is not suitable for external installation.

**2** This position **MUST** also allow for a suitable flue termination to be made. The combination boiler must be installed on a flat vertical wall which is capable of supporting the weight of the combination boiler, and any ancillary equipment.

**3** If the combination boiler is to be fitted in a timber framed building it should be fitted in accordance with the British Gas publication *Guide for Gas Installations in Timber Frame Housing*, Reference DM2. If in doubt, advice must be sought from the Local Gas Region of British Gas.

**4** The combination boiler must not be installed in a bathroom, shower room, bedroom or bed-sitting room.

**5** Garage installations. When planning the installation of a boiler in

a garage, particular attention should be given to the requirements of local by-laws, fire authorities and insurance companies. Where these permit such installations.

**6** A compartment used to enclose the combination boiler **MUST** be designed and constructed specifically for this purpose. An existing cupboard, or compartment, may be used provided it is modified accordingly.

**7** Where installation will be in an unusual location, special procedures may be necessary. BS. 6798: gives detailed guidance on this aspect.

**8** The following clearances shall be made available for installation and servicing.

### INSTALLATION

Above 270 mm (10.6 in) **MINIMUM - SEE NOTE**

In front 450 mm (18 in)

Below - **SEE NOTE**

Side - **SEE NOTE**

**NOTES:-** Site conditions vary and the installer should ensure there is adequate space above and at the sides of the appliance, before commencing the installation.

Clearance below the boiler requires

a) above worktop 270mm (10.6")

b) from floor level 1000mm (39")

### SERVICING AND OPERATION

Above 270 mm (10.6 in)

In front 450 mm (18 in)

Below 1 meter (3.28 ft)

Left hand side 30 mm (1.2 in)

Right hand side 30 mm (1.2 in)

## 3 Flue Position

See Guide to Flue Terminal Positions (Fig.2)

**IMPORTANT:-** The flue system shall be installed in accordance with the recommendations contained in BS 5440:1.

**1** The minimum internal diameter of the flue shall be no less than 125mm (5 inches) and its construction to be in accordance with B.S. 567, B.S. 715, B.S. 835.

**2** The flue shall rise continuously from the boiler and any bends used should not be less than a 135° angle.

**3** It shall be adequately supported throughout its entire length.

**4** 90° bends and horizontal flues should be avoided and the flue should terminate with an approved terminal in accordance with the relevant recommendations given in BS 5440:1.

**5** Existing chimneys may be suitable, but these must be firstly thoroughly swept and then lined with an approved flue liner. If in doubt as to suitability, consult your local British Gas office for advice.

**6** Internal flues through bedrooms, airing cupboards should be protected with a non-combustible material.

**7** Flues through ceilings should be lined with a non-combustible sleeve with a minimum 25mm (1 in) air gap between sleeve and flue.

**8** The flue connection socket fitted to the top of the boiler will accept a normal 125mm (5 inch) metal flue pipe.

## 4 Air Supply

Air for combustion and ventilation must be provided in accordance with BS 5440:2. The appliance should not be installed in a room containing a bath or shower, bedrooms and bed sitting rooms.

1 If the appliance is installed in a room, the room must have a permanent air vent with a minimum effective area no less than 104 cm<sup>2</sup> (16 in<sup>2</sup>). This air vent should be direct to outside air.

2 If the appliance is to be installed in a cupboard or compartment, permanent air vents are required in the cupboard or compartment at high and low level. Both air vents must either communicate to a ventilated room or must both be on the same wall to outside air.

3 Where the cupboard or compartment is ventilated to a room, this room must itself have an air vent to outside air with a minimum effective area of 104 cm<sup>2</sup> (16 in<sup>2</sup>).

Details of cupboard or compartment design, including airing cupboard installation are given in BS 6798.

4 A flue spillage test as detailed in BS 5440:1 must be carried out and any remedial action taken to ensure the installation meets these standard.

5 If an extract fan is fitted within the premises then added ventilation will be required to prevent flue spillage. Details of this test are detailed in BS 5440:1.

**Table 5** FOR BOILER  
IN CUPBOARD/COMPARTMENT

Position of air vent	Air from room/ internal space		Air direct from outside	
	cm. <sup>2</sup>	(in. <sup>2</sup> )	cm. <sup>2</sup>	(in. <sup>2</sup> )
HIGH LEVEL	393	(61)	134	(21)
LOW LEVEL	535	(83)	267	(41)

**NOTE**

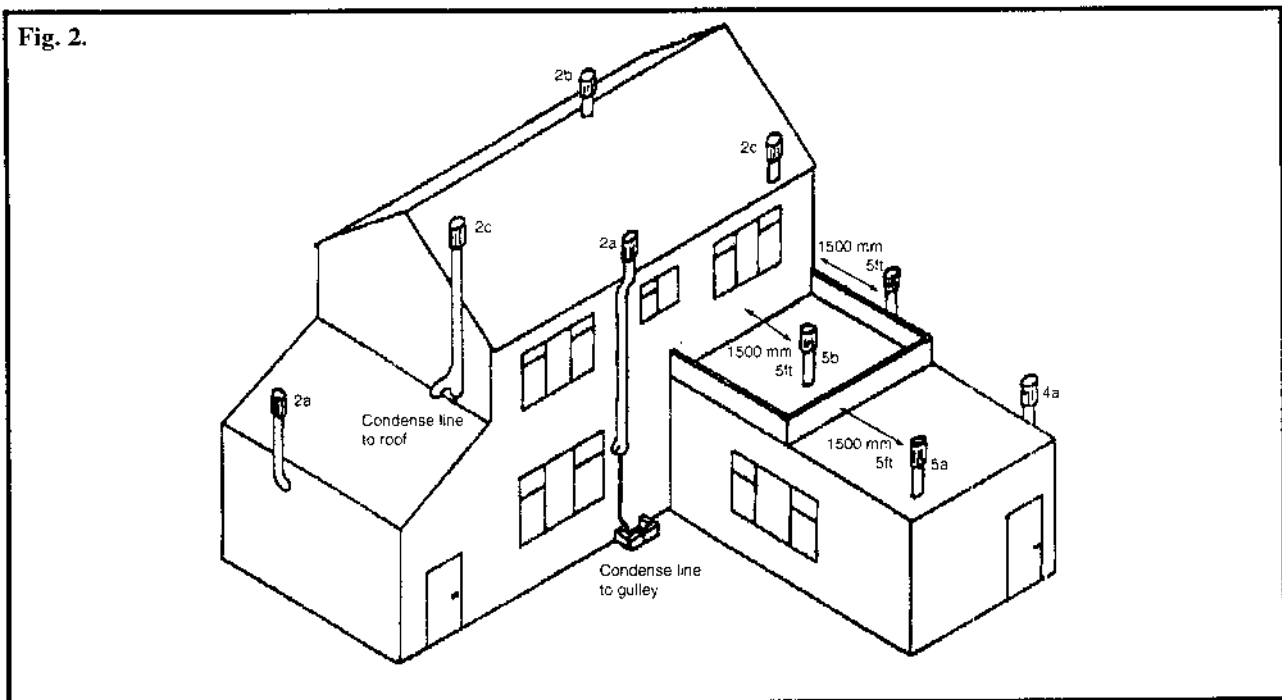
Both air vents **MUST** communicate with the same room or internal space, or **MUST** both be on the same wall to outside air.

**WARNING**

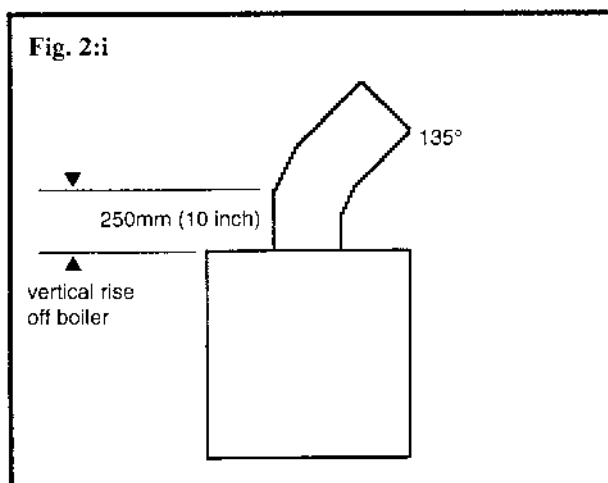
It is important in respect of gas safety that 90° bends should not be fitted to the boiler.

See Fig 2:i and Fig 2:ii.

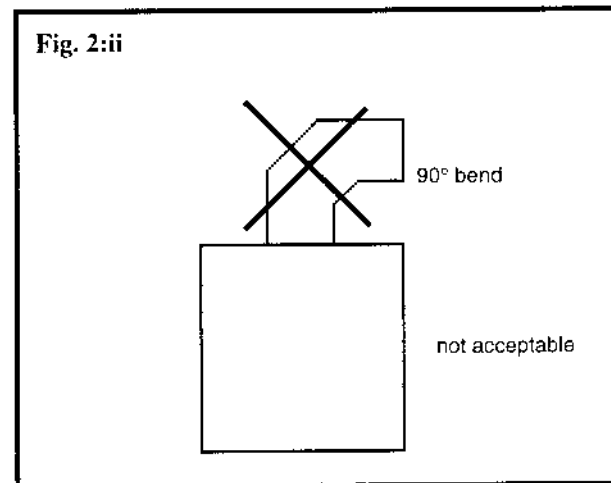
**Fig. 2.**



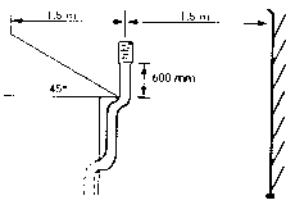
**Fig. 2:i**



**Fig. 2:ii**

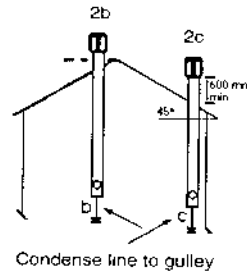


2a



Above eaves. Terminal must be at least 600 mm above eaves and at least 1.5 m (measured horizontally) from any higher vertical surface. If the roof pitch angle is greater than 45° then the vertical rise of flue above the eaves must be increased to 1000 mm.

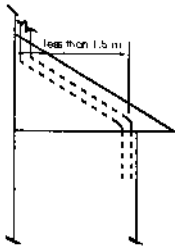
2b - 2c



CONDENSE LINE TO GULLY

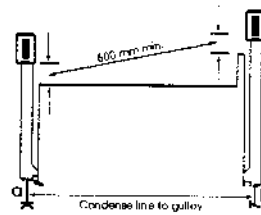
b) At or above ridge level.  
c) Below ridge level. Terminal must be at least 600 mm above intersection of flue and roof and at least 1.5 m (measured horizontally) from any higher vertical surface. If the roof pitch angle is greater than 45° then the vertical rise of flue above the roof line must be increased to 1000 mm (2c).

EXAMPLE OF ALTERNATIVE ARRANGEMENT OF INSTALLATION



When it is not possible to clear a vertical surface by 1.5 m, it may be practicable to run flue through roofspace and then up the vertical surface. (Not detailed on the main drawings).

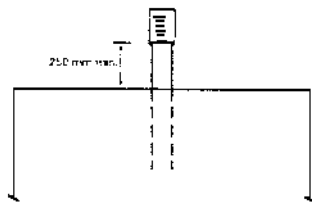
3a



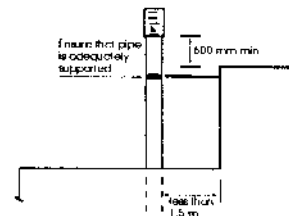
4a

4a) At least 600 mm above unobstructed flat roof.  
3a) At least 250 mm above parapet or similar obstruction and a minimum of 1.5 m (measured horizontally) from any vertical surface

5a

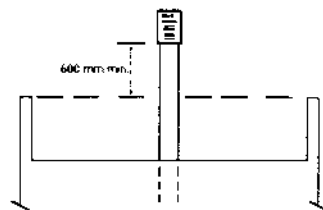


a) On obstruction flat roof terminal must be at least 250 mm above roof and at least 1.5 m (measured horizontally) from any higher vertical surface

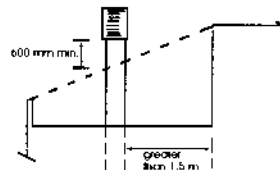


b) Flue less than 1.5 m from vertical surface of structure terminal must be at least 600 mm above top of structure.

5b



c) Flat room with parapet, terminal must be at least 600 mm above intersection of flue and top of parapet. (See also main house drawing).



d) Flue greater than 1.5 m from vertical surface of structure, terminal must be at least 600 mm above a line joining the highest points of neighbouring obstacles.

# REQUIREMENTS FOR SEALED SYSTEMS

## 1 General

The appliance is suitable for sealed central heating systems only. **IMPORTANT:- SEALED SYSTEMS MAY BE FILLED, COMMISSIONED OR DRAINED BY A COMPETENT PERSON ONLY.** The installation shall comply with the recommendations made in BS 6798 and BS 5449:1. Refer to Table 2 for information relating to flow and return pipework.

When designing the heating system refer to Table 3 - page 4. Consider the output requirements of the heating system under consideration - **MAXIMUM 17.6 kW (60,000 Btu/h)** - and note the pump head available. (Table 3) Note the required minimum system flow rate which is based on an 17 °C temperature difference across the HEATING SYSTEM flow and return.

If the system is to operate efficiently the available pump head should not be exceeded or heat output from the radiators may not reach full output under cold weather conditions.

**A MINIMUM FLOW RATE THROUGH THE BOILER OF 9.86 L / MIN (2.17 gpm) IS REQUIRED IRRESPECTIVE OF HEATING LOAD.** Note that requirement will be satisfied at all heating loads of 11.7 kW (40,000 Btu/h) and above, provided the correct system temperature difference of 17°C (30.6°F) is achieved at all times.

A suitable bypass should be fitted and set to achieve the minimum flow rate. Refer to Table 3 and Fig. 3.

The boiler will provide domestic hot water virtually instantaneously at its outlet. However the time taken for hot water to reach any particularly draw off point will depend upon the length of service pipework.

During domestic hot water draw off the central heating service is switched off automatically and is switched on automatically after draw off, providing the controls are calling for heat.

The boiler contains an integral circulating pump. A separate heating pump is not required.

All external heating controls **MUST** be suitable for mains voltage application. Refer to Requirements for Electrical Wiring, Section 3 (Fig. 5).

## 2 Pressure Gauge

The appliance is fitted with a suitable pressure gauge - range 0-4 bar. The gauge is connected via a capillary tube to the heating return pipe on the suction side of the internal pump.

## 3 Safety Valve

The boiler is fitted with a spring loaded safety valve set to operate at 3 bar (45 psi). Refer to Fig. 1, page 3.

A suitable copper discharge pipe 15 mm minimum diameter **MUST** be fitted so that any discharge is directed away from the appliance. The pipe shall terminate such that any discharge from it causes no hazard either to persons, property or electrical installations within or outside the appliance casing.

**IMPORTANT:-** The operation of the safety valve **MUST** be checked during the initial commissioning of the appliance and any subsequent commissioning following servicing of the appliance.

Note:- The period between services should **NOT EXCEED TWELVE MONTHS.**

## 4 Pump

**DO NOT MOVE THE PUMP SETTING FROM MAXIMUM.** A reduction in pump setting will reduce domestic hot water output and may reduce central heating output from radiators.

## 5 Expansion Vessel

The expansion vessel fitted to the boiler is of the diaphragm type, precharged to 0.5 bar (7.3 psi) with a capacity of 7 litres (1.54 gal). The system static head, ie the vertical distance measured from the top of the boiler to the highest point of the system plus 550 mm (22 in) **MUST** not exceed the initial charge pressure of 0.5 bar (7.3 psi), equivalent to 5m (17 ft) of static head.

When the system static head exceeds 5 m (17 ft) the expansion vessel pressure should be increased. Refer to Table 6.

The top of the expansion vessel is fitted with a schraider valve to facilitate increasing the precharge pressure.

## 6 System Volume

The system volume that can be accommodated by the appliance integral pressure vessel depends upon the initial charge pressure and the amount by which the system is pressurised.

Table 6 provides information on the maximum system volume the appliance pressure vessel can sustain under differing design conditions.

If the system design provides for conditions outside the capacity of the appliance pressure vessel, an additional vessel can be fitted. The connection of the additional vessel should be made to the heating system primary return pipe as close to the appliance as possible.

Ensure the total capacity of both vessels is adequate for the system and take note of the recommendations made in BS 5449:1 and BS 6798:1987

**Table 6 BASED ON 3.0 BAR SAFETY VALVE SETTING**

Vessel charge and initial system pressure	bar psi	0.5 7.3	1.0 14.5	1.5 21.8
Total water content of system using 7l (1.54 gal) capacity expansion vessel supplied with appliance	l gal	87	64	44
For systems having a larger capacity MULTIPLY the TOTAL system capacity in litres (gallons) by the factor to obtain the TOTAL MINIMUM expansion vessel capacity required litres (gallons)		.0833	.109	.156

**NOTE:-** When the boiler is operating at maximum operating temperature, providing heating with all radiators operating, the pressure gauge should not indicate more than 2.5 bar (36 psi). If the reading exceeds this figure an additional expansion vessel is required.

## 7 Filling and Venting the System

Before connecting the appliance to the primary domestic hot water system ensure the boiler and system pipework are thoroughly flushed out.

An automatic air vent is fitted to the top of the appliance domestic hot water heat exchanger. Refer Fig. 1.

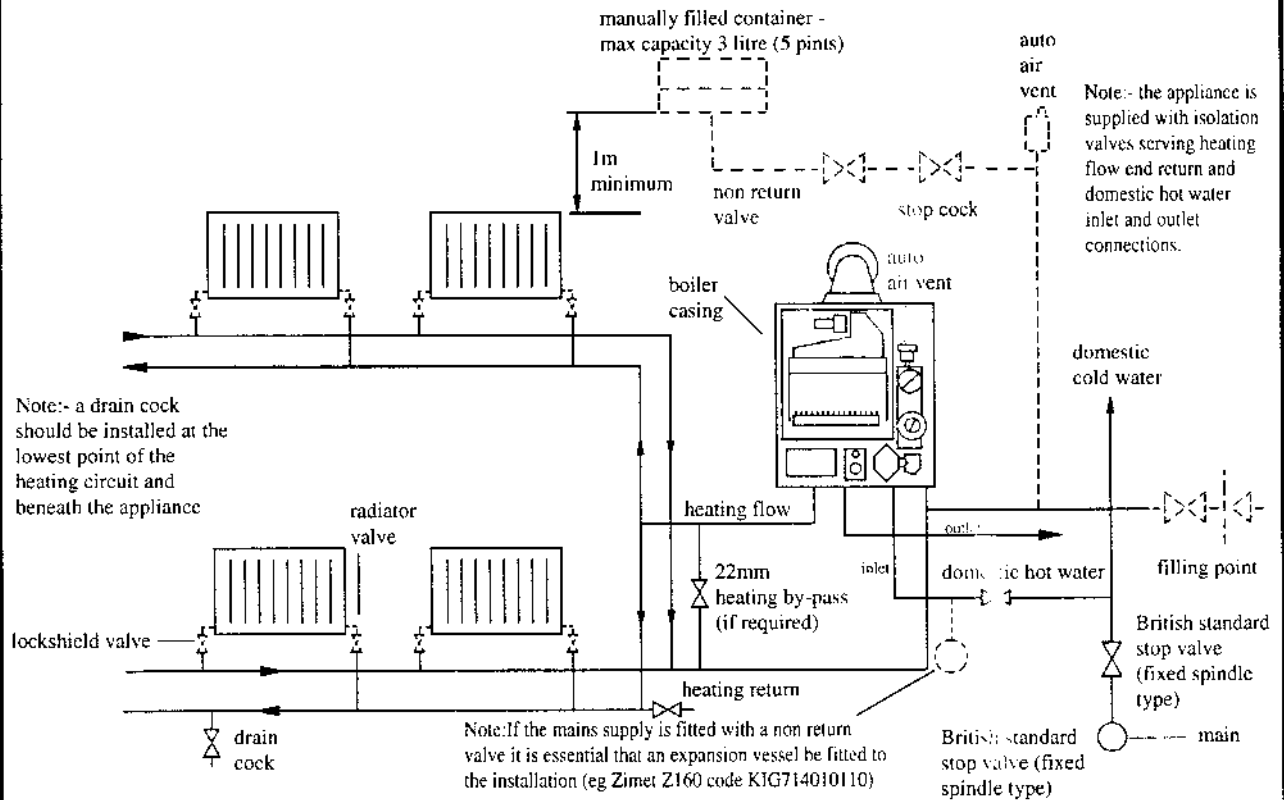
Prior to filling the cap should be opened so that air can discharge freely.

There are two methods of filling the system shown in this literature. Both methods comply with the recommendations made in BS 6798:1987. Refer to Fig. 3.

**NOTE:-** The local Water Undertaking **MUST** approve ALL methods of filling sealed systems.

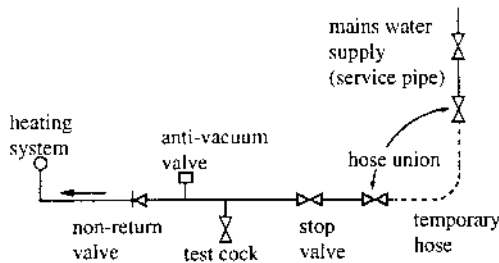
**Fig. 3 SEALED PRIMARY DHW AND HEATING SYSTEM DESIGN CONSIDERATIONS.**

Note:- The appliance is designed for a maximum mains water supply pressure of 8 bar. Don't use a higher pressure. If necessary fit a water pressure reducing valve to ensure design pressure is not exceeded.

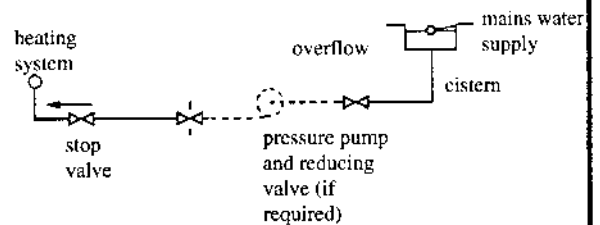


**ALTERNATIVE METHODS OF FILLING SYSTEM**

**METHOD 1. (complies with BS 6798:1987)**



**METHOD 2. (complies with BS 6798:1987)**



**NOTES**

1. When it is not possible to avoid a situation where the initial system pressure and static head are equal a manually fitted top up container should be fitted as shown above. Take note of the requirements relative to container capacity; height above system, inclusion of a non-return valve, stop cock and automatic air vent in the feed pipe. Note also the feed pipe connection is made to the heating return as close to the appliance as possible.
2. The local Water Undertaking MUST approve ALL connections between the system and a water storage cistern or water main supplying domestic hot water.

**8 System Checks**

Existing systems must be thoroughly cleaned using a suitable chemical cleaner.  
 Ensure the system is thoroughly flushed out with cold water prior to filling up to 1.5 bar (21.8 psi) (green area). Clear all air and check for water soundness.  
 Reduce the pressure until the initial design pressure for the system

is obtained. Check the operation of the safety valve at this time. Ensure it discharges in a safe area. Refer Section 3- page 8. The initial system pressure should not exceed 1.5 bar (21.8 psi) (green area).  
 After the boiler has been commissioned and the system brought up to maximum design temperature check for water soundness. While the system remains hot turn off the appliance and drain off all water. Refill the system and vent it. Reset the initial system pressure.

# DOMESTIC HOT WATER SUPPLY TO THE BOILER AND OTHER APPLIANCES

## 1 General

The following information is for guidance only. Contact the local Water Undertaking for specific information and requirements before fitting the appliances referred to below.

The appliance is intended for connection to a mains water supply at a maximum pressure of 8 bar (116 psi). DO NOT use at a higher mains pressure. If necessary fit a water pressure reducing valve. When connecting the mains cold water pipe to the appliance ensure the final 600 mm (2 ft) length is copper.

A maximum domestic hot water flow restrictor limiting the flow rate to 10 l/min (2.2 gal/min) is fitted to the boiler. Higher flow rates will not be harmful to the appliance but may reduce water temperature to an unacceptable level.

Note:- The following appliances have basic requirements for installation:

## 2 Bidets

No anti-syphonage arrangements are necessary provided the outlets are shrouded and it is not possible to attach a temporary hand held spray. A supply of direct mains fed hot and cold water is permitted provided the appliance is of the over-rim flushing type.

## 3 Showers

Fixed head showers require no anti-syphonage arrangements. Loose head showers require an anti-syphonage device to be fitted if it is possible for the heads of the shower to become immersed in bath water.

Alternatively the length of flexible hose shall be fixed so that it is impossible for the shower head to fall closer than 13 mm (0.5 in) to the top edge of the bath. Such an arrangement would avoid the need for an anti-syphonage device.

## 4 Domestic Hot and Cold Water Supply Taps and Mixing Valves

All such devices shall be suitable for use at mains supply pressure.

## 5 Domestic Expansion Vessel

If the domestic system has a check valve installed in the mains water supply to the appliance, then a domestic expansion vessel must be connected to the boiler (ref. Fig. 3 Page 9).

Domestic expansion vessel and connecting pipe reference number KIG714010110 is obtainable from your local merchant stockist or Argos Building and Heating Supplies Ltd. - United House - Goldsel Road - Swanley - Kent - BR8-8EX. Telephone Swanley (0322) 665522.

# REQUIREMENTS FOR ELECTRICAL WIRING

## 1 General Safety

Before any electrical work is undertaken ISOLATE THE APPLIANCE FROM THE MAINS SUPPLY.

If an electrical fault should develop after the appliance has been installed, any electrical fault finding undertaken such as earth continuity, polarity and resistance to earth, MUST be carried out by a competent person.

All external wiring MUST comply with current IEE wiring regulations and any local requirements and health and safety.

THE ELECTRICITY AT WORK REGULATIONS 1989, DOCUMENT N° 635. THE APPLIANCE MUST BE EARTHED.

## 2 Mains Supply Wiring to the Appliance

The appliance should be connected to the mains supply using no less than 0.75 mm<sup>2</sup> (24x0.02 mm) BS 6500 (Table 16) pvc, 3 core insulated cable.

The supply (fused at 3 A) MUST be capable of being isolated from

the appliance using one of the following methods:

a) A three pin plug and unswitched, shuttered socket outlet complying with BS 1363.

b) A double pole isolation switch. The switch contacts MUST have a minimum separation of 3 mm on both poles and MUST supply the boiler and system controls only.

NOTE:- In either case the means of isolation MUST be readily accessible.

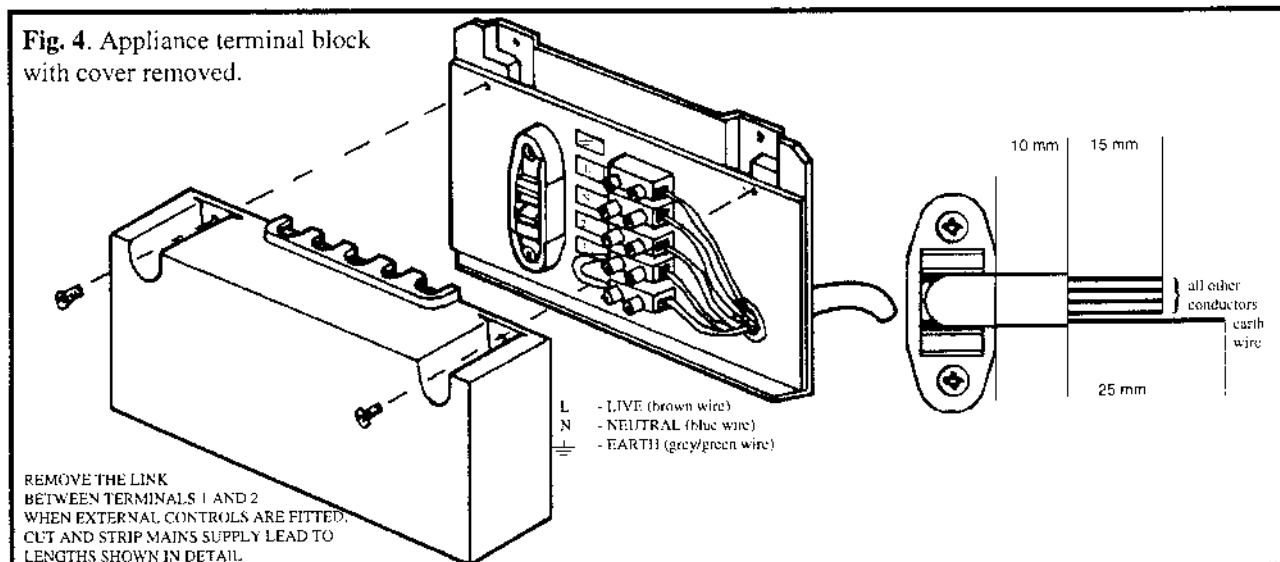
c) The appliance terminal block and cable clamp are protected by a black plastic cover located under the left hand side of the boiler burner assembly.

First remove the white outer casing by unscrewing the two pozipan head screws located on the top, lifting and pulling forward. Release the 3 securing screws and remove the drip tray. The appliance terminal block cover can now be removed to expose the terminals. The cables used to connect the mains electrical supply and external system controls should first be passed through the hole behind the cable clamp.

All cables MUST be clamped securely and routed neatly to the terminal block. Refer to Fig. 4.

THE APPLIANCE MUST BE EARTHED.

After installation carry out electrical safety checks ie. earth continuity, polarity, short circuit and resistance to earth.



### 3 External Wiring of Heating Controls. Clock - Room Thermostat - Frost

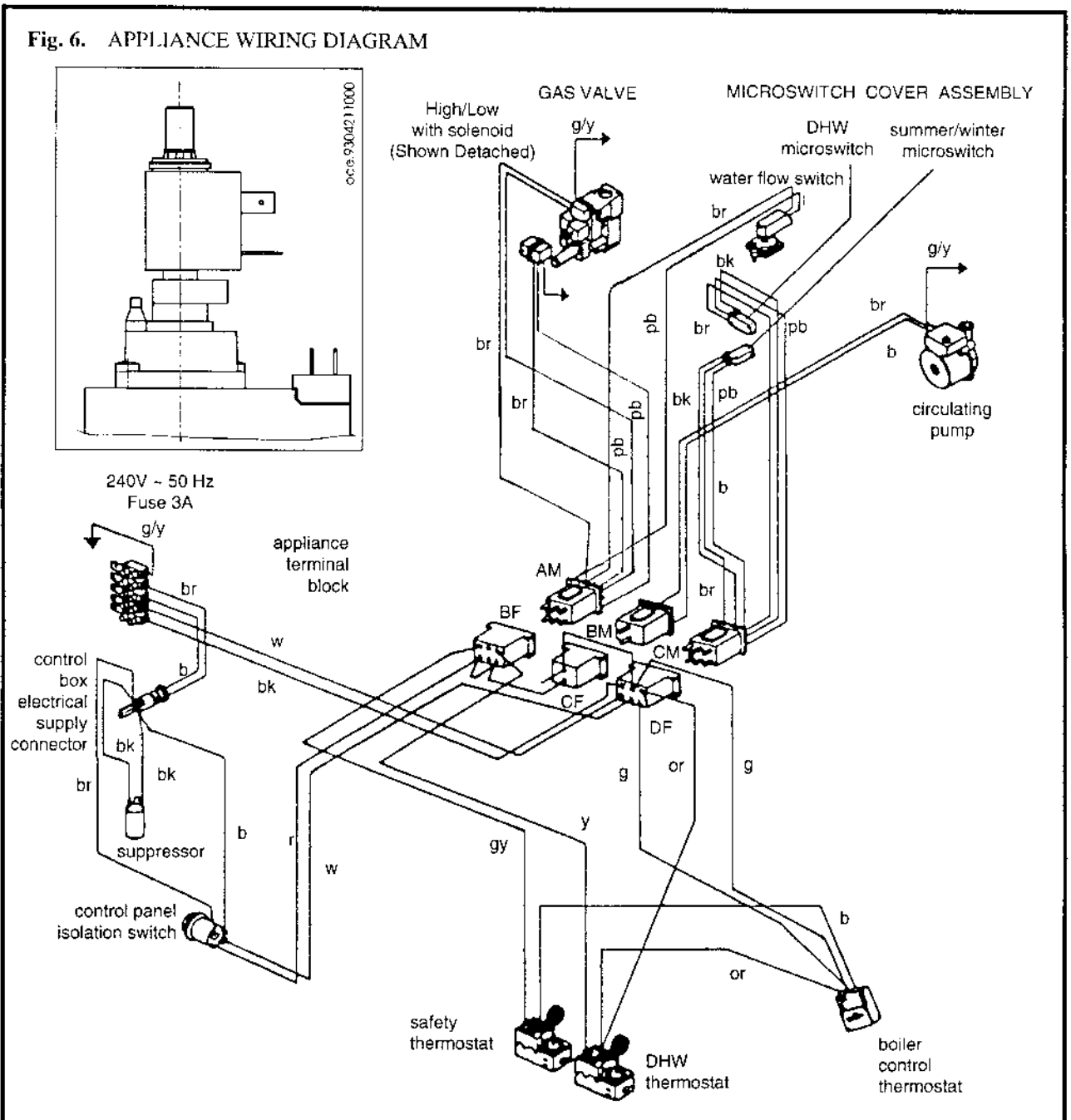
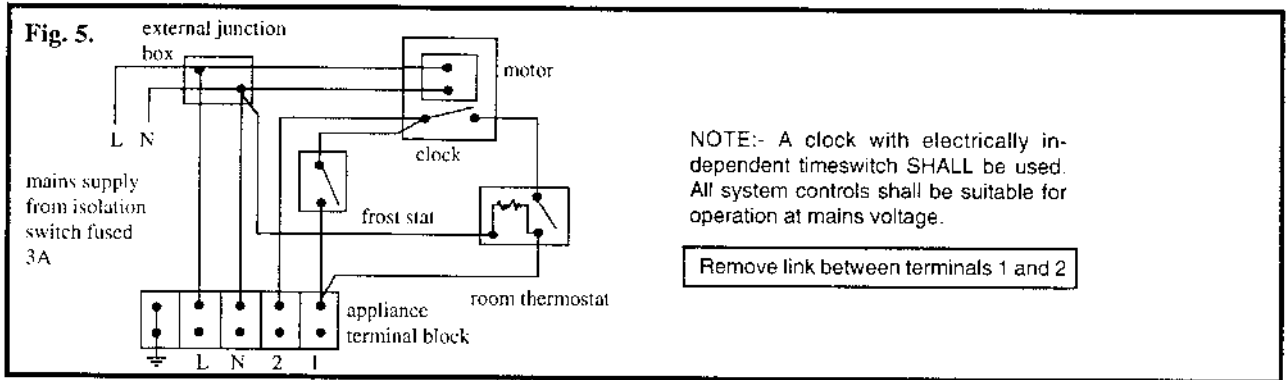
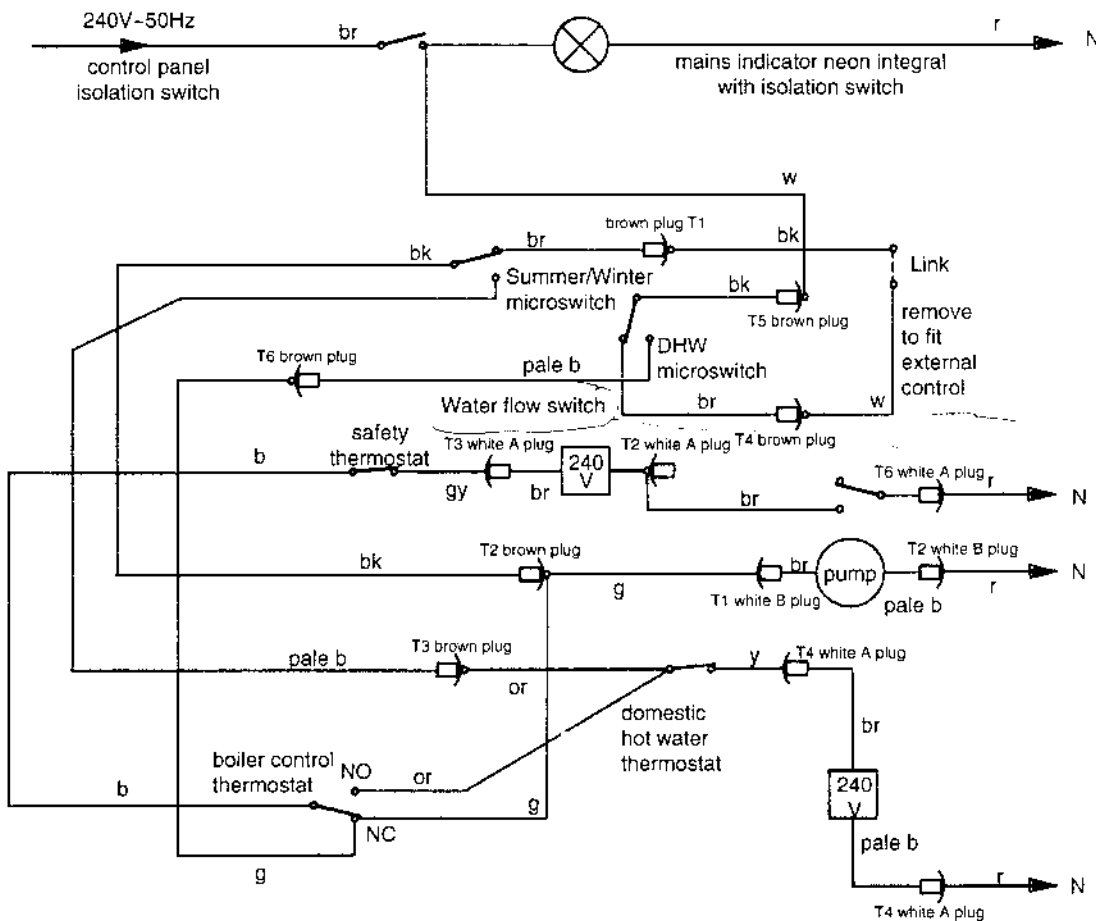
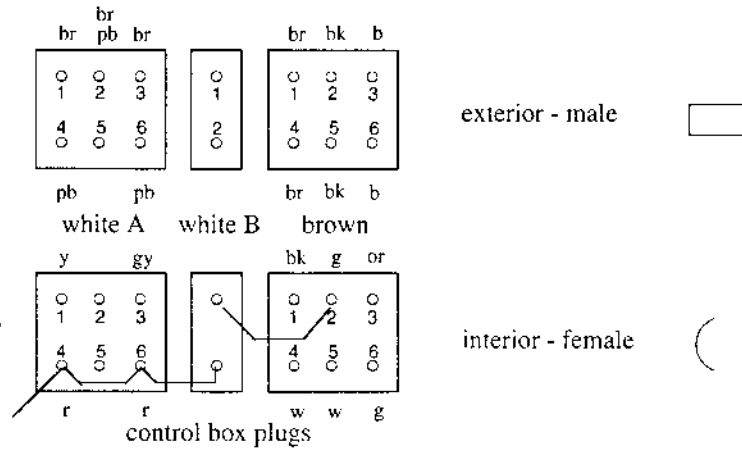


Fig. 7. APPLIANCE FUNCTIONAL FLOW DIAGRAM

Wiring colour codes

b	blue	w	white
bk	black	y	yellow
br	brown	b/bk	blue/black
g	green	b/r	blue/red
gy	grey	w/b	blue/white
or	orange	bk/g	black/green
pk	pink	bk/r	black/red
r	red	w/bk	black/white
v	violet	g/y	green/yellow
pb	pale blue		



# INSTALLATION OF THE APPLIANCE

## Thermostat

### 1 Fixing Templates - Hardware Supplied

Unpack the hardware carton and check its contents against the list below.

ONE Wall mounting plate assembly complete with:

Paper templates;

3/4" heating flow isolation valve and safety valve assembly;

3/4" heating return isolation valve;

1/2" domestic mains inlet isolation valve;

ONE plastic bag containing gas cock with flanges straight pipe section / half union; gas supply union elbow and pipe support clip.

ONE small plastic bag containing 'o' ring seal and two M5 hexagon head fixing screws (Fig. 10).

3 off 3/4"x22mm union elbows; } contained  
2 off 1/2"x15mm elbows. } in plastic bag

TWO small plastic bags containing sealing washers for domestic hot water and heating flow/return connections between wall template and boiler internal pipework;

ONE plastic bag containing:

Wall template-upper cross bar extension (left hand side) with single M4 pozidrive fixing screw;

7 N° 10x45mm long wood screws, plugs and washers.

NOTE:- SIX SETS ONLY NEED BE USED; ONE SET IS SPARE TO REQUIREMENTS.

### 2 Fixing the Wall Mounting Plate

The wall mounting plate is supplied with all necessary fittings and accessories to make water and gas connections to the appliance. The plate **MUST** be mounted on the wall in the position desired for the appliance. The mounting points for the appliance and the fixing holes for the upper and lower cross bars are built into the plate. Refer to Fig. 9, in particular Note 1, and assemble the wall mounting plate upper cross bar. Refer to Fig. 8 and check that all fittings and accessories are correctly mounted.

Using the WALL MOUNTING PLATE mark on the wall to which the appliance is to be fixed the four fixing hole positions.

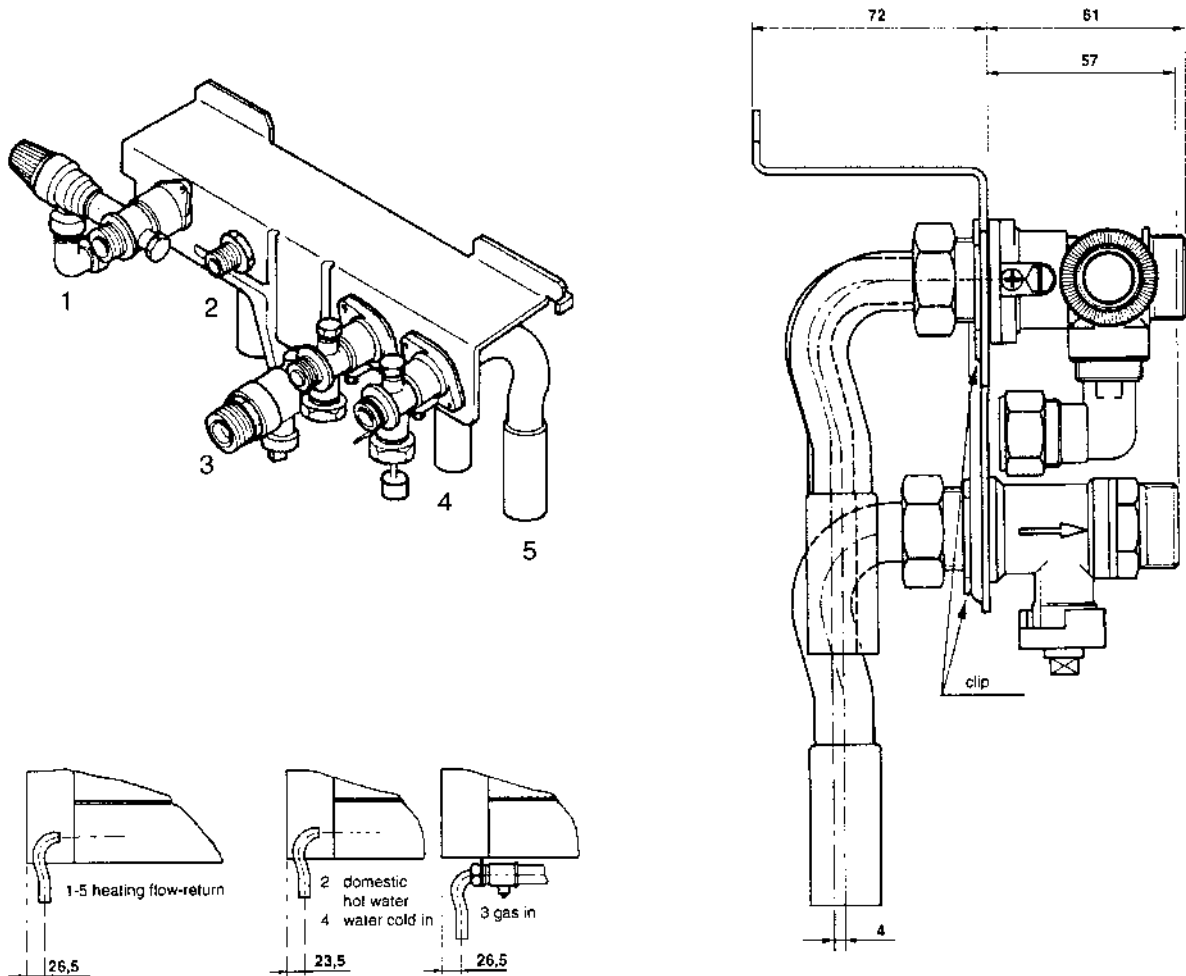
Check the horizontal and vertical levels before proceeding.

Drill the six fixing holes in the wall face using an 8 mm (0.3 in dia.) masonry drill. Fix the upper and lower cross bars to the wall face using the plastic plugs and N° 10 screws provided. Recheck the horizontal and vertical levels.

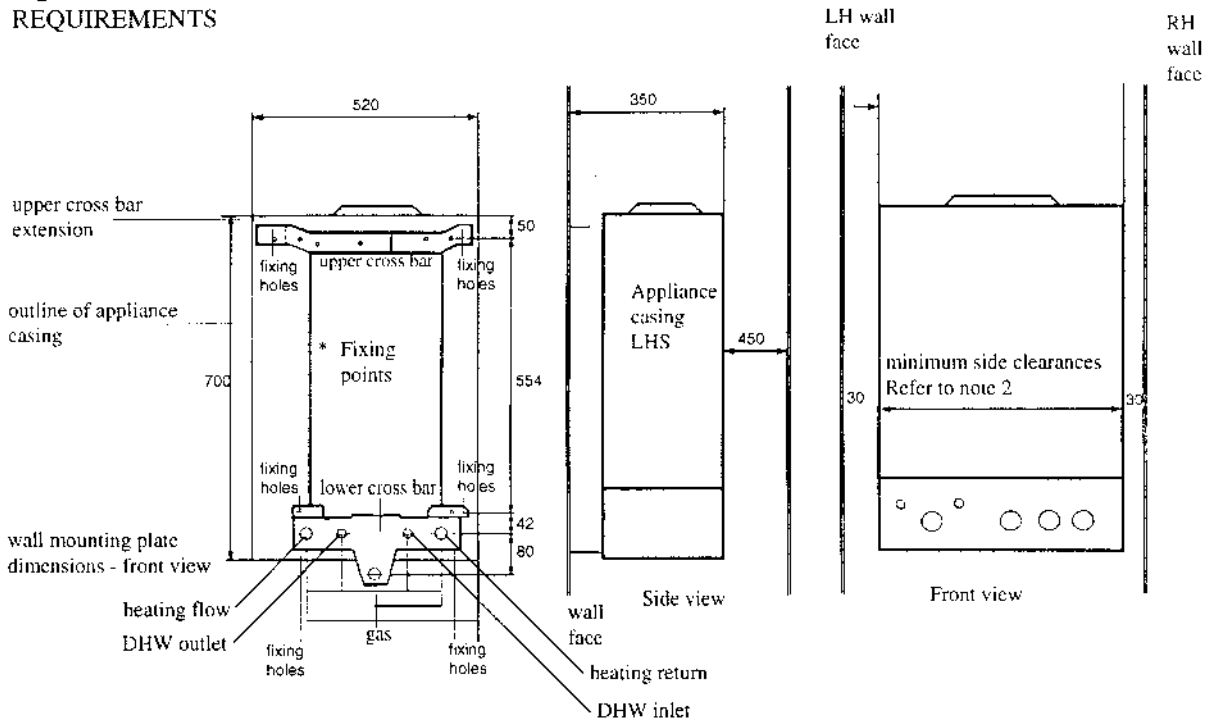
Note:- The acrylic sheet between the upper and lower cross bar should be taut.

Remove all protective caps from fittings on mounting plate. Refer to Fig. 8.

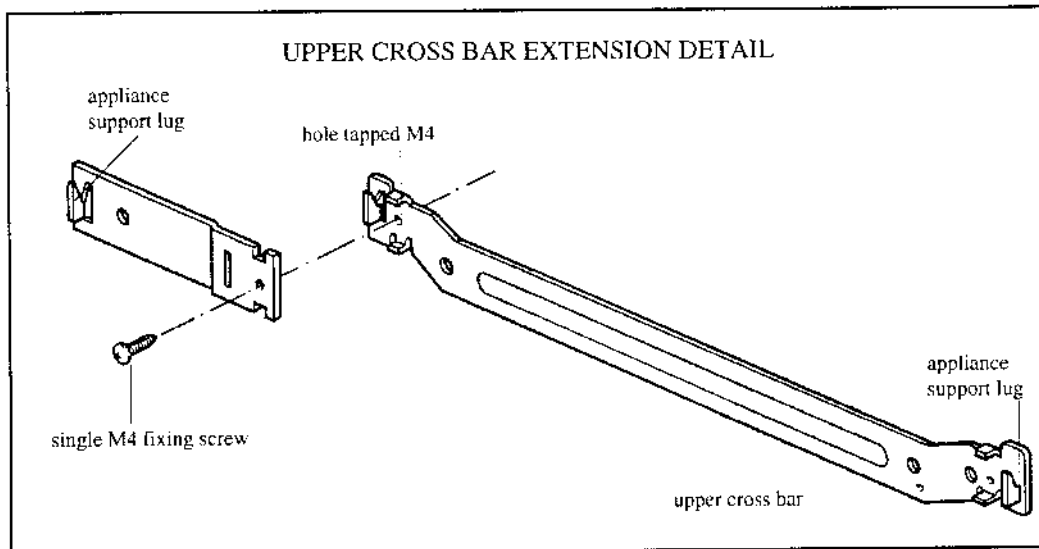
Fig. 8.



**Fig. 9. DIMENSIONAL RELATIONSHIP BETWEEN APPLIANCE AND WALL FACE WALL MOUNTING REQUIREMENTS**



1. The upper cross bar extension is intended to fit the LEFT HAND END of the upper cross bar. The extension fits IN FRONT OF the main bar
  2. The MINIMUM left and right hand side clearances should apply - 30mm - radiated heat sideways.
- Refer to Section 2.8. LOCATION OF BOILER for complete information on required all round clearances.



### 3 Making Service Connections from the System to the Wall Plate

Refer to Fig.8

Remove ALL OF THE POLYTHENE CAPS protecting the screw threads of the fittings mounted on the boiler. The layout of the services and their position is given in Fig. 8. Note that the: HEATING FLOW AND RETURN SOCKETS ARE 22 mm COPPER;

GAS SUPPLY SOCKET IS 22 mm COPPER;

DOMESTIC HOT WATER MAINS INLET SOCKET IS 15 mm COPPER;

DOMESTIC HOT WATER SERVICE OUTLET SOCKET IS 15 mm COPPER.

All are labelled clearly.

The isolation valves for heating flow and return and the domestic service are supplied.

Before the boiler is mounted on the wall plate the water and gas services need to be connected to the back of the wall plate using the union elbows, washers, sockets provided.

Check that all other fixings have been made in accordance with Fig. 8.

Washers are provided in two polythene bags, suitably labelled, to ensure water soundness at each union connection. ENSURE THE WASHERS AND THE GAS COCK 'O' RING SEAL ARE FITTED. THEN REFER TO SECTION 4.

The main gas cock complete with fittings for connection to the appliance is packed in a polythene bag.

When all the external service pipework has been connected to the rear of the wall plate lower cross bar examine the connections made to the boiler. FLUSH THE SYSTEM, and ensure it is completely free of debris, such as flux, solder, etc.

When the boiler has been removed from its packaging to prepare it for mounting onto the wall mounting plate, the white casing needs to be removed. This is retained by a pozipan head screw at the top left and right hand side. Remove the screws and lift off the casing. (a) Remove the guard plate (Fig. 11) by removing the M5 hexagon head screws retaining the left hand end of the panel.

(b) Loosening the M5 hexagon head screws retaining the right hand end of the plate sufficiently to allow the plate to be removed - left hand end first.

### 4 Hanging the Boiler on the Wall Plate and Making Service Connections to the Boiler

NOTE:- A two men lift may be required.

Refer to Fig. 10 and REMOVE THE RED PLASTIC PLUG protecting the gas valve inlet connection.

1 Offer the boiler up to the wall plate and hang it on the TWO projecting support lugs provided at the left and right hand ends of the upper cross bar. Refer Fig. 9. A key hole slot is cut into the return edge of the boiler left and right hand side panels, near the top, for this purpose. The lower cross bar has a centralising lug positioned at the right hand end. ENSURE the slot cut in the return edge of the right hand rear side panel, near the bottom, is engaged with the lug.

2 Before proceeding further ENSURE all lugs are securely engaged and the appliance is firmly in position. Check horizontal and vertical levels.

3 IMPORTANT. Identify the small polythene bag containing the 'o' ring seal for the main gas supply pipe. Packed also in the small bag are two M5 hexagon head fixing screws for attaching the gas supply pipe outlet flange to the boiler gas valve inlet and ensuring a gas tight seal. Refer to Fig. 10 and 11. Fit the gas cock and pipe assembly to the wall plate lower cross bar by making good the union connection.

Using the two M5 hexagon head screws and O-ring seal provided fix tightly the flange of the gas supply pipe to the gas valve inlet. THE GAS SUPPLY PIPE 'O' RING SEAL IS IMPORTANT TO THE SAFE OPERATION OF THE APPLIANCE AND MUST NOT BE OMITTED.

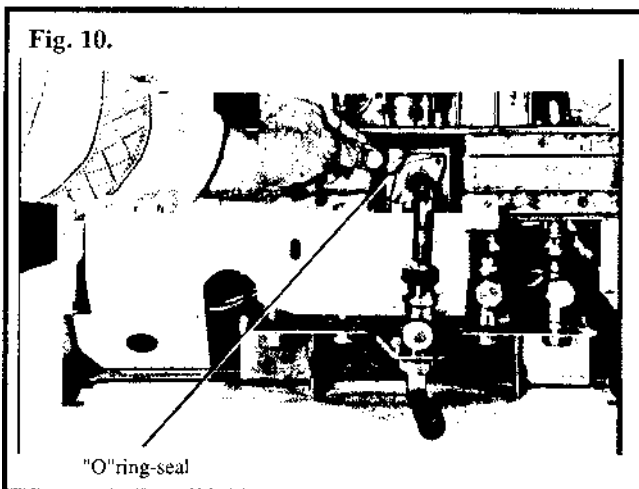
4 Make the boiler connections to the heating flow and return: also the domestic hot water mains inlet and service outlet connections fixed to the wall plate, using the union connections positioned at the ends of the INTERNAL pipework stubs.

Note:- Ensure all four connections are made using a fibre sealing washer. A small polythene bag, labelled, containing all necessary washers is supplied.

5 The safety valve discharge is fitted with a brass elbow having a 15 mm compression fitting pointing to the rear. Ensure a suitably routed 15 mm dia. copper discharge pipe is fitted from the elbow to a safe drain point. The pipe MUST be fitted so that the guard plate (Fig. 11) can be removed for servicing and any steam or liquid will discharge safely i.e. the pipe shall terminate such that any discharge from it causes no hazard either to persons, property or electrical installations within or outside the appliance casing.

Ensure the pipe is routed so that after testing during servicing (section 6.8) it cannot retain water. Insulate the pipe to inhibit freezing during cold weather.

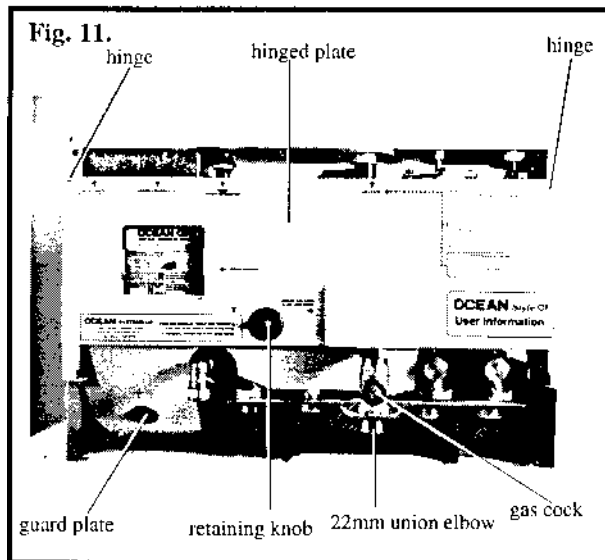
Make all necessary electrical connections to the appliance. Refer to Requirements for Electrical Wiring - Sections 1, 2 and 3.



## 5 Commissioning the Appliance

A.

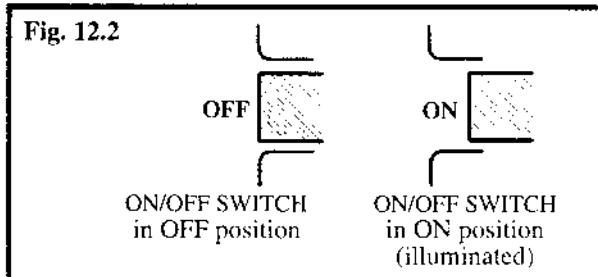
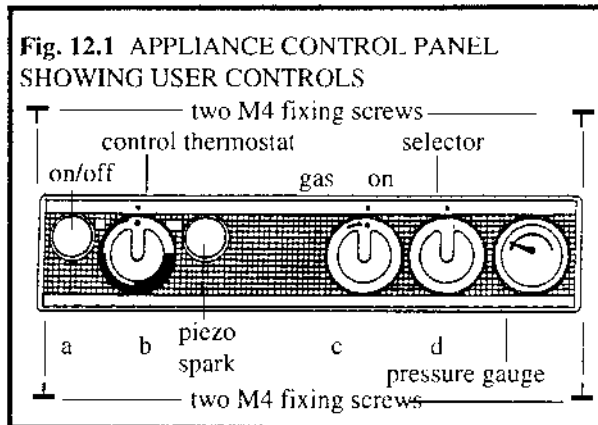
1. The complete gas installation, including the meter **MUST** be purged and tested for gas soundness in accordance with BS 6891:1988.



2. Isolate the electrical supply.
3. Turn off the gas supply at the appliance service cock (Fig. 12.3).
4. Open the central heating flow and return, and the domestic hot water isolation valves (Fig. 8).
5. Loosen the cap of the automatic air vent on the appliance (Fig. 3). Leave it open.
6. Open all radiator valves and system air vents.
7. Fill the system - see REQUIREMENTS FOR SEALED SYSTEMS
8. Check the system for water soundness of the system and appliance.
9. Drain the system, flush, refill and vent. Refill the system to the Initial Design Pressure but do not exceed 1.5 bar.

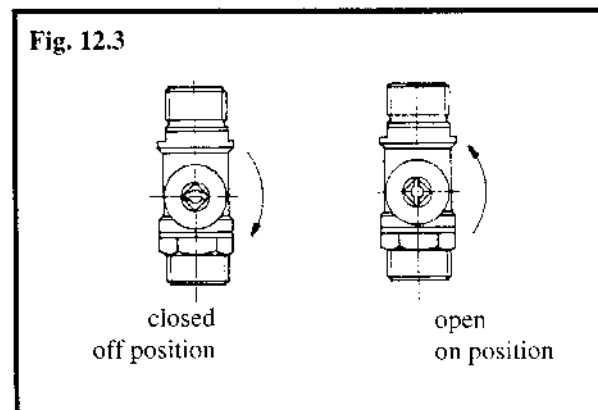
B.

1. Refer to Fig. 12.1.
2. Set the selector to domestic hot water only (H<sub>2</sub>O). Turn on all hot water service taps and allow water to flow until no air is present. Note that taps must be capable of delivering INDIVIDUALLY at least 3 litres/min (0.66 gpm), although a flow rate of 9 to 9.5 litres/min (2 to 2.1 gpm) is recommended. Turn off the taps.
3. If it is wished to check the soundness of the pilot supply, this must be done without the main burner alight. Electricity supply must remain isolated.
  - a) Turn on the gas supply at the gas service cock.
  - b) Fully depress the gas valve knob (Fig. 13.1) and hold in. Allow the pilot pipe to purge then press Piezo spark to light pilot burner.
  - c) When lit, hold in the gas valve knob for a further 20 seconds, then release and the pilot should remain alight. If it goes out, repeat step 3b above.
  - d) Check for gas soundness of the pilot pipe connections using leak detection fluid.
  - e) Check that the pilot flame is correct (Fig. 13.3). If necessary, adjust the length via the pilot adjustment screw (fig. 13.1). Screwing clockwise reduces the flame length.  
Note: The normal thermocouple closed circuit voltage range is 8 mV to 12 mV.
  - f) Leave the pilot alight.
4. Loosen the burner setting pressure test point screw (Fig. 13.1) and attach a pressure gauge. Set any external controls to call for heat.



5. Using a screwdriver, carefully prise off the heating thermostat control knob (Fig. 12.1).
6. Remove the two outer screws revealed (not the inner screws).
7. From underneath and behind, push off the selector knob (Fig. 12.1).
8. Remove the four control panel fascia fixing screws and remove the fascia (Fig. 12.1).
9. Temporarily refit the heating thermostat control and selector knobs.

C. CHECKING/ADJUSTING THE HEAT INPUT / BURNER



PRESSURES.

Note: Adjustments must be made in the order given.  
The maximum Domestic Hot Water input is factory set to 28.9 kW. Although the burner pressure should be checked, adjustment should not be necessary unless the central heating input is changed.  
The Central Heating input is factory set to 17.8 kW, but this can be adjusted to suit the system requirements between the values given in Table 1. The setting must be between 14.9 and 22.06 kW input. It will also be necessary to check that the low setting on Domestic Hot Water (which coincides with the central heating input) can be obtained. Check for spillage according to BS 5440.1:1990.

C.1. DOMESTIC HOT WATER - MAXIMUM INPUT

- a) Selector knob set to Domestic Hot Water Only (H<sub>2</sub>O) (identify from fascia panel).
- b) Hot water tap fully open.
- c) Switch on the electricity supply.

- d) Depress the ON/OFF switch (Fig. 12.2) which will illuminate. If the pilot is alight, the main burner will light. Immediately check that the burner pressure is as given in Table 1 (13.9 mbar).
- e) If adjustment is required, using a 10 mm blade screwdriver, adjust the spindle A, Fig. 13.2 (counter clockwise to decrease). The prescribed pressure must not be exceeded.
- f) Turn the hot water tap off and on a few times and ensure that the pressure indicated remains correct.
- g) Isolate the electrical supply.
- h) Close all hot water taps.
- Note: Any adjustment of spindle A will result in the central heating setting, which has been factory set, being altered.

#### C.2. CENTRAL HEATING - FIXED INPUT

- a) Selector knob set to Domestic Hot Water + central heating (☺☺).
- b) Heating thermostat to maximum.
- c) ON/OFF switch to ON.
- d) System controls calling for heat, all radiator valves, if fitted, fully open.
- e) Switch on the electricity supply. If the pilot is alight, the main burner will light. After about 10 minutes, check the burner pressure.
- f) Adjust the burner pressure to the required value, using a 3.5 mm blade screwdriver, via screw B, Fig. 13.2. **DO NOT ALLOW THE SPINDLE A TO MOVE.**

#### C.3. RECHECKS

- a) Recheck the Maximum Domestic Hot Water Setting as described in C1 above.
- b) Note that each time the Domestic Hot Water setting is adjusted, the central heating setting must be rechecked.

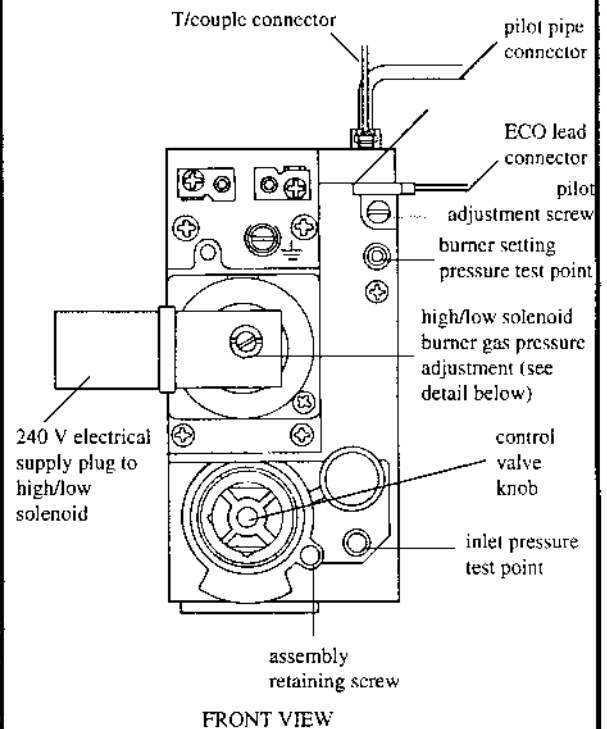
#### C.4. DOMESTIC HOT WATER - MINIMUM INPUT

- a) Isolate the electricity supply.
- b) Remove the plug from the HIGH/LOW solenoid valve (screw, Fig. 13.2). Place safely as the plug will be live for the following check.
- c) Selector knob to Domestic Hot Water Only (☺).
- d) Hot water tap fully open.
- e) Electricity supply on.
- The pressure should be the same as set for Central Heating. Adjustment is not possible - refer to Fault Finding if the setting is incorrect.

#### D. COMPLETION

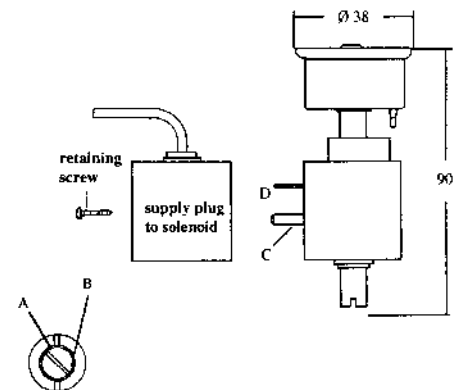
1. Isolate the electricity supply.
2. Refit the HIGH/LOW solenoid valve plug.
3. Remove the pressure gauge and retighten the test point screw, ensuring a gas tight seat.
4. Remove the heating thermostat and selector knobs.
5. Refit the control panel fascia, securing with a total of six screws.
6. Refit the knobs.

**Fig. 13.1. GAS CONTROL VALVE - ADJUSTMENTS**

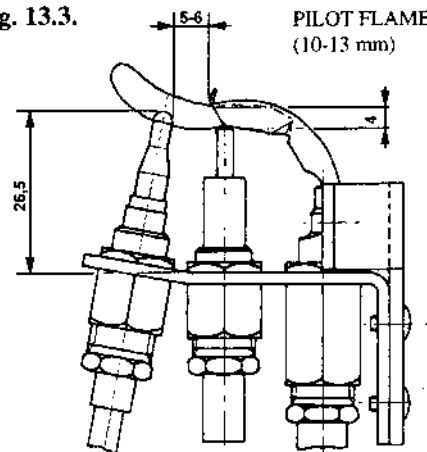


**Fig. 13.2. DETAIL OF HIGH/LOW SOLENOID**

- A:- adjustment screw for maximum pressure setting  
 B:- adjustment screw for minimum pressure setting  
 C:- 6.3 mm amp terminals  
 D:- earth terminal



**Fig. 13.3. PILOT FLAME LENGTH (10-13 mm)**



## 6 Checking Operation of the Central Heating / Domestic Hot Water Services and Safety Valve

1 Set the control thermostat to OFF and the service selector knob to central heating and domestic hot water. Depress and release the ON/OFF button. Turn the control thermostat to maximum; the burner should light and the burner pressure should stabilise at the (LOW) setting after a few minutes.

2 Turn on a tap so that the flow rate is approximately 9 l/min (2 gpm). Use a suitable measuring device to check the flow rate. When the tap is turned on the burner pressure should rise to the (HIGH) gas pressure setting and remain steady.

The water temperature should begin to rise and depending upon the flow rate and cold water inlet temperature settle down to between 40°C and 50°C.

Reduce the rate at which water is drawn off gradually until water temperature rises to between 60°C and 70°C, when the gas pressure should fall from HIGH to LOW and then commence to switch between HIGH and LOW as the water temperature rises and falls. Further reduce the rate of draw off gradually until water temperature rises to between 70°C and 80°C when the burner should switch off, then commence to switch on and off as water temperature rises and falls.

Note:- The minimum domestic hot water draw off rate is 3 l/min (0.66 gpm) below which the appliance will not operate.

Reverse the procedure above and check each stage of operation ie. switching between HIGH/LOW gas pressure at intermediate water flow rates and operation at HIGH gas pressure when flow reaches maximum draw off rate.

3 Set the service selector knob to domestic hot water only. Check that the maximum flow rate can be obtained. When completed turn off the tap when the burner should extinguish.

Turn the tap on and off at 10 seconds intervals two or three times and check burner ignition and shut down.

Turn off the tap. Set the service selector knob to central heating and domestic hot water.

The burner should extinguish and provided the timer and any heating controls are calling for heat the burner will relight at LOW gas pressure setting.

4 Operate the appliance on central heating service and allow the system to warm up. Check the system is heating up evenly and then turn the control thermostatic knob towards its minimum setting. Observe the burner to extinguish. Turn the thermostat knob towards its maximum setting when the burner should relight. Repeat the procedure once more.

5 If the heating system is fitted with thermostatic radiator valves AND A BYPASS then proceed to make the following adjustments. IF A BYPASS IS NOT REQUIRED:

ie. an uncontrolled radiator of minimum catalogue rating 1.2 kW (4,100 Btu/h) is fitted, proceed to Section 6.7 below.

Provided the heating system has been designed to take account of the AVAILABLE PUMP HEAD FOR HEATING SYSTEMS - Table 3 - page 5, the pump energy should ensure a temperature difference across the boiler flow and return pipes of 17 °C (30.6°F) maximum. However, the setting pressure should be matched to maximum heating load when all thermostatically controlled radiator valves are fully open and the BYPASS CLOSED. The central heating system should be heated up from cold under this condition for at least 15 minutes. Ensure any time clock or room thermostat fitted cannot cause the boiler to switch off. When adjusting the bypass it is important to ensure the boiler is firing continuously, as cycling of the boiler control thermostat gives a false impression of the temperature difference.

Using a contact thermometer balance the system if required. If the circulating pump is fitted with a speed adjustment it will be factory preset at maximum. DO NOT ADJUST.

Check the temperature difference across the boiler flow/return pipes (A & B Fig. 14). Provided the available pump head has not been exceeded (refer Table 3) the temperature difference will be below 17 °C (30.6°F).

SEE NOTE BELOW. Check the temperature difference ACROSS THE SYSTEM ie. ACROSS THE FLOW AND RETURN PIPES UPSTREAM OF THE BYPASS (C & D Fig. 14). Open the bypass

lock shield valve slowly until the temperature difference across the system is 17 °C (30.6°F).

NOTE:- If the available pump head has been exceeded the bypass should be left CLOSED.

An uncontrolled radiator of catalogue rating 1.2 kW (4,100 Btu/h) MINIMUM should be chosen from within the system to act as a suitable source of heat dissipation. The appliance should NOT be operated at a flow rate less than 9.86 l/min (2.17 gpm).

7 Balance the system if required.

Check operation of the time switch and room thermostat if fitted. Depress the ON/OFF button and release.

Isolate the appliance at the wall socket or isolation switch. Set any timer and heating controls to OFF. Set the boiler control thermostat to OFF.

Replace the white outer casing using the reverse of the procedure under Section 3.

NOTE:- The two fixing screws provided MUST be refitted.

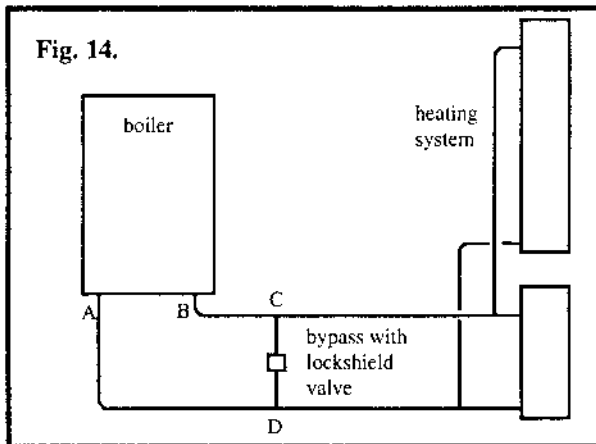
IMPORTANT:- If the factory setting on the central heating gas pressure has been altered during commissioning refer to the data plate, positioned UNDER THE APPLIANCE, FIXED TO THE CONTROLS SUPPORT PLATE.

RESET the indicator arrow, which will be set against the factory preset output of 14.1 kW (48,000 Btu/h). Move the arrow to indicate clearly the revised central heating output.

8 Check the operation of the safety valve. Refer to Fig. 1 and Installation of the Appliance - Section 4.6. Test by turning the safety valve knob anticlockwise half a turn and then releasing, quickly. The valve should discharge and reseat itself without leaking.

9 Replace the guard plate and fit the hinged panel. The hinged panel is supplied separate with its fitting instruction in the main boiler carton.

10 Turn on power at the wall socket or isolation switch. Set the time and heating controls, if fitted, and the service selector knob to the user's requirements. Depress and release the ON/OFF button. Set the boiler control thermostat to MAXIMUM.



## 7 Instructions Provided for the User

Instruct the user or purchaser of the appliance on the correct operation of the appliance and hot water / heating system.

Hand the User Instructions to the user and ensure he/she understands the procedures required to operate the appliance.

Make sure the user is aware of any precautions necessary to avoid damage to the appliance and heating / domestic hot water system and to the building in the event of the appliance and system being in operation during frost conditions.

Advise the user of the need to ensure safe and efficient operation of the appliance and system by regular servicing. The appliance should be serviced by A COMPETENT PERSON AT LEAST ONCE EVERY TWELVE MONTHS, or at intervals recommended by the local Gas Region.

If further advice or assistance is required relating to servicing contact Argos Building and Heating Supplies Ltd.

# SERVICING THE APPLIANCE

## 1 Annual Servicing - Routine Inspection and Cleaning

To ensure continued efficient operation of the appliance it is recommended that it is checked and serviced as necessary at regular intervals. The frequency of servicing will depend upon the particular installation conditions and usage but in general once per year should be adequate. It is the law that any service work MUST be carried out by a competent person such as British Gas or other Corgi registered personnel.

1. The following items should then be cleaned or checked for signs of deterioration before being replaced, if necessary.

a) Note any faults in the operation of the appliance when operated as described under Section 2 below.

b) Examine and clean the pilot burner assembly: pilot injector, spark electrode, thermocouple.

c) Examine and clean the main burner assembly: injector and injector manifold.

d) Observe the condition of the combustion chamber insulation.

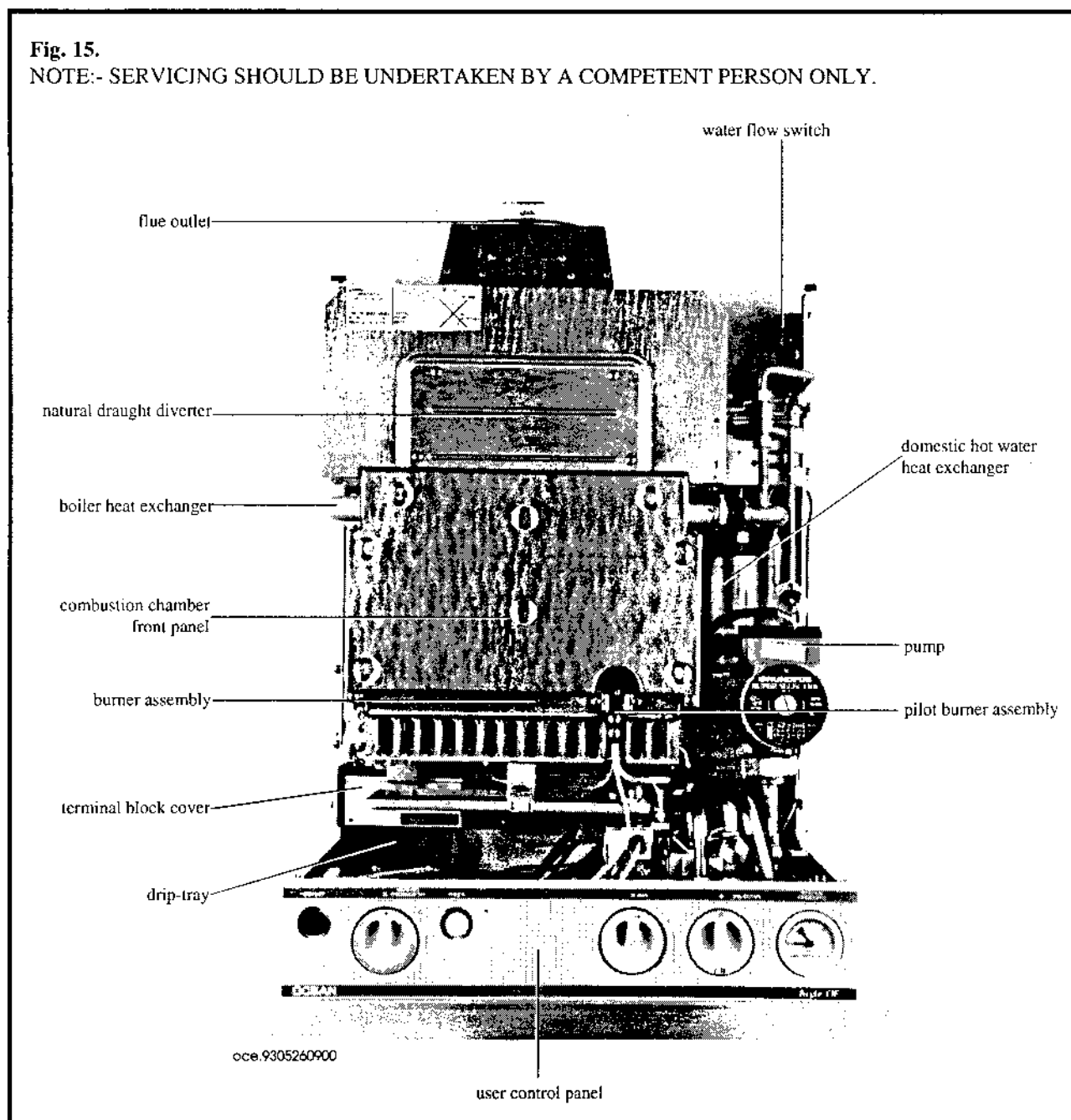
e) Examine and if necessary clean the heat exchanger.

f) Examine the flue system and ensure there is no blockage and that the flue terminal is unobstructed.

When the appliance has been fitted inside a compartment the ventilation areas required should be checked and cleared of any obstruction. If necessary BRING TO THE USER'S ATTENTION THE NEED TO ENSURE the ventilation openings are kept free of obstruction.

Fig. 15.

NOTE:- SERVICING SHOULD BE UNDERTAKEN BY A COMPETENT PERSON ONLY.



## 2 Checks Undertaken Prior to Servicing

a) Remove the white outer casing by unscrewing the pozidrive head screws located on the top left and right hand sides. Lift and pull casing forward.

b) Operate the appliance by undertaking the normal lighting procedure from cold. Follow the instructions on the hinged plate under the boiler. Turn knob quarter turn clockwise to release.

Allow the central heating system to warm up and check both central heating and domestic hot water services. Observe the operation of the boiler and controls. Note any faults which will need to be rectified during servicing.

**IMPORTANT:- ISOLATE THE MAINS ELECTRICAL SUPPLY AT THE WALL SOCKET OR SWITCH BEFORE ATTEMPTING TO SERVICE THE APPLIANCE.**

Note:- There are warning notices attached to the appliance pointing out actions necessary for safety. **DO NOT REMOVE OR DEFACE ANY WARNING NOTICE.**

c) Ensure the gas supply is turned OFF at the gas cock.

When service work has been completed gas soundness should always be checked using gas soundness fluid. Recommission the appliance in accordance with the procedure detailed under Installation of the Appliance - Section 5.

## 3 Tools to Undertake Servicing

The following tools will assist in servicing and replacing all appliance components.

Note:- The list includes basic "off the shelf" items and is not intended to preclude the use of alternative specialised tools which may save time.

### LIST OF MINIMUM REQUIRED TOOLS FOR SERVICING

ALLEN KEYS: 4 mm and 5 mm.

SPANNERS OPEN ENDED: 7; 8; 9; 10; 11; 12; 17; 22; 24; 26; 37; 39 mm.

Nº 2 POZIDRIVE SCREWDRIVER WITH PLASTIC HANDLE LENGTH OF SHAFT 250 mm.

Nº 2 POZIDRIVE SCREWDRIVER WITH PLASTIC HANDLE LENGTH OF SHAFT 100-130 mm.

Nº 2 POZIDRIVE SCREWDRIVER WITH PLASTIC HANDLE - STUBBY.

Nº 3 POZIDRIVE SCREWDRIVER WITH PLASTIC HANDLE LENGTH OF SHAFT 100-130 mm.

Nº 3 POZIDRIVE SCREWDRIVER WITH PLASTIC HANDLE - STUBBY.

LIGHT ELECTRICIAN'S TYPE SCREWDRIVER FOR SLOTTED HEADSCREWS - SHAFT 100 mm - BLADE WIDTH 3 mm.

CABINET SCREWDRIVER FOR SLOTTED HEADSCREWS (PLASTIC HANDLE) - SHAFT 100-130 mm - BLADE WIDTH 4-5 mm.

CABINET SCREWDRIVER FOR SLOTTED HEADSCREWS (PLASTIC HANDLE) - STUBBY - BLADE WIDTH 4-5 mm.

CABINET SCREWDRIVER FOR SLOTTED HEADSCREWS (PLASTIC HANDLE) - SHAFT 200-220 mm - BLADE WIDTH 8-10 mm.

PLIERS 6" LONG NOSED WITH PLASTIC HANDLES. SIDE CUT WITH SERRATED JAWS.

ADJUSTABLE SPANNERS -6" AND 10". BACHO OR SIMILAR MOLE WRENCH 8".

STILSON WRENCH 14".

## 4 Servicing of Components

**NOTE THE REPLACEMENT OF COMPONENTS IS DETAILED IN SECTION 5 - page 22.**

**1 Removal of combustion chamber front panel.** Fig. 15.

Remove the two M4 pozidrive screws at the bottom left and right hand sides of the panel. Ease the lower edge of the panel forward

and downward about 10 mm to disengage the locating lugs situated at the top left and right hand sides. The inner face of the panel is lined with insulating material. Pull the panel forward to disengage it. Take care not to allow the insulation pad to fall out.

**2 Removal of the pilot burner assembly.** Fig. 15, 16.

Using a 9 mm open ended spanner remove the thermocouple capillary connector on top of the gas valve. Pull out the ECO lead connection. Refer Fig. 13 and Fig. 29.

a) Unscrew the aluminium pilot pipe connection at the gas valve using an 11 mm spanner.

b) Remove the two M4 pozidrive screws at the left and right hand side of the pilot assembly mounting bracket - attaching the bracket to the main burner assembly.

c) Pull the assembly forward - complete with pilot pipe, electrode lead and thermocouple attached.

d) Hold the assembly by hand or by a suitable tool, such as a mole wrench.

Using a 10 mm open ended spanner unscrew the union connector. Using a pair of long nosed pliers pull the electrode lead off the push on connector at the bottom of the electrode (Fig. 16).

Use the 10 mm open ended spanner to unscrew the union connector at the bottom of the electrode (Fig. 16). Be careful to retain the brass connector. Pull the electrode out of its retaining socket.

Use the 10 mm open ended spanner to unscrew the union connector fixing the aluminium pilot pipe to the pilot assembly. The pilot injector is positioned immediately behind the union connector. Take care when removing the connector. Place the injector and aluminium pilot pipe to one side.

e) Examine the thermocouple. If it shows signs of deterioration replace it.

Examine the electrode lead, particularly the point where it is connected to the electrode. Look also for chafing of the lead. If necessary replace it.

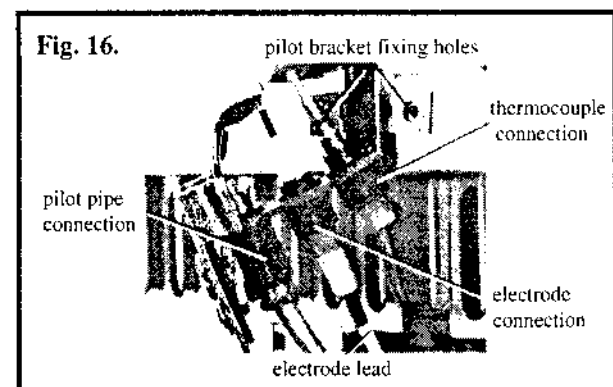
Examine the electrode for damage to the insulation or tip. If damaged replace it.

Examine the pilot injector for damage. Make sure it is free of any foreign matter. If necessary blow through with air. Replace it if damaged in any way.

Examine the pilot shield and pilot assembly in general. If any damage has been sustained, replace it.

Examine the pilot pipe. Ensure it is not kinked and both union connections are in good condition.

NOTES:- As a matter of routine all components should be cleaned of any foreign matter or debris before reassembling.



oce.9306071820

Reassemble in reverse order. Push both the electrode and thermocouple fully home into their respective retaining sockets before tightening the union connectors. Ensure the pilot injector is replaced correctly when refitting the aluminium pilot pipe.

Finally refer to Fig. 13 and check the correct dimensional relationship exists between the individual components. **DO NOT** refit the pilot burner assembly to the main burner assembly at this stage.

**3 Removal of the burner assembly** (Fig. 17).

Remove the burner drip tray by releasing the single screw from the front support bracket and the two screws from the left hand rear support bracket.

Whilst supporting the burner remove the two securing screws that hold the burner frame to the injector manifold at each end of the assembly. The burner can now be eased forward away from the boiler.

Individual burner blades may be removed from the frame by pulling out the two retaining rods from the right hand end of the assembly. Once the rods are removed the bars may be eased out by grasping at both ends and lifting upwards.

Using a brush with non-metallic bristles carefully brush the flame ports and remove any debris from within. Any blade showing signs of deterioration should be replaced on reassembly.

Remove any debris from within the frame of the burner assembly. Ensure all flame ports are clean before reassembling in reverse order.

Note:- The design of all burner blades is identical. It is not necessary to replace them in any particular order.

Ensure each bar is positioned with its venturi inlet lined up with the appropriate hole at the BACK of the frame. All bars should be parallel and pushed as far as possible towards the rear of the frame. Incorrect fitting or misalignment will make it impossible to refit the two retaining rods, which should be pushed fully home. Having reassembled the main burners put the assembly to one side.

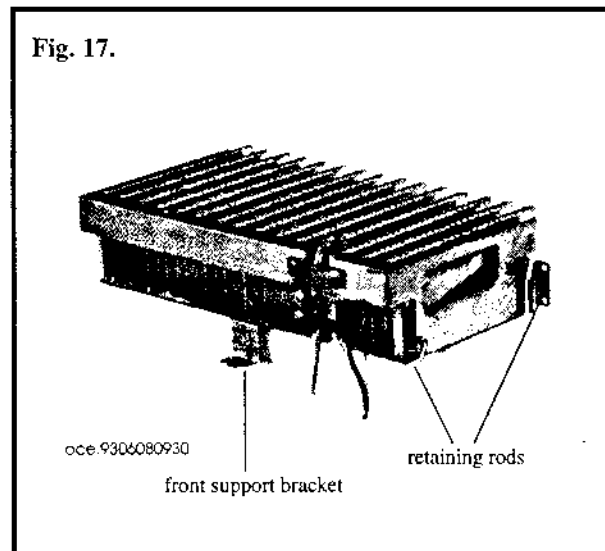
#### 4 Removal of injector manifold (Fig. 18).

Using a 8mm spanner release the four M5 bolts that secure the gas pipe flange to the top of the gas valve.

Release the two screws that secure the injector manifold at both ends to the rear support plate.

Remove the manifold together with the gas pipe from the boiler: using a 7 mm spanner remove and clean or replace any defective injectors. Care should be taken to ensure injectors are not "cross threaded" when being refitted to the manifold.

Should access into the injector manifold be required for cleaning, release the two screws that secure the end plates to the manifold. Reassemble in reverse order using all new seals and washers.



#### 5 Combustion chamber insulation (Fig. 18).

Examine the combustion chamber insulation not forgetting the insulated combustion chamber front panel removed previously. Look for flaking or mechanical breakdown and if necessary replace the insulation.

#### 6 Cleaning the heat exchanger (Fig. 15).

Examine the heat exchanger carefully. If necessary clean the fins using a suitable brush from above and below.

**TAKE CARE NOT TO DAMAGE THE COMBUSTION CHAMBER INSULATION.**

Any debris which has fallen down into the base of the boiler body should now be removed together with the cover over the gas manifold connection before reassembly.

#### Reassembly

Reassemble the components in the following order reversing the procedure used to remove them from the appliance.

injector manifold; burner assembly; pilot burner assembly. **DO NOT OMIT THE PILOT PIPE CONNECTION TO THE GAS VALVE;** fit combustion chamber front panel. **BEFORE PROCEEDING TO RECOMMISSION THE APPLIANCE** (Refer to Installing the Appliance - Section 5). **OBSERVE THE DATA PLATE POSITIONED UNDER THE BOILER ON THE CONTROLS SUPPORT PLATE.**

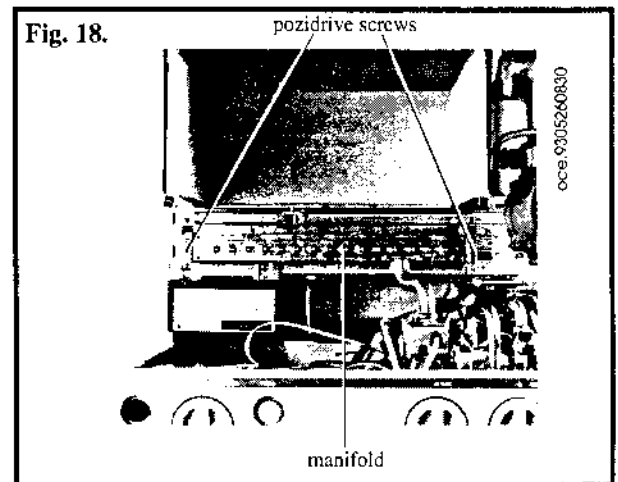
Although the appliance is preset at 14.1 kW (40,000 Btu/h) central heating and 23.4 kW (80,000 Btu/h) domestic hot water output, the central heating output may have been changed during the original commissioning. The central heating service gas pressure should be set to that indicated by the pointer, attached to the data plate. The domestic hot water service gas pressure should be set to achieve 23.4 kW (80,000 Btu/h).

#### 7 Examination of domestic hot water filter

If when recommissioning the appliance (Section 5) and checking maximum DHW flow rate at a tap there appears to be a loss of water pressure, this may be due to dirt in DHW filter.

The filter should be examined and removed / cleaned or renewed as necessary. Access the filter as follows:-

- a) Turn off DHW cold inlet isolation valve.
- b) Open a hot tap to drain down DHW in the pipes.



- c) Release the two M5 bolts which secure the white guard plate and ease the plate sideways to access fully the union nut on the isolation valve.

- d) Slacken the union under the cold inlet isolation valve. Drain any residual water into a suitable receptacle.

- e) Refer to Fig. 19. Slacken the M5 hexagon head screw at the RHS of the retaining plate on top of the pressurestat / diverter valve assembly.

- f) Remove the M5 screw retaining the LHS of the plate and swing the retaining plate away from the LH pipe connection as shown below.

- g) Lift up the front of the pipe and break the 'O' ring seal.

- h) Using the blade of an electrician's screwdriver prise the filter up out of its location.

- i) If the filter requires cleaning, wash thoroughly to remove any debris and replace in position - OPEN END FACING UPWARDS.

- j) If the filter is damaged, renew it.

Reassemble in reverse order and fit a new 'O' ring seal at the pipe entry point.

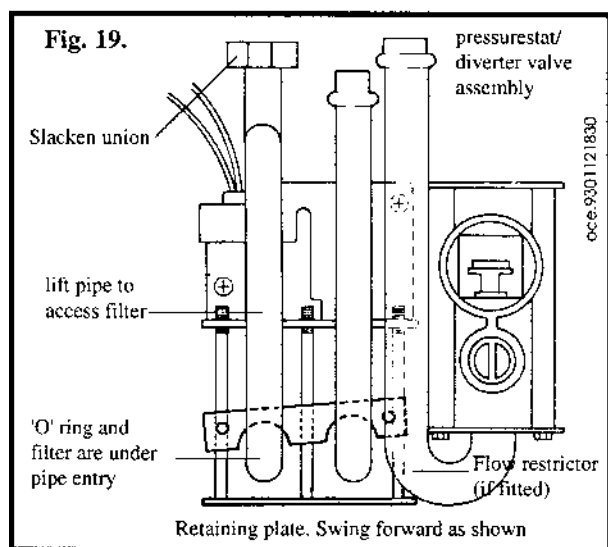
Recheck DHW flow rate at a tap.

#### 8 Examination of water flow restrictor and main diaphragm

With the right hand pipe removed from the top of the pressurestat as detailed in Section 7 above it is possible to see the restrictor but for its removal access must be gained into the Venturi housing below.

Do not prise or lever out the restrictor as this could result in damage to the restrictor or its housing.

- a) Remove the front control panel as detailed in 5.3.
- b) Remove the 6xM5 hexagon headed bolts that secure the pressure stat to the diverter valve.
- c) Once these bolts are released the two sections of the pressure stat together with the main diaphragm can be removed. Set aside for later reassembly the rear plastic section, the main diaphragm and the white centre piston.
- d) From the front section remove the spring E clip and washer from the centre spindle and remove the metal front panel. At this point the plate which is treaded to receive the bolts from pipe retaining plate will fall from its housing. Set aside for reuse.
- e) When viewed from the front remove the right hand round access plug which houses the Venturi, spring and case which can now be removed.
- f) Using bent nosed pliers or similar tool ease upwards the flow restrictor from its housing.
- g) If the restrictor is damaged renew it.
- h) Inspect main diaphragm for damage. If suspect or damaged renew it.



Reassemble in reverse order using new O ring seals at the pipe entry points.

NOTE. When assembling the main diaphragm the circular indentation points to the rear of the pressurestat.

## 5 Replacement of Component Parts

NOTE:- COMPONENT PARTS SHOULD BE REPLACED BY A COMPETENT PERSON ONLY

IMPORTANT:- ISOLATE THE MAINS ELECTRICAL SUPPLY AT THE WALL SOCKET OR SWITCH BEFORE ATTEMPTING TO REPLACE COMPONENT PARTS.

There are various warning notices attached to the appliance pointing out actions necessary for safety. DO NOT REMOVE OR DEFACE ANY WARNING NOTICE. Ensure the gas supply is turned off at the service cock. When a component(s) has been replaced and the appliance reassembled ALWAYS undertake a gas soundness check using gas leakage detection fluid - when it has been necessary to break a gas joint. Recommission the appliance in accordance with the procedure detailed under Installation of the appliance. Section 5.

Section 5 - Index.

- 5.1 Outer casing - for access
  - (a) Removal of combustion chamber front panel
- 5.2 (a) Pilot burner assembly
  - (b) Thermocouple
  - (c) Electrode lead
  - (d) Electrode
  - (e) Pilot injector
  - (f) Main burner
  - (g) Injectors

- 5.3 (a) ON/OFF switch
  - (b) Suppressor
  - (c) Piezo spark generator
  - (d) Safety thermostat and Domestic Hot Water thermostat
  - (e) Control thermostat
- 5.4 Overheat thermostat
- 5.5 Gas valve
- 5.6 Combustion chamber insulation
- 5.7 (a) Water flow switch
  - (b) Euramo Gold Star/Grundfos 15/60 circulating pump
  - (c) Domestic Hot Water heat exchanger
  - (d) Microswitch cover assembly and Domestic Hot Water pressure stat/diverter valve
  - (e) Central Heating expansion vessel
  - (f) Safety valve
  - (g) Domestic Hot Water expansion vessel
  - (h) Pressure gauge
  - (j) Heat exchanger

5.1. Remove the white outer casing by unscrewing the pozipan head screws located on the top and lifting and pulling the casing forward.

a) Remove the combustion chamber front panel (Fig. 15) by unscrewing the two M4 pozidrive screws at the bottom left and right hand sides of the panel. Ease the bottom of the front panel forward and slide it down about 10 mm to disengage the locating lugs situated at the top left and right hand sides. Pull the panel forward to disengage it. Take care not to allow the insulation pad to fall out.

5.2 REPLACEMENT OF THERMOCOUPLE - ELECTRODE LEAD - ELECTRODE - PILOT INJECTOR - PILOT BURNER BRACKET ASSEMBLY WITH SHIELD - MAIN BURNER - INJECTORS. Refer to 5.1 above for procedures (a) to (g).

### a) Pilot burner assembly

Remove the pilot burner assembly complete with thermocouple, ignitor lead and pilot pipe attached, by following the procedure detailed under Section 4 (a); (b); (c).

### b) Thermocouple replacement

Remove pilot burner assembly (5.2a)

Using a 10 mm open ended spanner unscrew the union connector at the base of the thermocouple head. Pull the thermocouple head out of its retaining socket.

Fit a new thermocouple by reversing the procedure above. Ensure the ECO circuit connector is fully home at the gas valve before tightening the thermocouple union connector. Ensure the thermocouple head is pushed fully home into its socket before tightening the union connector at the pilot assembly end.

### c) Electrode lead replacement

Remove pilot burner assembly (5.2a)

Using a pair of long nosed pliers pull the electrode lead off the connector at the bottom of the electrode (Fig. 16) and also from the rear of the Piezo spark generator mounted on the front control cover plate.

Replace the new lead in reverse order.

### d) Electrode replacement

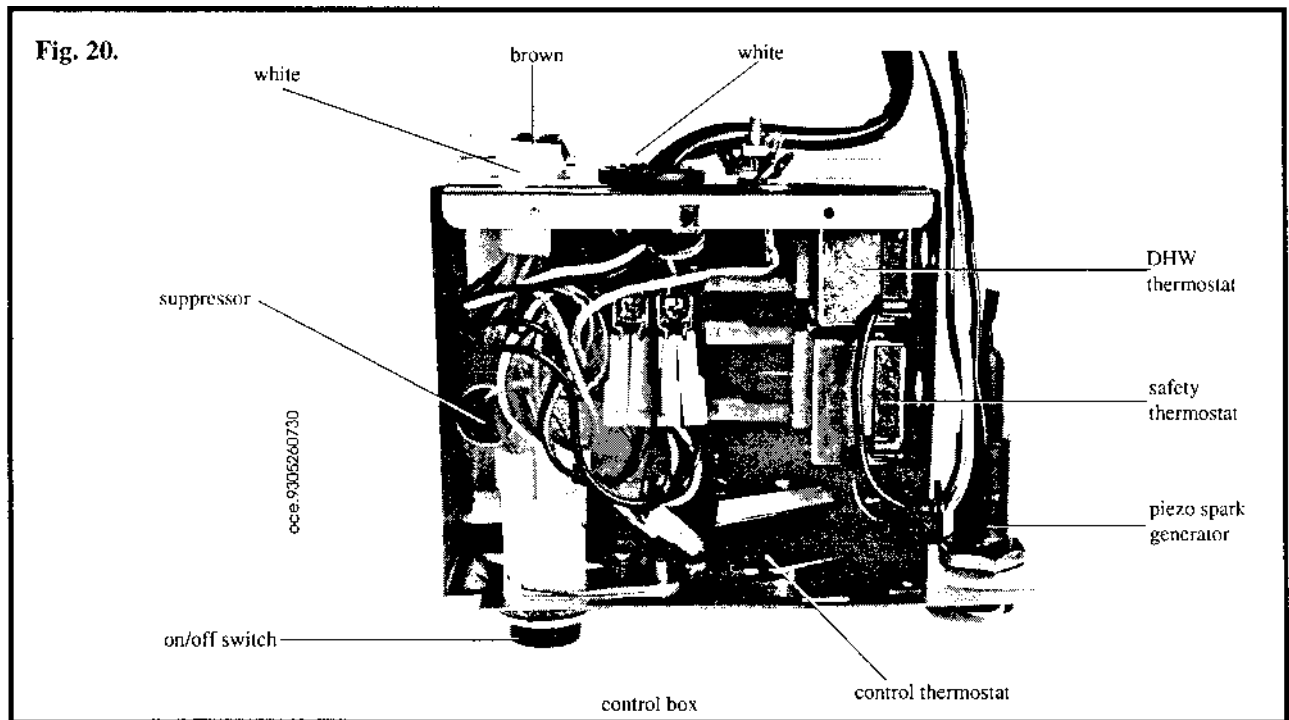
Remove the thermocouple head ONLY from the pilot burner assembly using the procedure in 5.2 (b). Using a pair of long nosed pliers pull the electrode lead off the push on connector at the bottom of the electrode (Fig. 16).

Using a 10 mm. spanner unscrew the union connector at the base of the electrode. Push the electrode out of its retaining socket. Replace with a new electrode - ensuring it is pushed fully home into its socket before fitting and tightening the union connector. Reassemble in reverse order. Finally make sure the electrode tip has the correct relationship with the pilot shield and thermocouple. Refer to Fig. 13.

### e) Pilot injector replacement

Remove the thermocouple head ONLY from the pilot burner assembly (5.2b). Then disconnect the ignitor lead and remove the electrode (5.2d).

Using a 10 mm. spanner unscrew the pilot pipe union connector at the base of the pilot burner. The pilot injector is positioned inside the socket and may FALL OUT unless care is taken in removing the pilot pipe union connector.



Remove the pilot injector. Fit a new pilot injector and reassemble in reverse order. Check the pilot pipe connections for gas soundness using leakage detection fluid. Refer Section 5.3 B(d) - and Fig. 13.

**f) Replacement of main burner**

Refer to 5.1

Remove the pilot burner assembly (5.2a)

Remove the burner (4. (a); (b))

Replace the burner and reassemble in reverse order.

**g) Replacement of injector manifold / injectors**

Remove main burner (5.2 above).

Remove injector manifold / injectors (4.3)

Replace manifold / injectors and washers as necessary.

Reassemble in reverse order.

**5.3 REPLACEMENT OF CONTROL BOX COMPONENTS**

In order to gain access to the control box remove the control thermostat knob. Insert the blade of a stubby flat bladed screwdriver behind the edge of the knob and carefully lever off the shaft. This will expose two pozidrive fixing screws attaching the control panel to the control box behind it. Remove the two screws. **DO NOT REMOVE THE TWO INNER SCREWS** which attach the control thermostat to the control box. The service selector knob is then removed by pushing it off its shaft using finger pressure from behind the control panel. Slacken the two pozidrive screws located at the right hand side of the control panel (top and bottom). Remove the two pozidrive screws located at the left hand side of the control panel (top and bottom). The left hand side of the control panel may now be pulled forward and swung to the right sufficiently to gain access to the control box. Take care not to damage the pressure gauge capillary tube, immediately behind the gauge. Release the catch holding the hinged plate under the boiler (Fig. 11). Turn the knob quarter turn clockwise to release and swing the plate forward. Remove the single pozidrive screw positioned under the control box, fixing it to the main controls support plate. Pull the control box forward to improve access. Remove the single pozidrive screws retaining the cover on top of the control box. Refer to Fig. 20.

When a component(s) has been replaced refix the control box top cover first using the single pozidrive screw at the top, then refit the complete control box to the controls support plate using the single pozidrive screw from the underside.

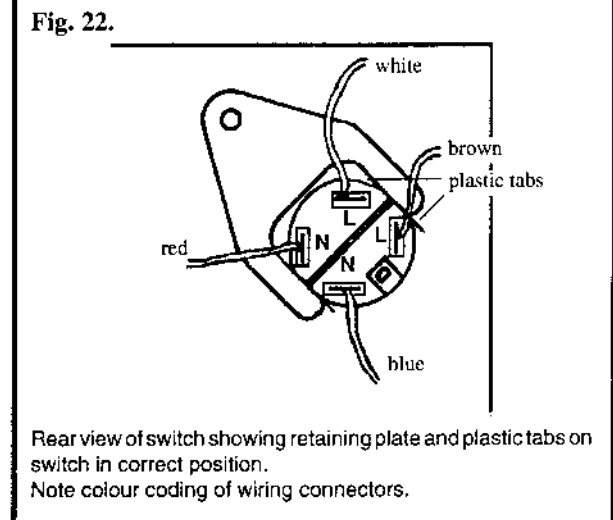
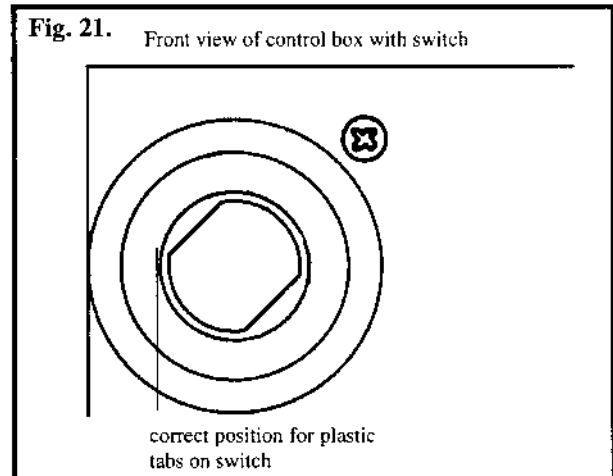
Now reassemble in reverse order.

**NOTE:- ON REASSEMBLY BOTH CONTROL THERMOSTAT AND SERVICE SELECTOR KNOBS ARE SIMPLY PUSHED ONTO THEIR RESPECTIVE SHAFTS.**

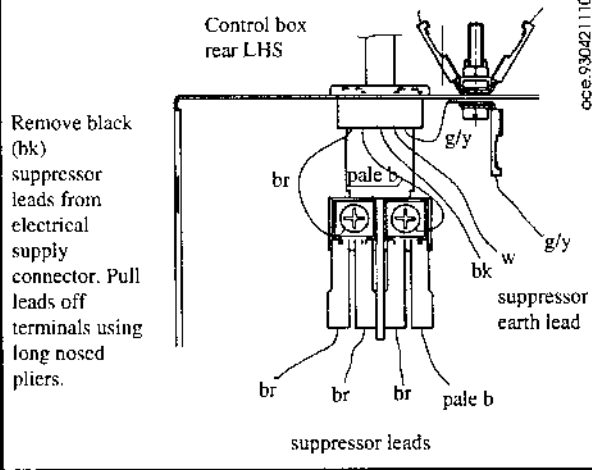
**a) Replacement of illuminated ON/OFF switch**

Using the blade of an electrician's screwdriver inserted behind the plastic tabs, release the switch and remove it with connectors attached through the hole in the control box.

Remove the four push on connectors at the back of the switch (Fig. 22).



**Fig. 23a. CONTROL BOX ELECTRICAL SUPPLY CONNECTOR**



NOTE:- On/off switches are marked clearly 'L' and 'N' and must be replaced in the position shown in Fig. 22 after replacing the push on connectors.

Replace the switch as follows:

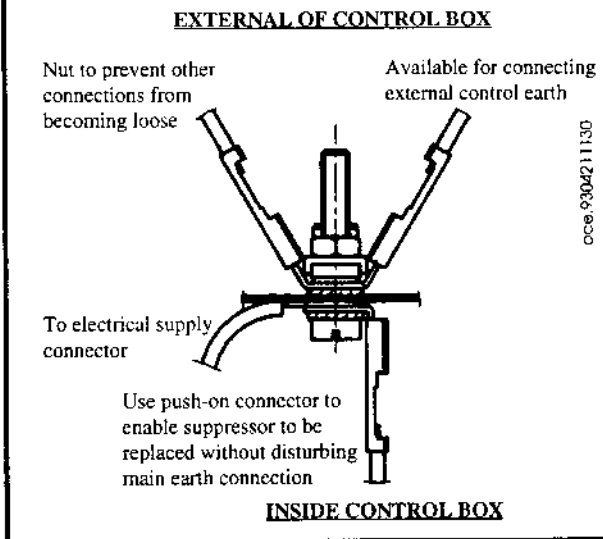
Refit the push on connectors as shown in Fig. 22.

Insert the replacement switch.

Check that the plastic tabs are in the correct position.

Replace the retaining plate and screw.

**Fig. 23b. CONTROL BOX EARTH CONNECTIONS**



**b) Suppressor replacement**

Remove the suppressor from its retaining clip on the left hand side of the control box by sliding forward. Remove the earth wire connected to the suppressor from the brass earthing post at the rear of the control box.

Several earth wire connections are made to the earthing post. When a new suppressor is fitted ensure all earth connections are made positively (Fig. 23).

Fit a new suppressor using the reverse procedure (polarity immaterial).

NOTE:- DO NOT misplace any shakeproof washers.

**c) Replacement of piezo spark generator**

Remove electrode lead and release locking nut securing generator to front plate. Replace new spark generator using reverse procedure.

**d) Control thermostat; safety thermostat and domestic hot water thermostat replacement**

NOTE:- The grommet shown in Fig. 24 is split and a small slot is cut adjacent to the grommet hole in the back of the control box to facilitate removal of the thermostats.

NOTE:- The unlabelled terminals of the top LHS of the DHW and SAFETY THERMOSTATS ARE NOT USED.

**e) Control thermostat replacement**

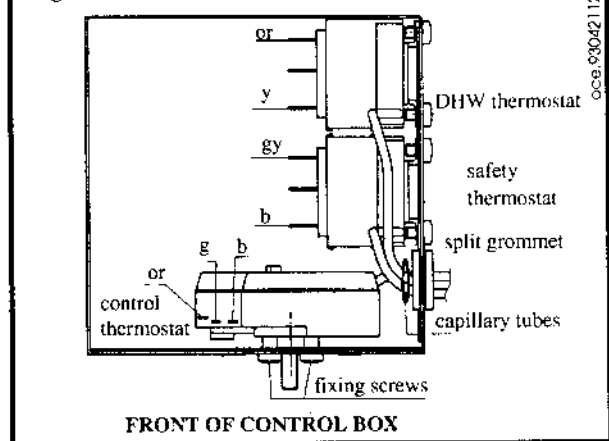
Fig. 24, Fig. 25.

The phial is clamped to the side of the boiler flow pipe. Using finger pressure remove the spring steel retaining clip clamping the phial to the pipe.

Note:- On reassembly ensure the phial is positioned in the centre of the groove indented in the pipe (Fig. 25).

A sachet of heat sink compound is provided with the replacement thermostat which MUST be smeared into the groove on the pipe.

**Fig. 24.**



Note the thermostat capillary route from the thermostat body to the phial. Remove the three insulated connectors from the push on connections on the thermostat body (Fig. 24).

Remove the two pozidrive screws on the front face of the control box, attaching the thermostat body.

Withdraw the capillary tube and phial from behind the control box and gas valve. Remove the thermostat body from inside the control box and feed the full length of the capillary tube in from the right hand side of the control box. Ease the split grommet away from its location to allow the capillary tube pass through the split.

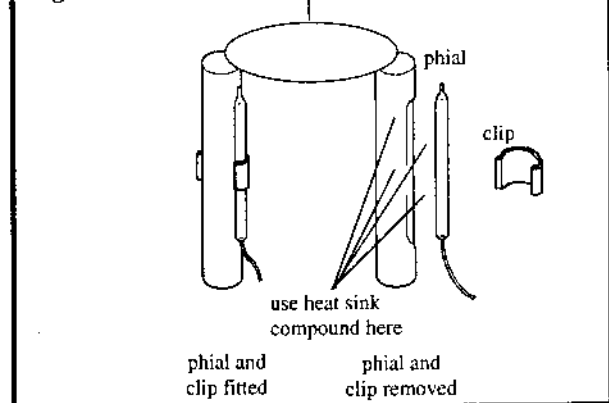
When renewing the thermostat ensure the capillary tube is not kinked or tangled with other components.

Route it behind the gas valve.

REASSEMBLE IN REVERSE ORDER. (Connect thermostat as Fig. 25)

After completing refitment of the control thermostat, ENSURE the insulated connectors to it are secure and in the correct position (Fig. 24).

**Fig. 25.**



**f) Safety thermostat or domestic hot water thermostat replacement**

Identify the respective thermostat phial pocket with phial inserted and the thermostat body. (Fig. 24, Fig. 26 and Fig. 27).

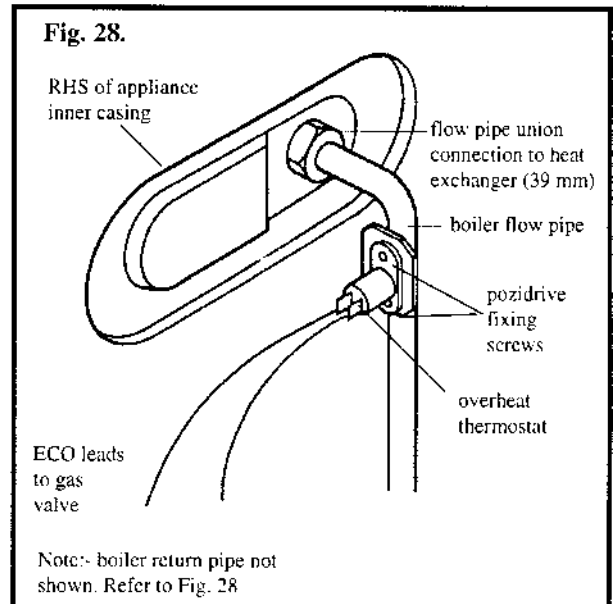
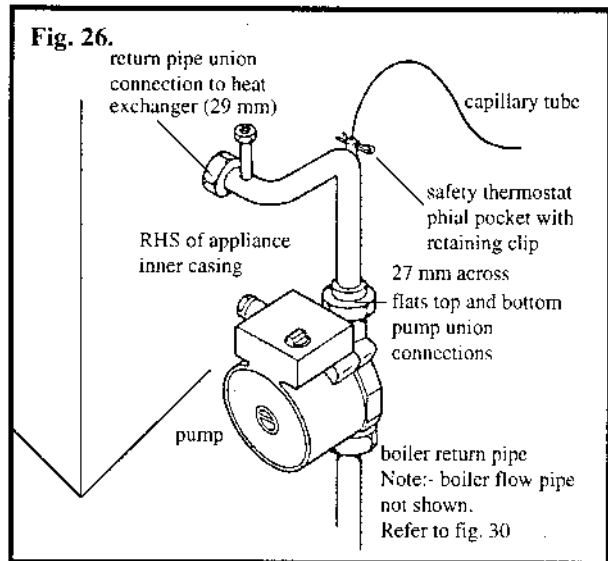
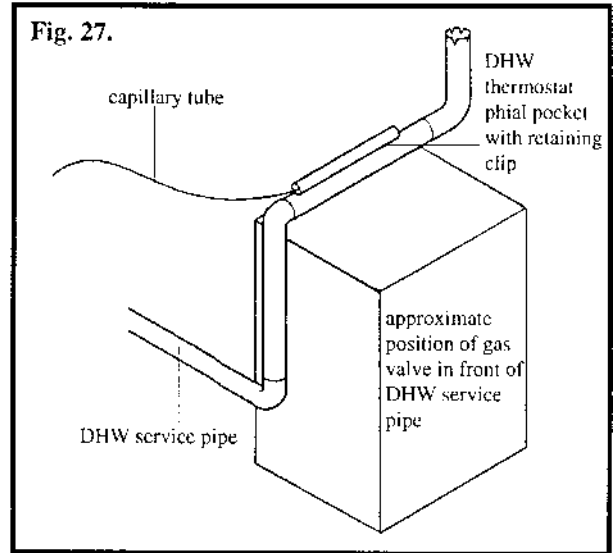
Remove the spring clip retaining the phial. Ensure there is sufficient length of capillary to avoid strain.

NOTE:- A sachet of heat sink compound is provided with the replacement thermostat, which MUST be smeared on the thermostat phial and inside the phial pocket.

Note the thermostat capillary route from the thermostat body to the phial.

Pull off the two insulated connectors at the thermostat body (Fig. 24). Using a 14 mm. spanner remove the single nut on the under side of the control box which fixes the thermostat body to the control box base.

Withdraw the capillary tube and phial from behind the control box and gas valve. Remove the thermostat body from inside the control



box and feed the full length of the capillary tube in from the right hand side of the control box. Ease the split grommet away from its location to allow the capillary tube pass through the split.

When renewing the thermostat ensure the capillary tube is not kinked or tangled with other components.

Route it behind the gas valve.

**REASSEMBLE IN REVERSE ORDER.**

After completing refitment of the safety or domestic hot water thermostat, ENSURE the insulated connectors are secure and in the correct position (Fig. 24).

**5.4 REPLACEMENT OF OVERHEAT THERMOSTAT**

The overheat thermostat is of the surface mounted type and is fixed to a small plate positioned on the boiler flow pipe (RHS) just after the point where the pipe is connected to the heat exchanger. (Fig. 28)

The electrical cut out leads (ECO) are permanently attached to the thermostat at one end (Fig. 28). The opposite ends of the leads are connected (a) to the rear face of the gas valve (Fig. 29) below and (b) the top of the gas valve (Fig. 13) and (Fig. 32).

Remove the hinged panel and guard plate under the boiler. Refer to Section 5 (Fig. 11)

Remove the grey plastic cover over the mains supply connections to the gas valve by unscrewing the single pozidrive screw.

Using a 9 mm. spanner slacken the thermocouple capillary connection on the top of the gas valve sufficiently to pull out the ECO lead connector. Using a 10 mm spanner unscrew the ECO lead connector at the rear of the gas valve.

Remove the two M3 pozidrive screws fixing the thermostat body to the flow pipe mounting plate. Remove the thermostat complete with ECO lead attached. Fit a new thermostat and lead and reassemble using the reverse procedure.

NOTE:- Take care to ensure the ECO leads are securely fixed behind and on top of the gas valve. A sachet of heat sink compound is provided with the replacement thermostat, which MUST be smeared on the face of the thermostat mounting plate.

**5.5 REPLACEMENT OF THE GAS VALVE**

CHECK THE GAS SUPPLY IS TURNED OFF AT THE SERVICE COCK BEFORE PROCEEDING. (Fig. 13); (Fig. 32).

a) Remove the appliance control panel. Refer to Commissioning Section.

b) Remove the grey plastic cover over the mains supply connections to the gas valve by unscrewing the single pozidrive screw. Pull off the two push on connections (LINE AND NEUTRAL) and remove the pozidrive screw and washer retaining the EARTH connection to the valve.

c) Using a 9 mm. spanner slacken the thermocouple capillary connector on top of the gas valve. Pull out the ECO lead connector. Fig. 13 and Fig. 32.

Using an 11 mm. spanner remove the pilot pipe union connector at the gas valve.

d) Slacken the retaining screw at the top of the mains supply plug connected to the HIGH/LOW solenoid valve, sufficiently to allow the plug to be pulled off its connections (Fig. 13).

Remove the hinged panel and guard plate under the boiler (Fig.

11). Refer to Section 5.

Remove burner drip tray (see 3a).

Use a 10 mm spanner to remove the ECO lead union connection at the back of the gas valve. (Fig. 29).

e) Remove the M5 hexagon head fixing screws attaching the top of the gas valve to the manifold pipe flange. Remove the four M5 hexagon head fixing screws and washers attaching the underside of the gas valve to the controls support plate and gas service cock outlet flange.

Remove the 'O' ring seals at the top and bottom of the valve during its removal and RENEW THEM ON REASSEMBLY.

Remove the appliance control panel.

The valve body can now be moved forward, clear of the appliance. Fit the new valve and reassemble in reverse order. Ensure the new 'O' ring seals are positioned correctly at the top and bottom of the valve.

## 5.6 REPLACEMENT OF BOILER COMBUSTION CHAMBER INSULATION.

Refer to Fig. 15 and Fig. 33.

Remove the burner assembly (Section 4)

(a) Remove the insulation pads A1 (LEFT HAND) AND A2 (RIGHT HAND) by sliding forward out of the combustion chamber

(b) Lower or break out the bottom rear insulation pad by using a screwdriver or similar. Pull down and forward the top insulated panel B2.

Note:- The insulation material is not of high mechanical strength; take care when replacing it.

(c) When replacing, insert panel B2 first and support it in its correct position.

(d) Insert the top edge of panel B1 into position under panel B2 and then swing it up, pushing it under the bottom edge of panel B2.

(e) Panels A1 and A2 can now be fitted.

Slide each panel back until it touches and supports the rear panels. Refer to Fig. 34. The combustion chamber front panel insulation should now be removed and replaced as shown.

When the new insulation pad is fitted correctly there will be a gap of about 12 mm at each end.

(f) Reassemble the appliance in reverse and undertake gas soundness checks.

## 5.7 REPLACEMENT OF COMPONENTS REQUIRING ISOLATION OF THE APPLIANCE FROM THE CENTRAL HEATING (PRIMARY) AND DOMESTIC HOT WATER (SECONDARY) CIRCUITS AND DRAINING OF THE BOILER.

In order to remove certain component it will be necessary to drain down the appliance. Before attempting to do so.

NOTE: SEALED SYSTEMS MAY BE FILLED COMMISSIONED OR DRAINED BY A COMPETENT PERSON ONLY (Fig. 8)

1. Remove the hinged panel and guard plate under the boiler. Refer to Section 5 (Fig. 11)

2. Turn off the appliance DHW cold inlet isolation valve.

3. Open a hot tap to drain down the DHW pipes.

4. Turn off the appliance central heating flow and return isolation valves.

5. Drain via system or boiler drain cock.

### a) Replacement of the Water Flow Switch

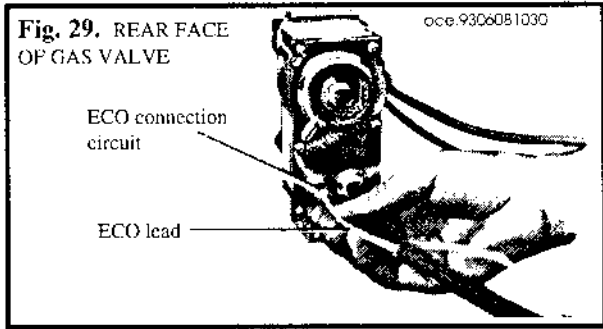
Fig. 30; Fig. 35. Identify the switch positioned at the right hand side of the appliance inner casing, just above the boiler return pipe. Remove the cover from the switch by unscrewing the FOUR pozidrive fixing screws.

Pull off the connectors and remove the supply cable, complete with strain relief bush, away from the area of the switch.

Refer to Fig. 35 and note the TWO union connections, above and below the front of the switch diaphragm, made to the copper sensing pipes.

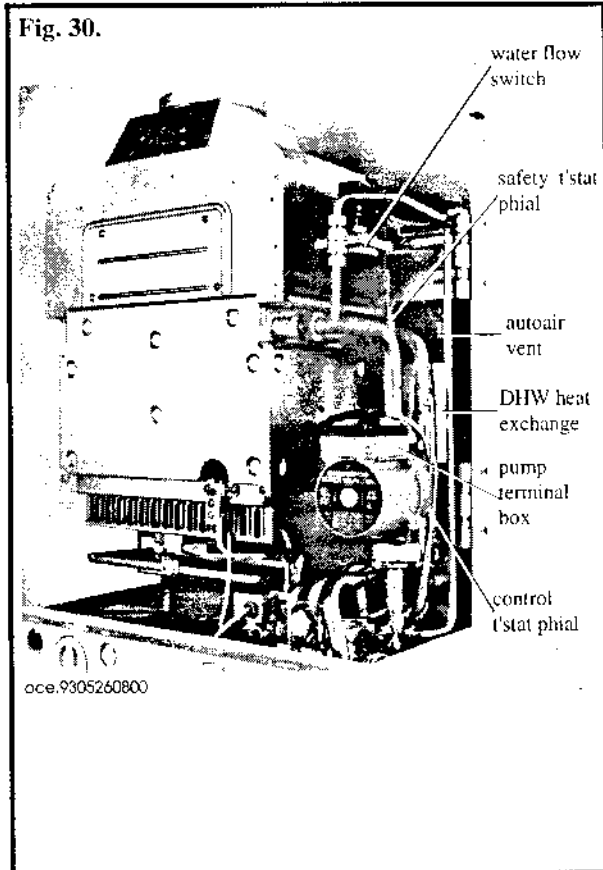
Using a 17 mm spanner and a 6" adjustable spanner release the top union connection. Support the switch diaphragm and release the bottom union connection.

Remove the plastic switch body complete with diaphragm. Renew the switch assembly, reassembling in reverse order. Check that both union connector sealing washers are fitted. Note:- Ensure the electrical connections and the cable grommet are correctly positioned (Fig. 35). Ensure the cable is adequately clamped when



replacing the plastic switch cover.

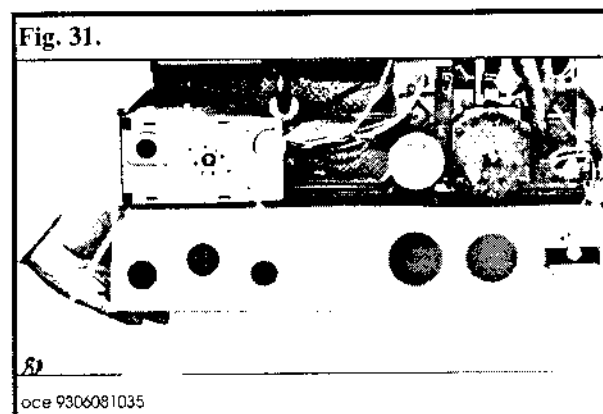
Before opening the isolation valves and refilling the system - REFER TO PAGE 8 - REQUIREMENTS FOR SEALED SYSTEMS SECTIONS 7 AND 8 and Fig. 3.



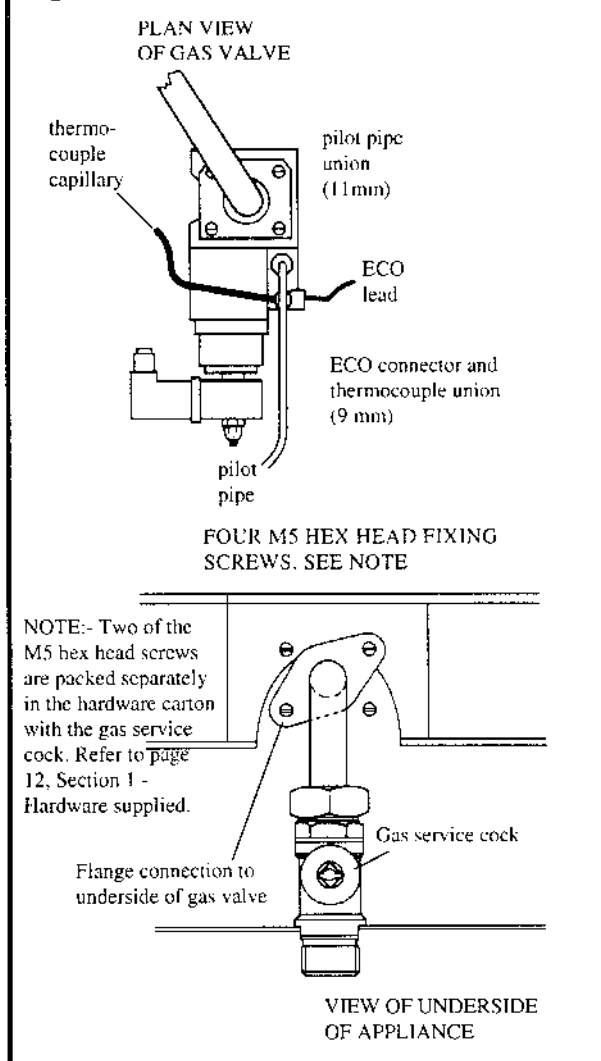
### b (i) Replacement of Euramo Gold Star / Grundfos 15/60 Circulating Pump - complete

First remove the appliance control panel.

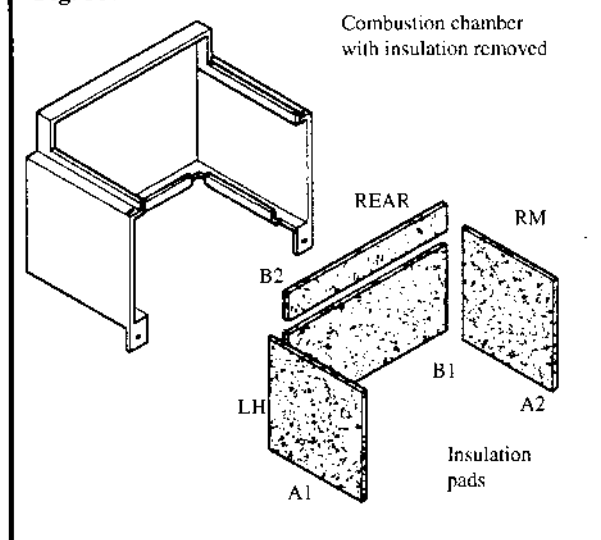
NOTE:- Before pulling the front panel off the supporting side



**Fig. 32.**



**Fig. 33.**



panels, release the union connector attaching the pressure gauge capillary tube to the appliance return pipe - just below the circulating pump. (Fig. 30), (Fig. 36). Observe, when releasing the union, there are TWO remaining union connections to the same fitting. They are the water flow switch sensing pipe (RHS) and the connecting pipe from the expansion vessel (REAR). A 6" adjustable spanner may be used to release them. Remove the safety thermostat phial from its

pocket. (Section 5.3d)

Release the union connection below the water flow switch diaphragm and then the union connection at the point where the water flow switch sensing pipe joins the appliance return pipe, below the pump. (Fig. 30), (Fig. 35).

Lift the water flow switch assembly and sensing pipes clear and support it at the rear of the appliance.

Now release the remaining union connection at the rear of the fitting.

**REFER TO FIG. 36; FIG. 37; FIG. 40 AND IDENTIFY THE DIVERTING VALVE - BELOW THE PUMP.**

Unscrew the TWO M5 hexagon head screws indicated 'A' using an 8 mm spanner and/or a screwdriver, sufficiently to allow the retaining plate to be pulled upwards and released. Put the plate to one side.

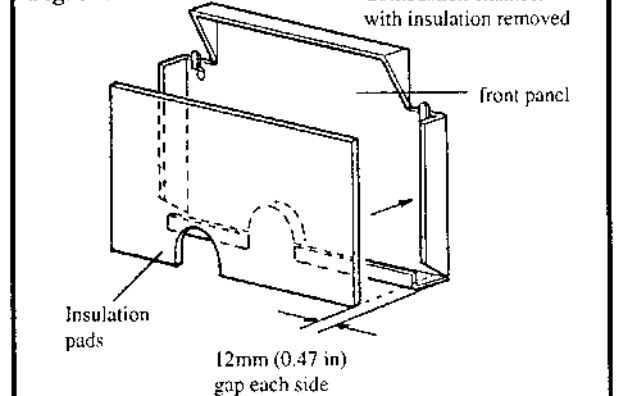
Note the plate is held in position within slots at the front and rear. Remove the pozidrive screw retaining the plastic cover over the electrical connections to the pump. Lift off the cover. Remove the three wires connected to the exposed terminal block or pump casing (EARTH) Fig. 37. Release the union connection at the point where the boiler return pipe enters the heat exchanger, using a 29 mm or adjustable spanner. (Fig. 26).

Grasp the pump and pipework assembly and lift it VERTICALLY upwards, out of the top of the mixing valve. Using an open ended spanner, release the gland nut clamping the three core electrical cable and withdraw the cable out of the entry hole.

The pipework may now be removed from the pump using a 27 mm spanner in combination with a 14" stilson wrench.

**NOTE:-** On reassembly, replacement of components will be made easier if the short length of pipe between the top of the diverter valve and the pump inlet is fixed first (Fig. 36). The expansion vessel connection can then be made more easily. The rest of the components, comprising of the pump itself and the short return pipe to the heat exchanger, may then be fitted as a rigid sub-assembly.

**Fig. 34.**



Replace the pump using the reverse of the above procedures.

**ENSURE:-** All sealing washers and 'O' ring seals are renewed and replaced correctly on reassembly. Observe correct polarity when rewiring the pump. Refer to Fig. 37.

Before the isolation valves are turned on and refilling the system - REFER TO PAGE 8 - REQUIREMENTS FOR SEALED SYSTEMS - SECTIONS 7 AND 8 AND FIG. 3.

**b (ii) Replacement of circulating pump - motor only.**

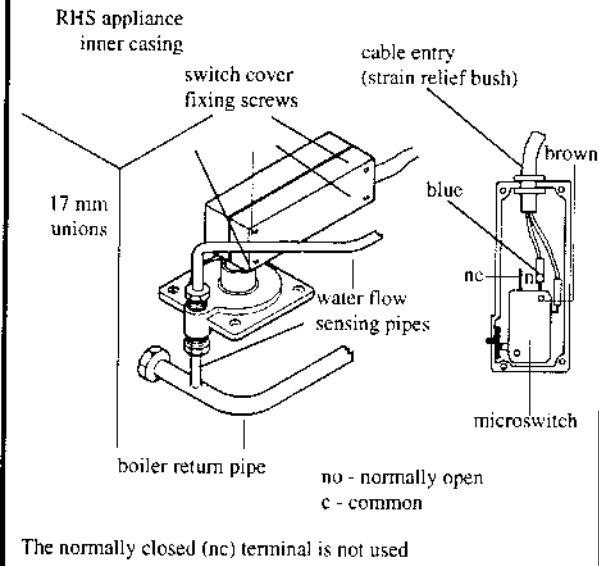
Ensure the boiler is drained down fully. Refer to the figure below. The Euramo - Gold Star pump is fitted, only TWO socket head screws are used. If the Grundfos 15/60 pump is fitted then 4 socket head screws are used.

Remove the pozidrive screw retaining the plastic cover over the electrical connections to the pump. Remove the three wires connected to the exposed terminal block of pump casing (EARTH) Fig. 37.

Use a 4 mm allen key to remove the socket head screws attaching the pump motor to the rotor housing. Pull the motor away from the housing: some leverage may be required if the pump has been in situ for some time.

Support the motor. Using an open ended spanner, release the

**Fig. 35. WATER FLOW SWITCH WITH COVER REMOVED**



gland nut clamping the three core cable and withdraw the cable out of the entry hole.

The pump rotor will come away with the motor and is replaced with it. Ensure the rotor housing is clean and that the entry and exit ports are free from sludge or hardened deposits.

When fitting a new motor / rotor assembly ensure the new 'O' ring seal between the motor and rotor housing is fitted correctly. Reassemble in reverse order; observe polarity when wiring the pump (Fig. 37)

Finally ensure that any pump speed adjustment fitted is set at maximum.

Before opening the isolation valves and refilling the system, REFER TO PAGE 8 - REQUIREMENTS FOR SEALED SYSTEMS - SECTIONS 7 AND 8 AND FIG. 3.

**c) Replacement of Domestic Hot Water Heat Exchanger**

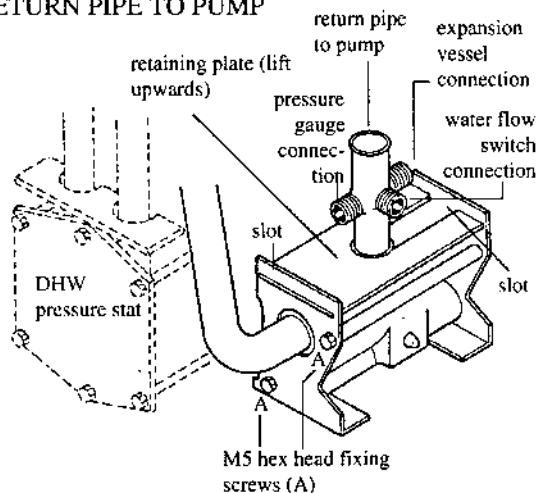
Remove stainless steel pressure vessel and connecting pipework (if fitted). Remove the circulating pump complete with connected pipework as detailed in Section 5.7 b (i) - page 26. Place the assembly to one side.

The heat exchanger, complete with top mounted air vent, is situated at the REAR RIGHT HAND SIDE of the appliance.

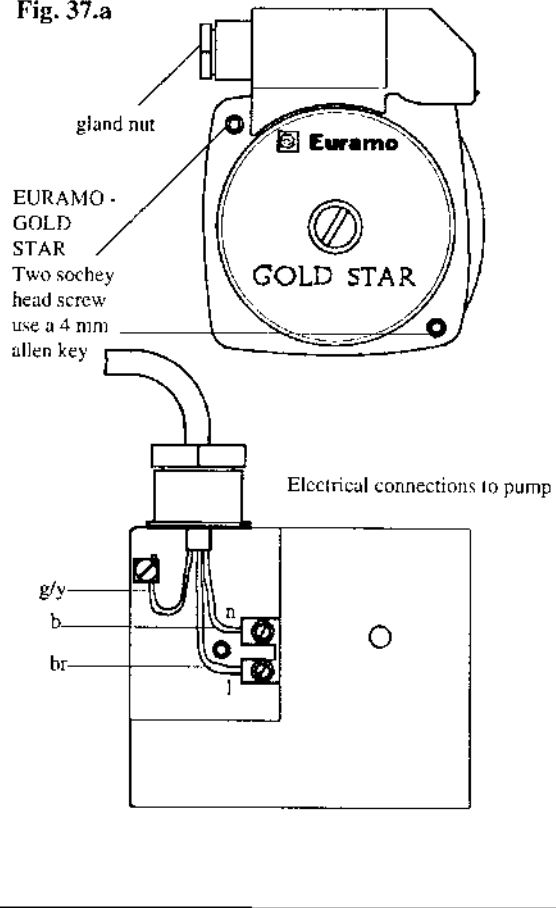
Identify it and the pipework connections at its base by referring to Fig. 15 and Fig. 38.

Remove the control thermostat phial from the boiler flow pipe. Refer Section 5.3d (i). Unscrew the TWO M5 pozidrive screws fixing each retaining plate to the base of the heat exchanger.

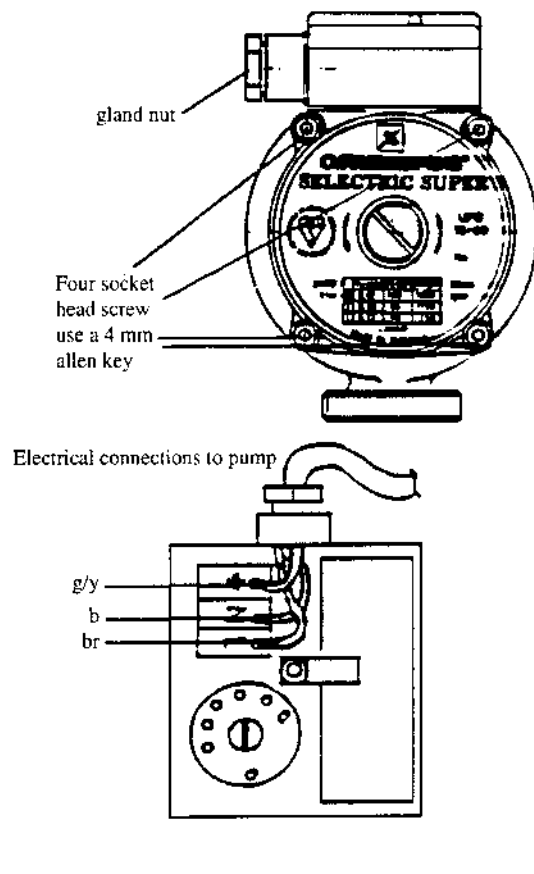
**Fig. 36. THREE WAY DIVERTER VALVE RETURN PIPE TO PUMP**



**Fig. 37.a**



**Fig. 37.b GRUNDFOS 15/60**



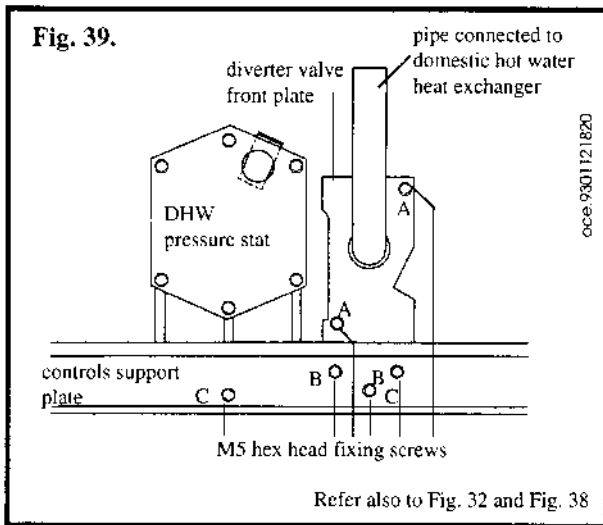
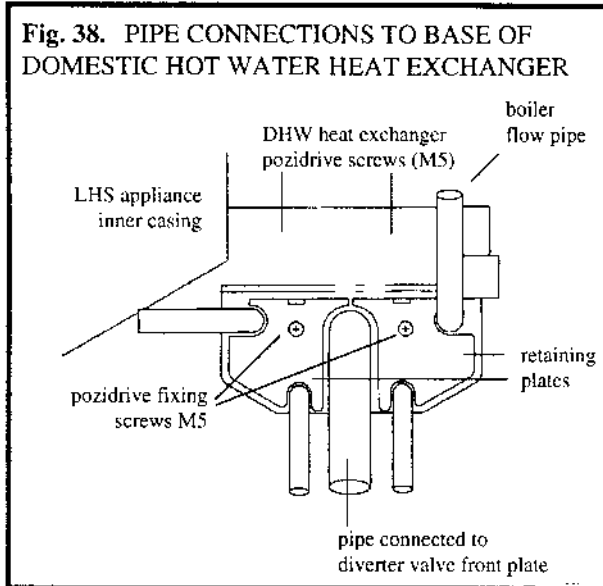
Remove the plates, complete with screws by means of the small extension lug at the top of each plate.

Remove the limit thermostat from the boiler flow pipe by releasing the two pozidrive screws fixing the limit thermostat body to the flow pipe mounting plate. Release the union connecting the boiler flow pipe to the boiler heat exchanger using a 39 mm or adjustable spanner. Fig. 28.

Unscrew completely the TWO hexagon head screws 'A' retaining the front plate of the diverter valve. DO NOT REMOVE THEM AT THIS STAGE. Refer Fig. 36.

Remove the TWO M5 hexagon head screws 'B' underneath the front plate, attaching it to the controls support plate.

The 'O' ring seals made at the point where each pipe enters the base of the domestic hot water heat exchanger can now be broken



by pulling each end forward slightly. Remove the boiler flow pipe by disconnecting the already released union at the boiler heat exchanger.

NOTE:- The pipe joining the domestic hot water heat exchanger to the FRONT plate of the mixing valve has an 'O' ring seal at BOTH ENDS.

Remove the TWO M5 pozidrive screws fixing the domestic hot water heat exchanger to the back of the support member together with the plastic strap. The heat exchanger can now be lifted out VERTICALLY, over the top of the appliance. Replace the heat exchanger using the reverse of the above procedure. Ensure renewal of ALL 'O' ring seals.

Transfer the automatic air vent to the new heat exchanger. Before opening the isolation valves and refilling the system - REFER TO PAGE 8 - REQUIREMENTS FOR SEALED SYSTEMS - SECTION 7 AND 8 and Fig. 3.

**d) Replacement of microswitch cover assembly - domestic hot water pressure stat and diverter valve**

**i) Microswitch cover assembly**

Remove stainless steel pressure vessel and connecting pipework (if fitted).

Remove the circulating pump complete with connected pipework as detailed in Section 5.7 b (i)

Unscrew the M5 pozidrive screw, fixing the LEFT HAND retaining plate to the base of the domestic hot water heat exchanger. Remove the plate, complete with screws. (Fig. 36)

Release the union connection at the BOILER SIDE of the domestic hot water mains inlet isolation valve. Use a 24 mm or adjustable spanner. (Fig. 8).

Refer to Fig. 40. Using an 8 mm spanner unscrew the TWO M5 hexagon head screws fixing the pipe retaining plate at the top / front of the pressure stat. Then pull the other end of the pipe out of its retaining hole in the pressure stat. Lift off the plate.

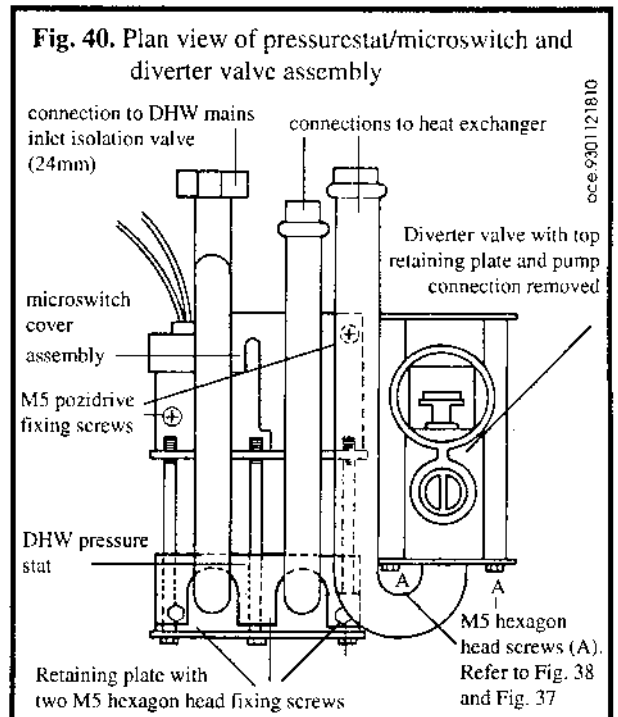
Pull the LEFT HAND pipe up, out of its retaining hole in the pressure stat. This will release the pipe.

Pull the RIGHT HAND pipe up, out of its retaining hole in the pressure stat. Pull the other end of the pipe out of its retaining hole in the base of the domestic hot water heat exchanger. This will release the pipe.

Push the remaining pipe slightly and remove the TWO M5 pozidrive screws attaching the microswitch cover assembly to the top of the pressure stat. Lift the assembly slightly to ensure the fixing screws are clear, then remove and retain them.

Lift up the cover assembly and disengage it from the main pressure stat body. Note there are two cable connections to the rear of the cover assembly.

Remove the SINGLE pozidrive screw positioned underneath the



control box, which fixes it to the main controls support plate. Pull the control box forward to improve access. Remove the BROWN plug from its socket. Check the route taken by the two cables connected to the brown plug and the microswitch cover assembly. Remove the cover assembly (Fig. 41) by passing the cables and plug behind the gas valve and out over the top of the pressure stat / diverter valve assembly. Replace the component and assemble in reverse order. Before opening the isolation valves and refilling the system - REFER TO PAGE 8 - REQUIREMENTS FOR SEALED SYSTEMS - SECTION 7 AND 8 and Fig. 3. Ensure all 'O' ring seals and washers are in place.

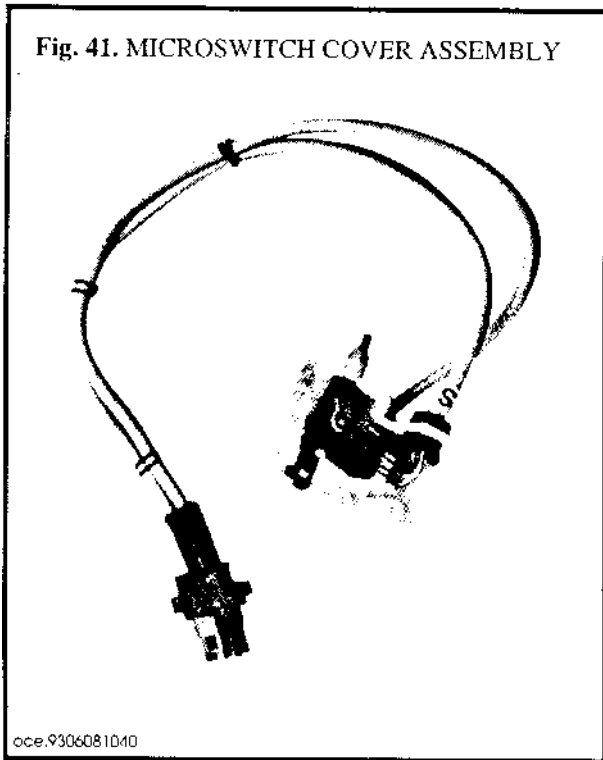
**ii) Domestic hot water pressure stat and diverter valve**

Remove the microswitch cover assembly. Section 5.7d (i).

Release the union connection at the BOILER SIDE of the central heating RETURN isolation valve. Use a 30 mm or adjustable spanner.

Refer Fig. 8.

Using an 8 mm spanner release completely the TWO M5 hexagon head fixing screws 'A'. Refer Fig. 36 and Fig. 39.



Unscrew the M5 pozidrive screw fixing the RIGHT HAND retaining plate to the base of the domestic hot water heat exchanger. Refer Fig. 38.

Remove the plate, complete with screw.

Refer to Fig. 39 and note the FOUR M5 hexagon head fixing screws 'B' 'C' fixing the assembly to the main control support plate.

Using an 8 mm spanner or screwdriver remove the two M5 hexagon head screws 'B', immediately underneath the front plate of the diverter valve. Pull the copper pipe forward, breaking the 'O' ring seals at the base of the domestic hot water heat exchanger and the front of the diverter valve.

Note:- The end of the pipe joining the mixing valve will come away complete with front plate, long fixing screws and steel clip.

Pull off the steel clip attached to the pipe and pass the end of the pipe through the hole in the front plate.

Refer to Fig. 39. Using an 8 mm spanner or screwdriver remove the TWO remaining M5 hexagon head screws 'C' retaining the pressure stat / diverter valve assembly to the controls support plate. The assembly can now be lifted clear of the appliance and replaced - reassembling in reverse order.

Note: When reassembling ensure all 'O' ring seals and washers are renewed. Fit the copper pipe to the front of the mixing valve before offering up the new assembly to the boiler for fixing. DO NOT OMIT the steel spring clip.

Before opening the isolation valves and refilling the system - REFER TO PAGE 8 - REQUIREMENTS FOR SEALED SYSTEMS - SECTION 7 and 8 and Fig. 3.

#### e) Replacement of Expansion Vessel

The expansion vessel is situated at the rear of the boiler. Under certain conditions of installation the boiler must be removed from the wall to allow access for removal of the vessel.

(i) If the appliance is either fitted with a 135° bend direct into the flue spigot, or if there is a clearance of less than 350 mm (13 in) above the white casing IT IS NOT POSSIBLE TO REMOVE THE VESSEL IN SITU - REFER TO (ii) OR (iii) BELOW.

(ii) If a clearance of at least 330 mm (13 in) is available above the white casing, proceed as follows:-

Drain down the boiler in accordance with the procedure under

Section 5.7.

Release the screws that hold the support brackets and remove the burner drip tray.

Refer to Fig. 42. Release the copper pipe union connection at the base of the expansion vessel using a 17 mm or adjustable spanner.

Unscrew the hexagon head nut holding the pressure vessel on the support bracket. Use either a 22 mm or adjustable spanner.

Lift the pressure vessel upwards and out of the boiler. Replace with a new vessel and connect it to the bracket and copper pipe union. DO NOT FORGET THE SHAKE-PROOF WASHER.

Before opening the isolation valves and filling the system - REFER TO REQUIREMENTS FOR SEALED SYSTEMS - SECTIONS 7 and 8 and Fig. 3.

(iii) If the vessel is faulty or if any leak can be isolated, then if preferred the vessel can be isolated and a vessel of at least equivalent capacity can be fitted. This MUST be situated in the RETURN to the boiler as close as possible to the boiler. DO NOT FIT A VESSEL IN THE FLOW TO THE BOILER.

To remove the boiler from the wall, proceed as follows:-

After draining down the boiler in accordance with the procedure under Section 5.7 undertake the following.

Check that the electrical supply to the appliance is turned OFF at the isolation switch and that any clock or heating controls fitted are in the OFF position. Turn OFF the gas service cock. (Fig. 12)

Locate the black plastic cover over the terminal block into which the electrical supply to the appliance is wired. (Fig. 4).

The cover is positioned under the left hand side of the boiler inner casing.

Release the two pozidrive screws retaining the cover, remove it to expose the terminal block.

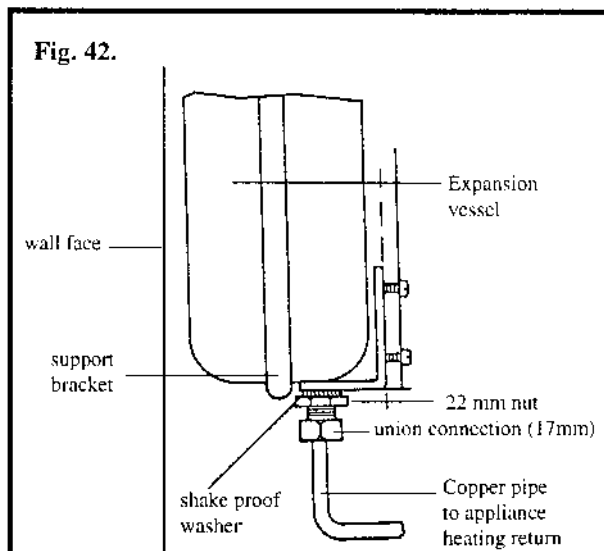
NOTE the position of any cables connected to the block. Disconnect them using an electrician's screwdriver.

Remove the TWO pozidrive screws retaining the cable clamp and withdraw the cables to the rear. Ensure the cables are free from the appliance when it is removed from the wall.

Check that draining down has been successfully undertaken and that all FOUR union connections on the BOILER SIDE of the isolation valves have been released.

Disconnect the drain pipe from the safety valve.

Refer to Fig. 32. Note the TWO M5 hexagon head screws fixing the gas service cock outlet flange to the gas valve.



Using an 8 mm spanner or a screwdriver remove the two screws and retain them for reassembly.

Refer to Fig. 15.

Lift the appliance about 10 mm and draw it forward to clear the supporting lugs at the rear left and right hand side of the jacket side panels.

Lay the appliance face down on a suitable support such as two wooden battens. This will expose the expansion vessel at the rear of the boiler. Refer to Fig. 42 and note the method of supporting and fixing the expansion vessel.

Release the copper pipe union connection at the base of the

expansion vessel using a 17 mm or adjustable spanner. Unscrew the hexagon head nut holding the pressure vessel on the support bracket. Use either a 22 mm open ended or adjustable spanner. Lift the pressure vessel upwards out of the boiler. Replace with a new vessel and connect it to the bracket and copper pipe union. **DO NOT FORGET THE SHAKE PROOF WASHER.** Lift the appliance back onto its wall plate ensuring the supporting lugs are properly engaged.

Using the reverse of the above procedures, remake all water, gas, flue and electrical connections.

**NOTE:-** Be sure to undertake gas and water soundness checks before attempting to light the appliance or operate the system. Replace the gas cock 'O' ring seal and all sealing washers at the central heating and domestic hot water connections to the appliance. Refer to Sections 3 to 6 inclusive.

Before opening the isolation valves and filling the system - REFER TO PAGE 8 - REQUIREMENTS FOR SEALED SYSTEMS - SECTIONS 7 AND 8 and Fig. 3.

#### f) Replacement of safety valve

Identify the safety valve (Fig. 8). The valve is positioned under the left hand side of the appliance behind the main controls support plate.

Disconnect the drain pipe from the safety valve. Use a 26 mm or adjustable spanner to remove the safety valve from the left hand side of the central heating flow isolation valve. Replace the valve using an approved jointing compound around the thread (APPROVED TO BS 5292:1980).

Refit the safety valve drain pipe.

Before opening the isolation valves and filling the system - REFER TO PAGE 8 - REQUIREMENTS FOR SEALED SYSTEMS - SECTIONS 7 AND 8 and Fig. 3.

#### g) Replacement of stainless steel domestic hot water expansion vessel (if fitted)

The vessel is positioned under the water flow switch above the pump.

Release the vessel from the pipework by unscrewing the securing nut counterclockwise.

Replace the vessel - AND SEALING WASHER.

Before opening the isolation valves and refilling the system - REFER TO PAGE 8 - REQUIREMENTS FOR SEALED SYSTEMS - SECTIONS 7 AND 8 and Fig. 3.

#### h) Replacement of pressure gauge

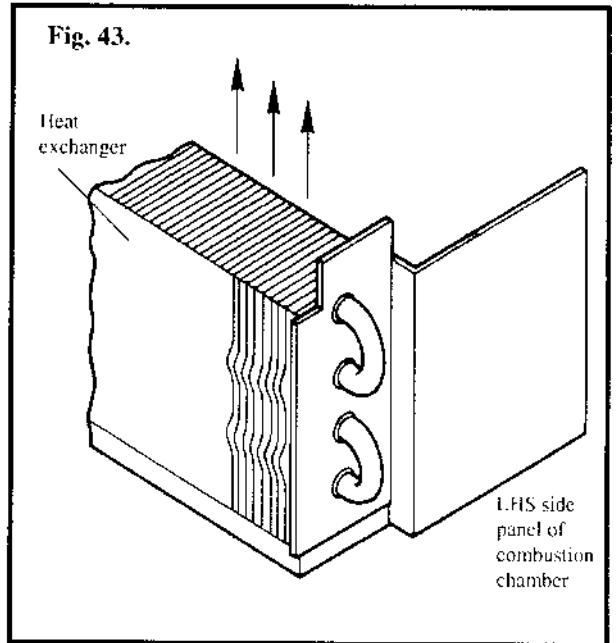
After draining down the boiler in accordance with the procedure under Section 5.9, identify the pressure gauge at the right hand end of the control panel. Fig. 14.

Remove the white outer casing by releasing the two retaining screws and pull forward at the top left and right hand sides.

Remove the control thermostat knob by inserting a small broad bladed screwdriver around the edge of the knob and lever off the shaft. This will expose TWO pozidrive screws attaching the control panel to the control box behind it. Remove the two screws. **DO NOT REMOVE THE TWO INNER SCREWS** which attach the control thermostat to the control box. Remove the service selector knobs by pushing it off the shaft using finger pressure from behind the control panel. Slacken the TWO pozidrive screws located at the left hand side of the control panel (top and bottom). Remove the pozidrive screws located at the right hand side of the control panel (top and bottom).

The right hand side of the control panel may now be pulled forward sufficiently to expose the back of the pressure gauge.

Refer to Fig.36. Using a 17 mm or adjustable spanner release the union connector at the point where the pressure gauge capillary



joins the boiler return pipe.

Release the brass retaining nut behind the pressure gauge, remove the clamping bar and remove the gauge by passing the capillary out through the hole in the front panel. Replace the gauge using the reverse of the above procedure.

Ensure a new fibre sealing washer is fitted at the union connection.

#### j) Replacement of boiler heat exchanger and/or combustion chamber insulation

Refer to Fig. 15.

Remove the appliance combustion chamber front panel and pilot burner assembly. Sections 4.1; 4.2; 4.3 (a) (b) (c) - page 20.

Remove the burner assembly. Refer to Section 5.2.

Unscrew the union connections at the heat exchanger flow and return pipe entry. (Fig. 26 and Fig. 28).

Support the heat exchanger and combustion chamber assembly and remove the TWO pozidrive screws at the bottom left and right hand side of the combustion chamber side panels. The screws attach the side panels.

The heat exchanger and combustion chamber can now be removed from the rear support frame.

Lay the assembly on its back as shown in Fig. 43.

Grasp the front of the heat exchanger and, whilst supporting the combustion chamber, lift it up and away from the combustion chamber in the direction of the arrows (Fig. 43). **BE CAREFUL NOT TO PULL THE REAR INSULATION PAD (FIG. 33) AWAY WITH THE HEAT EXCHANGER, OTHERWISE THE INSULATION MAY BE DAMAGED.**

Fit a new heat exchanger by sliding it down on to the top of the combustion chamber using the reverse procedure.

Replace the combustion chamber / heat exchanger assembly and reassemble the appliance in reverse order.

Ensure all inner boiler casing screws are fitted correctly. Renew the fibre washers at the flow return union connections to the heat exchanger.

Undertake water soundness checks.

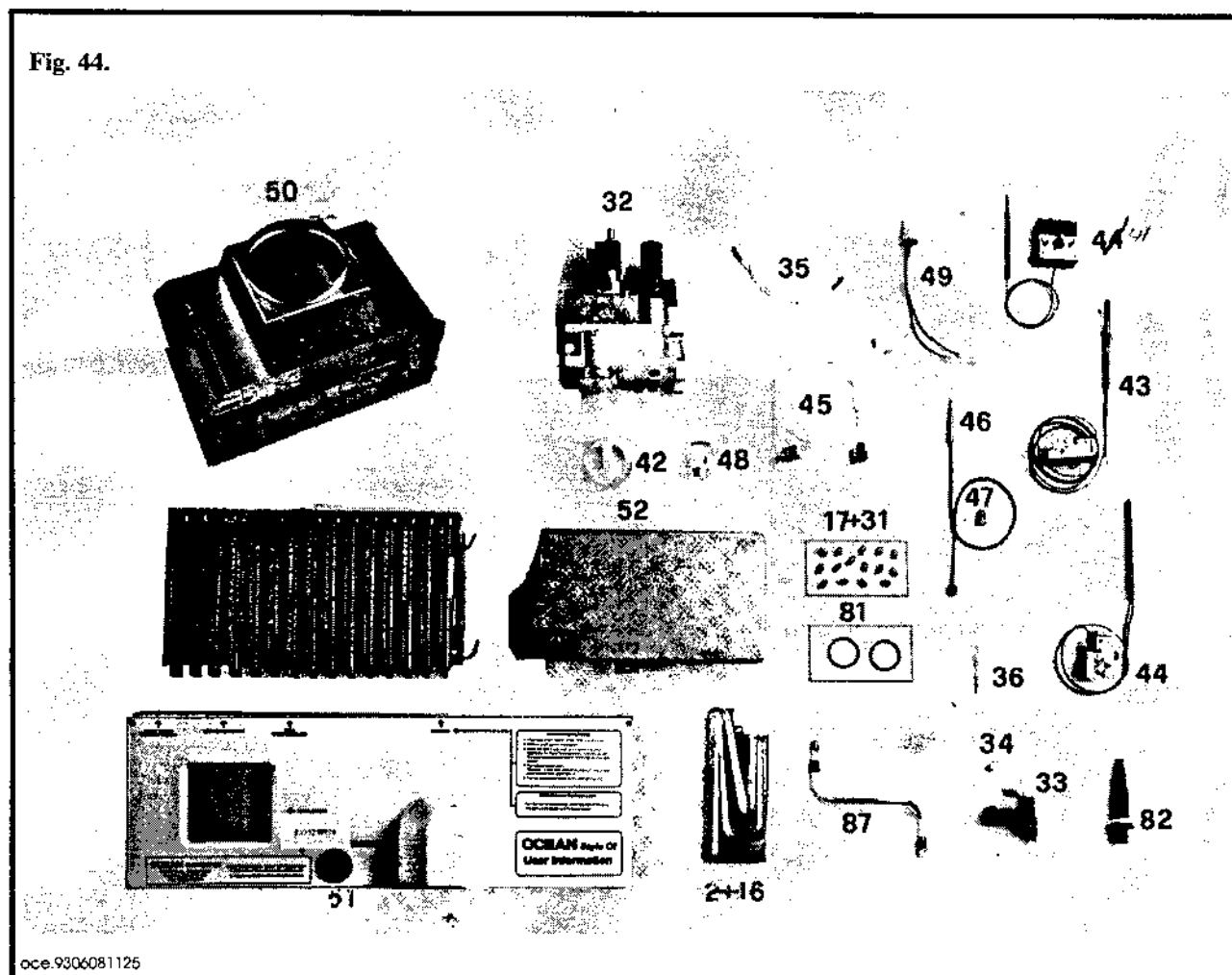
# SHORT PARTS LIST

Key No	GC N°	Description	No.	Ocean Part No.
1		Burner assembly comprising 15 removable burner blades, support frame and retaining rods. Type OF Manufacturer OCEAN Spa.	1	JJJ005615061
2-16		Removable burner blade. Type OF Manufacturer OCEAN Spa.	15	JJJ005604091
17-31		Burner injector. Size 1.18 mm. Type Natural gas, Manufacturer: Min-Tor Meccanica	15	JJJ005617041
32		Gas valve. Size 1/2", Type V4600Q2034, Manufacturer HONEYWELL.Natural Gas	1	JJJ005615071
32A		Gas valve. Size 1/2", Type V4600P2044, Manufacturer HONEYWELL. LPG Note: item 81 also required	1	JJJ005620101
33		Pilot bracket.	1	JJJ005614791
34		Pilot injector.Type 0.140, Size 0.27 mm, Manufacturer SIT.	1	JJJ005201551
35		Electrode lead. Length 450 mm, Manufacturer: S.K.G.	1	JJJ008413451
36		Electrode - Spark. TypeTarget Manufacturer SIT.	1	JJJ008420931
37		Circulating pump. Manufacturer EURAMO. Type GOLD STAR.K Note: item 38 also required	1	JJJ005617241
38		'O' ring seals fibre washer kit for item 37	1	JJJ005615081
			1	JJJ005607293
			1	JJJ005614701
*41		Control thermostat. Type KT 170 Manufacturer: METALFLEX. Length of capillary 800mm	1	JJJ005614811
42		Control thermostat knob.	1	JJJ005616401
*43		Safety thermostat. TypeK36 L3258.Manufacturer:RANCO length of capillary 1200 mm.	1	JJJ005614821
43A		Safety thermostat. IMIT SPA TR2/ST alternative to key N° 43		
*44		Domestic hot water thermostat. Type K36 L3259 Manufacturer RANCO. Length of capillary 450 mm	1	JJJ005614831
44A		DHW thermostat. IMIT SPA TR2/DHW alternative to key N° 44		
*45		Over heat thermostat and ECO lead. Type 36T21-12348. Manufacturer: THERMODISC.	1	JJJ005614841
45A		Over heat thermostat. ELTH 261P alternative to key N° 45		
46		Thermocouple.Type 0290136 Manufacturer SIT.Length of capillary 450 mm.	1	JJJ005614721
47		Connector for thermocouple	1	JJJ005202491
48		Illuminated ON/OFF switch. Manufacturer: MOLVENO COMETTI.	1	JJJ008432991
49		Suppressor - Radio: Type, F.AT.AG.2680 ZB 020. Manufacturer ARCOTRONICS alternative: Type, 411.13.2100. Manufacturer PROCOND	1	JJJ005624801
50		Natural draught diverter	1	JJJ005624601
51		Hinged plate with retaining knob	1	JJJ005618061
52		Drip-Tray	1	JJJ005618601
58		Water flow sensor switch. Type SFS 1 Manufacturer: MUT. MECCANICA Note: items 59 also required	1	JJJ005615371
59		Fibre washer kit for item 58	1	JJJ005615091
60		Domestic hot water heat exchanger. Type: UK Manufacturer: OCEAN SPA Note: also 61 item required	1	JJJ005610361
61		'O' ring kit for item 60	1	JJJ005614761
62		Microswitch cover assembly for water pressure stat complete with leads and plug. Manufacturer: OCEAN SPA Note: item 63 also required	1	JJJ005617081
63		'O' ring and fibre washer kit for item 62	1	JJJ005615101
64		Water pressure stat and diverter valve assembly. Type: OF. Manufacturer: OCEAN SPA Note: item 65 also required	1	JJJ005617091
65		'O' ring and fibre washer kit for item 64	1	JJJ005614781
66		Service selector knob	1	JJJ005618331
67		Expansion vessel Manufacturer: ZILMET Capacity 7 litre. Items 79; 82 and 84 also required	1	JJJ005610141
68		Domestic hot water pressure vessel. Type Z160 Manufacturer, ZILMET Capacity: 0,16 litre Item 69 also required (if fitted)	1	KIG714010110

\* These items supplied complete with sachet of heat sink paste.

Key No	GC. No	Description	No.	Ocean Part No.
69		Fibre washer kit for DHW pressure vessel preformed pipework	1	JJJ005615111
70		Boiler heat exchanger. Manufacturer: GIANNONI Note: item 71 also required	1	JJJ009950120
70A		Boiler heat exchanger. OCEAN/CM alternative to key N° 70		
*71		Fibre washer only required for item 70 and 70A	1	JJJ005620111
72		Safety valve. Type: 1/2" Manufacturer ORKLI. Setting pressure 3 bar	1	JJJ005608551
73-77		Combustion chamber insulation panels. Type: Style FF	5	JJJ005614731
78		Fibre washer kit for water union connections on INLET side of wall template.	1	JJJ005617101
79		Fibre washer kit for water union connections on BOILER side of wall template.	1	JJJ005617101
80		Gas cock. Manufacturer: CIMBERIO	1	JJJ005614281
81		Gas valve 'O' ring seals at inlet and outlet of gas valve.	2	JJJ005615121
82		Piezo spark generator	1	JJJ008433221
83		Fibre washer for water flow switch copper sensing pipe union connection to boiler return pipe.	1	JJJ005617211
84		Fibre washer for pressure gauge capillary union connection to boiler return pipe.	1	JJJ005402081
85		Pressure gauge. Manufacturer: T e G. Note: item 86 also required	1	JJJ008922201
86		Fibre washer for item 85	1	JJJ005402081
87		Pilot pipe complete with connectors	1	JJJ005614851
88		Domestic hot water filter and 'O' ring seals	1	JJJ005615131
89		Water flow restrictor and 'O' ring seals		

Fig. 44.



oce.9306081125

Fig. 45.A

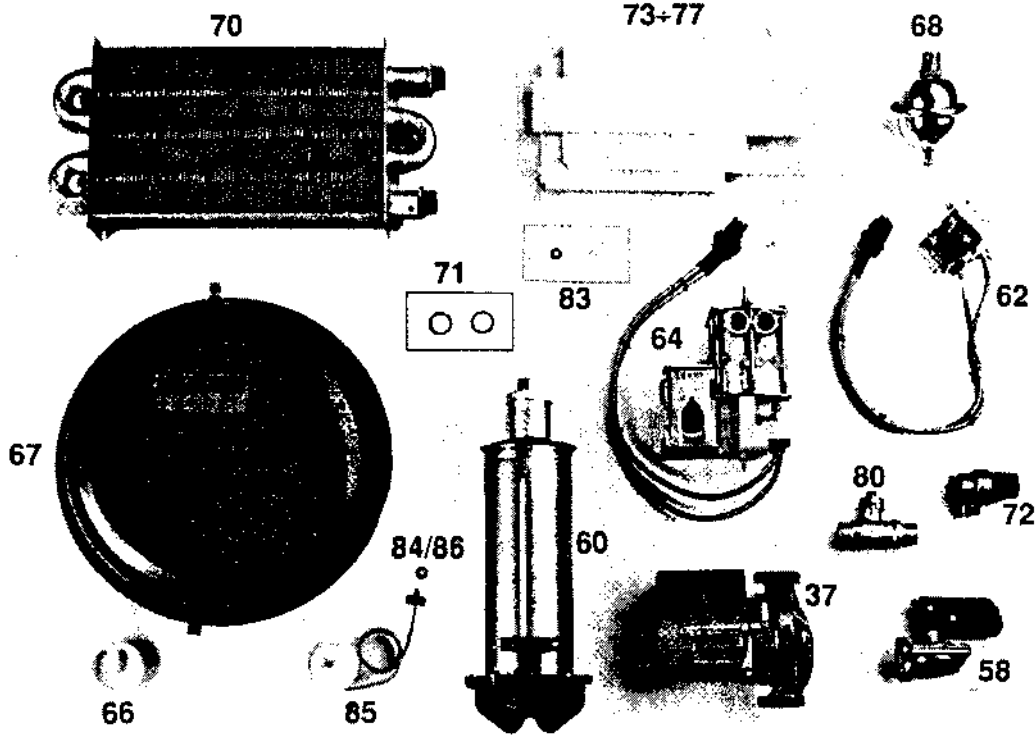
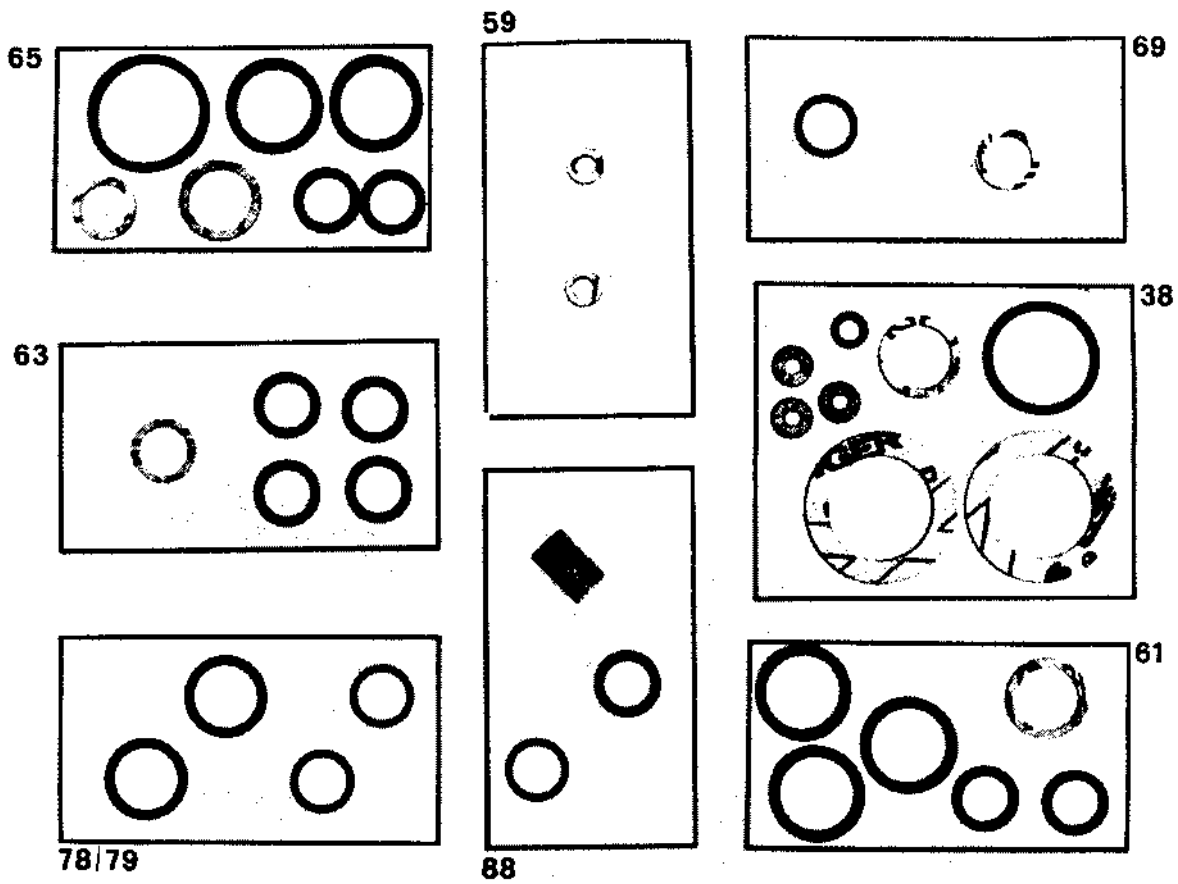


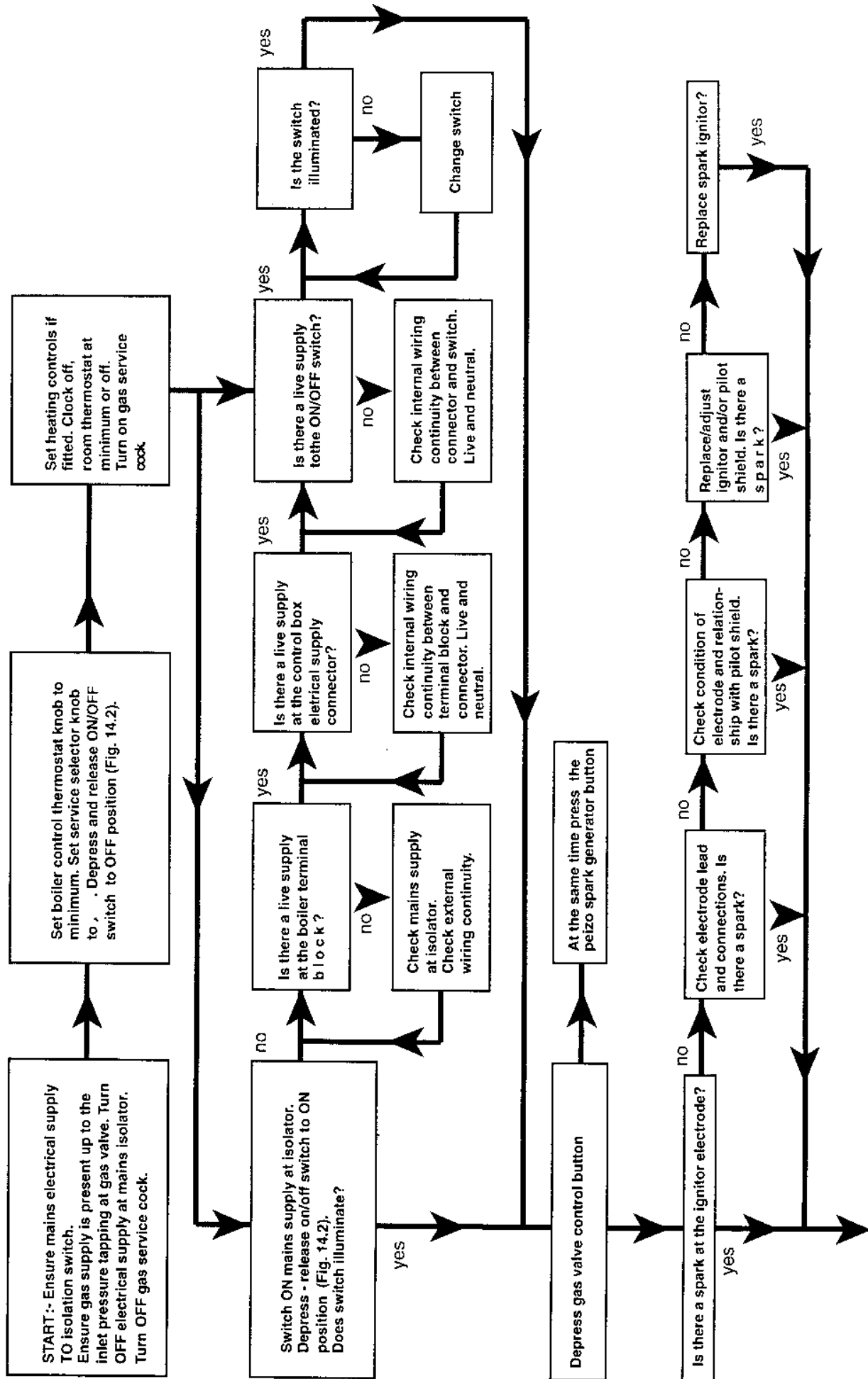
Fig. 45.B

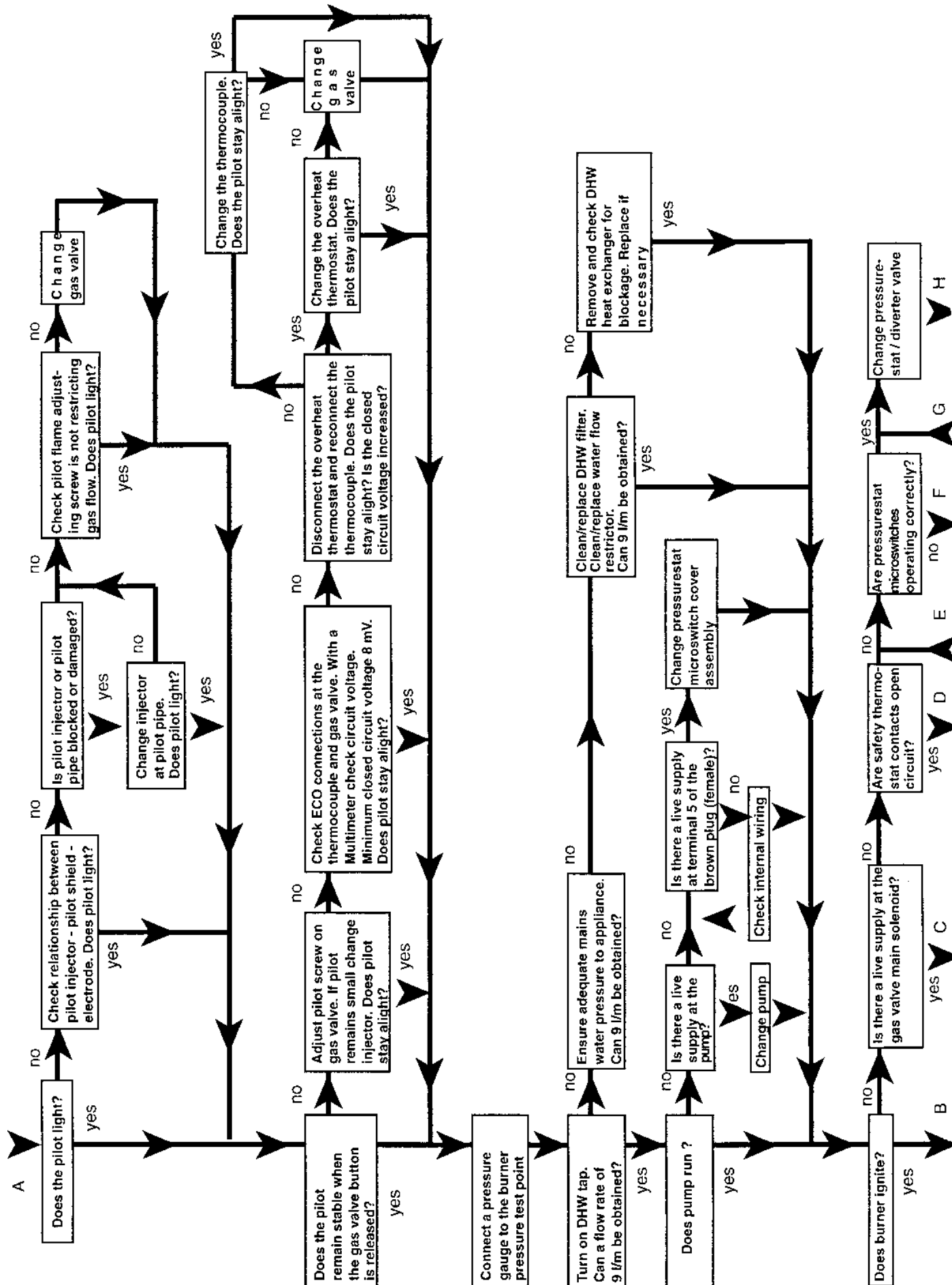


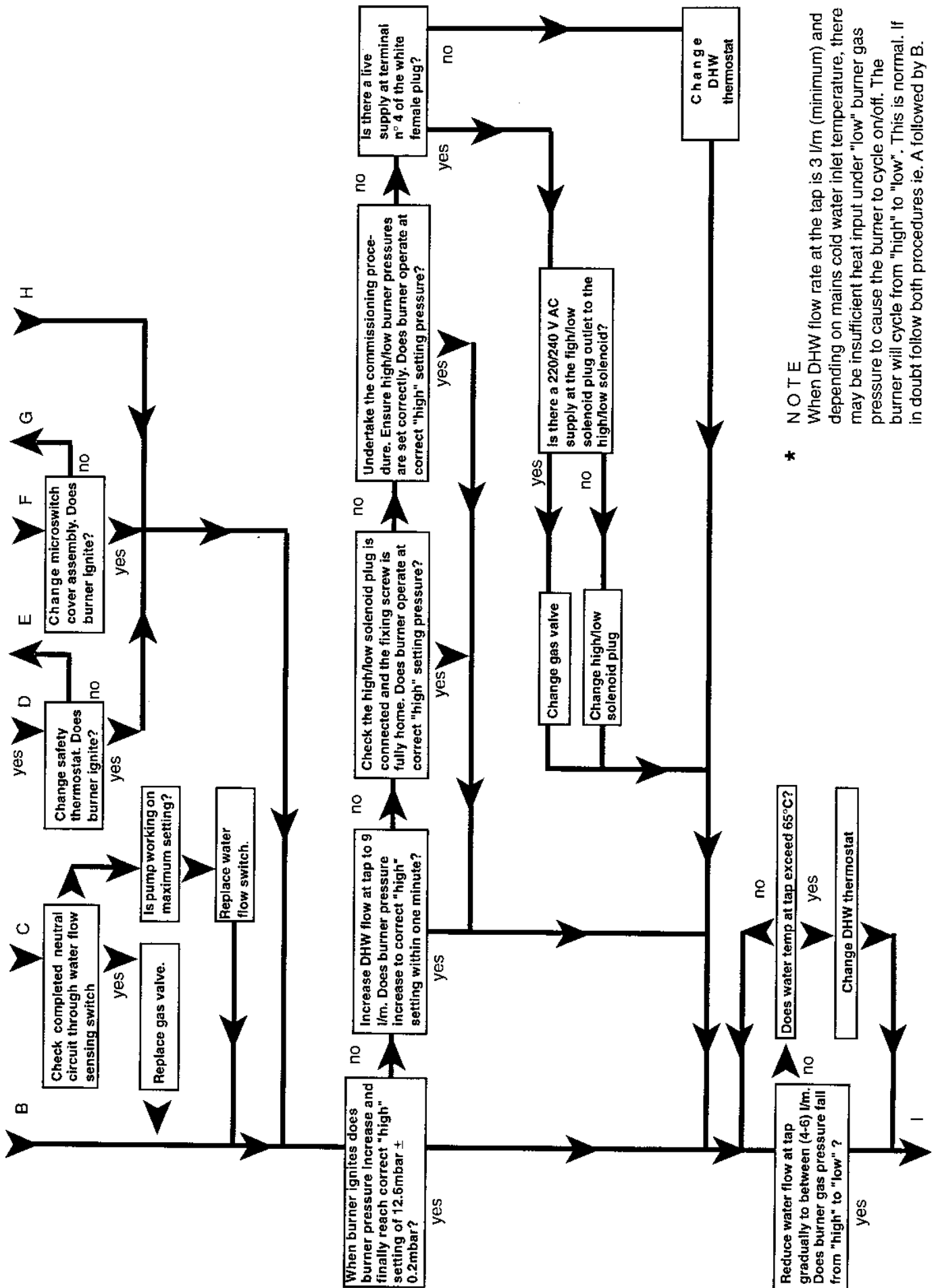
oce.9306081140

# FAULT FINDING CHART

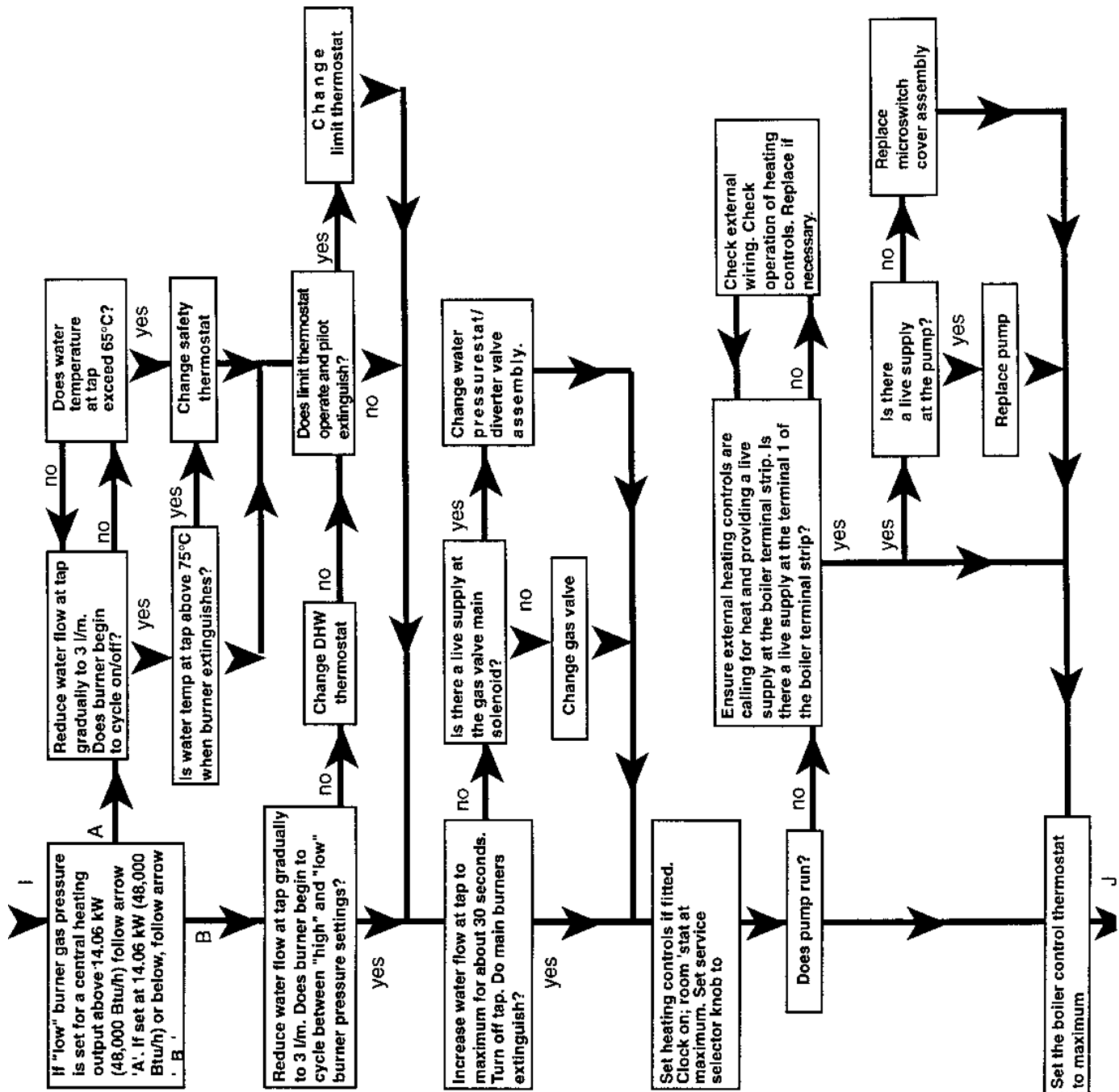
**IMPORTANT NOTE:** The FIRST electrical checks to be undertaken during a fault finding procedure are the preliminary electrical checks. ENSURE that whenever a Servicing or Fault Finding check has been undertaken which has required the breaking and remaking of electrical connections, the checks A: EARTH CONTINUITY; B: SHORT CIRCUIT; C: POLARITY; D: RESISTANCE TO EARTH - ARE REPEATED ALWAYS check wiring continuity between components before replacing them.

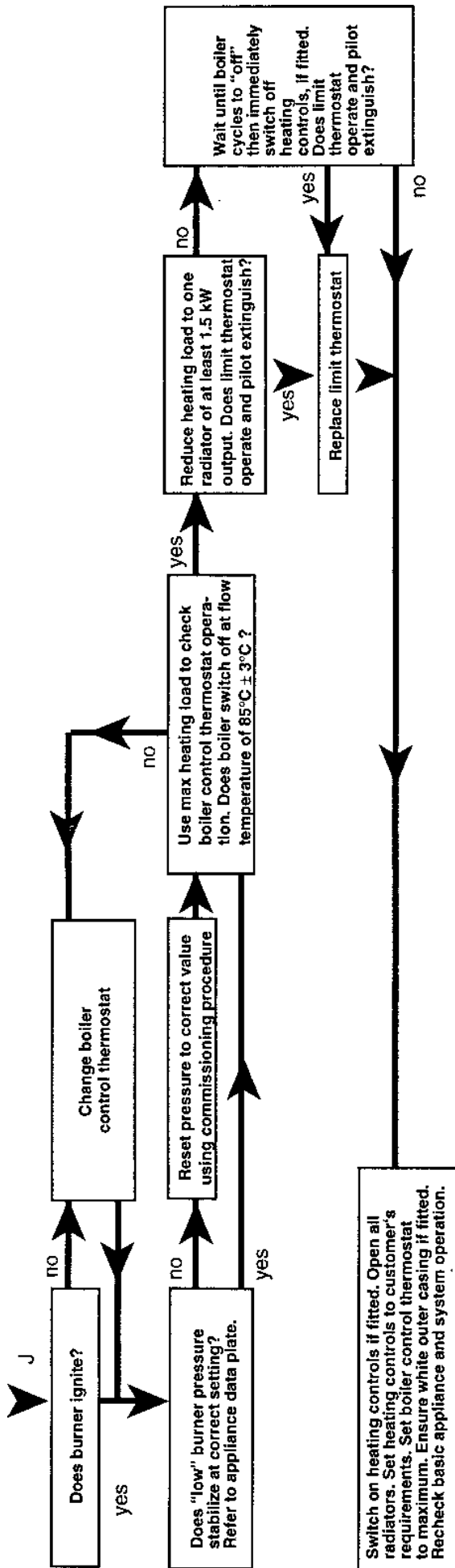






\* NOTE  
When DHW flow rate at the tap is 3 l/m (minimum) and depending on mains cold water inlet temperature, there may be insufficient heat input under "low" burner gas pressure to cause the burner to cycle on/off. The burner will cycle from "high" to "low". This is normal. In doubt follow both procedures ie. A followed by B.







Alpha Therm Limited.  
Goldsel Road, Swanley, Kent BR8 8EX  
Tel: (01322) 669443  
Fax: (01322) 615017  
email: [info@alphatherm.co.uk](mailto:info@alphatherm.co.uk)  
website: [www.alpha-boilers.com](http://www.alpha-boilers.com)

# **OCEAN** *Style* **OF**

**WALL MOUNTED, GAS FIRED COMBINATION  
BOILER FOR USE WITH NATURAL GAS ONLY**

## **OPERATING INSTRUCTIONS FOR THE USER**

Gas Safety (Installation and use) Regulations 1984:— It is the law that all gas appliances are installed by a competent person, in accordance with the above regulations. Failure to install appliances correctly could lead to prosecution. It is in your own interest, and that of safety, to ensure compliance with the law.

For Technical help or for Service call ...

**ALPHA HELPLINE**  
Tel: (01322) 669443

*Alpha*  
BOILERS

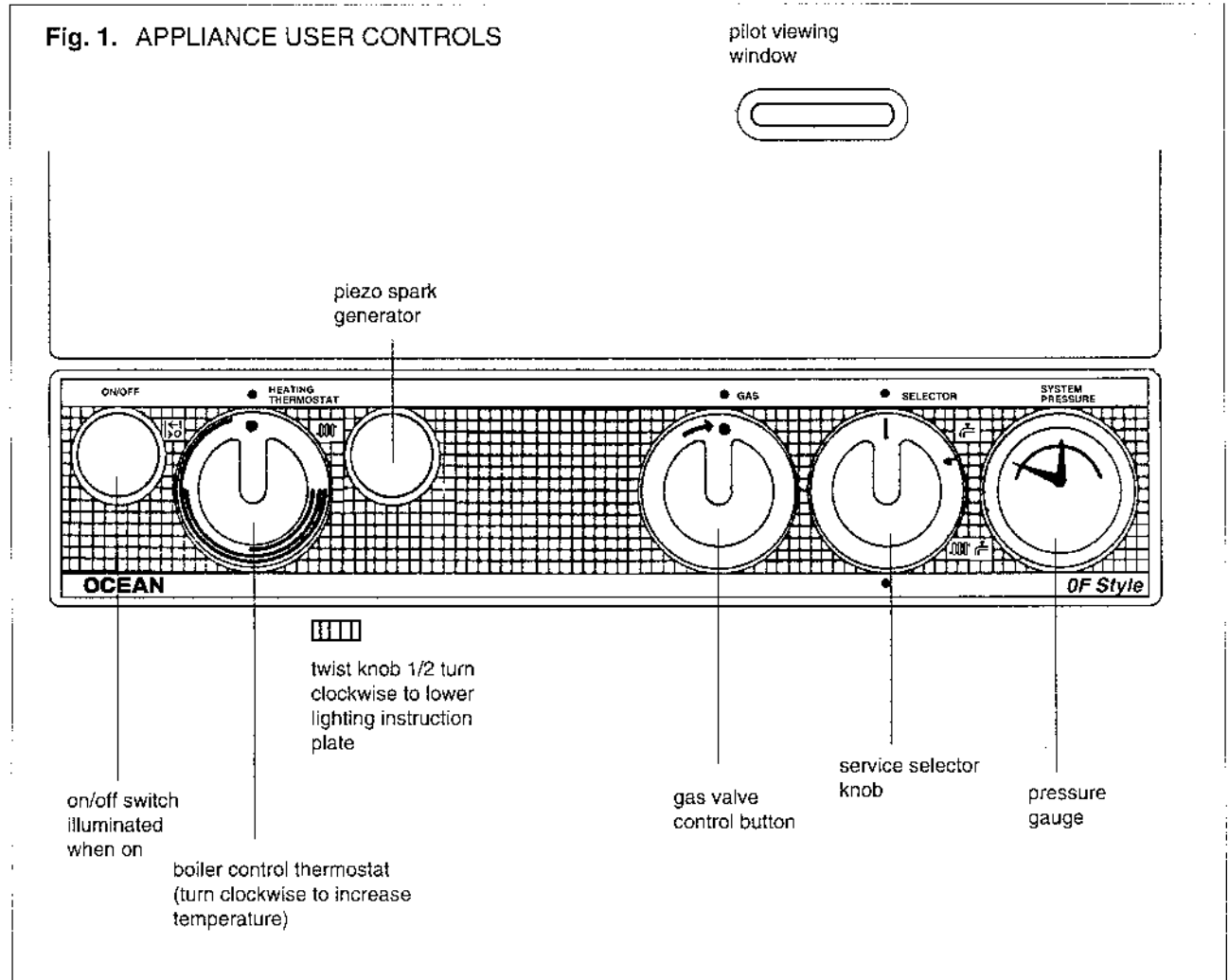
Goldsel Road,  
Swanley, Kent BR8 8EX  
Fax: (01322) 615017

## 1. DESCRIPTION OF THE APPLIANCE

The Ocean OF is a wall mounted gas fired combination boiler. It provides a domestic hot water and central heating service. When the central heating service is not required the appliance can be set by the user to provide domestic hot water only up to a maximum output of 23.4 kW (80,000 Btu/h). Hot water is made available almost instantaneously at the boiler but the final temperature and the time taken for hot water to reach a tap will depend upon the rate at which water is drawn off and the length of the service pipe between the appliance and a tap.

NOTE:- ADJUSTMENTS - SERVICING AND THE REPLACE-

MENT OF COMPONENT PARTS MUST BE CARRIED OUT BY A COMPETENT PERSON IN ACCORDANCE WITH THE GAS SAFETY (installation and use) REGULATIONS 1984. Within the boiler, the services of central heating and domestic hot water operate independently; when there is a demand for domestic hot water this takes priority. The services are controlled from a knob on the boiler control panel which may be set to domestic hot water only (summer condition) or domestic hot water and central heating (winter condition). Refer to Fig. 1



## 2. APPLIANCE METHOD OF OPERATION

When there is no demand for either domestic hot water or central heating the pilot remains alight permanently unless switched off by the user as described in section 4 paragraph 6. Any demand for domestic hot water will be sensed by detecting water flow through the boiler, provided the flow rate is above the minimum of 3 l/min (0.66 gpm). The boiler will fire to its full output. If the rate of draw off is near the maximum design flow rate of 9.6 l/m (2.1 gpm) the boiler will run continuously at full output until a tap is either turned off or the rate at which water is being drawn off is reduced. If the user selects domestic hot water and central heating and if all domestic taps are off and the heating clock and controls are calling for heat (refer below to section 3) the boiler will ignite to provide the preset central heating output. A control thermostat is provided to allow the user to regulate the boiler central heating water flow temperature. Adjustment is by

means of a knob on the boiler control panel (Fig. 1). Adjustment of the control thermostat knob does not affect domestic hot water temperature. The thermostat controlling domestic hot water temperature is not accessible to, or adjustable by, the user.

At intermediate draw off rates around 5 to 7 l/m (1.1 to 1.5 gpm) the boiler will usually cycle between its maximum output and whatever output has been set by the installer or run continuously at its low output until either a tap is turned off or the rate at which water is being drawn off is reduced.

At minimum draw off rate 3 l/m (0.66 gpm) the boiler will settle down to cycle ON/OFF.

Under these conditions water temperature at a tap would normally be around 40-45 °C at maximum rate (9.6 l/m - 2.1 gpm) and 75-80 °C at minimum flow rate (3 l/m - 0.66 gpm) depending on particular circumstances.

### 3. HEATING CONTROLS

The boiler is not provided with a heating timer or controls, other than the boiler control thermostat, with which to control heat output from the radiators.

The Installation, Commissioning and Servicing Instructions provide the installer with full details of how a heating timer and/or heating controls should be fitted.

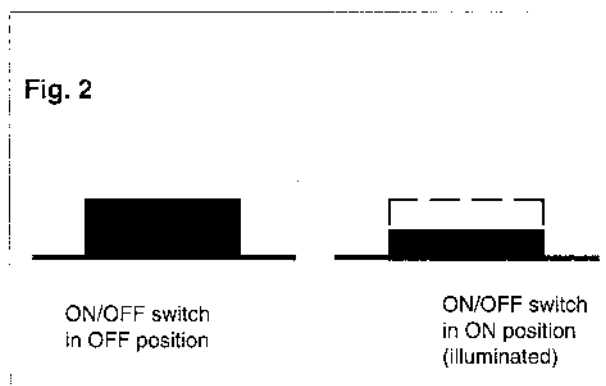
### 4. TO OPERATE THE APPLIANCE

Please ensure that the installer advises you on the correct operation of the appliance, system and any heating controls fitted.

1. Refer to Fig. 1. Switch off the mains electrical supply at the isolation switch or wall socket. Ensure any heating timer and/or heating controls, such as a room thermostat are in the OFF or MINIMUM position.

Make sure the ON/OFF switch at the boiler control panel is NOT ILLUMINATED and the switch is not depressed before proceeding (Fig. 2).

Ensure all water isolation valves are in the open position ie. slots in line with pipes.



2. Operate the boiler ONLY if it and the system has been fully charged to correct design pressure. Observe the pressure gauge. When cold this would read normally between 0.5 and 1.5 bar. If in doubt consult the installer as to the correct pressure when cold.

3. Turn the boiler control thermostat fully counterclockwise to the MINIMUM position. Grasp the gas valve ignition button and turn it clockwise a quarter of a turn against the spring pressure and release. Set the service selector knob to domestic hot water.

4. Turn ON a domestic hot water tap and ensure water flows freely.

Turn OFF the tap.

At intermediate draw off rates around 5 to 7 l/m (1.1 to 1.5 gpm) the boiler will usually cycle between its maximum output and whatever output has been set by the installer or run continuously at its low output

5. Switch ON the mains electrical supply at the isolation switch or wall socket. Ensure any heating timer and / or heating controls are ON or calling for heat and adjusted to the desired settings.

6. Depress and release the ON/OFF switch at the control panel to switch ON the electrical supply at the appliance. The switch will illuminate when power is ON. Depress fully the gas valve control button for 18-20 seconds and at the same time press the piezo spark generator (Fig. 1) The pilot will ignite. Continue to keep the gas valve control button depressed for a further 30-40 seconds. When the button has been released the pilot should remain alight. Observe the pilot through the pilot viewing window.

If the pilot does not remain alight, twist the gas valve control button in the direction of the arrow and release.

If the pilot is extinguished at this, or any other time, wait at least 3 minutes before attempting to relight

7. When the pilot remains alight, turn on a domestic hot water tap. The main burner should ignite. Turn OFF the tap. The burner should extinguish.

8. Set the service selector knob to hot water and central heating. Turn the boiler control thermostat clockwise to MAXIMUM. The burners should ignite.

If any heating timer is set to the OFF position or any room thermostat turned down to minimum (PROVIDED HEATING CONTROLS ARE FITTED) the burners should extinguish. The burners should re-ignite when the external controls are reset. Set the boiler control thermostat to the desired setting.

NOTE:- Whenever the service selector knob is in the hot water and heating position the hot water service takes priority.

Hot water will not be provided unless the draw off rate is at least 3 l/m (0.66 gpm). A hot water draw off rate on excess of 9 l/min from a single tap, or the operation of a number of taps will result in a reduced hot water temperature. Refer to section 2.

### 5. DATA PLATE AND LIGHTING INSTRUCTION PLATE

A data plate is positioned under the border, fixed to the main controls support plate.

Information on how to operate the appliance is provided on a hinged lighting plate under the main controls support plate. Twist the knob (Fig. 1) a quarter turn clockwise to lower the panel.

### 6. TO TURN THE CENTRAL HEATING SERVICE OFF

1. To turn the heating service OFF set the service selector knob to hot water only. See Fig. 1. To turn on the central heating services ensure all domestic hot water taps are off and set the service selector knob to central heating and hot water.

2. TO TURN OFF THE APPLIANCE FOR SHORT PERIODS. Set the service selector knob to hot water only. Ensure all domestic hot water taps are OFF. DO NOT turn off the electrical supply to the appliance at the ON/OFF switch.

3. TO TURN OFF THE APPLIANCE FOR LONG PERIODS.

Depress and release the ON/OFF switch.

Turn the gas valve ignition button in the direction of the arrow and release: the pilot should go out.

Isolate the electrical supply to the system and boiler by turning OFF the power supply at the wall socket or isolation switch.

When relighting follow the full operating procedure in Section 4. Consult the installer as to the need for protection against frost by means of a frost thermostat or night set back room thermostat.

### 7. SERVICING THE APPLIANCE

If the appliance is to maintain its efficiency and continue to operate with maximum safety, over a period of many years, routine annual servicing is essential.

For advice on servicing contact either the sole UK Agents, Argos Building and Heating Supplies Ltd or the local Gas Region.

## 8. GENERAL INFORMATION

1. Should a fault occur with the boiler control system, the appliance is fitted with an overheat thermostat which will shut down the supply of gas to the burners - including the pilot - independent of the normal control system.

If this fault occurs when the main burner is firing or if the pilot flame continually requires relighting after following the procedure under Section 4 contact whosoever is routinely servicing the appliance.

2. In the event of the failure of the electrical supply to the appliance the pilot should remain alight.

Note: Depending on the conditions prevailing when power is interrupted it may be necessary to reset the gas controls and relight the pilot when power is restored. (Section A).

Normally the boiler will reignite automatically when power is restored if any heating timer or heating controls fitted are ON and calling for heat. Remember to reset any heating timer fitted whenever there has been either a power supply failure or the electrical supply to the appliance has been interrupted at the isolation switch or wall socket.

3. If the mains water supply fails or is turned off for any reason there can be no hot water service from the appliance until the supply is restored. The boiler may be operated to provide a central heating service. If supply pressure varies or is low - minimum 0.5 bar. (7.3 psi) - it may not be possible to turn on all hot water taps simultaneously and achieve a reasonable flow rate.

4. If the temporary hardness of the water supply to the appliance is in excess of 150 parts per million the fitting of an "in line" scale inhibitor is recommended. The local Water Undertaking will usually provide information and give advice in these matters.

5. The appliance functions as a natural open flue unit. Under no circumstances should the flue discharge terminal be obstructed. If damaged turn off the appliance and contact the installer / Gas

Region.

6. Minimum clearances around the appliance must be maintained if the appliance is to operate safely and routine servicing is to be undertaken.

POSITION	MINIMUM CLEARANCE REQUIRED
Above	270 mm (10.6 in)
Below	270 mm (10.6 in)
L.H. side	30 mm (1.2 in)
R.H. side	30 mm (1.2 in)
In front	450 mm (18 in)

7. If the appliance has been installed within a cupboard or compartment high and low level ventilators will have been provided by the installer in accordance with the Installation, Commissioning and Servicing booklet included with the appliance. The ventilators **MUST BE KEPT FREE FROM OBSTRUCTION AT ALL TIMES**. The cupboard or compartment containing the boiler **MUST NOT BE USED FOR THE STORAGE OF OTHER ARTICLES**.

8. Ancillary equipment for use with the appliance such as mixing valves, showers, bidets etc. **MUST** be designed to operate at mains water pressure. General advice is given to the installer, relating to the installation and use of the above equipment, in the appliance Installation, Commissioning and Servicing Instructions. However, the local Water Undertaking should be contacted for specific information and requirements before fitting.


9. Use only a damp cloth and mild detergent to clean the appliance outer casing. **DO NOT** use abrasive cleaners.

## 9. ELECTRICAL SUPPLY

If a mains plug connection is used, it **MUST** be a 3-pin type, wired as shown in Fig. 3, and fused at 3 Amp.

**The appliance MUST be efficiently earthed.**

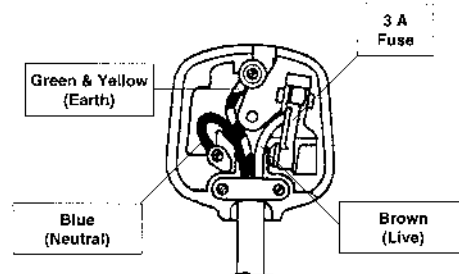
As the colour of the wires in the mains lead of this appliance may not correspond with the coloured markings identifying the terminals in your plug, proceed as follows: -

The wire which is coloured GREEN and YELLOW must be connected to the terminal in the plug with the letter E or by the earth symbol  or coloured GREEN or GREEN and YELLOW.

The wire which is coloured BLUE must be connected to the terminal which is marked with the letter N or coloured BLACK.

The wire which is coloured BROWN must be connected to the terminal which is marked with the letter L or coloured RED.

FIG 3. THREE-PIN PLUG (TO BS.1363)



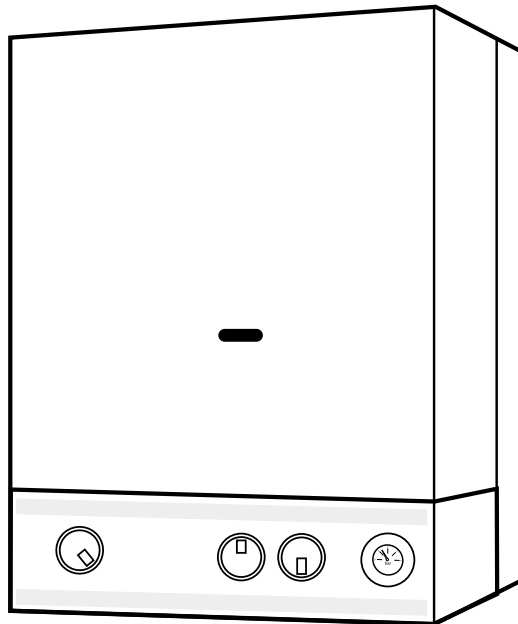
Supply: 240 V, 50 Hz fused at 3 amps

### WARNING

**IF A GAS LEAK IS SUSPECTED OR EXISTS TURN OFF THE GAS SUPPLY TO THE APPLIANCE AT THE GAS SERVICE COCK. DO NOT TOUCH ANY ELECTRICAL SWITCHES TO TURN THEM EITHER ON OR OFF. DO NOT OPERATE ANY ELECTRICAL APPLIANCE. OPEN ALL WINDOWS AND DOORS. DO NOT SMOKE. EXTINGUISH ALL NAKED LIGHTS. CONTACT THE LOCAL GAS REGION IMMEDIATELY.**

**Alpha**  
BOILERS

Alpha Therm Limited.  
Goldsel Road, Swanley, Kent BR8 8EX  
Tel: (01322) 669443  
Fax: (01322) 615017  
email: info@alphatherm.co.uk  
website: www.alpha-boilers.com



# ***SPARE PARTS LIST***

**For**  
**Ocean Style 80 FF and Style 80 OF**  
**gas fired Combination boilers**

**British Gas GC Number:-**

**Ocean Style 80 FF 47 532 02**

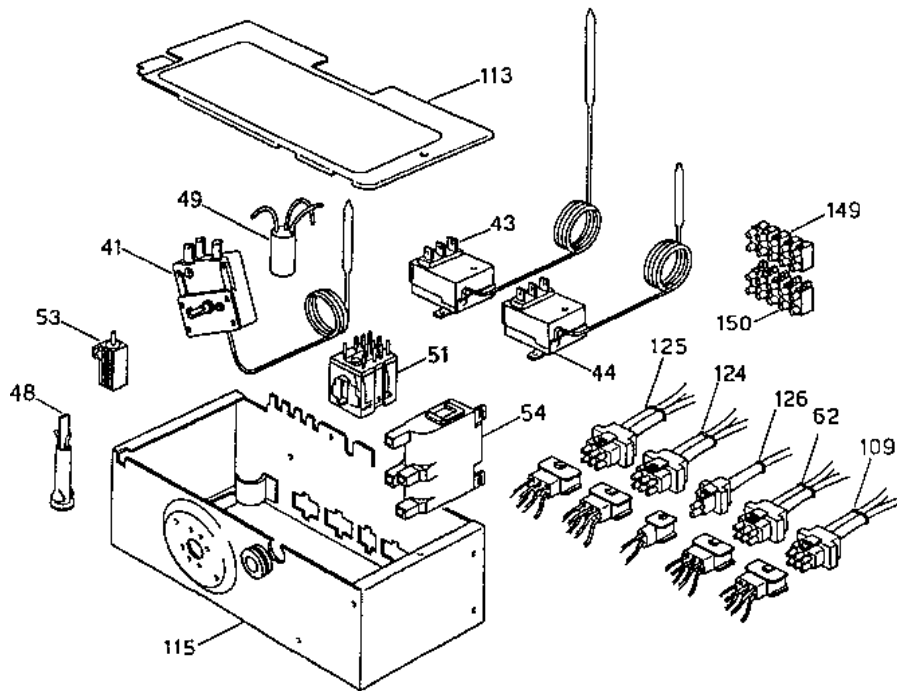
**Ocean Style 80 OF 47 532 03**

**August 2002**

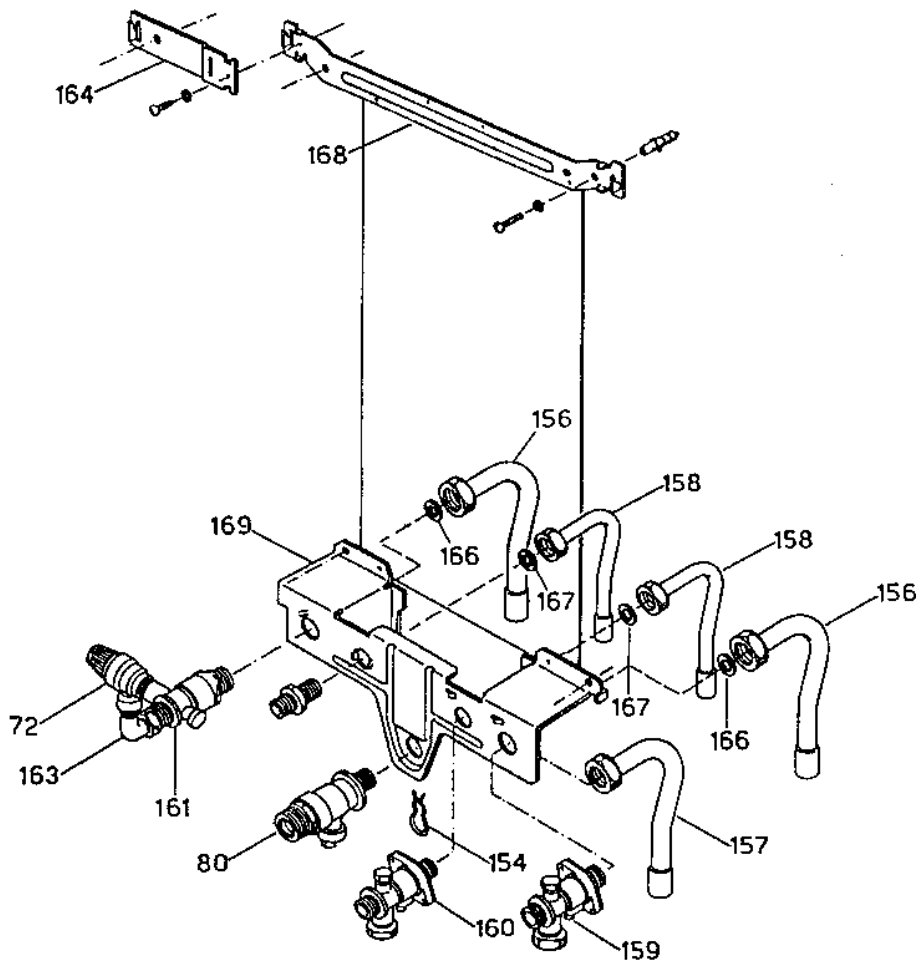




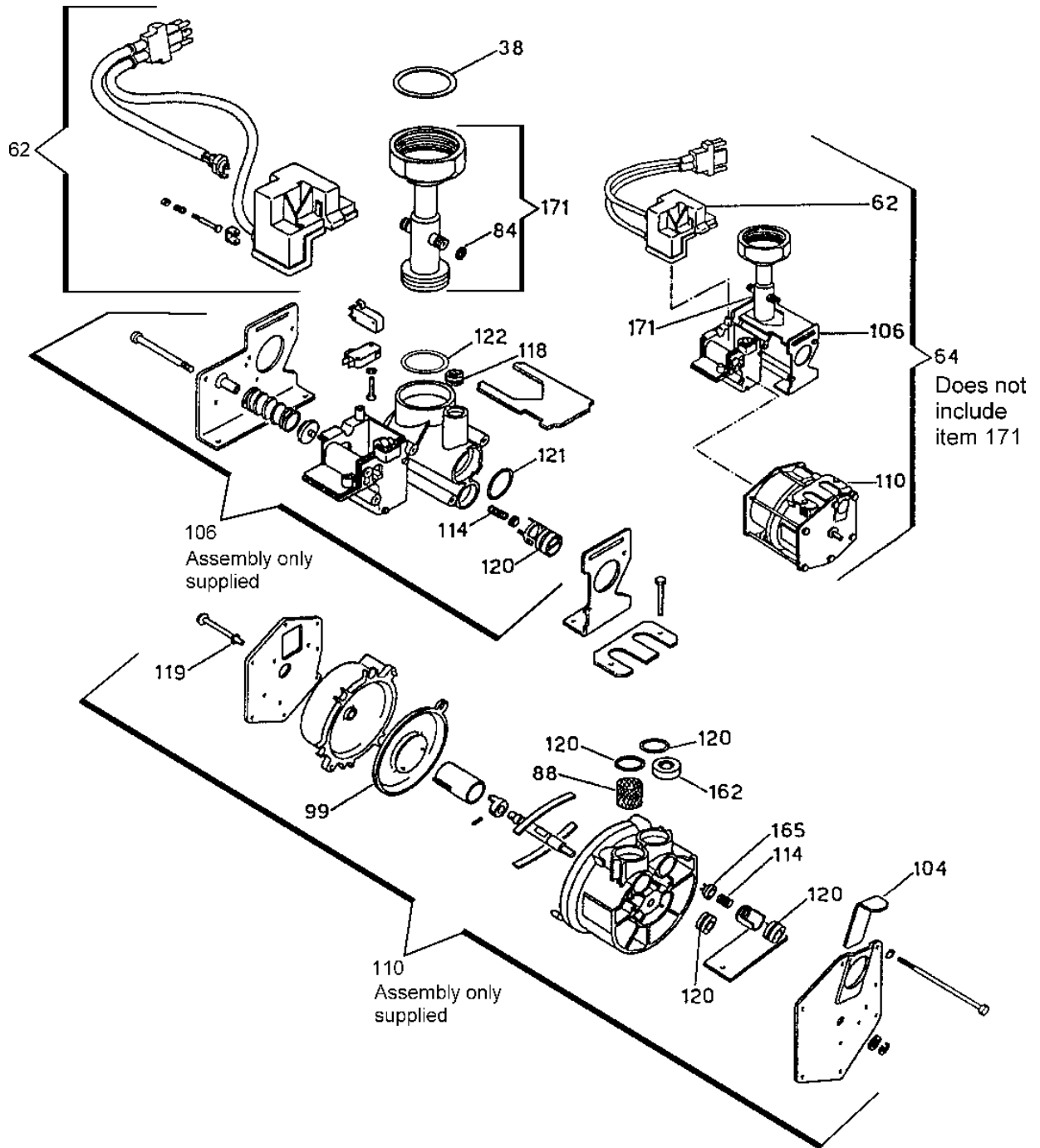
## Style - Control box



## Connection pipework



# 3-way valve



Ref No.	Ocean Style 80 FF	Ocean Style 80 OF	Description
1	6.5615061	6.5615061	Burner assembly
17-31	6.5209150	6.5209150	Main burner injector 1.18 mm (NG)
-	6.5605791	6.5605791	Injector manifold with injectors (NG)
32	6.5615071	6.5615071	Gas valve (NG) with control knob
32	6.5618891	-	Gas valve (LPG) with control knob
33	6.5604732	6.5604732	Pilot burner c/w injector 0.27 mm (NG)
34	6.5201550	6.5201550	Pilot injector 0.27 mm (NG)
35	6.8413451	6.8413451	Electrode lead
36	6.8420930	6.8420930	Electrode
37	6.5611791	6.5611791	Pump
38	6.1000710	6.1000710	Washer - pump connections (part of seal kit)
39	6.5607294	-	Fan
40	6.1000730	-	External flue turret gasket (part of seal kit)
40	6.1000730	-	Internal flue turret gasket (part of seal kit)
41	6.8432322	6.8432322	Heating thermostat
42	6.5616401	6.5616401	Heating thermostat knob
43	6.8433431	6.8433431	Safety limit thermostat
44	6.8433421	6.8433421	Hot water thermostat
45	6.5614712	6.5614712	Overheat thermostat with leads
46	6.5614721	6.5614721	Thermocouple
47	6.5202491	6.5202491	Thermocouple connector
48	6.8421751	-	Green LED indicator
48	-	6.8432991	On/Off switch
49	6.8450191	6.8450191	Capacitor
50	6.5401652	-	Pilot tube sealing gasket
50	-	6.5624600	Draught diverter
51	6.5632710	-	Relay
51	-	6.5618061	Lower plastic panel
52	-	6.5618601	Aluminium drip tray
53	6.8432941	-	Fan speed resistor
54	6.5607310	-	Spark ignition generator
55	6.5617551	-	Air pressure switch
56-57	6.5614801	-	Ignition microswitch with lead and plug
58	6.5635010	6.5635010	Water flow switch
60	6.5610362	6.5610362	DHW heat exchanger
62	6.5617081	6.5617081	Microswitch assembly (3-way valve)
64	6.5623431	6.5623431	3-way valve complete
66	6.5618331	6.5618331	Summer/winter knob
67	6.5606221	6.5606221	Expansion vessel
68	6.5624241	6.5624241	DHW shock arrester
70	6.5617451	6.5617441	Main heat exchanger
72	6.5608551	6.5608551	3 bar pressure relief valve
73-77	6.5614731	6.5614731	Combustion chamber insulation panel set
80	6.5614281	6.5614281	Gas service cock
81	6.1000725	6.1000725	'O' ring seal 28.24 x 2.62 (part of seal kit)
82	6.1000730	-	'O' ring seal 92 x 3 (part of seal kit)
82	-	6.8433221	Spark generator
84	6.1000715	6.1000715	Pressure gauge washer (part of seal kit)
85	6.8922330	6.8922330	Pressure gauge
87	6.5614851	6.5614851	Pilot supply tube
88	6.5102271	6.5102271	Water filter - 3-way valve

Ref No.	Ocean Style 80 FF	Ocean Style 80 OF	Description
91	6.5600731	6.5600731	Automatic air vent
92	6.5607482	-	Sealed chamber front panel
93	6.5103360	-	Pilot glass retaining plate
94	6.5203930	-	Pilot glass
95	6.5401610	-	Pilot glass gasket
97	6.5619031	-	Rear support frame
98	6.5105741	-	Outer case securing bracket
99	6.1000710	6.1000710	Main diaphragm (part of seal kit)
100	6.5610941	6.5610941	Mains water inlet pipe
101	6.5201351	6.5201351	Brass cap - 1/2" BSP
102	6.5613911	-	Sealed chamber top panel
103	6.5615352	6.5615352	Control box right hand side panel
103	6.5615362	6.5615362	Control box left hand side panel
105	6.5202271	-	Air pressure switch tube
106	6.5630531	6.5630531	3-way valve body only
107	6.5607391	6.5607391	Expansion vessel connection pipe
108	6.5622132	-	Control panel (clock option)
108	-	6.5621161	Control panel
110	6.5623410	6.5623410	DHW priority pressure sensor
111	6.5610161	6.5610161	Flow switch connection pipe
112	6.5622332	-	Electric control box (complete)
116	6.8100872	-	Sealed chamber front fixing screw
117	6.5610663	6.5610663	Gas valve support cross member
118	6.1000710	6.1000710	'O' ring restrictor by-pass (part of seal kit)
119	6.1000710	6.1000710	'O' ring cover sensor pivot - 3-way valve (part of seal kit)
120	6.1000710	6.1000710	'O' ring 13.94 x 2.62 - 3-way valve (part of seal kit)
121	6.1000710	6.1000710	'O' ring 22 x 3 - 3-way valve (part of seal kit)
122	6.1000710	6.1000710	'O' ring 3-way valve pipe (part of seal kit)
123	6.5639230	-	Flue venturi
-	6.5402050	-	Flue venturi gasket
-	6.5206212	-	Flue venturi hose adapter
124	6.8414941	-	Cable - Gas valve and water flow sensor
125	6.8415141	-	Cable - Fan/air pressure switch
126	6.8412882	-	Cable - Pump
127	6.8100611	6.8100611	Screw - Heating thermostat
129	6.8101181	6.8101181	Screw M5 x 10
130	6.8142431	-	Screw - Fan mounting plate
131	6.8100572	-	Screw
132	6.5101841	6.5101841	Pipe retaining plate - 3-way valve
133	6.5610751	6.5610751	DHW heat exchanger guiding plate - right
134	6.1000725	-	Grommet - Gas pipe through sealed chamber (part of sela kit)
135	6.5613921	-	Flue hood
136	6.1000700	-	'O' ring - Primary pipe to heat exchanger (part of seal kit)
137	6.5615441	6.5615441	Gas inlet pipe
138	6.5615201	-	RS chamber right side panel
139	6.5615191	-	RS chamber left side panel
140	6.5102412	-	Combustion chamber front panel
141	6.5614731	6.5614731	Insulation panel set
142	6.5400861	6.5400861	Gas valve control knob body
143	6.5616411	6.5616411	Gas valve control knob top

<b>Ref No.</b>	<b>Ocean Style 80 FF</b>	<b>Ocean Style 80 OF</b>	<b>Description</b>
144	6.1000700	-	Washer 18.5 wrc - main heat exchanger (part of seal kit)
145	6.5610741	6.5610741	DHW heat exchanger guiding plate - left
146	6.5622671	6.5622671	DHW H/Ex to 3-way valve connecting pipe
148	6.5622121	-	Blanking plate
149	6.8421721	-	Terminal block (male)
150	6.8421711	-	Terminal block (female)
151	6.5622424	-	Plastic controls cover (complete)
152	6.5109031	6.5109031	White underside guard
153	6.5401901	6.5401901	Hinge
154	6.5102691	6.5102691	Clip ¾"
155	6.5102701	6.5102701	Clip ½"
156	6.5615531	6.5615531	Heating flow /return elbows - 18 mm
157	6.5615521	6.5615521	Gas inlet elbow - 18 mm
158	6.5615541	6.5615541	DHW inlet/outlet elbows - 14 mm
159	6.5621431	6.5621431	Heating return isolating valve
160	6.5626412	6.5626412	Mains inlet water isolating valve
161	6.5613691	6.5613691	Heating flow isolating valve
162	6.5622681	6.5622681	DHW flow restrictor
163	6.5610111	6.5610111	Heating flow isolating valve - elbow only
164	6.5610701	6.5610701	Wall mounting plate extension c/w screws/plugs
166	6.1000720	6.1000720	Washer 18.5 wrc (part of seal kit)
167	6.1000720	6.1000720	Washer 14.5 wrc (part of seal kit)
170	6.5615241	-	Gas valve to manifold pipe
171	6.5610181	6.5610181	Pump to 3-way valve connecting pipe
172	6.5615311	6.5615311	DHW outlet connection pipe
173	6.5617250	6.5617951	Heat exchanger primary return pipe
174	6.5608363	6.5608363	Heating return pipe to isolating valve
175	6.5204002	-	Fan flange
176	6.5103583	-	Fan mounting plate
177	6.5622591	-	Flue turret
178	6.5615291	6.5617961	Heat exchanger primary flow pipe
179	6.5605911	6.5605911	Heating flow connection pipe
180	6.5203191	6.5203191	3-way valve by-pass pipe to DHW heat exchanger
182	6.5101181	-	Screw for aluminium pipe
183	6.5401732	-	Air duct locking ring
184	6.5616011	-	Aluminium flue duct
185	6.5403591	-	Plastic air duct
186	6.8100742	-	Terminal screw
187	6.1000350	-	Sealing collar
189	6.5206341	-	Flue terminal
-	6.5105792	6.5617331	Outer casing
-	6.8100572	-	Screw (casing)
-	6.5652030	6.5652030	Drain tap
-	6.0001143	6.0001143	Domestic hot water shock arrestor kit
			SEAL KITS
195	6.1000700	6.1000700	Seal kit 700 - Water complete
200	6.1000705	6.1000705	Seal kit 705 - DHW heat exchanger
205	6.1000710	6.1000710	Seal kit 710 - 3-way valve
210	6.1000715	6.1000715	Seal kit 715 - Main heat exchanger
215	6.1000720	6.1000720	Seal kit 720 - Wall plate

Ref No.	Ocean Style 80 FF	Ocean Style 80 OF	Description
220	6.1000725	6.1000725	Seal kit 725 - Gas complete
225	6.1000730	-	Seal kit 730 - Flue turret
			LITERATURE
230	6.9169282	6.9170961	Installation instructions
235	6.9169351	6.9166871	User instructions

**Alpha**  
BOILERS

Alpha Therm Limited.  
Goldsel Road, Swanley, Kent BR8 8EX  
Tel: (01322) 669443  
Fax: (01322) 615017