

# ***Ocean Style FF*** APPLIANCE CATEGORY 1 N **N**

**WALL MOUNTED, GAS FIRED COMBINATION  
BOILER FOR USE WITH NATURAL GAS ONLY**

## **INSTALLATION, COMMISSIONING AND SERVICING INSTRUCTIONS**

Gas Safety (Installation and use) Regulations 1984:- It is the law that all gas appliances are installed by a competent person, in accordance with the above regulations. Failure to install appliances correctly could lead to prosecution. It is in your own interest, and that of safety, to ensure compliance with the law.

The installation of this appliance must be in accordance with the relevant requirements of the Gas Safety (Installation and use), 'Current' IEE Wiring Regulations, local building regulations and bye laws of the local water undertaking. It should be in accordance also with the relevant recommendations of the following British Standards and Codes of Practice: CP.331-3, BS 5449:1:1977, BS. 5546:1:1979, BS. 5440:1:1990, BS. 5440:2:1989, BS. 6798:1987, BS. 6891:1988 and BG. DM2

Manufacturer's instructions must NOT be taken in any way as over-riding statutory obligations.

For Technical help or for Service call ...

**ALPHA HELPLINE**  
Tel: (01322) 669443

**Alpha**  
BOILERS

Goldsel Road,  
Swanley, Kent BR8 8EX  
Fax: (01322) 615017

# CONTENTS

<b>INTRODUCTION</b>		
1.	General Specification Details	Page 4
2.	External Heating Controls	4
3.	Electrical Supply	4
4.	Packaging	4
<b>GENERAL INFORMATION</b>		
	Technical Data - Tables 1 and 2	5
	Flue Details - Table 3	5
	Available Pump Heads - Table 4	6
<b>INSTALLATION INSTRUCTIONS</b>		
1.	Gas Supply	6
2.	Location of Boiler	6
3.	Flue Position	7
4.	Air Supply - Fig. 2 Tables 5 and 6	7
<b>REQUIREMENTS FOR SEALED SYSTEMS</b>		
1.	General	8
2.	Pressure Gauge	8
3.	Safety Valve	8
4.	Pump	8
5.	Expansion Vessel	8
6.	System Volume - Table 7	8
7.	Filling and Venting the System	8
8.	System Checks - Fig. 3	9
<b>DOMESTIC HOT WATER SUPPLY TO THE BOILER AND OTHER APPLIANCES</b>		
1.	General	10
2.	Bidets	10
3.	Showers	10
4.	Domestic Hot and Cold Water Supply Taps and Mixing Valves	10
5.	Domestic Expansion Vessel	10
<b>REQUIREMENTS FOR ELECTRICAL WIRING</b>		
1.	General Safety	10
2.	Mains Supply Wiring to the Appliance - Fig. 4	10
	Clock Installation (Optional)	11
3.	External Wiring of Heating Controls. Clock - Room Thermostat - Frost Thermostat - Fig. 5	13
	Appliance Wiring Diagram - Fig. 6	13
	Appliance Functional Flow Diagram - Fig. 7	14
<b>INSTALLATION OF THE APPLIANCE</b>		
1.	Fixing Templates - Hardware Supplied	15
2.	Fixing the Wall Mounting Plate	15
	Dimensional Relationship Between Appliance and Wall Face - Wall Mounting Requirements - Assembly of Upper Cross Bar	15
3.	Preparation of Air/Flue Duct. Standard Flue Kit - Rear - Right/Left Hand Outlets	15
	Air/Flue Duct Connections - Flue Terminal Assembly Detail - Flue Connection Detail - Fig. 9	
4.	Installing the Air/Flue Duct - Standard/Extension Kits - Rear - Right/Left Hand Outlets	17
	Extension Duct Kit Assembly - Rear - Right/Left Hand Outlets - Fig. 11	19
5.	Making Service Connections, from the System to the Wall Plate	20
6.	Hanging the Boiler on the Wall Plate and Making Service Connections to the Boiler - Fig. 12	20
7.	Commissioning the Appliance. Checks for Gas Soundness - Purging. Filling the System - Flushing.	21
	Control Panel - User Controls - Fig. 14.	
	Pilot Supply Pipe - Gas Soundness Check - Adjustment of Pilot Flame - Fig. 15	
	Procedure for Setting Central Heating and Domestic Hot Water Gas Pressure	
8.	Checking Operation of the Central Heating / Domestic Hot Water Services / Safety Valve	23
	Central Heating / Domestic Hot Water Bypass Adjustment. Final Adjustments and Requirements	23
9.	Instructions Provided for the User. Users Instruction Literature. Servicing Intervals.	

# CONTENTS CONTINUED

	Page
<b>SERVICING THE APPLIANCE</b>	24
1. Annual Servicing - Routine Inspection and Cleaning	24
2. Checks Undertaken Prior to Servicing	25
3. Tools Required - Basic List	25
4. Servicing of Components	25/26/27
Specific order of removal for servicing - and reassembly	26
5. Replacement of Component Parts	27
Replacement of Components - Index.	27
Replacement of thermocouple; Electrode lead; electrode; pilot injector; pilot burner bracket assembly with shield; synthetic rubber sealing gasket; fan; main burner; injectors; viewing window.	27/28/29
Replacement of control box components; Suppressor.	28
Replacement of relay/Fan resistor; Clock replacement	29
Control Thermostat; Safety Thermostat; domestic hot water thermostat.	29
Replacement of Overheat Thermostat	30
Replacement of Air Pressure Switch; Ignition Control Microswitches	30
Replacement of Gas Valve	31
Replacement of Boiler Combustion Chamber insulation	32
Replacement of components requiring isolation of the appliance from the central heating (PRIMARY) and domestic hot water (SECONDARY) circuits and draining down the system: - Water Flow Switch Circulating Pump or Circulating Pump Motor.	33
Replacement of Domestic Hot Water Heat Exchanger	33/34
Replacement of microswitch cover assembly - domestic hot water pressurestat and diverter valve	34
Replacement of Expansion vessel	35
Replacement of Safety Valve; Stainless steel Domestic Hot Water pressure vessel; Pressure gauge.	36
Replacement of boiler heat exchanger	37/38
6. BALANCED FLUE TERMINAL GUARD - SUPPLIERS AND FIXING (FIG. 47)	38
7. SHORT PARTS LIST AND PHOTOGRAPH OF COMPONENT PARTS	39
8. FAULT FINDING	40
	43

# INTRODUCTION

## 1 General Specification Details

The Ocean Style FF is a wall mounted, fan assisted room sealed combination boiler. Heat output is controlled through a HIGH/LOW gas valve fitted with permanent pilot.

The appliance is range rated to provide central heating outputs (LOW GAS VALVE ADJUSTMENT) between 17.6 kW (60,000 Btu/h) and 11.7 kW (40,000 Btu/h). Domestic hot water service (HIGH GAS VALVE PRESETTING) has priority at all times, and instant hot water is available at the boiler hot water flow outlet up to a maximum of 23.4 kW (80,000 Btu/h). Control over hot water output is achieved using the HIGH/LOW operation of the gas valve, ie. at a predetermined maximum hot water temperature the heat output will commence to switch between HIGH and the LOW setting used for heating.

The boiler is designed for use with fully pumped, open vent, sealed and pressurised heating systems using ONLY NATURAL GAS. The appliance IS NOT SUITABLE for providing domestic hot water WITHOUT CONNECTION to a HEATING SYSTEM.

The Ocean Style FF is supplied with domestic hot water calorifier, diverter valve, circulating pump, pressure gauge, safety valve, and sealed system expansion vessel.

Within the boiler the functions of heating and domestic hot water operate separately; when there is a domestic hot water demand this takes priority. The functions are controlled from a knob on the control panel which may be set to Domestic Hot Water only (summer condition), or Domestic Hot Water and Heating (winter condition). A demand for domestic hot water is sensed in the boiler by detecting domestic hot water flow. This switches on the boiler at HIGH gas valve setting. The boiler switches from HIGH to LOW and LOW to OFF to achieve control of water outlet temperature. When there is no domestic water demand and when the external controls (eg room thermostat and timeswitch) call for heating then the boiler delivers heating at the required heat output set when commissioning. The central heating (LOW gas valve adjustment) output is preset at 14.06 kW (48,000 Btu/h).

When domestic hot water temperature is below 65 °C the boiler fires at HIGH setting. Above 65 °C the gas valve switches to LOW

setting. If water draw off rate is low - minimum 3l/m (0.66 gpm) - the water temperature may rise up to a maximum of 80 °C before the boiler switches off. At high domestic water flows the delivery temperature will fall.

The boiler is supplied with a standard flue kit suitable for up to 750 mm (29.5 in) of flue installed with a right hand, left hand on rear outlet. Extension flue kits can be supplied as optional extras allowing the flue length to be increased up to a maximum of 4.5 metres (177.1 in) - five kits in total.

Optional extras to flueing include bends 90°, 45° offsets and vertical terminals - see table 3 General Information.

## 2 External Heating Controls

Provision is made at the boiler terminal strip for the connection of a heating time clock and room thermostat if clock option is not fitted. Thermostatic radiator valves may be used providing either a 22 mm by pass, with lockshield balancing valve, is fitted to ensure a minimum flow rate through the boiler of 9.86 l/m (2.17 gpm) when all radiator valves are closed. OR a single uncontrolled radiator with a minimum catalogue emission of 1.2 kW (4,100 Btu/h) is fitted.

## 3 Electrical Supply

The appliance is suitable for operation with a mains supply of 240 V ~ 50 Hz.

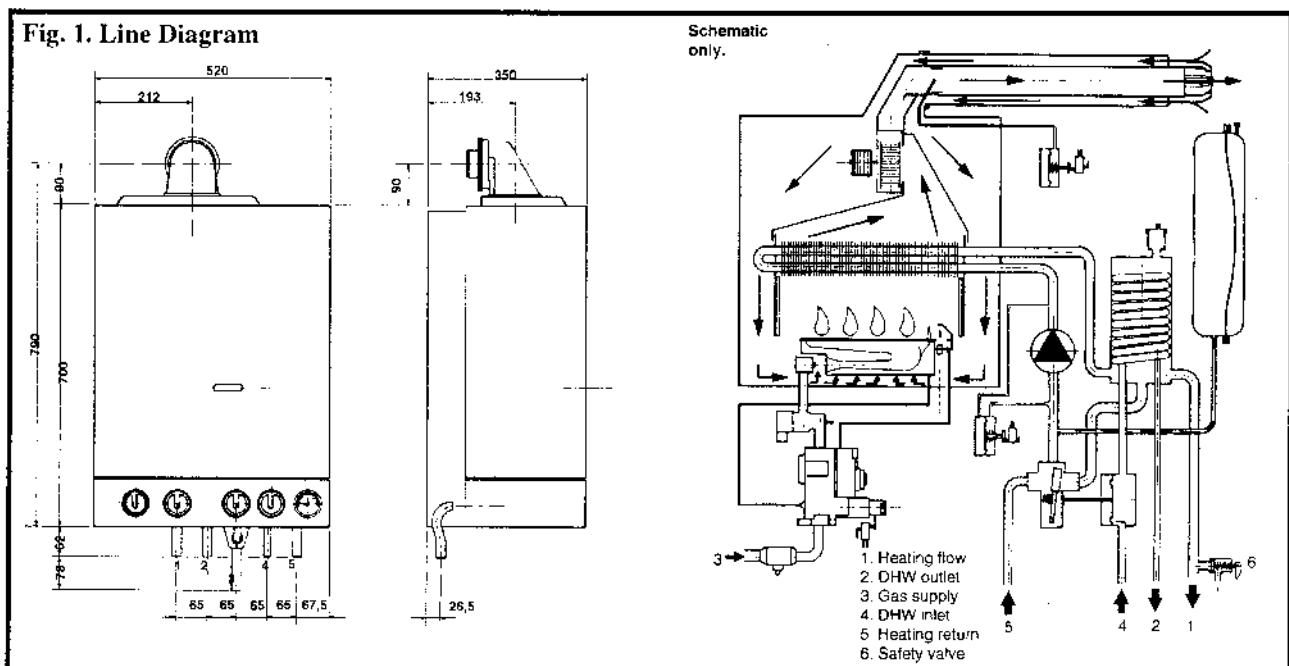
NOTE: The supply should be taken from an unswitched shuttered socket. The connection shall be adjacent to the appliance by means of a 3 pin plug, fused at 3 A. The plug and socket shall comply with BS 1363. Alternatively a double pole isolation switch MUST be used.

NOTE: If the electrical supply to the appliance is interrupted when the burner is firing it may be necessary, depending upon the particular operating condition, to reset the gas controls.

## 4 Packaging

The appliance is supplied in three cartons.

- The largest carton contains the boiler and literature.
- The smallest carton contains the wall mounting plate, fittings and other hardware.
- A carton containing the standard flue kit.



# GENERAL INFORMATION

## Technical Data

Note: - The appliance data plate is positioned under the boiler on the controls support plate

Table 1

NOMINAL BOILER RATINGS AT NORMAL OPERATING TEMPERATURE (10 minutes after lighting)								
OPERATION	OUTPUT		INPUT		BURNER SETTING PRESSURE		GAS RATE	
	kW	(Btu/h)	kW	(Btu/h)	mbar	(in.wg)	m <sup>3</sup> /h	(ft <sup>3</sup> /h)
CENTRAL HEATING OUTPUT (also the low DHW setting)	17.6	60,000	23.1	78,840	8.4	3.4	2.14	75.7
	16.1	55,000	21.5	73,380	7.2	2.9	1.99	70.4
★ INITIAL FACTORY SETTING	★ 14.1	48,000	19.2	65,530	5.7	2.3	1.78	63.0
	11.7	40,000	16.5	56,310	4.1	1.6	1.53	54.2
WATER ONLY	★ 23.4	80,000	29.7	101,370	13.9	5.6	2.76	97.7

NOTE:- A minimum gas supply pressure of 20 mbar (8 in wg) is required at the appliance inlet pressure test point.

NOTE:- The inlet Pressure test point is located on the gas valve (Refer to Fig. 15).

Table 2 (Refer to Fig. 1)

SPECIFICATIONS	
CENTRAL HEATING FLOW	22 mm COPPER
CENTRAL HEATING RETURN	22 mm COPPER
COLD WATER MAINS INLET	15 mm COPPER
DOMESTIC HOT WATER OUTLET	15 mm COPPER
GAS INLET	22 mm COPPER
SAFETY VALVE	15 mm COPPER
HEIGHT TO TOP OF JACKET	700 mm (27.6 in)
HEIGHT OVERALL	840 mm (33.5 in)
WIDTH	520 mm (20.5 in)
DEPTH	350 mm (13.8 in)
WEIGHT	42.5 kg (93.7 lbs)
PRIMARY CAPACITY	2.7 Litres(0.59 galls)
BURNER	OCEAN. 15 REMOVABLE BLADES WITH INDIVIDUAL INJECTORS
MAIN INJECTORS	OCEAN. 15 N° x 1.18 mm
PILOT INJECTOR	SIT 0.27 mod 0.140
IGNITION	HT SPARK - MAINS VOLTAGE TRANSFORMER OPERATED BY MANUAL PUSH BUTTON
CONTROLS AND IGNITION COMPONENTS	SEE SHORT PARTS LIST
MAXIMUM GAS CONSUMPTION	2.76 m <sup>3</sup> /h (97.7 ft <sup>3</sup> /h)
INTEGRAL EXPANSION TANK CAPACITY	7 Litres (1.5 gal) PRECHARGED TO 0.5 bar (7.3 psi)
MAINS SUPPLY VOLTAGE	240 V ~ 50 Hz FUSED AT 3 A
MAXIMUM POWER CONSUMPTION	190 W
MAXIMUM WATER PRESSURE IN HEATING CIRCUIT	3 bar (43.5 psi)
MAXIMUM CENTRAL HEATING FLOW TEMPERATURE	85°C (185°F) APPROXIMATELY *
MAXIMUM INLET DOMESTIC HOT WATER PRESSURE	8 bar (116 psi)
MINIMUM INLET DOMESTIC COLD WATER PRESSURE	0.8 bar (11.68 psi)
MINIMUM FLOW RATE OF DOMESTIC HOT WATER	3 l/min (0.66 gpm)
DOMESTIC HOT WATER FLOW RATE AT 45°C AND 10°C INLET WATER TEMPERATURE (35 °C RISE)	9.6 l/min (2.1 gpm)
MINIMUM FLOW RATE REQUIRED THROUGH BOILER CIRCULATING PUMP	9.86 l/min (2.17 gpm) HEATING MODE EURAMO GOLDSTAR GRUNDFOS UPS 15-60

\* The boiler control thermostat is intended to operate at a nominal maximum boiler flow temperature of 85°C (185°F)

Table 3

### FLUE DETAILS (see note below)

WALL HOLE DIAMETER FOR AIR DUCT	110 mm	4.5 in
MINIMUM FLUE LENGTH STANDARD FLUE	114 mm	4.5 in
MAXIMUM FLUE LENGTH STANDARD FLUE	750 mm	29.5 in

#### Optional Extras

Maximum flue length using 5 extension kits 4500 mm (177.1 inches) 90° bends 45° bends

#### Offsets

Vertical flue (maximum length 3.5 m (137.8 inches)

Note: - See instructions for bends, offsets and vertical flues for maximum permitted flue lengths

Table 4

AVAILABLE PUMP HEADS FOR HEATING SYSTEM						PRESSURE LOSS THROUGH BOILER FLOW-RETURN CONNECTIONS	
HEATING OUTPUT		HEADS		MINIMUM SYSTEM FLOW RATE			
kW	(Btu/h)	METRES	(FEET)	LITRES/MIN.	(GALL/MIN.)	METRES	(FEET)
17.6	60,000	2.3	7.4	14.30	3.10	3.25	10.7
16.1	55,000	2.6	8.4	13.57	2.99	2.87	9.4
* 14.6	48,000	2.9	9.3	12.31	2.71	2.35	7.7
11.7	40,000	3.5	11.3	9.86	2.17	1.90	5.9
* FACTORY PRESET							

NOTE:- THE INFORMATION CONTAINED IN TABLE 4 IS BASED ON AN 17°C (30.6°F) SYSTEM DESIGN TEMPERATURE DIFFERENCE. THE MINIMUM REQUIRED FLOW RATE THROUGH THE BOILER IS 9.86 L/M (2.17 GPM)

# INSTALLATION INSTRUCTIONS

## Installation Warning

Care should be taken to ensure no foreign matter is left in either the gas or water pipework as they could cause damage to the appliance.

## 1 Gas Supply

The local Gas Region should be consulted, at the installation planning stage, in order to establish the availability of an adequate supply of gas.

An existing service pipe **MUST NOT** be used without prior consultation with the Local Gas Region.

A gas meter can only be connected by the Local Gas Region, or by a Local Gas Region Contractor.

An existing meter should be checked, preferably by the Gas Region, to ensure the meter is adequate to deal with the rate of gas supply required.

The boiler requires 2.76 m<sup>3</sup>/h (97.5 ft<sup>3</sup>/h) of gas. The gas meter and supply pipes shall be capable of supplying this quantity of gas in addition to the demand from other appliances being served by it. Under no circumstances should the gas supply be less than the appliance gas inlet connection (22 mm dia.).

The meter outlet governor should ensure a nominal dynamic pressure of 20 mbar (8 in. wg). The complete installation including the meter must be tested for gas soundness and purged in accordance with the recommendations made in BS.6891.

NOTE:- Both the user and the manufacturer rely upon the installer, whose job is to install the boiler and connect it to a correctly designed heating system. THE INSTALLER SHOULD ACQUAINT HIMSELF WITH THE CONTENTS OF THIS PUBLICATION AND THE RELEVANT BRITISH STANDARDS CONCERNING INSTALLATION REQUIREMENTS.

## 2 Location of Boiler

In siting the combination boiler, the following limitations **MUST** be observed:

1 The position selected for installation should be within the building, unless otherwise protected by a suitable enclosure, and **MUST** allow adequate space for installation, servicing and operation of the combination boiler, and for air circulation around it. Refer to Section 2.8.

The boiler is not suitable for external installation.

2 This position **MUST** also allow for a suitable flue termination to be made. The combination boiler must be installed on a flat vertical wall which is capable of supporting the weight of the combination boiler, and any ancillary equipment.

3 If the combination boiler is to be fitted in a timber framed building it should be fitted in accordance with the British Gas publication *Guide for Gas Installations in Timber Frame Housing*, Reference DM2. If in doubt, advice must be sought from the Local Gas Region of British Gas.

4 The combination boiler may be installed in any room or internal space, although particular attention is drawn to the requirements of the current I.E.E. Wiring Regulations, and in Scotland the electrical provisions of the Building Regulations applicable in Scotland, with respect to the installation of the combination boiler in a room or internal space containing a bath or shower.

5 Where a room-sealed appliance is installed in a room containing a bath or shower, any electrical switch or appliance control, utilising mains electricity must be so situated that it cannot be touched by a person using the bath or shower. Refer page 10.

6 A compartment used to enclose the combination boiler **MUST** be designed and constructed specifically for this purpose. An existing cupboard, or compartment, may be used provided it is modified accordingly.

7 Where installation will be in an unusual location, special procedures may be necessary. BS. 6798: gives detailed guidance on this aspect.

8 The following clearances shall be made available for installation and servicing.

### INSTALLATION

Above 270 mm (10.6 in) **MINIMUM** - SEE NOTE

In front 450 mm (18 in)

Below 270 mm (10.6 in)

Side - SEE NOTE

NOTES:- Site conditions vary and the installer should ensure there is adequate space above and at the sides of the appliance, before commencing the installation.

Some optional flue arrangements may well require additional clearances.

### SERVICING AND OPERATION

Above 270 mm (10.6 in)

In front 450 mm (18 in)

Below 270 mm (10.6 in)

Left hand side 30 mm (1.2 in)

Right hand side 30 mm (1.2 in)

### 3 Flue Position

**IMPORTANT:-** The flue system shall be installed in accordance with the recommendations contained in BS 5440:1. Refer to Table 3 - regarding standard flue assembly and extension flue kit.

1 The boiler MUST be installed so that the terminal is exposed to the external air.

2 It is important that the position of the terminal allows free passage of air across it at all times.

3 If the terminal discharges into a pathway or passageway check that combustion products will not cause nuisance and that the terminal will not obstruct the passageway.

4 In certain weather conditions a terminal may emit a plume of steam. Positions where this would cause a nuisance should be avoided.

#### 5 IMPORTANT REQUIREMENT

The correct dimensional relationship between the terminal and any obstruction, openable window or ventilator shown in Fig. 2 is stipulated in Table 5.

Vertical flue installation and termination must be in accordance with the relevant parts of BS.5440:1: 1990

It is **ESSENTIAL TO ENSURE**, in practice, that products of combustion discharging from the terminal cannot re-enter the building, or any other adjacent building, through ventilators, windows, doors, other sources of natural air infiltration, or forced ventilation/air conditioning systems. If this should occur, the appliance **MUST** be **TURNED OFF IMMEDIATELY** and the Local Gas Region consulted.

6 Where the lowest part of the terminal is fitted less than 2m (6.6 ft) above a balcony, above ground, or above a flat roof to which people have access, the terminal **MUST** be protected by a purpose designed guard.

Terminal guards are available from: Argos Building and Heating Supplies Ltd., and from 'Tower Flue Components' Ltd., Vale Rise, Tonbridge, Kent. TN9 1TB.

The terminal guard reference is K3 (GC N<sup>o</sup> 393554). Argos part n<sup>o</sup> ANOMX39. Refer to Section 6 for details and fixing of the guard.

7 Where the terminal is fitted within 850 mm (34 in) of a plastic or painted gutter, or 450 mm (18 in) of painted eaves, an aluminium shield of at least 1500 mm (59 in) long should be fitted to the underside of the gutter painted surface.

8 The air inlet / products outlet duct and the terminal of the boiler **MUST NOT** be closer than 25 mm (1 in) to combustible material.

### 4 Air Supply

Detailed recommendations for air supply are given in BS.5440:2. The following notes are intended for general guidance:

1 It is **NOT** necessary to have a purpose provided air vent in the room or internal space in which the boiler is installed.

2 If the boiler is to be installed in a cupboard or compartment, permanent air vents are required (for cooling purposes) in the cupboard/compartment, at both high and low levels.

The air vents must either communicate with a room/internal space, or be direct to outside air.

The minimum effective areas of the permanent air vents, required in the cupboard/compartment, are specified in Table 6.

3 Both air vents **MUST** communicate with the same room or internal space, or **MUST** both be on the same wall to outside air.

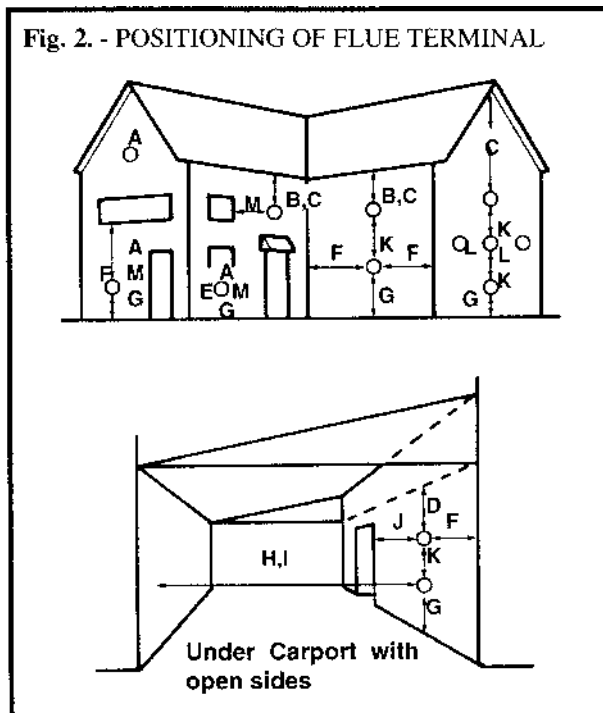


Table 5 TERMINAL POSITIONS

Terminal Position	Minimum Spacing
A	Directly below an openable window, air vent or any other ventilation opening
B	Below guttering, drain pipes or soil pipes
C/D	Below eaves, balconies or carport roof
E	From vertical drain pipes or soil pipes
F	From internal or external corners
G	Above adjacent ground, roof or balcony level
H	From a surface facing the terminal
I	From a terminal facing the terminal
J	From an opening in the carport (eg door, window) into dwelling
K	Vertically from a terminal on the same wall
L	Horizontally from a terminal on the same wall
M	Adjacent to opening

Table 6 FOR BOILER IN CUPBOARD/COMPARTMENT

Position of air vent	Air from room/ internal space		Air direct from outside	
	cm. <sup>2</sup>	(in. <sup>2</sup> )	cm. <sup>2</sup>	(in. <sup>2</sup> )
HIGH LEVEL	267	(41)	134	(21)
LOW LEVEL	267	(41)	134	(21)

# REQUIREMENTS FOR SEALED SYSTEMS

## 1 General

The appliance is suitable for both open vent and sealed central heating systems.

**NOTE:** For open vent option see instructions supplied with open vent kit.

**IMPORTANT:- SEALED SYSTEMS MAY BE FILLED, COMMISSIONED OR DRAINED BY A COMPETENT PERSON ONLY.**

The installation shall comply with the recommendations made in BS 6798 and BS 5449. Refer to Table 2 for information relating to flow and return pipework.

When designing the heating system refer to Table 4 - page 6.

Consider the output requirements of the heating system under consideration - **MAXIMUM 17.6 kW (60,000 Btu/h)** - and note the pump head available. (Table 4)

Note the required minimum system flow rate which is based on an 17 °C temperature difference across the HEATING SYSTEM flow and return.

If the system is to operate efficiently the available pump head should not be exceeded or heat output from the radiators may not reach full output under cold weather conditions.

**A MINIMUM FLOW RATE THROUGH THE BOILER OF 9.86 L / MIN (2.17 gpm) IS REQUIRED IRRESPECTIVE OF HEATING LOAD.** Note that requirement will be satisfied at all heating loads of 11.7 kW (40,000 Btu/h) and above, provided the correct system temperature difference of 17 °C (20°F) is achieved at all times.

A suitable bypass should be fitted and set to achieve the minimum flow rate. Refer to Table 4 and Fig. 3.

The boiler will provide domestic hot water virtually instantaneously at its outlet. However the time taken for hot water to reach any particularly draw off point will depend upon the length of service pipework.

During domestic hot water draw off the central heating service is switched off automatically and is switched on automatically after draw off, providing the controls are calling for heat.

The boiler contains an integral circulating pump. A separate heating pump is not required.

All external heating controls **MUST** be suitable for mains voltage application. Refer to Requirements for Electrical Wiring, Section 3 (Fig. 5).

## 2 Pressure Gauge

The appliance is fitted with a suitable pressure gauge - range 0-4 bar. The gauge is connected via a capillary tube to the heating return pipe on the suction side of the internal pump.

## 3 Safety Valve

The boiler is fitted with a spring loaded safety valve set to operate at 3 bar (45 psi). Refer to Fig. 1 No 6, page 4.

A suitable copper discharge pipe 15 mm minimum diameter **MUST** be fitted so that any discharge is directed away from the appliance. The pipe shall terminate such that any discharge from it causes no hazard either to persons, property or electrical installations within or outside the appliance casing.

**IMPORTANT:-** The safety valve **MUST NOT BE USE** to drain the boiler since dirt in the system may cause the valve to not reseat; all draining should be done through the boiler down valve. The operation of the safety valve **MUST** be checked during the initial commissioning of the appliance and any subsequent commissioning following servicing of the appliance.

Note:- The period between services should **NOT EXCEED TWELVE MONTHS.**

## 4 Pump

**DO NOT MOVE THE PUMP SETTING FROM MAXIMUM.** A reduction in pump setting will reduce domestic hot water output and may reduce central heating output from radiators.

## 5 Expansion Vessel

The expansion vessel fitted to the boiler is of the diaphragm type, precharged to 0.5 bar (7.3 psi) with a capacity of 7 litres (1.54 gal). The system static head, ie the vertical distance measured from the top of the boiler to the highest point of the system plus 550 mm (22 in) **MUST not exceed** the initial charge pressure of 0.5 bar (7.3 psi), equivalent to 5m (17 ft) of static head.

When the system static head exceeds 5 m (17 ft) the expansion vessel pressure should be increased. Refer to Table 7.

The top of the expansion vessel is fitted with a schraider valve to facilitate increasing the precharge pressure.

## 6 System Volume

The system volume that can be accommodated by the appliance integral pressure vessel depends upon the initial charge pressure and the amount by which the system is pressurised.

Table 7 provides information on the maximum system volume the appliance pressure vessel can sustain under differing design conditions.

If the system design provides for conditions outside the capacity of the appliance pressure vessel, an additional vessel can be fitted. The connection of the additional vessel should be made to the heating system primary return pipe as close to the appliance as possible.

Ensure the total capacity of both vessels is adequate for the system and take note of the recommendations made in BS 5449 and BS 6798:1987

**Table 7 BASED ON 3.0 BAR SAFETY VALVE SETTING**

Vessel charge and initial system pressure	bar	0.5	1.0	1.5
	psi	7.3	14.5	21.8
Total water content of system using 7l (1.54 gal) capacity expansion vessel	l	87	64	44
supplied with appliance	gal	18.5	14.0	9.7
For systems having a larger capacity MULTIPLY the TOTAL system capacity in litres (gallons) by the factor		.0833	.109	.156
to obtain the TOTAL MINIMUM expansion vessel capacity required litres (gallons)				

**NOTE:-** When the boiler is operating at maximum operating temperature, providing heating with all radiators operating, the pressure gauge should not indicate more than 2.5 bar (36 psi). If the reading exceeds this figure an additional expansion vessel is required.

## 7 Filling and Venting the System

Before connecting the appliance to the primary domestic hot water system ensure the boiler and system pipework are thoroughly flushed out.

An automatic air vent is fitted to the top of the appliance domestic hot water heat exchanger. Refer Fig. 1.

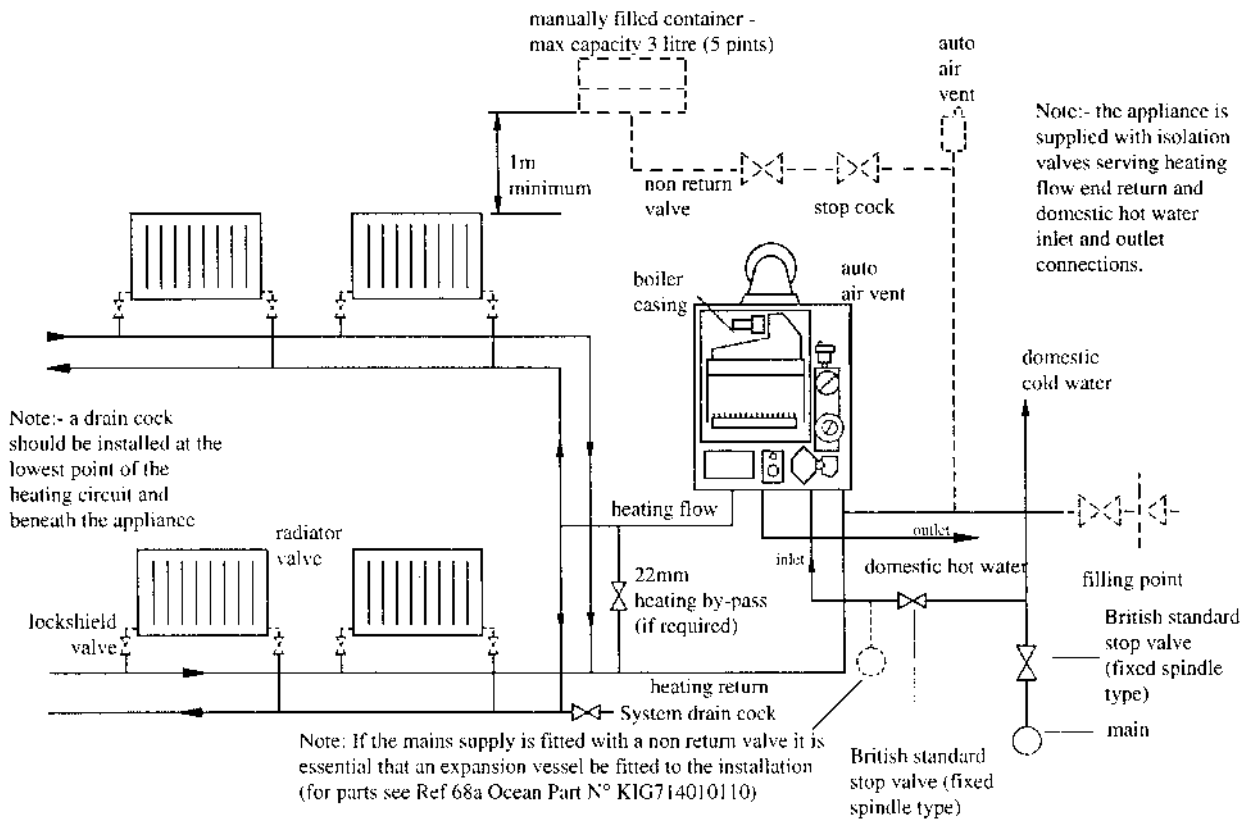
Prior to filling the cap should be opened so that air can discharge freely.

There are two methods of filling the system shown in this literature. Both methods comply with the recommendations made in BS 6798:1987. Refer to Fig. 3.

**NOTE:-** The local Water Undertaking **MUST** approve ALL methods of filling sealed systems.

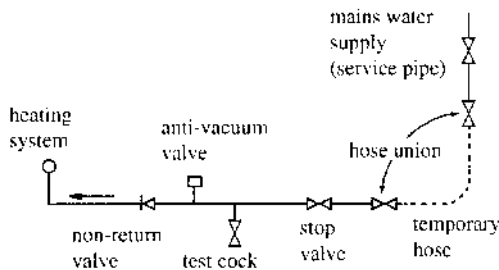
**Fig. 3 SEALED PRIMARY DHW AND HEATING SYSTEM DESIGN CONSIDERATIONS.**

Note:- The appliance is designed for a maximum mains water supply pressure of 8 bar. Don't use a higher pressure. If necessary fit a water pressure reducing valve to ensure design pressure is not exceeded.

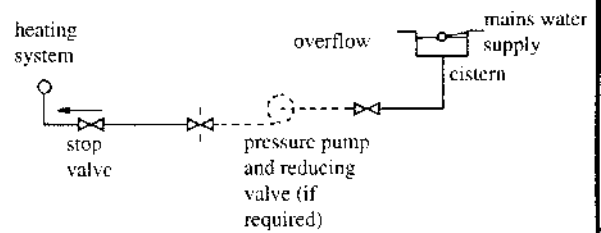


**ALTERNATIVE METHODS OF FILLING SYSTEM**

**METHOD 1. (complies with BS 6798.1987)**



**METHOD 2. (complies with BS 6798.1987)**



**NOTES**

- When it is not possible to avoid a situation where the initial system pressure and static head are equal a manually fitted top up container should be fitted as shown above. Take note of the requirements relative to container capacity; height above system, inclusion of a non-return valve, stop cock and automatic air vent in the feed pipe. Note also the feed pipe connection is made to the heating return as close to the appliance as possible.
- The local Water Undertaking MUST approve ALL connections between the system and a water storage cistern or water main supplying domestic hot water.

**8 System Checks**

Ensure the system is thoroughly flushed out with cold water prior to filling up to 1.5 bar (21.8 psi). Clear all air and check for water soundness. Reduce the pressure until the initial design pressure for the system is obtained. Check the operation of the safety valve at this time.

Ensure it discharges in a safe area. Refer Section 3- page 8. The initial system pressure should not exceed 1.5 bar (21.8 psi) (green area). After the boiler has been commissioned and the system brought up to maximum design temperature check for water soundness. While the system remains hot turn off the appliance and drain off all water, through the system drain cock. Refill the system and vent it. Reset the initial system pressure to between 1.5 bar (green area).

# DOMESTIC HOT WATER SUPPLY TO THE BOILER AND OTHER APPLIANCES

## 1 General

The following information is for guidance only. Contact the local Water Undertaking for specific information and requirements before fitting the appliances referred to below.

The appliance is intended for connection to a mains water supply at a maximum pressure of 8 bar (116 psi). DO NOT use at a higher mains pressure. If necessary fit a water pressure reducing valve. When connecting the mains cold water pipe to the appliance ensure the final 600 mm (2 ft) length is copper.

A hot water flow restrictor is fitted to the appliance which limits the hot water to 10 litres per minute.

Higher flow rates will not be harmful to the appliance but may reduce water temperature to an unacceptable level.

Note:- The following appliances have basic requirements for installation:

## 2 Bidets

No anti-syphonage arrangements are necessary provided the outlets are shrouded and it is not possible to attach a temporary hand held spray. A supply of direct mains fed hot and cold water is permitted provided the appliance is of the over-rim flushing type.

## 3 Showers

Fixed head showers require no anti-syphonage arrangements. Loose head showers require an anti-syphonage device to be fitted if it is possible for the heads of the shower to become immersed in bath water.

Alternatively the length of flexible hose shall be fixed so that it is impossible for the shower head to fall closer than 13 mm (0.5 in) to the top edge of the bath. Such an arrangement would avoid the need for an anti-syphonage device.

## 4 Domestic Hot and Cold Water Supply Taps and Mixing Valves

All such devices shall be suitable for use at mains supply pressure.

## 5 Domestic Expansion Vessel

If the domestic system has a check valve installed in the mains water supply to the appliance, then a domestic expansion vessel must be connected to the boiler (ref. Fig. 3 Page 9).

Domestic expansion vessel and connecting pipe reference number KIG714010110 is obtainable from your local merchant stockist or Argos Building and Heating Supplies Ltd. - United House - Goldsel Road - Swanley - Kent - BR8-8EX. Telephone Swanley (0322) 665522

# REQUIREMENTS FOR ELECTRICAL WIRING

## 1 General Safety

Before any electrical work is undertaken ISOLATE THE APPLIANCE FROM THE MAINS SUPPLY.

If an electrical fault should develop after the appliance has been installed, any electrical fault finding undertaken such as earth continuity, polarity and resistance to earth, MUST be carried out by a competent person.

All external wiring MUST comply with current IEE wiring regulations and any local requirements and Health and Safety document n° 635 "The electricity as work regulations" 1989.

## 2 Mains Supply Wiring to the Appliance

The appliance should be connected to the mains supply using no less than 0.75 mm<sup>2</sup> (24x0.02 mm) BS 6500 (Table 16) pvc, 3 core insulated cable.

The supply (fused at 3 A) MUST be capable of being isolated from the appliance using one of the following methods:

- a) A three pin plug and unswitched, shuttered socket outlet complying with BS 1363.
- b) A double pole isolation switch. The switch contacts MUST have a minimum separation of 3 mm on both poles and MUST supply the

boiler and system controls only.

NOTE:- In either case the means of isolation MUST be readily accessible.

c) First remove the white outer case by unscrewing the pozidrive head screws located on the top, lifting and pulling forward.

The cables used to connect the mains electrical supply and extension control systems should first be passed through hole in the guard plate beneath the boiler and then through the cable clamp and plate.

Allow for the length of cable as shown in fig. 4.

THE APPLIANCE MUST BE EARTHED BY CONNECTING THE INCOMING EARTH TO THE BRASS POST adjacent to the connector block. The earth on the connector block may be used for external controls.

After installation carry out electrical safety checks i.e. earth continuity, polarity, short circuit, resistance to earth.

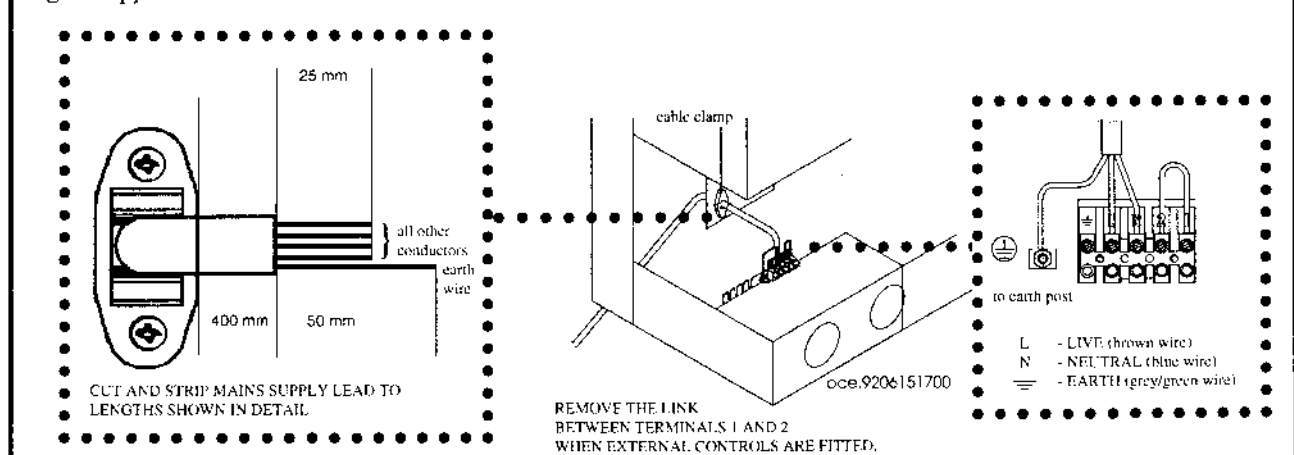
d) Where a room sealed appliance is installed in a room containing a bath or shower the following requirements MUST be complied with.

i) The point of connection of the mains supply to the appliance MUST be situated outside the room.

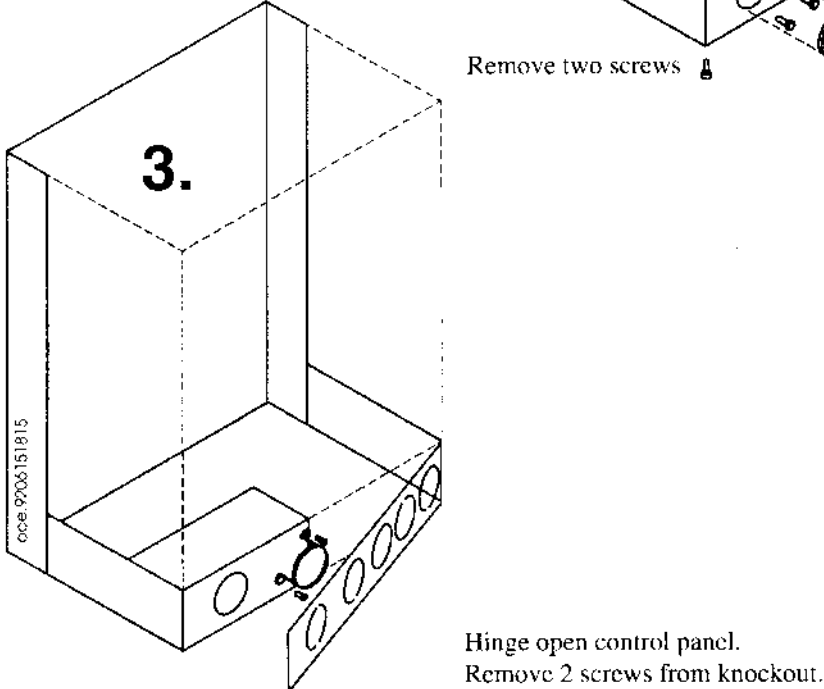
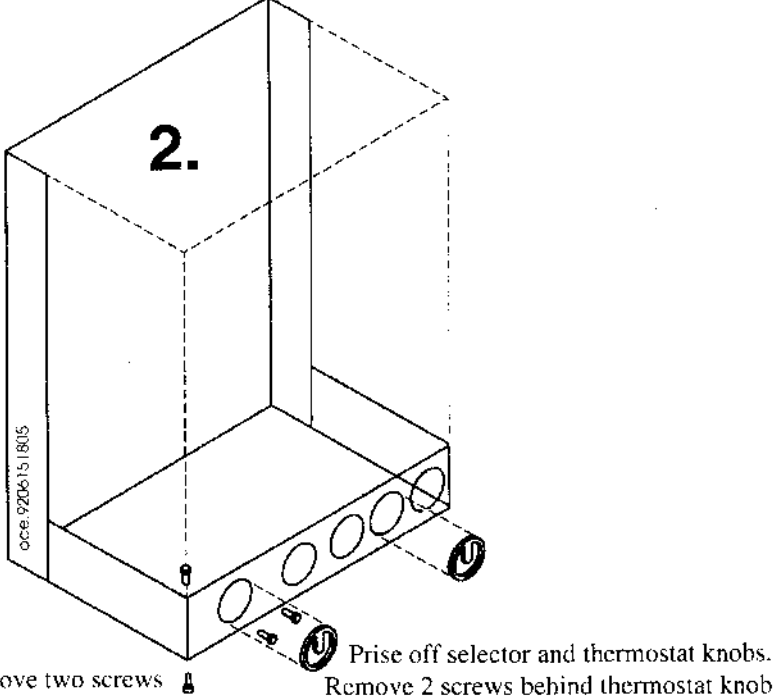
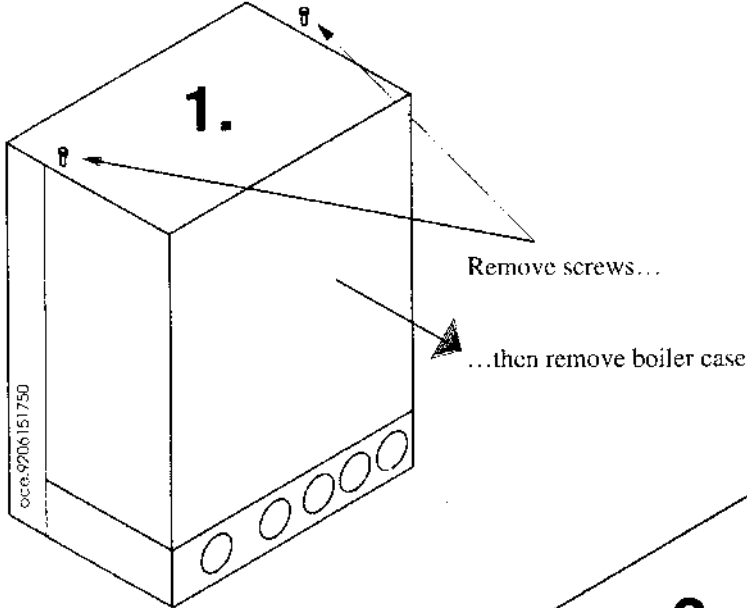
ii) Any person using the bath or shower MUST NOT be able to touch ANY electrical switch or appliance control.

If clock fitted (optional) see page 11).

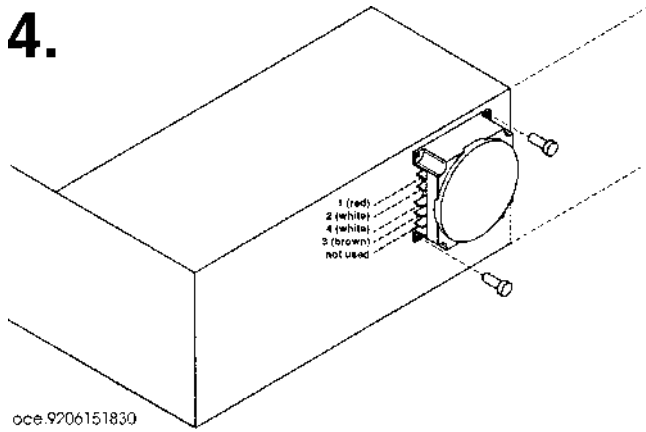
Fig. 4. Appliance terminal block with cover removed.



# HEATING CLOCK OPTION INSTALLATION INSTRUCTION



4.



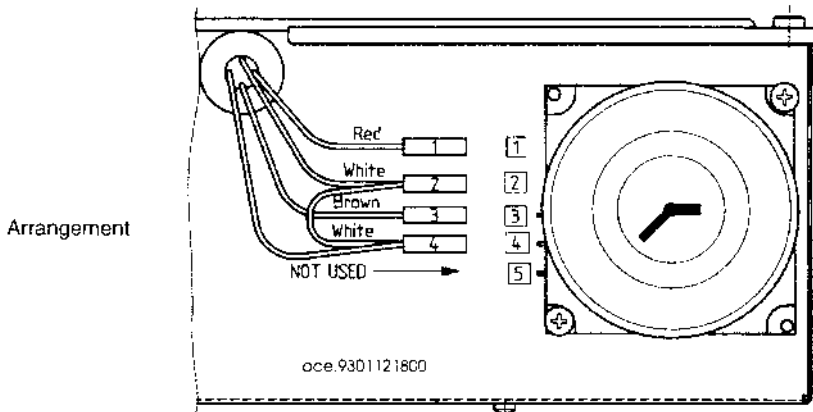
Take the wiring terminals from behind the knockout and connect onto clock as shown.  
Fix clock in place of knockout reusing screws discard knockout.

oce.9206151830

5.

Reassemble control panel to original position.  
Refix all knobs and screws.  
Refix boiler case and secure with screws.

## CLOCK OPTION



Arrangement

oce.9301121800

### HEATING CLOCK INSTRUCTIONS (IF FITTED)

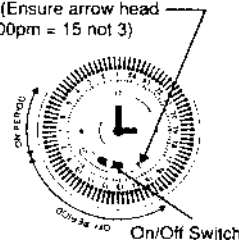
#### 1. SET TIME

Turn outer dial to set clock hands to correct time. (Ensure arrow head corresponds with correct time on 24hr dial e.g. 3.00pm = 15 not 3)

#### 2. SET ON/OFF PERIODS

Select ON time by pushing tappet OUTWARD  
Select OFF time by pushing tappet INWARD

Sketch shows	{	ON	3.00pm to 10.00pm (15-22)
		OFF	10.00pm to 5.00am (22-5)
		ON	5.00am to 8.00am (5-8)
		OFF	8.00am to 3.00pm (8-15)



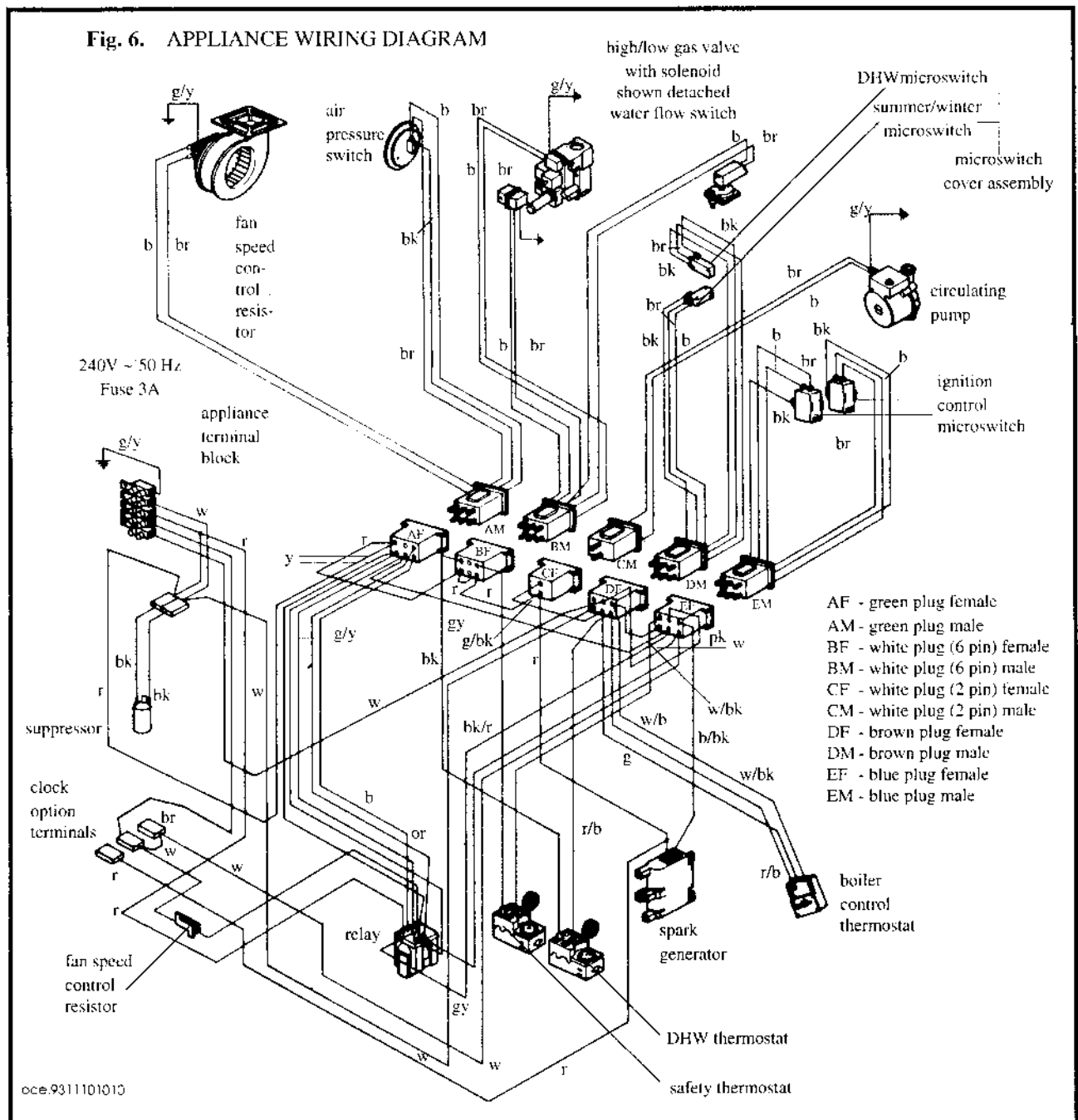
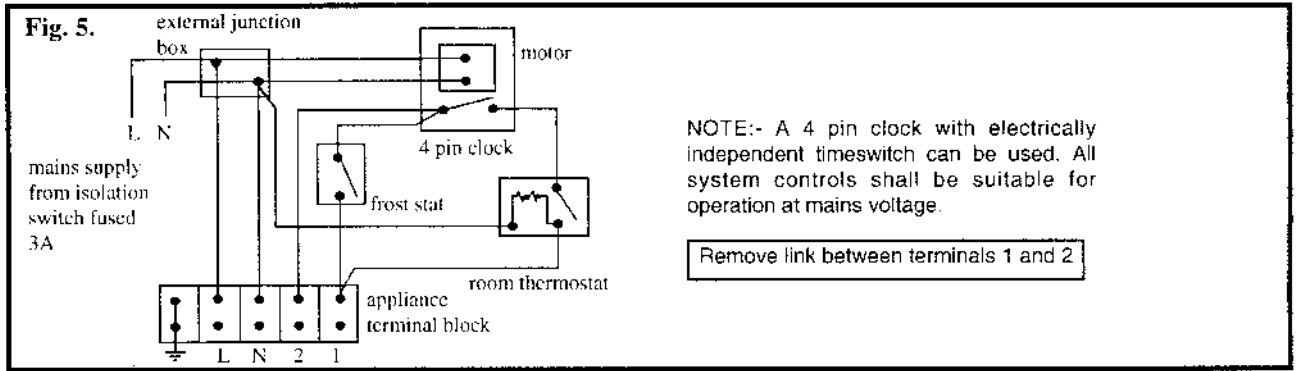
#### 3. MANUAL SWITCH

The clock has a manual ON/OFF switch which operates as follows:

Mid position	Heating ON/OFF as set by tappets
Position 1 (Right)	Heating ON continuously
Position 0 (Left)	Heating OFF continuously

oce.9208141850

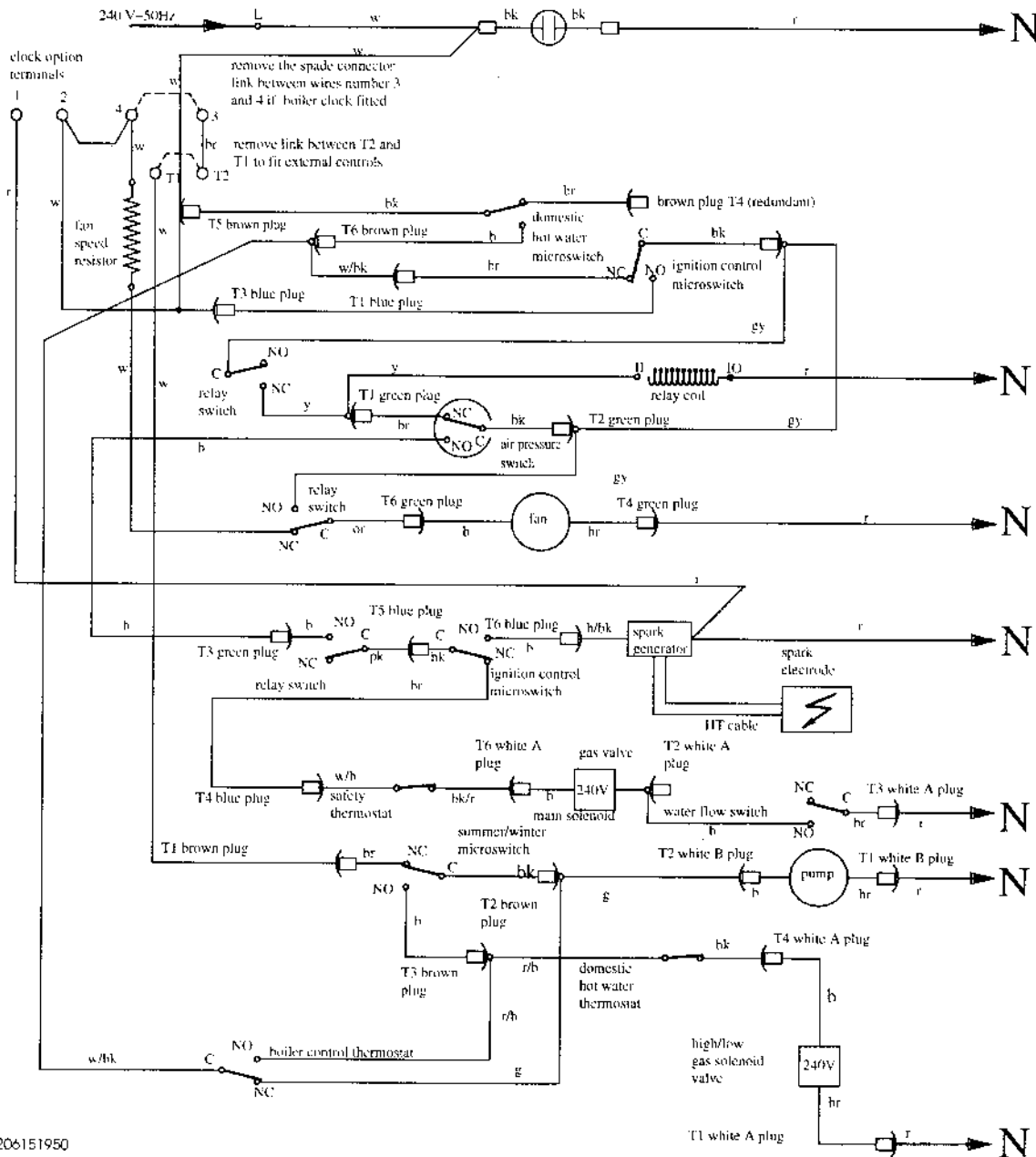
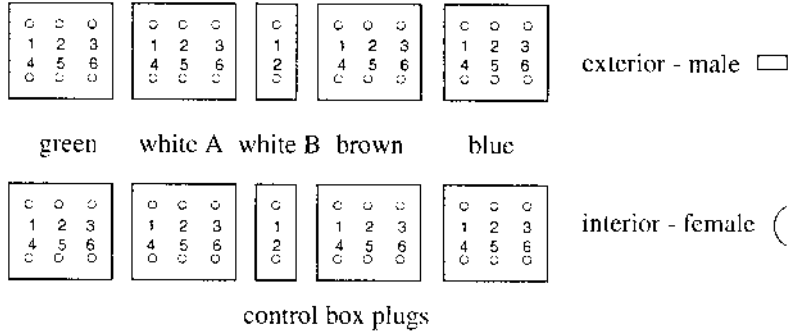
### 3 Wiring of External Clock - Room Thermostat - Frost Thermostat



**Fig. 7. APPLIANCE FUNCTIONAL FLOW DIAGRAM**

Wiring colour codes

- b blue
- bk black
- br brown
- g green
- gy grey
- or orange
- pk pink
- r red
- v violet
- w white
- y yellow
- b/bk blue/black
- b/r blue/red
- w/b blue/white
- bk/g black/green
- bk/r black/red
- w/bk black/white
- g/y green/yellow



oce.9206151950

# INSTALLATION OF THE APPLIANCE

## 1 Fixing Templates - Hardware Supplied

Remove the appliance WALL FIXING TEMPLATES FOR REAR and RIGHT/LEFT HAND FLUE OUTLET from the carton containing the appliance. Unpack the hardware carton and check its contents against the list below.

ONE Wall mounting plate assembly complete with:

Paper templates;

3/4" heating flow isolation valve and safety valve assembly;

3/4" heating return isolation valve;

1/2" domestic mains inlet isolation valve;

ONE plastic bag containing gas cock with flanges straight pipe section / half union; gas supply union elbow and pipe support clip.

ONE small plastic bag containing 'o' ring seal and two M5 hexagon head fixing screws (Fig. 12).

3 off 3/4"x22mm union elbows; } contained  
2 off 1/2"x15mm elbows. } in plastic bag

TWO small plastic bags containing sealing washers for domestic hot water and heating flow/return connections between wall template and boiler internal pipework;

ONE plastic bag containing:

Wall template-upper cross bar extension (left hand side) with single M4 pozidrive fixing screw;

7 N° 10x45mm long wood screws, plugs and washers.

NOTE:- FOUR SETS ONLY NEED BE USED; ONE SET IS SPARE TO REQUIREMENTS.

ONE plastic bag containing flue/air duct support plate with two M4 pozidrive fixing screws and washers and sealing mastic. A sealing mastic for outer wall.

Unpack the carton containing the standard flue kit. Check the content against the list below.

ONE 750 (29.5 in) long x 100 mm dia. plastic air duct / terminal

ONE 750 (29.5 in) long x 60 mm dia. aluminium flue duct

ONE Air Duct Locking Ring (PVC)

ONE Air Duct 'O' Ring Seal

ONE Stainless steel sealing ring

ONE M5 pozidrive screw.

## 2 Fixing the Wall Mounting Plate

The wall mounting plate is supplied with all necessary fittings and accessories to make water and gas connections to the appliance. The plate MUST be mounted on the wall in the position desired for the appliance. The mounting points for the appliance and the fixing holes for the upper and lower cross bars are incorporated in the plate.

Refer to Fig. 8, in particular Note 1, and assemble the wall mounting plate upper cross bar. Refer to Fig. 9 and check that all fittings tails and accessories are correctly mounted.

Using the WALL MOUNTING PLATE mark on the wall to which the appliance is to be fixed the four fixing hole positions AND IF A REAR OUTLET is to be used the position of the concentric AIR/FLUE DUCT outlet. IF EITHER A RIGHT OR LEFT HAND OUTLET is to be used then position also the WALL TEMPLATE FOR RIGHT/LEFT OUTLET. BE SURE to use the correct side of the template which is marked clearly.

Make a hole in the wall through which the concentric AIR / FLUE (aluminium) duct will pass. The hole MUST have a MINIMUM dia. of 110 mm (4.3 in). Refer to note 4, Fig. 9.

Check the horizontal and vertical levels before proceeding.

Drill the four fixing holes in the wall face using an 8 mm (0.3 in dia.) masonry drill. Fix the upper and lower cross bars to the wall face using the plastic plugs and N° 10 screws provided. Recheck the horizontal and vertical levels.

Note:- The acrylic sheet between the upper and lower cross bar should be taut.

Proceed to cut the air and flue ducts to size. Ref. to Section 3 Preparation of the Air / Flue duct, also Figs. 10 and 11.

## 3 Preparation of the Air/Flue Duct

a) Standard flue kit for overall length (L) up to 750 mm

Table 8 FLUE LENGTHS

	LENGTH OF PLASTIC DUCT (L) (NOT INCLUDING TERMINAL)
REAR	$W + 158$ (6.2) mm (in)
LHS	$W + C + 168$ (6.6) mm (in)
RHS	$W + C + 268$ (10.6) mm (in)

The standard flue will accommodate a wall thickness (W) of 592 mm (23.3 in) for rear walls and a wall thickness plus side clearance (W+C) of 582 mm (22.9 in) LHS - and 482 mm (19.0) RHS

The outer air duct is supplied complete with discharge terminal to be fitted. The inner aluminium flue duct is supplied with a flange and small hole at one end for fixing to the appliance turret. Refer to Fig. 10 AIR/FLUE DUCT CONNECTIONS.

Calculate the overall length (L) from table 8.

W = Wall thickness; C = Clearance to respective side wall.

IMPORTANT:- Having determined the length of the air/flue duct needs to be reduced DO cut the same amount from each duct; DO NOT cut any material from the end of the AIR duct to which the TERMINAL is attached or the end of the FLUE duct to be attached to the TURRET ie. the end to which the steel RESTRICTOR ring (flange) is fitted. Refer to Section 4a.

b) Extension flue kits FOR FLUE LENGTHS from 751 mm (23.6 in) to 4500 mm (177.1 inches) MAXIMUM.

Where required total length (L) is greater than 750 mm (29.6 inches) up to 5 (five) extension kits will be needed

DO NOT EXCEED 4500 mm

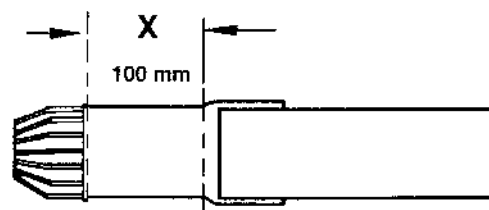
It is advisable to keep flue lengths as short as possible as long flues increase the risk of condensation.

Calculate L and observe all instructions as in (a) detailed above. Fully engage the plastic air ducts, measure off L as in (a) above and cut any excess off the PLAIN end of the EXTENSION duct, BUT REFER TO NOTE BELOW.

**VERY IMPORTANT NOTE:-** The air duct is inserted into the turret by 20 mm (0.79 in) and an extra 5 mm (0.2 in) is gained unavoidably at each extension joint.

Therefore if L is greater than 750 mm (29.5 inches) (standard flue) then the outer air flue duct must be cut 5 mm shorter than the internal aluminium duct.

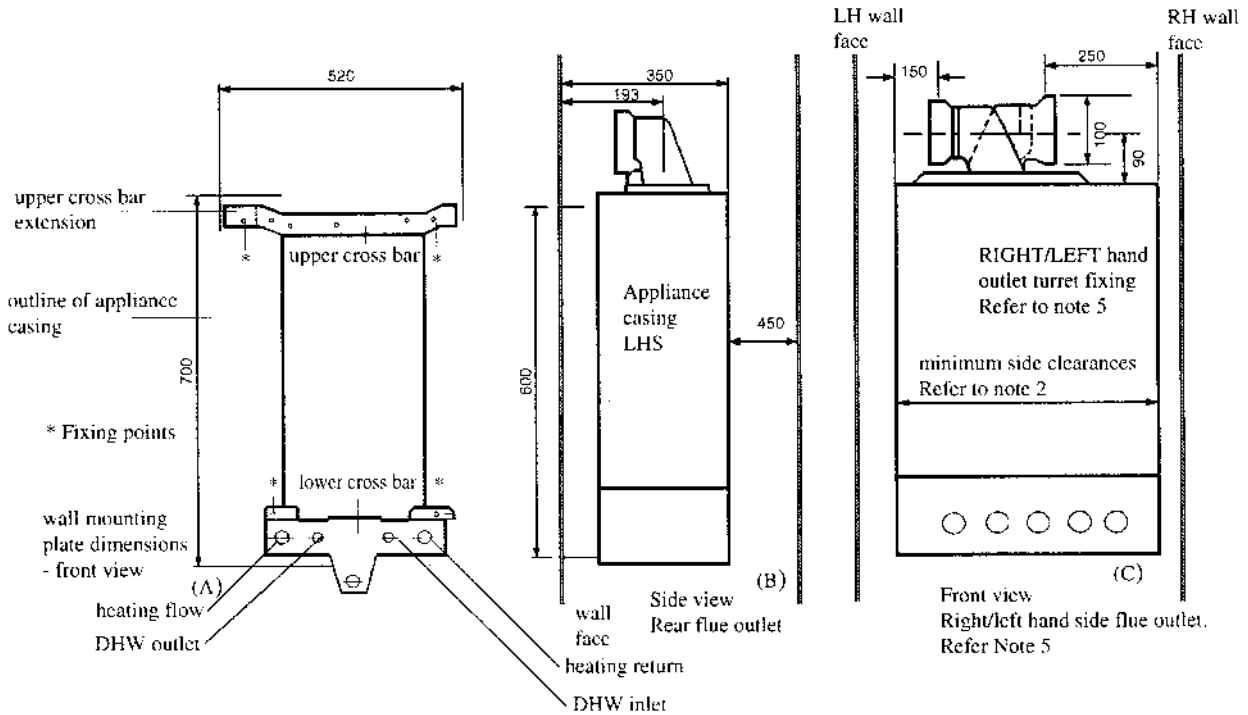
This applies to each extension duct used and if this is not accounted for the aluminium duct will not enter the correct distance into the terminal.



If more than one extension kit is used the total amount (5 mm x number of kits) can be cut from the final duct.

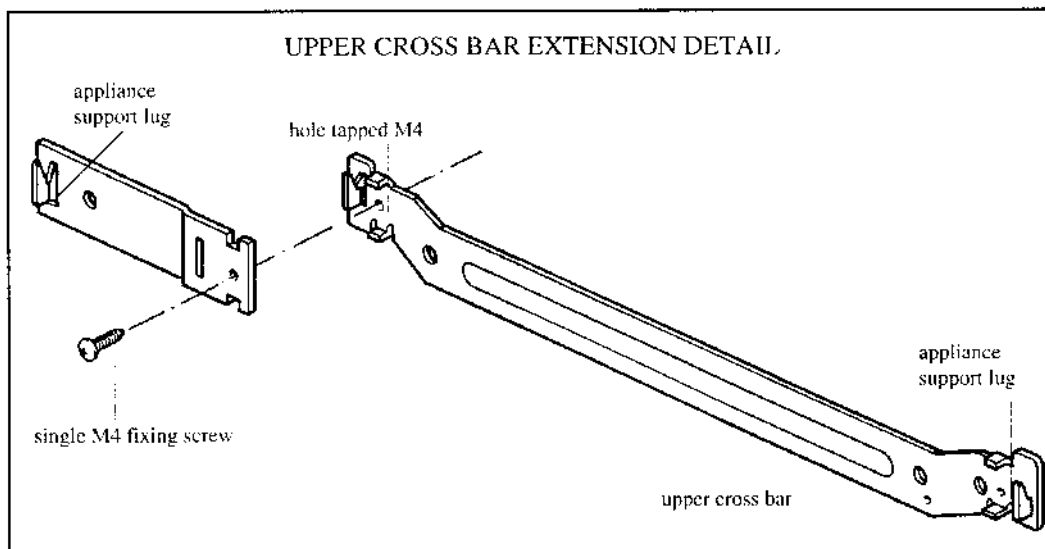
The length of the final duct to the terminal must not be less than 100 mm (3.9 inches).

**Fig. 8. DIMENSIONAL RELATIONSHIP BETWEEN APPLIANCE AND WALL FACE WALL MOUNTING REQUIREMENTS**

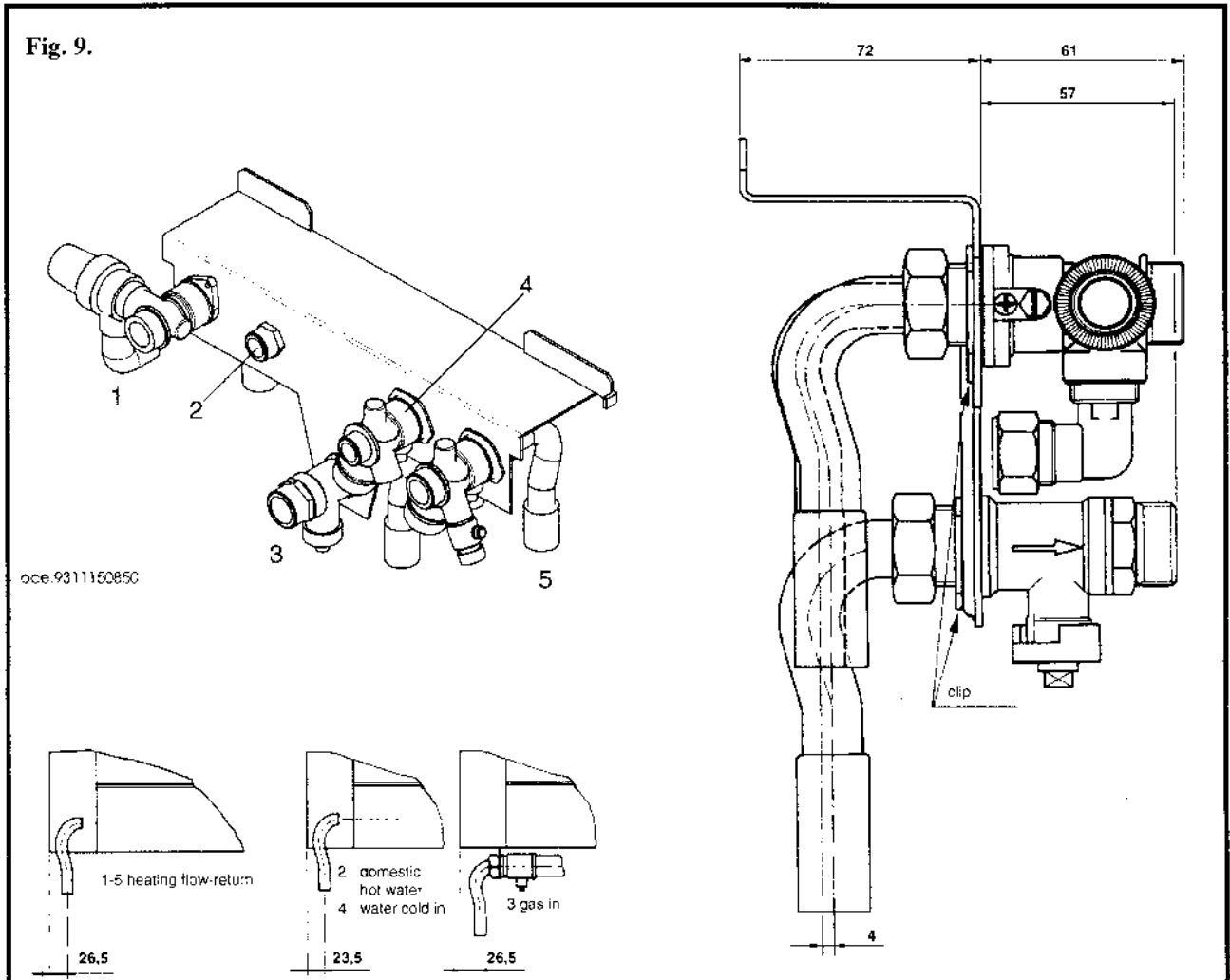


REFER TO APPLIANCE WALL FIXING TEMPLATE. IF RIGHT/LEFT HAND OUTLET IS TO BE USED REFER ALSO TO APPROPRIATE WALL TEMPLATE.

- Notes:-
1. The upper cross bar extension is intended to fit the LEFT HAND END of the upper cross bar. The extension fits IN FRONT OF the main bar
  2. The MINIMUM left and right hand side clearances should apply IRRESPECTIVE of chosen flue outlet position i.e. REAR - RIGHT/LEFT HAND.  
Refer to Section 2.8. LOCATION OF BOILER for complete information on required all round clearances.
  3. When marking off the wall face to locate the centre of either a LEFT HAND OR RIGHT HAND flue outlet note that the concentric flue duct centre is 193 mm (7.6 in) forward of the REAR WALL FACE and 139 mm (5.5 in) above the top of the upper cross bar.
  4. Under no circumstances must the flue system slope downwards from the terminal to the appliance.
  5. The appliance is supplied with its flue turret in the rear outlet position. The turret may be repositioned by removing the four M5 hexagon head screws fixing it to the top of the appliance. Refer first to Fig. 10. Remove the outer casing as described under Section 5. Replacement of the four M5 hexagon head screws will be made easier by removing the inner casing front panel. Refer to Section 4 - Servicing of Components - paragraph 1.



**Fig. 9.**



Each kit is packed in a single carton containing:  
 ONE plastic air duct with spigot at one end and socket at the other;  
 ONE aluminium flue duct. Quantity of SEALING TAPE;  
 ONE clamping band complete with two M4 hexagon head fixing screws / nuts and FOUR washers.  
 The **IMPORTANT NOTE** does not apply to the aluminium flue duct which may now be matched to the assembled plastic air duct and cut to the same length L.  
 The aluminium flue duct is butted at the joint (not sleeved) and wrapped with sealing tape.

**c) Assembling the ductwork**

**HORIZONTAL**

The standard flue kit supplied with the boiler should always be used to start the flue assembly at the flue turret.  
 Extension kits if used should be fitted with the socket end towards the boiler flue turret.

**VERTICAL**

When using the vertical flue turret off the boiler any extension kits used must be assembled with the sockets pointing away from the boiler turret.

**IMPORTANT:-** Having cut accurately the **OVERALL LENGTH OF AIR/FLUE DUCT REQUIRED**:

DO ensure the final assembly complies with Fig. 11 - page 19.  
 DO ensure the end of the **STANDARD ALUMINIUM FLUE DUCT**, with fixing hole and the **RESTRICTOR RING**, is fitted to the turret correctly using the M5 fixing screw provided.

DO NOT reduce the length of either the **STANDARD (PVC) air duct** or **STANDARD aluminium flue duct**. The **STANDARD air duct** can be identified as having no socket end.

DO NOT reduce the length of the **EXTENSION air duct** by cutting from the socket end. **ALWAYS** cut from the spigot (plain) end.

Using the clamping bands assemble the aluminium flue duct extension - butt the joints together and wrap with sealing tape before fitting the clamps.  
 DO ensure the ends of the aluminium flue ducts are closely butted together in the **CENTRE** of the clamping bands.  
 DO ensure the clamping bands are tightened up securely using the M5 screws, washers and nuts provided.  
**THE INNER FLUE SHOULD BE COMPLETELY RIGID AFTER ASSEMBLY.**

**4 Installing the Air/Flue Duct**

**a) Standard kit REAR RIGHT/LEFT HAND OUTLET**

Fix the terminal to the air duct inlet with the two M3 pozidrive screws. Refer to Fig. 10.

Slide the aluminium flue duct down inside the open end of the air duct - enter the end without the flange - until it just projects into the terminal.

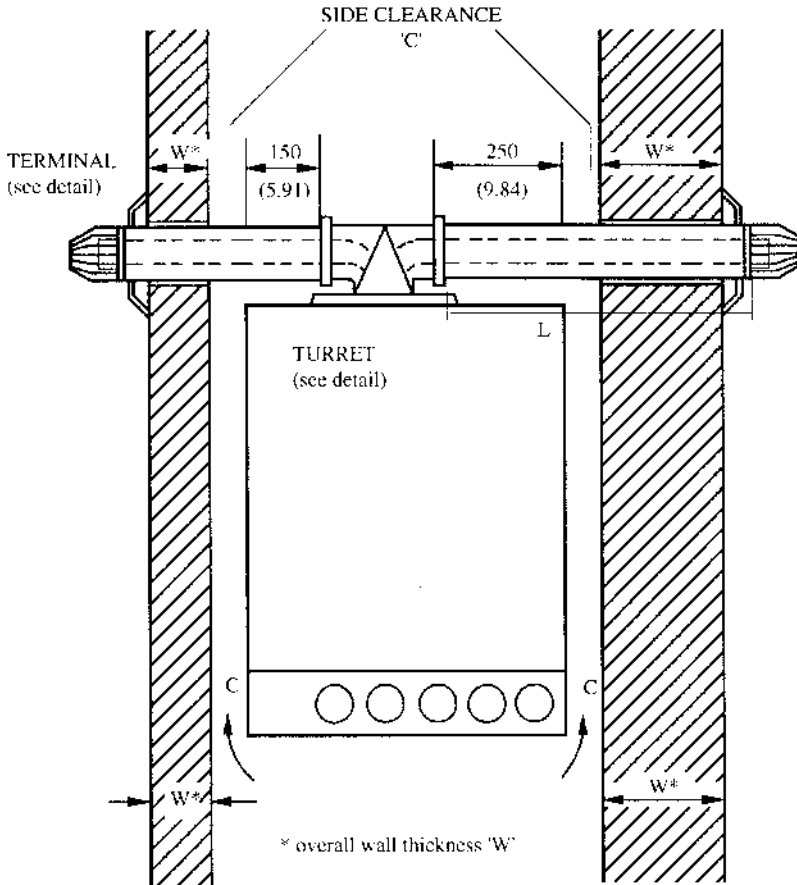
Working either inside or outside the building push the duct assembly through the hole in the wall so that the open end of the air duct is flush with the inner wall face.

Draw the open end of the air duct forward and pass the air duct locking ring and O-ring seal over it.

**ENSURE** the internally threaded portion of the **LOCKING RING** is facing toward the appliance turret when the boiler is mounted on the wall.

**Fig. 10. AIR/FLUE DUCT CONNECTIONS - STANDARD FLUE KIT SHOWN**

LH OUTLET

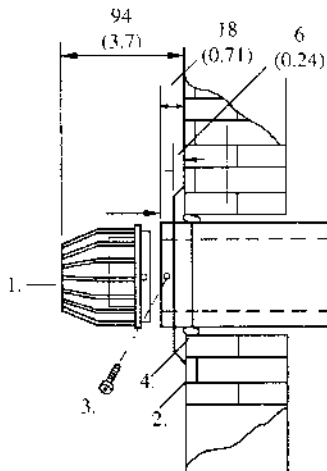


RH OUTLET

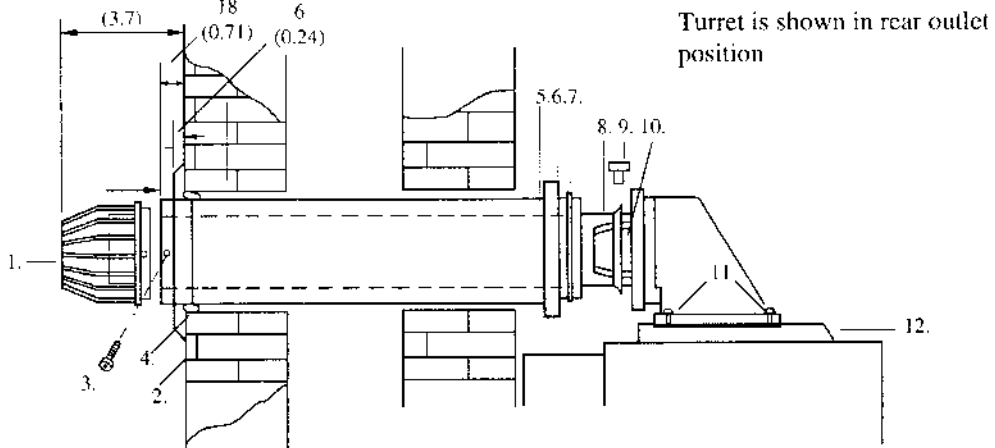
TERMINAL  
(see detail)

1. Discharge terminal
2. Stainless steel sealing collar
3. Two M3 pozidrive fixing screws fix terminal to air duct (left and right hand side)
4. Sealing mastic
5. Air duct - 100 mm (3.9 in) dia
6. Air duct locking ring
7. Air duct 'O' ring seal
8. Aluminium flue duct - 60 mm (2.4 in) dia
9. Single M5 pozidrive screw fix flue duct to turret outlet
10. Steel restrictor flange fixed to end of flue duct.
11. Four M5 hexagon head screws fix turret to top of appliance
12. Sealing gaskets

**FLUE TERMINAL ASSEMBLY DETAIL**



**FLUE CONNECTION DETAIL**

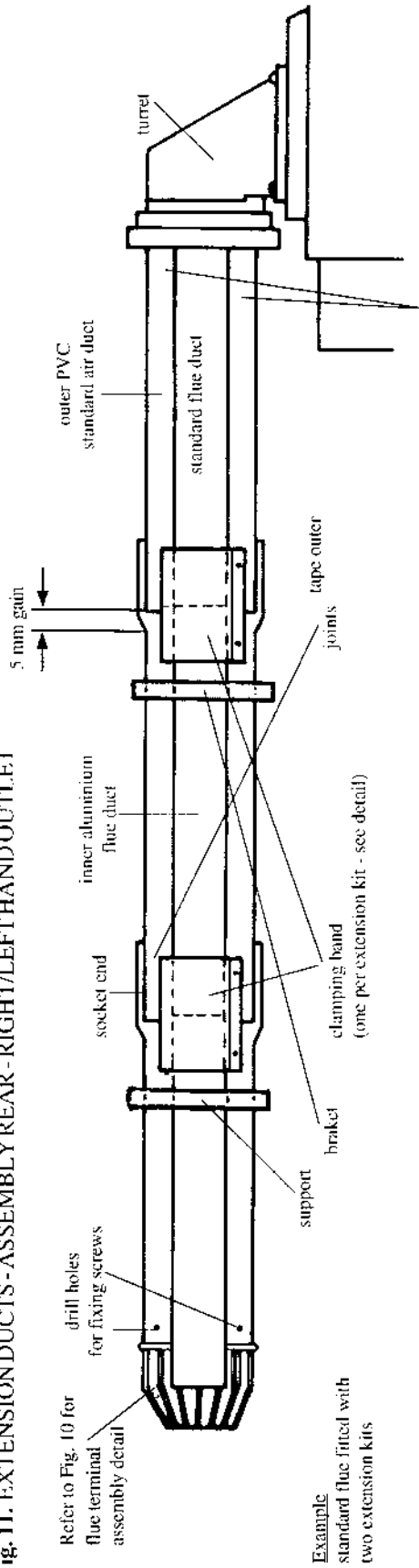


Turret is shown in rear outlet position

eg. If  $W = 370 \text{ mm (14.6 in)}$  and distance from both sidewalls is  $100 \text{ mm (3.9 in)}$  then cut:-  
 LENGTH (L) =  $370 (14.6) + 158 (6.2) = 528 \text{ mm (20.9 in)}$  REAR OUTLET  
 =  $370 (14.6) + 168 (6.6) + 100 (3.9) = 638 \text{ mm (25.1 in)}$  LHS OUTLET  
 =  $370 (14.6) + 268 (10.6) + 100 (3.9) = 738 \text{ mm (29.1 in)}$  RHS OUTLET

When supplied the appliance turret is positioned with its air/flue duct socket facing the REAR. For RIGHT/LEFT hand outlet remove the FOUR M5 hexagon head screws retaining the turret in position. TAKE CARE NOT TO DAMAGE THE SEALING GASKETS. Rotate the turret to be left or right depending on the desired flue outlet position and refit. ENSURE THE SEALING GASKETS ARE POSITIONED CORRECTLY AND PROVIDE AN AIR TIGHT SEAL.

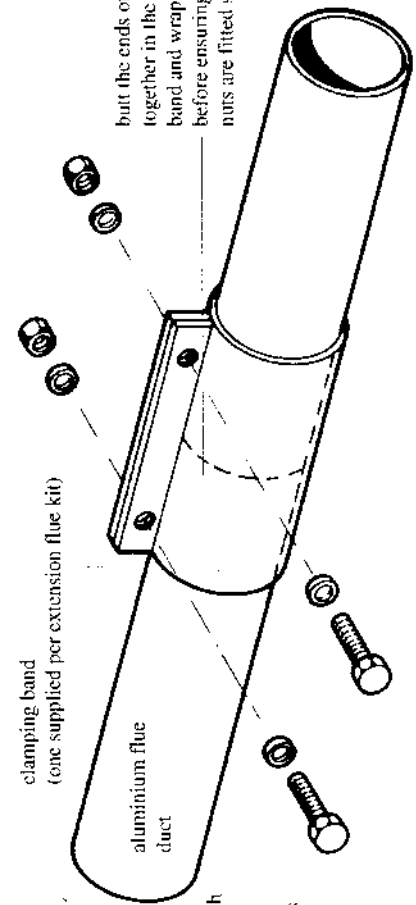
**Fig. 11. EXTENSION DUCTS - ASSEMBLY REAR - RIGHT/LEFT HAND OUTLET**



Note: Ensure the standard flue duct with resinator ring is fitted correctly to the turret. Refer to Fig. 10 for flue connection detail. DO NOT cut material from the socket ends of the air ducts



**ALUMINIUM FLUE DUCT CLAMPING BAND DETAIL**



Note: - The following is supplied with each clamping band:

- 2 n° M5 hexagon head fixing screws
- 2 n° M5 hexagon nuts
- 4 n° M5 washers

### b) Extended air/flue duct

#### REAR RIGHT/LEFT HAND OUTLET.

Check the terminal is securely fixed to the air duct inlet with the two M3 pozidrive screws provided. Refer to Fig. 10.

#### IMPORTANT

Final assembly of ducts.

Before final fixing of the extension flue ducts ensure by laying out the completed assembled flue ducts on the floor to ensure both ducts are the same length.

Depending on the particular circumstances prevailing on site and the overall length of ductwork either fully assemble both inner flue duct and outer air ducts, before passing the complete assembly through the hole(s) cut to accept it, or pass the ducts through the hole(s) in stages - connecting one section to the next in line progressively, from inside or outside as necessary/convenient.

Draw the air duct forward of the inner wall face.

**REAR OUTLET ONLY:- PASS THE END OF THE AIR DUCT THROUGH THE WALL, FAR ENOUGH TO PASS THE AIR DUCT LOCKING RING AND 'O' RING SEAL OVER IT.**

**RIGHT/LEFT HAND OUTLET ONLY: PASS THE AIR DUCT LOCKING RING AND 'O' RING SEAL OVER IT.**

**ENSURE** the internally threaded portion of the LOCKING RING is facing toward the appliance turret when the boiler is mounted on the wall.

### c) Bends, 90°, 45° and offsets.

#### (1) Bend 90°

A 90° bend is equal to 0.75 m (29.6 inches) of straight flue, therefore maximum straight length allowed with a 90° bend is 3.75 m (147.6 inches).

Installation details are enclosed with each bend and these must be followed in order to prevent combustion problems.

#### (2) Bend 45°

A 45° bend is equal to 0.45 m (17.7 inches) of straight flue. So the maximum straight flue length allowed using 2 x 45° bends is 3.6 m (141.7 inches)

Installation details are enclosed with each bend and these must be followed in order to prevent combustion problems.

#### (3) Offsets

An offsets bend is equal to 0.85 m (33.4 inches) of straight flue so the maximum straight flue allowed using one offset fitting is 3.65 m (143.7 inches).

Installation details are enclosed with each offset and these must be followed in order to prevent combustion problems.

#### (4) Vertical Flue Terminal

**IMPORTANT** 90° bends must not be used with the vertical flue terminal.

Maximum straight vertical flue length is 3.5 m (137.8 inches) two 45° bends are equal to 0.9 m (35.4 inches) so maximum straight flue allowed using 2 x 45° bends is 2.3 m (90.5 inches).

An offsets bend is equal to 0.85 (33.4 inches) of straight flue. So the maximum straight flue length allowed using one offset fitting is 2.35 m (92.5 inches).

The vertical flue terminal must only be used with the vertical flue turret fitted in the boiler.

Installation instructions both vertical terminal and vertical turret are enclosed with each item and must be followed in order to prevent combustion problems. For vertical flue terminals refer to BS 5440:1: 1990 where applicable together with the dimensions shown on the instructions enclosed with vertical terminal.

**IMPORTANT** Final assembly of ducts. Before final fixing of extension flue ducts ensure by laying out the assembled flue ducts on the floor that both ducts are the same length.

## 5 Making Service Connections from the System to the Wall Plate

Refer to Fig. 9

Remove ALL OF THE POLYTHENE CAPS protecting the screw threads of the fittings mounted on the boiler and wallplate. The layout

of the services and their position is given in Fig. 9. Note that the: HEATING FLOW AND RETURN SOCKETS ARE 22 mm COPPER;

GAS SUPPLY SOCKET IS 22 mm COPPER;

DOMESTIC HOT WATER MAINS INLET SOCKET IS 15 mm COPPER;

DOMESTIC HOT WATER SERVICE OUTLET SOCKET IS 15 mm COPPER.

All are labelled clearly.

The isolation valves for heating flow and return and the domestic service are supplied.

Before the boiler is mounted on the wall plate the water and gas services need to be connected to the back of the wall plate using the union elbows, washers, sockets provided.

Check that all other fixings have been made in accordance with Fig. 9.

Washers are provided in two polythene bags, suitably labelled, to ensure water soundness at each union connection. ENSURE THE WASHERS AND THE GAS COCK 'O' RING SEAL ARE FITTED. THEN REFER TO SECTION 6.

The main gas cock complete with fittings for connection to the appliance is packed in a polythene bag.

When all the external service pipework has been connected to the rear of the wall plate lower cross bar. FLUSH THE SYSTEM, and ensure it is completely free of debris, such as flux, solder, etc.

Remove boiler from its packaging to prepare for mounting onto the wall mounting plate, then remove white casing. This is retained by a pozipan head screw at the top left and right hand side. Remove the screws and lift off the casing.

Remove the guard plate and put to one side (Fig. 13) by: Removing the M5 hexagon head screws retaining the left hand and right hand ends of the panel to allow the panel to be removed. NOTE:- If necessary an expansion vessel may need to be fitted with the boiler. See page 9.

## 6 Hanging the Boiler on the Wall Plate and Making Service Connections to the Boiler

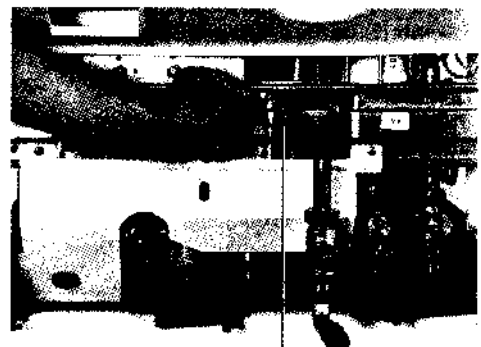
NOTE:- A two men lift may be required.

Refer to Fig. 12 and REMOVE THE RED PLASTIC PLUG protecting the gas valve inlet connection.

1 Offer the boiler up to the wall plate and hang it on the TWO projecting support lugs provided at the left and right hand ends of the upper cross bar. Refer Fig. 8. A key hole slot is cut into the return edge of the boiler left and right hand side panels, near the top, for this purpose. The lower cross bar has a centralising lug positioned at the right hand end. ENSURE the slot cut in the return edge of the right hand rear side panel, near the bottom, is engaged with the lug.

2 Before proceeding further ENSURE all lugs are securely engaged and the appliance is firmly in position. Check horizontal and vertical levels.

Fig 12.



oce.9306071025

"O" ring seal

**3 IMPORTANT.** Identify the small polythene bag containing the 'o' ring seal for the main gas cock. Packed also in the small bag are two M5 hexagon head fixing screws for attaching the gas cock outlet flange to the boiler gas valve inlet and ensuring a gas tight seal. Refer to Fig. 12 and 13. Fit the gas cock and pipe assembly to the wall plate lower cross bar by making good the union connection.

Using the two M5 hexagon head screws provided fix tightly the flange of the gas cock to the gas valve inlet.

**THE GAS COCK 'O' RING SEAL IS IMPORTANT TO THE SAFE OPERATION OF THE APPLIANCE AND MUST NOT BE OMITTED.**

**4** Make the boiler connections to the heating flow and return; also the domestic hot water mains inlet and service outlet connections fixed to the wall plate.

Note:- Ensure all four connections are made using a fibre sealing washer. A small polythene bag, labelled, containing all necessary washers is supplied.

**5** The safety valve discharge is fitted with a brass elbow having a 15 mm compression fitting pointing to the rear. Ensure a suitably routed 15 mm dia. copper discharge pipe is fitted from the elbow to a safe drain point. The pipe **MUST** be fitted so that the guard plate (Fig. 12) can be removed for servicing and any steam or liquid will discharge safely i.e. the pipe shall terminate such that any discharge from it causes no hazard either to persons, property or electrical installations within or outside the appliance casing. Ensure the pipe is routed so that after testing during servicing (section 8.8) it cannot retain water. Insulate the pipe to inhibit freezing during cold weather.

**6** The end of the duct with restrictor ring fitted is firmly pushed over the turret flue outlet and fixed with a single M5 pozidrive screw as shown in Fig. 10. After ensuring the air duct 'o' ring seal and the air duct locking ring are correctly positioned, push the plastic air duct fully home into the turret air inlet socket, and tighten the locking ring by screwing it onto the threaded portion of the turret with a clockwise rotation.

**7 DO NOT USE TOOLS TO TIGHTEN THE LOCKING RING. TIGHTEN BY HAND UNTIL SECURE.**

Make good the brickwork around the hole in the outer wall face, if necessary. **USING THE STAINLESS STEEL SEALING RING AND MASTIC SUPPLIED IN THE STANDARD FLUE KIT CARTON** seal the gaps between the hole in the outer wall face, the stainless steel ring and the air duct. Refer to Fig. 10. Ensure a water tight joint by pushing the stainless steel ring up to the wall face. Seal the gap around the air duct and the inner wall face. When a terminal guard is to be fitted refer to Installation Instructions - Sections 3 and 4. Refer also to Fig. 48.

Make good the brickwork around the hole in the inner wall face, if necessary.

**8** Make all necessary electrical connections to the appliance. Refer to Requirements for Electrical Wiring - Sections 1, 2 and 3.

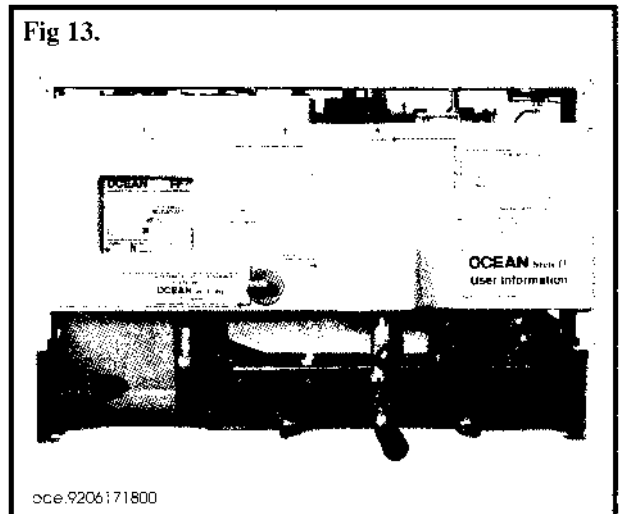
## 7 Commissioning the Appliance

A.

1. The complete gas installation, including the meter **MUST** be purged and tested for gas soundness in accordance with BS 6891:1988.
2. Isolate the electrical supply.
3. Turn off the gas supply at the appliance service cock (Fig. 14.3).
4. Open the central heating flow and return, and the domestic hot water isolation valves (Fig. 9).
5. Loosen the cap of the automatic air vent on the appliance (Fig. 3). Leave it open.
6. Open all radiator valves and system air vents.
7. Fill the system - see REQUIREMENTS FOR SEALED SYSTEMS
8. Check the system for water soundness of the system and appliance.
9. Drain the system, flush, refill and vent. Refill the system to the Initial Design Pressure but do not exceed 1.5 bar.

B (i).

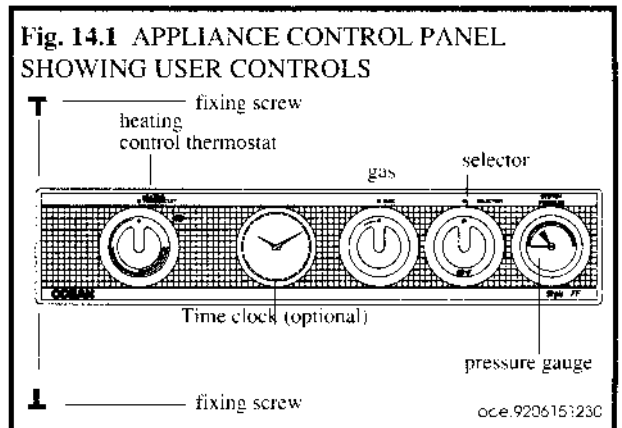
1. Refer to Fig. 14.1.
2. Set the selector to domestic hot water only ( $\frac{H}{F}$ ). Turn on all hot water service taps and allow water to flow until no air is present.



Note that taps must be capable of delivering **INDIVIDUALLY** at least 3 litres/min (0.7 gpm), although a flow rate of 9 to 9.5 litres/min (2 to 2.1 gpm) is recommended. Turn off the taps.

**3.** If it is wished to check the soundness of the pilot supply, this must be done without the main burner alight. Electricity supply must remain isolated.

a) Remove the inner casing front panel via four M5 screws and washers (Fig. 17).



b) Turn on the gas supply at the gas service cock.

c) Fully depress the gas valve knob (Fig. 15.1) and hold in. Allow the pilot pipe to purge then apply a lighted taper or match to the pilot burner (Fig. 15.1).

d) When lit, hold in the gas valve knob for a further 10 seconds, then release and the pilot should remain alight. If the pilot is extinguished at this or any other time wait at least 3 minutes before attempting to relight.

e) Check for gas soundness of the pilot pipe connections using leak detection fluid.

f) Check that the pilot flame is correct (Fig. 15.3). If necessary, adjust the length via the pilot adjustment screw (fig. 15.1). Screwing clockwise reduces the flame length.

Note: The normal thermocouple closed circuit voltage range is 8 mV to 12 mV.

g) Leave the pilot alight but **REPLACE THE INNER FRONT PANEL.**

**4.** Loosen the burner setting pressure test point screw (Fig. 15.1) and attach a pressure gauge.

**5.** Set any external controls to call for heat.

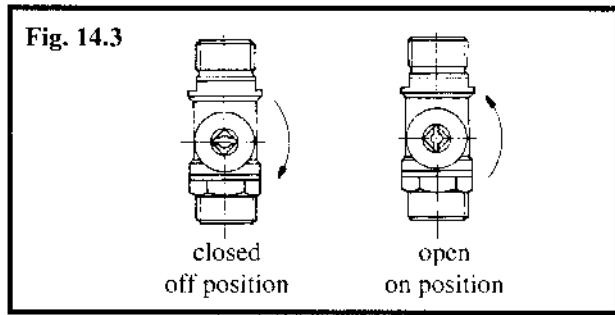
**6.** Using a screwdriver, carefully prise off the heating thermostat control knob (Fig. 14.1).

**7.** Remove the two outer screws revealed (not the inner screws).

**8.** From underneath and behind, push off the selector knob (Fig. 14.1).

**9.** Remove the four control panel facia fixing screws and remove the facia (Fig. 14.1). Take care not to damage the pressure gauge capillary tube.

10. Temporarily refit the heating thermostat control and selector knobs.



B (ii).  
To install optional time clock see page 11 and 12.

**C. CHECKING/ADJUSTING THE HEAT INPUT/BURNER PRESSURES.**

Note: Adjustments must be made in the order given.  
The maximum Domestic Hot Water input is factory set to 29.7 kW. Although the burner pressure should be checked, adjustment should not be necessary unless the central heating input is changed.

The Central Heating input is factory set to 19.2 kW, but this can be adjusted to suit the system requirements between the values given in Table 1. The setting must be between 16.5 and 23.1 kW input. It will also be necessary to check that the low setting on Domestic Hot Water (which coincides with the central heating input) can be obtained.

Note that prolonged running without an electrical supply may result in the pilot flame being extinguished - relight if necessary.

**C.1. DOMESTIC HOT WATER - MAXIMUM INPUT**

- Selector knob set to Domestic Hot Water Only (H) (identify from fascia panel).
- Hot water tap fully open.
- Switch on the electricity supply.
- If the pilot is alight, the main burner will light. Immediately check that the burner pressure is as given in Table 1 (13.9 mbar).
- If adjustment is required, using a 10 mm blade screwdriver, adjust the spindle A, Fig. 15.2 (counter clockwise to decrease). The prescribed pressure must not be exceeded.
- Turn the hot water tap off and on a few times and ensure that the pressure indicated remains correct.
- Isolate the electrical supply.
- Close all hot water taps.

Note: Any adjustment of spindle A will result in the central heating setting, which has been factory set, being altered.

**C.2. CENTRAL HEATING - FIXED INPUT**

- Selector knob set to Domestic Hot Water + central heating (H+H).
- Heating thermostat to maximum.
- System controls calling for heat, all radiator valves, if fitted, fully open.
- Switch on the electricity supply. If the pilot is alight, the main burner will light. After about 10 minutes, check the burner pressure.
- Adjust the burner pressure to the required value, using a 3.5 mm blade screwdriver, via screw B, Fig. 15.2. DO NOT ALLOW THE SPINDLE A TO MOVE.

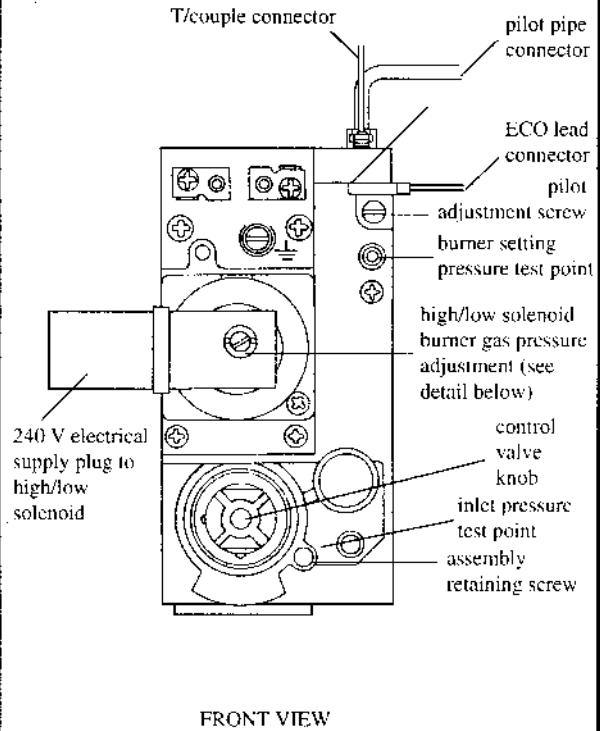
**C.3. RECHECKS**

- Recheck the Maximum Domestic Hot Water Setting as described in C1 above.
- Note that each time the Domestic Hot Water setting is adjusted, the central heating setting must be rechecked.

**C.4. DOMESTIC HOT WATER - MINIMUM INPUT**

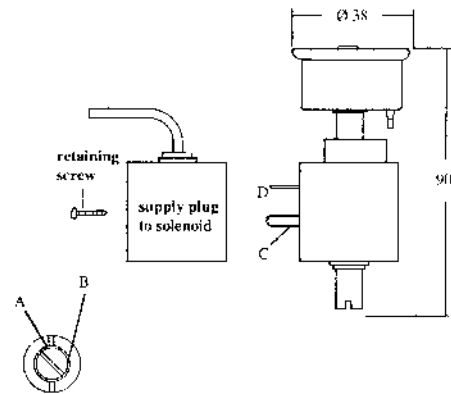
- Isolate the electricity supply.
- Remove the plug from the HIGH/LOW solenoid valve (screw, Fig. 15.2). Place safely as the plug will be live for the following check.
- Selector knob to Domestic Hot Water Only (H).
- Hot water tap fully open.
- Electricity supply on.

**Fig. 15.1. GAS CONTROL VALVE - ADJUSTMENTS**

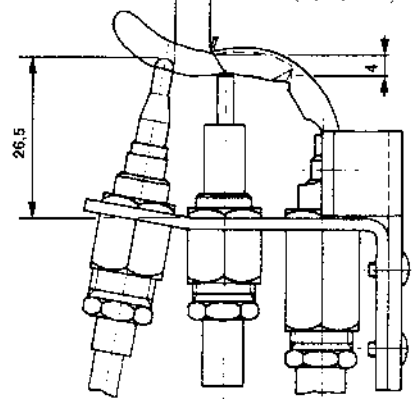


**Fig. 15.2. DETAIL OF HIGH/LOW SOLENOID**

- A:- adjustment screw for maximum pressure setting
  - B:- adjustment screw for minimum pressure setting
  - C:- 6.3 mm amp terminals
  - D:- earth terminal
- high/low solenoid



**Fig. 15.3. PILOT FLAME LENGTH (10-13 mm)**



The pressure should be the same as set for Central Heating. Adjustment is not possible - refer to Fault Finding if the setting is incorrect.

#### D. COMPLETION

1. Isolate the electricity supply.
2. Refit the HIGH/LOW solenoid valve plug.
3. Remove the pressure gauge and retighten the test point screw, ensuring a gas tight seat.
4. Remove the heating thermostat and selector knobs.
5. Refit the control panel facia, securing with a total of six screws.
6. Refit the knobs.

## 8 Checking Operation of the Central Heating / Domestic Hot Water Services and Safety Valve

NOTE:- If power to the appliance is switched off for any length of time, it may be necessary to relight the pilot.

1 Set the control thermostat to OFF and the service selector knob to central heating and domestic hot water. Turn the control thermostat to maximum; the burner should light and the burner pressure should stabilise at the (LOW) setting after a few minutes.

2 Turn on a tap so that the flow rate is approximately 9 l/min (2 gpm). Use a suitable measuring device to check the flow rate. When the tap is turned on the burner pressure should rise to the (HIGH) gas pressure setting and remain steady.

The water temperature should begin to rise and depending upon the flow rate and cold water inlet temperature settle down to between 40°C and 50°C.

Reduce the rate at which water is drawn off gradually until water temperature rises to between 60°C and 70°C, when the gas pressure should fall from HIGH to LOW and then commence to switch between HIGH and LOW as the water temperature rises and falls. Further reduce the rate of draw off gradually until water temperature rises to between 70°C and 80°C when the burner should switch off, then commence to switch on and off as water temperature rises and falls.

Note:- The minimum domestic hot water draw off rate is 3l/min (0.7 gpm) below which the appliance will not operate.

Reverse the procedure above and check each stage of operation ie. switching between HIGH/LOW gas pressure at intermediate water flow rates and operation at HIGH gas pressure when flow reaches maximum draw off rate.

3 Set the service selector knob to domestic hot water only. Check that the maximum flow rate can be obtained. When completed turn off the tap when the burner should extinguish.

Turn the tap on and off at 10 seconds intervals two or three times and check burner ignition and shut down.

Turn off the tap. Set the service selector knob to central heating and domestic hot water.

The burner should extinguish and provided the timer and any heating controls are calling for heat the burner will relight at LOW gas pressure setting.

4 Operate the appliance on central heating service and allow the system to warm up. Check the system is heating up evenly and then turn the control thermostatic knob towards its minimum setting. Observe the burner to extinguish. Turn the thermostat knob towards its maximum setting when the burner should relight. Repeat the procedure once more.

5 If the heating system is fitted with thermostatic radiator valves AND A BYPASS then proceed to make the following adjustments. IF A BYPASS IS NOT REQUIRED:

ie. an uncontrolled radiator of minimum catalogue rating 1.2 kW (4,100 Btu/h) is fitted, proceed to Section 8.7 below.

Provided the heating system has been designed to take account of the AVAILABLE PUMP HEAD FOR HEATING SYSTEMS - Table 4 - page 6, the pump energy should ensure a temperature difference across the boiler flow and return pipes of 17 °C (20°F) maximum. However, the setting pressure should be matched to maximum heating load when all thermostatically controlled radiator valves are fully open and the BYPASS CLOSED. The central heating system should be heated up from cold under this condition for at least 15 minutes. Ensure any time clock or room thermostat fitted cannot cause the boiler to switch off. When adjusting the bypass it is important to ensure the boiler is firing continuously, as cycling of the boiler control thermostat gives a false impression of the temperature difference.

Using a contact thermometer balance the system if required. If the

circulating pump is fitted with a speed adjustment it will be factory preset at maximum. DO NOT ADJUST.

Check the temperature difference across the boiler flow/return pipes (A & B Fig 16). Provided the available pump head has not been exceeded (refer Table 4) the temperature difference will be below 17 °C (20°F).

SEE NOTE BELOW. Check the temperature difference ACROSS THE SYSTEM ie. ACROSS THE FLOW AND RETURN PIPES UPSTREAM OF THE BYPASS (C & D Fig. 16). Open the bypass lock shield valve slowly until the temperature difference across the system is 17 °C (20°F).

NOTE:- If the available pump head has been exceeded the bypass should be left CLOSED.

An uncontrolled radiator of catalogue rating 1.2 kW (4,100 Btu/h) MINIMUM should be chosen from within the system to act as a suitable source of heat dissipation. The appliance should NOT be operated at a flow rate less than 9.86 l/min (2.17 gpm).

7 Balance the system if required.

Check operation of the time switch and room thermostat if fitted. Isolate the appliance at the wall socket or isolation switch. Set any timer and heating controls to OFF. Set the boiler control thermostat to OFF.

Replace the white outer casing using the reverse of the procedure under Section 5.

NOTE:- The two fixing screws provided MUST be refitted.

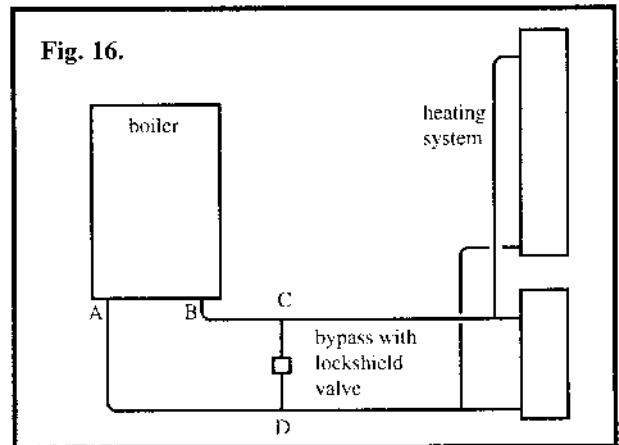
IMPORTANT:- If the factory setting on the central heating gas pressure has been altered during commissioning refer to the data plate, positioned UNDER THE APPLIANCE, FIXED TO THE CONTROLS SUPPORT PLATE.

RESET the indicator arrow, which will be set against the factory preset output of 14.1 kW (48,000 Btu/h). Move the arrow to indicate clearly the revised central heating output. Tighten the fixing screw with the arrow in its new position.

8 Check the operation of the safety valve. Refer to Fig. 1 and Installation of the Appliance - Section 6.5. Test by turning the safety valve knob anticlockwise half a turn and then releasing, quickly. The valve should discharge and reseal itself without leaking.

9 Replace the guard plate under the boiler by reversing the procedure detailed in Section 5 (Fig. 12).

10 Turn on power at the wall socket or isolation switch. Set the time and heating controls, if fitted, and the service selector knob to the user's requirements. Set the boiler control thermostat to MAXIMUM.



## 9 Instructions Provided for the User

Instruct the user or purchaser of the appliance on the correct operation of the appliance and hot water / heating system.

Hand the User Instructions to the user and ensure he/she understands the procedures required to operate the appliance.

Make sure the user is aware of any precautions necessary to avoid damage to the appliance and heating / domestic hot water system and to the building in the event of the appliance and system being in operation during frost conditions.

Advise the user of the need to ensure safe and efficient operation of the appliance and system by regular servicing. The appliance should be serviced by A COMPETENT PERSON AT LEAST ONCE EVERY TWELVE MONTHS, or at intervals recommended by the local Gas Region.

If further advice or assistance is required relating to servicing contact Argos Building and Heating Supplies Ltd.

# SERVICING THE APPLIANCE

## 1 Annual Servicing - Routine Inspection and Cleaning

To ensure continued efficient operation of the appliance it is recommended that it is checked and serviced as necessary at regular intervals. The frequency of servicing will depend upon the particular installation conditions and usage but in general once per year should be adequate. It is the law that any service work **MUST** be carried out by a competent person such as British Gas or other Corgi registered personnel.

1. The following items should then be cleaned or checked for signs of deterioration before being replaced, if necessary.

a) Note any faults in the operation of the appliance when operated as described under Section 2 below.

b) Examine and clean the pilot burner assembly: pilot injector, spark electrode, thermocouple.

c) Examine and clean the main burner assembly: injector and injector manifold.

d) Observe the condition of the combustion chamber insulation.

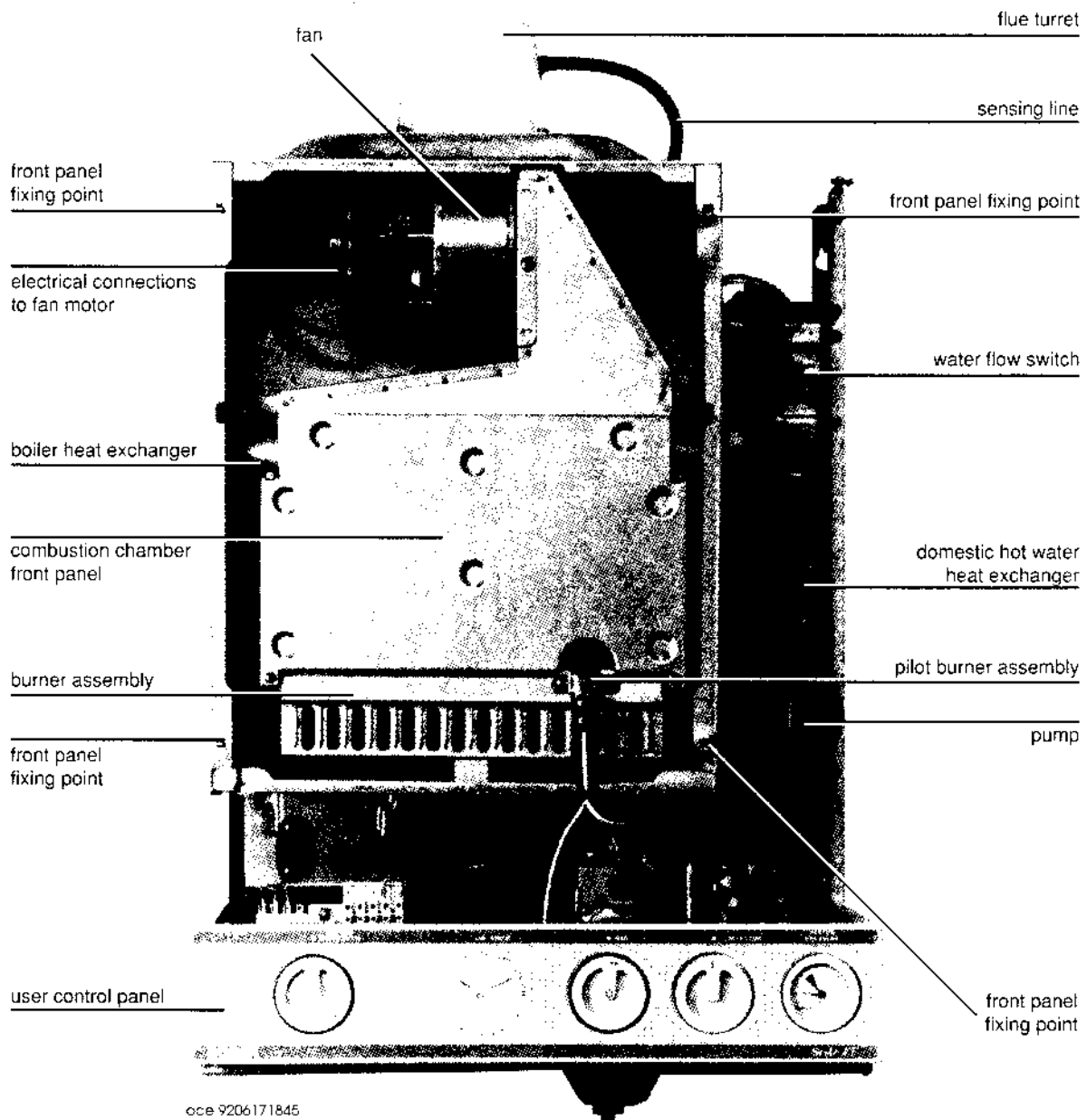
e) Examine and if necessary clean the heat exchanger.

f) Examine and if necessary clean the fan.

g) Examine the flue system both internally and externally. Ensure there is no blockage of either the air or flue ducts and that the flue terminal is unobstructed. Check the external air duct locking ring is secure and the air duct is built into the inner wall face solidly. Check the fixing screws connecting the flue turret to the top of the appliance for tightness.

h) When the appliance has been fitted inside a compartment the ventilation areas required should be checked and cleared of any obstruction. If necessary **BRING TO THE USER'S ATTENTION THE NEED TO ENSURE** the ventilation openings are kept free of obstruction.

**Fig. 17. FRONT VIEW WITH WHITE OUTER CASING AND INNER FRONT PANEL REMOVED.**  
NOTE:- SERVICING SHOULD BE UNDERTAKEN BY A COMPETENT PERSON ONLY.



oce 9206171845

## 2 Checks Undertaken Prior to Servicing

a) Remove the white outer casing by unscrewing the pozipan head screws located on the top left and right hand sides. Lift and pull casing forward.

b) Operate the appliance by undertaking the normal lighting procedure from cold. Follow the instructions on the hinged plate under the boiler. Turn knob quarter turn clockwise to release.

Allow the central heating system to warm up and check both central heating and domestic hot water services. Observe the operation of the boiler and controls. Note any faults which will need to be rectified during servicing.

**IMPORTANT:- ISOLATE THE MAINS ELECTRICAL SUPPLY AT THE WALL SOCKET OR SWITCH BEFORE ATTEMPTING TO SERVICE THE APPLIANCE.**

Note:- There are warning notices attached to the appliance pointing out actions necessary for safety. DO NOT REMOVE OR DEFACE ANY WARNING NOTICE.

c) Ensure the gas supply is turned OFF at the gas cock. When service work has been completed gas soundness should always be checked using gas soundness fluid. Recommission the appliance in accordance with the procedure detailed under Installation of the Appliance - Section 7.

## 3 Tools to Undertake Servicing

The following tools will assist in servicing and replacing all appliance components.

Note:- The list includes basic "off the shelf" items and is not intended to preclude the use of alternative specialised tools which may save time.

### LIST OF MINIMUM REQUIRED TOOLS FOR SERVICING

ALLEN KEYS: 4 mm and 5 mm.

SPANNERS OPEN ENDED: 7; 8; 9; 10; 11; 12; 17; 22; 24; 26; 37; 39 mm.

N° 2 POZIDRIVE SCREWDRIVER WITH PLASTIC HANDLE LENGTH OF SHAFT 250 mm.

N° 2 POZIDRIVE SCREWDRIVER WITH PLASTIC HANDLE LENGTH OF SHAFT 100-130 mm.

N° 2 POZIDRIVE SCREWDRIVER WITH PLASTIC HANDLE - STUBBY.

N° 3 POZIDRIVE SCREWDRIVER WITH PLASTIC HANDLE LENGTH OF SHAFT 100-130 mm.

N° 3 POZIDRIVE SCREWDRIVER WITH PLASTIC HANDLE - STUBBY.

LIGHT ELECTRICIAN'S TYPE SCREWDRIVER FOR SLOTTED HEADSCREWS - SHAFT 100 mm - BLADE WIDTH 3 mm.

CABINET SCREWDRIVER FOR SLOTTED HEADSCREWS (PLASTIC HANDLE) - SHAFT 100-130 mm - BLADE WIDTH 4-5 mm.

CABINET SCREWDRIVER FOR SLOTTED HEADSCREWS (PLASTIC HANDLE) - STUBBY - BLADE WIDTH 4-5 mm.

CABINET SCREWDRIVER FOR SLOTTED HEADSCREWS (PLASTIC HANDLE) - SHAFT 200-220 mm - BLADE WIDTH 8-10 mm.

PLIERS 6" LONG NOSED WITH PLASTIC HANDLES. SIDE CUT WITH SERRATED JAWS.

ADJUSTABLE SPANNERS - 6" AND 10". BACHO OR SIMILAR MOLE WRENCH 8".

STILSON WRENCH 14".

## 4 Servicing of Components

**NOTE THE REPLACEMENT OF COMPONENTS IS DETAILED IN SECTION 5 - page 27.**

**1 Removal of inner casing front panel.** Fig 17 page 24.

Remove the inner casing front panel by unscrewing the four M5 pozidrive screws positioned one at each corner. RETAIN the countersunk washers and fibre washers.

**2 Removal of combustion chamber front panel.** Fig. 17

Remove the two M4 pozidrive screws at the bottom left and right hand side of the panel: retain them. Grasp the panel at both sides and slide it down about 10 mm to disengage the locating lugs situated at the top left and right hand sides. The inner face of the panel is lined with insulating material. Pull the panel forward to disengage it. Take care not to allow the insulation pad to fall out.

**3 Removal of the pilot burner assembly.** Fig. 17, 18.

Using a 9 mm open ended spanner remove the thermocouple capillary connector on top of the gas valve. Pull out the ECO lead connection. Refer Fig. 15 and Fig. 34.

a) Unscrew the aluminium pilot pipe connection at the gas valve using an 11 mm spanner.

b) Remove the two M4 pozidrive screws at the left and right hand side of the pilot assembly mounting bracket - attaching the bracket to the main burner assembly.

c) Pull the assembly forward - complete with pilot pipe, electrode lead and thermocouple attached, until the synthetic rubber sealing gasket is clear of the slot into which it is engaged as shown in fig. 18 below.

d) Hold the assembly by hand or by a suitable tool, such as a mole wrench.

Using a 10 mm open ended spanner unscrew the union connector at the base of the thermocouple. Pull the thermocouple out of its retaining socket. Take care not to damage the synthetic rubber sealing gasket. (Fig. 18).

Using a pair of long nosed pliers pull the electrode lead off the push on connector at the bottom of the electrode (Fig 18).

Use the 10 mm open ended spanner to unscrew the union connector at the bottom of the electrode (Fig. 18). Be careful to retain the brass connector. Pull the electrode out of its retaining socket.

Use the 10 mm open ended spanner to unscrew the union connector fixing the aluminium pilot pipe to the pilot assembly. The pilot injector is positioned immediately behind the union connector. Take care when removing the connector. Place the injector and aluminium pilot pipe complete with silicone rubber gasket to one side.

e) Examine the thermocouple. If it shows signs of deterioration replace it.

Examine the electrode lead, particularly the point where it is connected to the electrode. Look also for chafing of the lead. If necessary replace it.

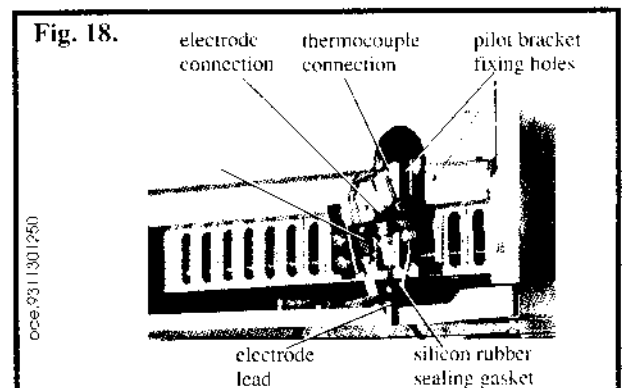
Examine the electrode for damage to the insulation or tip. If damaged replace it.

Examine the pilot injector for damage. Make sure it is free of any foreign matter. If necessary blow through with air. Replace it if damaged in any way.

Examine the pilot shield and pilot assembly in general. If any damage has been sustained, replace it.

Examine the pilot pipe. Ensure it is not kinked and both union connections are in good condition.

NOTES:- As a matter of routine all components should be cleaned of any foreign matter or debris before reassembling.



Examine the synthetic rubber gasket for signs of deterioration. If necessary replace it.

Reassemble in reverse order. Care should be taken not to damage the silicone rubber gasket. Push both the electrode and thermocouple fully home into their respective retaining sockets

before tightening the union connectors. Ensure the pilot injector is replaced correctly when refitting the aluminium pilot pipe.

Finally refer to Fig. 15 and check the correct dimensional relationship exists between the individual components. DO NOT refit the pilot burner assembly to the main burner assembly at this stage.

#### 4 Removal of the burner assembly (Fig 19).

The burner assembly is supported both at the front, by means of a fixing bracket, and at the rear on lugs fixed to the left and right hand ends of the injector manifold.

a) Remove the single pozidrive screw retaining the burner front support bracket.

b) Pull the burner assembly forward about 10 mm. This will disengage it from the lugs. It can then be removed from the combustion chamber. Refer Fig. 19 and Fig. 20.

Individual burner blades may be removed from the frame by pulling out the two retaining rods from the right hand end of the assembly. Once the rods are removed the bars may be eased out by grasping at both ends and lifting upwards.

c) Using a brush with non-metallic bristles carefully brush the flame parts and remove any debris from within. Any blade showing signs of deterioration should be replaced on reassembly.

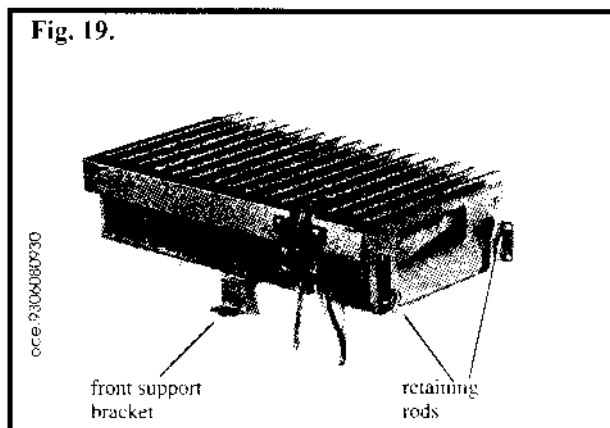
Remove any debris from within the frame of the burner assembly. Ensure all flame ports are clean before reassembling in reverse order.

Note:- The design of all burner blades is identical. It is not necessary to replace them in any particular order.

Ensure each bar is positioned with its venturi inlet lined up with the appropriate hole at the BACK of the frame. All bars should be parallel and pushed as far as possible towards the rear of the frame. Incorrect fitting or misalignment will make it impossible to refit the two retaining rods, which should be pushed fully home. Having reassembled the main burners put the assembly to one side.

#### 5 Removal of injector manifold (Fig. 20).

Using an adjustable spanner slacken the union connection positioned underneath the injector manifold. Remove the four pozidrive screws, two at each end which attach the manifold to the appliance back panel. (Refer Fig. 20).



Unscrew the union connection completely and lift the injector manifold out of the combustion chamber. If necessary remove injectors using a 7 mm spanner and check there is no blockage or damage. Refit the injectors and their washers.

#### 6 Combustion chamber insulation (Fig. 20).

Examine the combustion chamber insulation not forgetting the insulated combustion chamber front panel removed previously. Look for flaking or mechanical breakdown and if necessary replace the insulation.

#### 7 Removal of fan (Fig. 10 and Fig. 17).

If the general appearance of the combustion chamber / heat exchanger / flame picture is unsatisfactory it is advisable to remove and clean the fan.

Remove the fan electrical leads by pulling off the line and neutral insulated connectors at the fan motor.

Unscrew the nut at the earthing stud using a 13 mm open ended spanner. Remove the earth-lead and shake proof washer. Retain

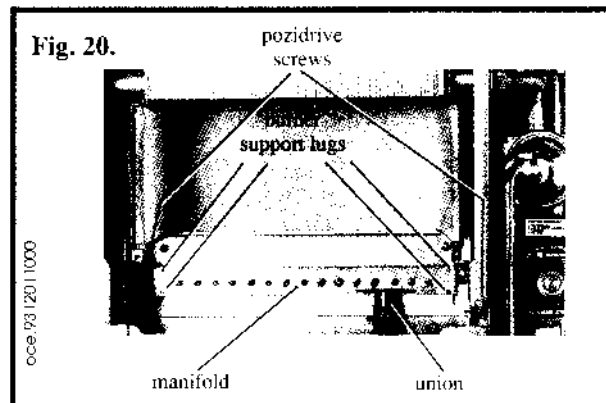
the nut and washer for reassembly.

Note:- On reassembly, polarity of the line and neutral leads is not important when refitting the insulated push on connectors.

DO NOT OMIT THE EARTH LEAD CONNECTION TO THE FAN. Examine the sensing line and check it is not twisted or damaged in any way. Replace if necessary. Using an 8 mm open ended spanner or cabinet screwdriver remove the four M5 hexagon head screws positioned at each corner of the flue turret.

Unscrew the pozidrive screws securing the end of the fan mounting plate to the front face of the smokehood. Slide the fan assembly forward (towards the front of the appliance) until the retaining lugs at the opposite end of the plate are disengaged from the slots in the smokehood.

Twist the fan body through 90° in a clockwise direction.



The fan body can now be removed out of the front opening of the fan compartment.

NOTE:- THE SEALING GASKET POSITIONED BETWEEN THE FAN OUTLET AND THE UNDERSIDE OF THE FLUE TURRET MUST BE RENEWED ON REASSEMBLY, IF DAMAGED.

CLEAN THE FAN. The fan should be cleaned using a soft brush only. Do not use sharp instruments which may damage the fan. All dirt and dust should be removed from the motor, impellor and impellor housing.

If available, blowing with compressed air is permissible.

When cleaned place the fan assembly to one side.

#### 8 Cleaning the heat exchanger (Fig. 17).

First remove the collector hood by lifting it to unseat it from the top of the heat exchanger. Move it to the right sufficiently to position the top immediately behind the small cutout in the return edge of the top panel.

Slide the collector hood forward and clear of the fan compartment. Cover the open end of the gas manifold connection.

Examine the heat exchanger carefully. If necessary clean the fins using a suitable brush from above and below.

TAKE CARE NOT TO DAMAGE THE COMBUSTION CHAMBER INSULATION.

Any debris which has fallen down into the base of the boiler body should now be removed together with the cover over the gas manifold connection before reassembly.

#### Reassembly

Reassemble the components in the following order reversing the procedure used to remove them from the appliance.

Collector hood and fan assembly, THEN FIX THE TURRET CORRECTLY BEFORE REFIXING; air duct; sensing line, fan electrical leads; injector manifold; burner assembly; pilot burner assembly. DO NOT OMIT THE PILOT PIPE CONNECTION TO THE GAS VALVE; fit combustion chamber front panel. DO NOT FIT THE INNER FRONT PANEL. BEFORE PROCEEDING TO RECOMMISSION THE APPLIANCE (Refer to Installing the Appliance - Section 7). OBSERVE THE DATA PLATE POSITIONED UNDER THE BOILER ON THE CONTROLS SUPPORT PLATE.

Although the appliance is preset at 14.1 kW (40,000 Btu/h) central heating and 23.4 kW (80,000 Btu/h) domestic hot water output, the central heating output may have been changed during the original commissioning. The central heating service gas pressure should be set to that indicated by the pointer, attached to the data plate. The domestic hot water service gas pressure should be set to achieve 23.4 kW (80,000 Btu/h).

### 9. Examination of domestic hot water filter

If when recommissioning the appliance (Section 7) and checking maximum DHW flow rate at a tap there appears to be a loss of water pressure, this may be due to dirt in DHW filter.

The filter should be examined and removed/cleaned or renewed as necessary. Access the filter as follows:

- Turn off DHW cold inlet isolation valve.
- Open a hot tap to drain down DHW in the pipes.
- Slacken nut on base of mains water inlet valve and remove draining any residual water into a suitable receptacle.
- Remove filter from base of valve.
- If the filter requires cleaning, wash thoroughly to remove any debris and replace in position - OPEN END FACING UPWARDS WITH HOLE IN FILTER POINTING TOWARDS WALL PLATE.
- If the filter is damaged renew it.

Reassemble in reverse order.

Recheck domestic hot water flow rate at tap.

Examination of the central heating water filter.

On commissioning of the boiler if it appears the pump is working but the boiler does not fire up as the water flow switch has not been proved it is possible there may be dirt in the central heating filter.

The filter should be examined and removed/cleaned or renewed as necessary. Access to the filter is as follows:

- Turn off the central heating flow and return isolation valve.
- Attach a small rubber pipe to the central heating return valve drain off cock open the valve draining any residual water into a suitable receptacle.
- Slacken nut on base of valve draining any further residual water into suitable receptacle.
- Remove filter from base of valve.
- If the filter requires cleaning wash thoroughly and remove any debris and replace it in position - OPEN END FACING UPWARDS WITH HOLE IN FILTER POINTING TOWARDS WALLPLATE.
- If the filter is damaged renew it.

Reassemble in the reverse order.

Refill heating system using filling loop and vent pump via screw at the front. Recheck boiler to ensure flow switch is now operating.

### 10 Examination of the Water Flow Restrictor (if fitted) and Venturi.

a) Remove the right-hand pipe connection from the top of the pressure sensor proceed as per removal of the left-hand pipe as detailed in section 9.

b) With the pipe removed it is possible to see the flow restrictor but for its removal access must be gained into the venturi housing below. Do not prise or lever out the restrictor as this could result in damage to the restrictor housing.

c) Remove the plug retaining clip and shown in fig. 40 and remove the plastic plug from the front of the pressure sensor.

WARNING: There is a small spring within the venturi assembly and care should be taken when removing the plug.

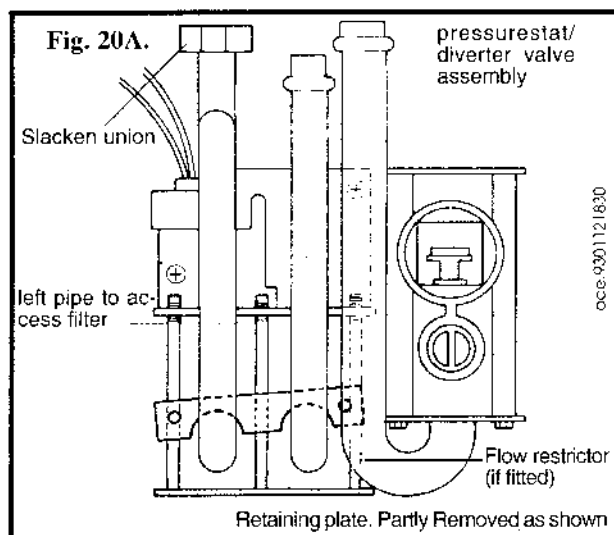
d) With the venturi assembly removed and using bent nosed pliers or similar tool ease the restrictor upward out of its housing.

e) Clean and inspect both the water flow restrictor and the venturi, if either is damaged, replace.

Reassemble in the reverse order using new O-ring seals at the pipe entry ports.

### 11 Examination of the Main Diaphragm.

a) Remove the front control panel as detailed in 5.3



b) Remove both the left and right hand pipes from the top of the pressure sensor as detailed in sections 9 & 10

c) Remove the 6 x m5 hexagon headed bolts that secure the pressure sensor to the diverter valve.

d) Once the bolts are released the two sections of the pressure sensor together with the main diaphragm can be removed.

e) Clean and inspect the main diaphragm for damage, if suspect or damaged replace.

Reassemble in the reverse order using new O-ring seals at the pipe entry ports.

NOTE: When assembling the main diaphragm, the circular indentation points to the rear of the pressure sensor.

## 5 Replacement of Component Parts

NOTE:- COMPONENT PARTS SHOULD BE REPLACED BY A COMPETENT PERSON ONLY

IMPORTANT:- ISOLATE THE MAINS ELECTRICAL SUPPLY AT THE WALL SOCKET OR SWITCH BEFORE ATTEMPTING TO REPLACE COMPONENT PARTS.

There are various warning notices attached to the appliance pointing out actions necessary for safety. DO NOT REMOVE OR DEFACE ANY WARNING NOTICE. Ensure the gas supply is turned off at the service cock. When a component(s) has been replaced and the appliance reassembled ALWAYS undertake a gas soundness check using gas leakage detection fluid - when it has been necessary to break a gas joint. Recommission the appliance in accordance with the procedure detailed under Installation of the appliance. Section 7.

Section 5 - Index.

5.1 (a) Outer casing - for access

(b) Removal of combustion chamber front panel

5.2 (a) Pilot burner assembly

(b) Thermocouple

(c) Electrode lead

(d) Electrode

(e) Pilot injector

(f) Rubber sealing gasket

(g) Fan

(h) Main burner

(i) Injectors

(j) Front panel viewing window

5.3 (a) Clock (if fitted)

(b) Suppressor

(c) Relay

(d) Fan resistor

(e) Spark generator

(f) (i) Control thermostat

(ii) Safety thermostat and Domestic Hot Water thermostat

5.4 Overheat thermostat

5.5 Air pressure switch

5.6 Ignition control microswitches

5.7 Gas valve

5.8 Combustion chamber insulation

5.9 (a) Water flow switch

(b) Euramo Gold Star / Grundfos 15/60 circulating pump

(c) Domestic Hot Water heat exchanger

(d) Microswitch cover assembly and Domestic Hot Water pressure stat/diverter valve

(e) Central Heating expansion vessel

(f) Safety valve

(g) Domestic Hot Water expansion vessel (if fitted)

(h) Pressure gauge

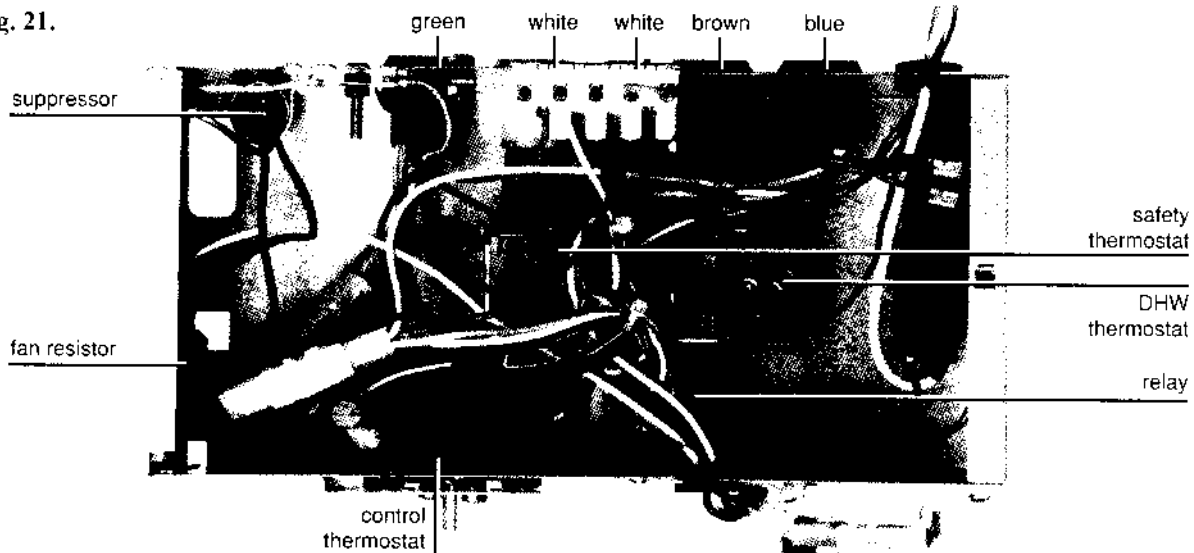
(j) Heat exchanger

5.1. Remove the white outer casing by unscrewing the pozipan head screws located on the top and lifting and pulling the casing forward.

a) Remove the inner front panel (Fig. 17) by unscrewing the four M5 pozidrive screws positioned one at each corner.

b) Remove the combustion chamber front panel (Fig. 17) by unscrewing the two M4 pozidrive screws at the bottom left and right hand sides of the panel. Grasp the panel at both sides and slide it down about 10 mm to disengage the locating lugs situated at the top left and right hand sides. Pull the panel forward to disengage it. Take care not to allow the insulation pad to fall out.

Fig. 21.



oce.9256180900

5.2 REPLACEMENT OF THERMOCOUPLE - ELECTRODE LEAD - ELECTRODE - PILOT INJECTOR - PILOT BURNER BRACKET ASSEMBLY WITH SHIELD - SILICONE RUBBER SEALING GASKET - FAN - MAIN BURNER - INJECTORS - VIEWING WINDOW. Refer to 5.1 above for procedures (a) to (k).

**a) Pilot burner assembly**

Remove the pilot burner assembly complete with thermocouple, ignitor lead and pilot pipe attached, by following the procedure detailed under Section 4.3 (a); (b); (c).

**b) Thermocouple replacement**

Remove pilot burner assembly (5.2a)

Using a 10 mm open ended spanner unscrew the union connector at the base of the thermocouple head. Pull the thermocouple head out of its retaining socket. Take care not to damage the rubber sealing gasket (Fig. 18).

Pass the head of the thermocouple through the slot in the rubber gasket. NOTE:- If the gasket is damaged it must be replaced on reassembly. Ensure the gasket is correctly fitted.

Fit a new thermocouple by reversing the procedure above. Ensure the ECO circuit connector is fully home at the gas valve before tightening the thermocouple union connector. Ensure the thermocouple head is pushed fully home into its socket before tightening the union connector at the pilot assembly end.

**c) Electrode lead replacement**

Remove pilot burner assembly (5.2a)

Using a pair of long nosed pliers pull the electrode lead off the connector at the bottom of the electrode (Fig. 18).

Withdraw the lead through the rubber gasket.

i) Refer to Fig. 21 and Fig. 14. In order to gain access to the control box remove the control thermostat knob. Insert the blade of a stubby flat bladed screwdriver behind the edge of the knob and carefully lever off the shaft. This will expose two pozidrive fixing screws attaching the control panel to the control box behind it. Remove the two screws. DO NOT REMOVE THE TWO INNER SCREWS which attach the control thermostat to the control box.

ii) The service selector knob is then removed by pushing it off its shaft using finger pressure from behind the control panel. Slacken the two pozidrive screws located at the right hand side of the control panel (top and bottom). Remove the two pozidrive screws located at the left hand side of the control panel (top and bottom). The left hand side of the control panel may now be pulled forward and swung to the right sufficiently to gain access to the control box. Take care not to damage the pressure gauge capillary tube, immediately behind the gauge. Release the catch holding the hinged plate under the boiler (Fig. 12). Turn the knob quarter turn clockwise to release and swing the plate forward.

iii) Remove the single pozidrive screw positioned under the control

box, fixing it to the main controls support plate. Pull the control box forward to improve access. Remove the single pozidrive screws retaining the cover on top of the control box. Remove the cover. The spark generator is positioned at the right hand side of the control box (Fig. 20). Using a pair of long nosed pliers pull the lead off its connector at the spark generator. Remove the lead through the grommet at the rear of the control box. REPLACE the lead and reassemble using the reverse procedure.

**d) Electrode replacement**

Remove the thermocouple head ONLY from the pilot burner assembly using the procedure in 5.2 (b). Using a pair of long nosed pliers pull the electrode lead off the push on connector at the bottom of the electrode (Fig. 18).

Using a 10 mm. spanner unscrew the union connector at the base of the electrode. Push the electrode out of its retaining socket. Replace with a new electrode - ensuring it is pushed fully home into its socket before fitting and tightening the union connector. Reassemble in reverse order. Finally make sure the electrode tip has the correct relationship with the pilot shield and thermocouple. Refer to Fig. 15.

**e) Pilot injector replacement**

Remove the thermocouple head ONLY from the pilot burner assembly (5.2b). Then disconnect the ignitor lead and remove the electrode (5.2d).

Using a 10 mm. spanner unscrew the pilot pipe union connector at the base of the pilot burner. The pilot injector is positioned inside the socket and may FALL OUT unless care is taken in removing the pilot pipe union connector.

Remove the pilot injector. Fit a new pilot injector and reassemble in reverse order. Check the pilot pipe connections for gas soundness using leakage detection fluid. Refer Section 7.7 - and Fig. 15.

**f) Pilot burner bracket assembly with shield and synthetic rubber gasket-replacement**

Follow the procedure under Section 5.2. When the pilot injector has been removed from the pilot burner bracket assembly, the assembly can be discarded and a new one fitted. If the rubber sealing gasket is to be replaced the old gasket may be cut away or released from the thermocouple head, ignitor lead and pilot pipe by passing them through the centre of the gasket. Do not cut the new gasket.

**g) Replacement of fan (Fig. 17) Refer to 5.1**

Remove the fan electrical leads by pulling off the line and neutral insulated connections at the fan motor.

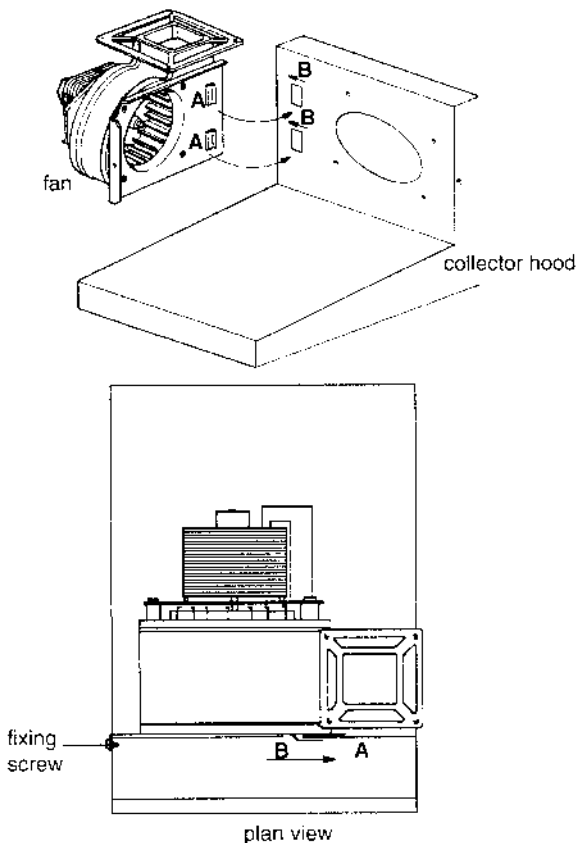
Unscrew the nut at the earthing stud using a 7 mm spanner. Remove the earth lead and shake proof washer.

Note:- Polarity of the line and neutral connections is not important when fitting the insulated push on connectors.

THE FAN MUST BE EARTHED HOWEVER.

**Fig. 22a.**

Detail of fanbody/collector hood location



Note: - Tabs (A) slot inside holes (B).  
Push back fan body until return on fan mounting plate meets collector hood. Fix with single pozidrive screw.

Using an 8 mm spanner or cabinet screwdriver remove the four M5 hexagon head screws positioned at each corner of the flue turret. Unscrew the pozidrive screws securing the end of the fan mounting plate to the front face of the collector hood. Slide the fan assembly forward (towards the front of the appliance) until the retaining lugs at the opposite end of the plate are disengaged from the slots in the collector hood. Twist the fan body through 90° in a clockwise direction. The fan body can now be removed out of the front opening of the fan compartment. (See Fig. 22a over)  
NOTE:- THE SEALING GASKET POSITIONED BETWEEN THE FAN OUTLET AND THE UNDERSIDE OF THE FLUE TURRET MUST BE RENEWED ON REASSEMBLY. (SUPPLIED WITH FAN)

#### **h) Replacement of main burner**

Refer to 5.1

Remove the pilot burner assembly (5.2a)

Remove the burner (4.4 (a); (b))

Replace the burner and reassemble in reverse order.

#### **i) Replacement of injector manifold / injectors**

Remove main burner (5.2 above).

Remove injector manifold / injectors (5.5)

Replace manifold / injectors and washers as necessary.

Reassemble in reverse order.

#### **j) Replacement of front panel viewing window**

If the front panel viewing window requires replacement a complete inner front panel - complete with window should be obtained and fitted.

Contact Argos building and Heating Supplies Ltd. (Part N° 5607482/1)

### **5.3 REPLACEMENT OF CONTROL BOX COMPONENTS**

Use the procedures from 5.2c (i) to (iii) to gain access to the control box ONLY. DO NOT proceed past the instruction to move the

control forward to improve access. Refer to Fig. 21.

When a component(s) has been replaced refix the control box top cover first using the single pozidrive screw at the top, then refit the complete control box to the controls support plate using the single pozidrive screw from the underside.

Now reassemble the control panel using the reverse of the procedure detailed under section 5.2c (i) and (ii).

NOTE:- ON REASSEMBLY BOTH CONTROL THERMOSTAT AND SERVICE SELECTOR KNOBS ARE SIMPLY PUSHED ONTO THEIR RESPECTIVE SHAFTS.

#### **a) Replacement of time clock.**

As for installation see page 11 and 12

#### **b) Suppressor replacement**

Remove earth wire from brass earth stud by pulling spade from terminal. Remove both black wires from connector.

Unscrew suppressor bracket; remove suppressor and leads complete. Replace new suppressor using reverse procedure.

#### **c) Replacement of relay (Fig. 21)**

Remove the four insulated connectors from the top of the relay. Remove the pozidrive screw fixing the relay to the front of the control box from the front.

Replace the relay and reassemble in reverse order, taking care to ensure correct wiring connections are made (Fig. 24).

NOTE:- \* The two yellow coded connections made to relay can be placed on either of the specified terminals.

\*\* The two grey coded connections made to relay MUST BE REPLACED AS FOLLOWS:-

Care should be taken and the source of the grey wires checked before reconnecting them.

One grey connecting wire is linked with its blue plug at the rear of the control box and the other to the green plug.

#### **d) Fan resistor replacement**

Refer Fig. 21. Pull off the insulated connectors at each end of the fan resistor body.

Remove the two M3 screws and nuts fixing the resistor body to the front panel of the control box.

Renew the resistor. NOTE, the polarity is immaterial but the connections should be remade without imposing any strain on them.

Reassemble in reverse order.

#### **e) Spark Generator replacement**

Refer to Fig. 21.

Using a pair of long nosed pliers pull the electrode lead off its connector at the generator. Remove the two insulated connectors. Remove the single M3 pozidrive screw nut and washer fixing the spark generator to the right hand side panel of the control box. Fit a new generator ensuring the earth lead is under the fixing nut and washer; refit the insulated connectors; ensuring correct wiring (Fig. 25).

Refit the electrode lead and reassemble in reverse order.

#### **f) Control thermostat; safety thermostat and domestic hot water thermostat replacement**

NOTE:- In order to improve access within the control box, remove relay complete with insulated connectors attached, by unscrewing the pozidrive screw at the front of the control box. Remove the two insulated push on connectors from the fan resistor. Refer to Fig. 21 and Fig. 24. Move relay to the rear and refer to Fig. 26.

NOTE:- The grommet shown in Fig. 26 is split and a small slot is cut adjacent to the grommet hole in the back of the control box to facilitate removal of the thermostats.

NOTE:- The unlabelled terminals of the top LHS of the DHW and SAFETY THERMOSTATS ARE NOT USED.

#### **i) Control thermostat replacement**

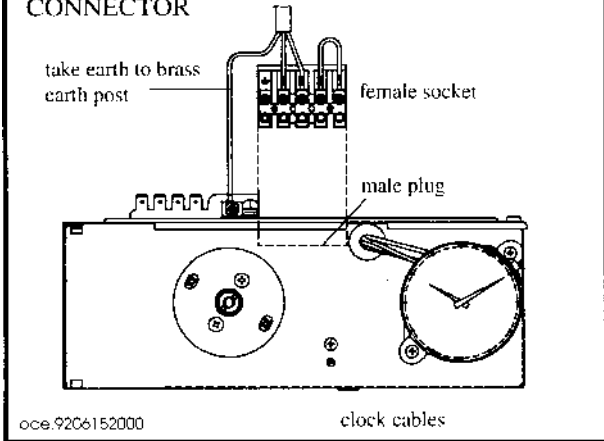
Fig. 26, Fig. 27 and Fig. 32.

The phial is clamped to the side of the boiler flow pipe.

Using finger pressure remove the spring steel retaining clip clamping the phial to the pipe.

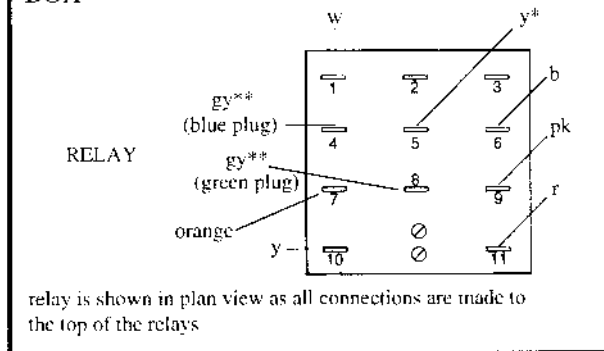
Note:- On reassembly ensure the phial is positioned in the centre of the groove indented in the pipe.

**Fig. 23. CONTROL BOX ELECTRICAL SUPPLY CONNECTOR**



A packet of heat sink compound is provided with the replacement thermostat which **MUST** be smeared into the groove on the pipe. Note the thermostat capillary route from the thermostat body to the phial. Remove the three insulated connectors from the push on connections on the thermostat body (Fig. 26). Remove the two pozidrive screws on the front face of the control box, attaching the thermostat body. Disconnect the ignitor lead at the ignitor (Fig. 25). Withdraw it from the control box through the grommet at the rear. Withdraw the capillary tube and phial from behind the control box and gas valve. Remove the thermostat body from inside the control box and feed the full length of the capillary tube in from behind the control box, through the grommet. Finally, feed the phial itself in through the grommet. When renewing the thermostat ensure the capillary tube is not kinked or tangled with other components.

**Fig. 24. COLOUR CODED WIRING CONNECTIONS TO THE RELAY WITHIN THE CONTROL BOX**

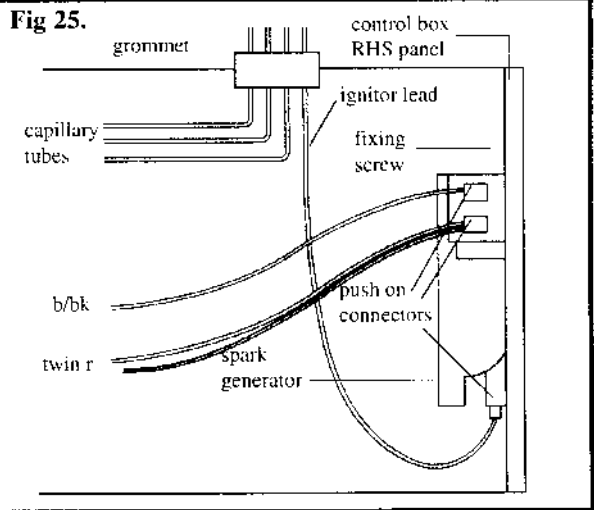


Route it behind the gas valve.  
**DO NOT FORGET TO REPLACE THE IGNITOR LEAD.**  
**REASSEMBLE IN REVERSE ORDER.** (Connect thermostat as Fig. 26)  
 After completing refitment of the control thermostat, replace relay and **ENSURE** the insulated connectors to it are secure and in the correct position (Fig. 24). Replace fan resistor leads

**ii) Safety thermostat or domestic hot water thermostat replacement**

Identify the respective thermostat phial pocket with phial inserted and the thermostat body. (Fig. 26, Fig. 28 and Fig. 29). Remove the spring clip retaining the phial. Ensure there is sufficient length of capillary to avoid strain.  
**NOTE:-** A sachet of heat sink compound is provided with the replacement thermostat, which **MUST** be smeared on the thermostat phial and inside the phial pocket.  
 Note the thermostat capillary route from the thermostat body to the phial.

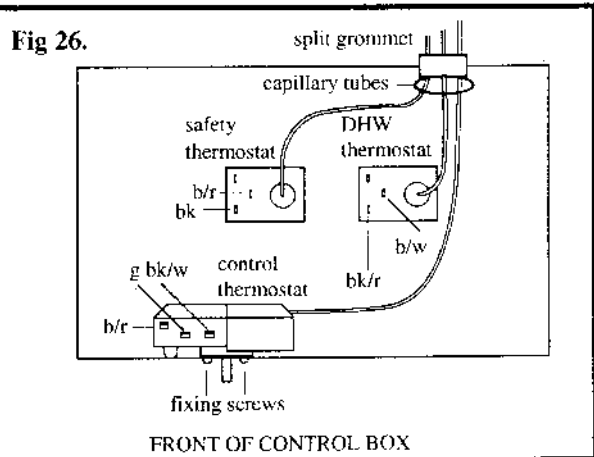
Pull off the two insulated connectors at the thermostat body (Fig. 26). Using a 14 mm. spanner remove the single nut on the under side of the control box which fixes the thermostat body to the control box base. Disconnect the electrode lead from the spark generator (Fig. 25) and withdraw it through the control box and through the grommet at the rear. Withdraw the capillary tube and phial from behind the control box and gas valve. Remove the thermostat body from inside the control box and feed the full length of the capillary tube out from behind the control box through the grommet. Finally, feed the phial itself in through the grommet. When renewing the thermostat ensure the capillary tube is not kinked or tangled with other components. Route it behind the gas valve.  
**DO NOT FORGET TO REPLACE THE IGNITOR LEAD.**  
**REASSEMBLE IN REVERSE ORDER.**  
 After completing refitment of the safety or domestic hot water thermostat, replace relay and **ENSURE** the insulated connectors



are secure and in the correct position (Fig. 24). Replace fan resistor leads.

**5.4 REPLACEMENT OF OVERHEAT THERMOSTAT**

The overheat thermostat is of the surface mounted type and is fixed to a small plate positioned on the boiler flow pipe (RHS) just after the point where the pipe is connected to the heat exchanger. (Fig. 30)  
 The electrical cut out leads (ECO) are permanently attached to the thermostat at one end (Fig. 30). The opposite ends of the leads are connected (a) to the rear face of the gas valve (Fig. 31) below and (b) the top of the gas valve (Fig. 15) and (Fig. 36).  
 Remove the hinged panel and guard plate under the boiler. Refer to Section 5 (Fig. 12)  
 Remove the grey plastic cover over the mains supply connections to the gas valve by unscrewing the single pozidrive screw.  
 Using a 9 mm. spanner slacken the thermocouple capillary con-

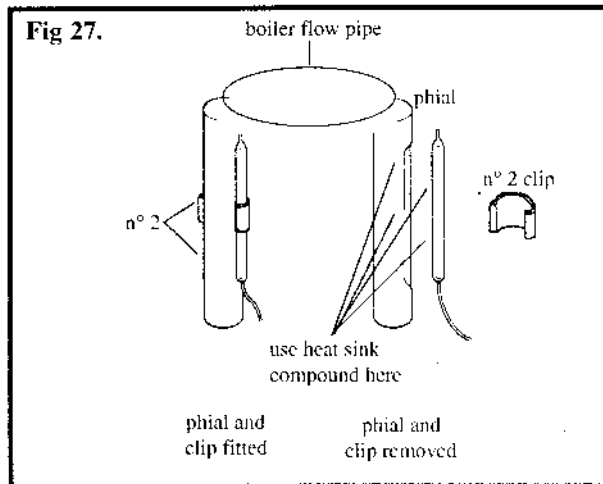


nection on the top of the gas valve sufficiently to pull out the ECO lead connector. Using a 10 mm spanner unscrew the ECO lead connector at the rear of the gas valve.

Remove the two M3 pozidrive screws fixing the thermostat body to the flow pipe mounting plate. Remove the thermostat complete with ECO lead attached. Fit a new thermostat and lead and reassemble using the reverse procedure.

NOTE:- Take care to ensure the ECO leads are securely fixed behind and on top of the gas valve.

A sachet of heat sink compound is provided with the replacement thermostat, which **MUST** be smeared on the face of the thermostat mounting plate.



#### 5.5 REPLACEMENT OF AIR PRESSURE SWITCH (Fig. 32 and Fig. 33).

Remove the plastic sensing tube from the nipple. Examine the tube and if damaged in any way replace it with the switch.

Two M4 pozidrive screws fix the switch and white plastic terminal cover to the cross member. Support the switch and remove the screws. Lift the switch from behind the cross member. Remove the plastic cover to gain access to the switch terminal connectors. Pull off the three insulated connectors at the microswitch.

Remove the switch, renew it and reassemble in reverse order. Ensure correct colour coding of connections (Fig. 33) and positive fixing of air sensing tube at both turret and switch nipples.

#### 5.6 REPLACEMENT OF IGNITION CONTROL MICRO-SWITCHES (Fig. 34); (Fig. 35)

Remove the appliance control panel as follows:- Insert the blade of a stubby flat bladed screwdriver behind the edge of the control thermostat knob and carefully lever off. This will expose two pozidrive screws attaching the control panel to the control box behind it. Remove the two screws. **DO NOT REMOVE THE TWO INNER SCREWS** which attach the control thermostat to the control box. The service selector knob is removed by pushing off its shaft using finger pressure from behind the control panel (top and bottom). Remove the four pozidrive screws (Fig. 14) located at the left and right hand ends of the control panel - two at each end - top and bottom.

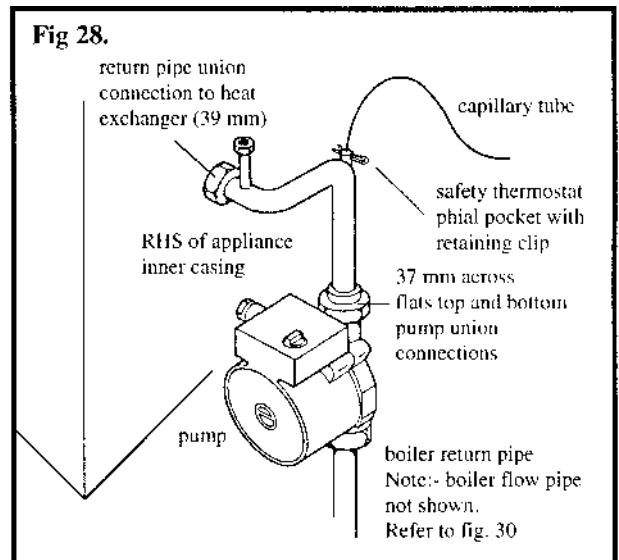
Retain them for reassembly. **TAKE CARE NOT TO DAMAGE THE PRESSURE GAUGE CAPILLARY TUBE.**

The control panel, complete with pressure gauge, can now be pulled forward, off the appliance.

At this stage straighten out the capillary tube still connected to the appliance. Turn the panel over and fix it to the bottom of the lower side panels using two of the original pozidrive screws. Refer to Fig. 34a.

The ignition control microswitch assembly is positioned immediately to the left of the gas valve (Fig. 34). The assembly is removed as follows:-

- a) Remove the pozidrive screw attaching the gas valve control button retaining cover to the valve body. Pull the cover forward off the shaft of the button. Pull the button forward out of its retaining hole and place it to one side.



- b) Detach the microswitch assembly from the gas valve by removing the pozidrive screw attaching the microswitch assembly mounting plate to the underside of the gas valve (Fig. 34).

- c) Remove the M4 pozidrive screw at the back of the assembly outer plastic cover - attaching it to the steel mounting plate (Fig. 35). Remove the mounting plate and cover. Release the single M4 pozidrive screw and remove the plastic inner cover over the switches.

Remove the two microswitches - complete with attached cables by sliding them sideways out of the plastic outer cover.

- d) Pull off the insulated connectors at both switches. Renew the switches and reassemble in reverse order.

**TAKE CARE TO ENSURE** that the latch mechanism is correctly engaged at **BOTH MICROSWITCHES.**

NOTE:- **THE MICROSWITCH LATCH OPERATES THE SWITCHES SIMULTANEOUSLY. WHEN REASSEMBLING IT IS THEREFORE NOT IMPORTANT WHICH CABLE IS ATTACHED TO A PARTICULAR SWITCH.**

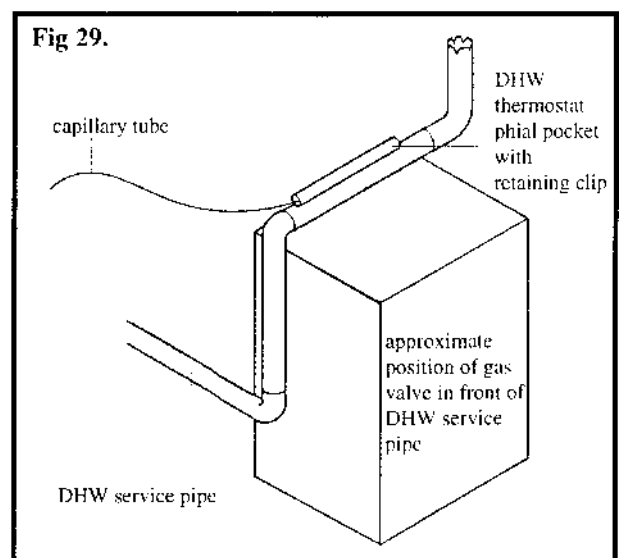
**THE CORRECT COLOUR CODING OF INDIVIDUAL CONNECTIONS IS MOST IMPORTANT HOWEVER (Fig.35).**

Before reattaching the complete assembly to the gas valve, manually operate the latch to check both switches operate simultaneously.

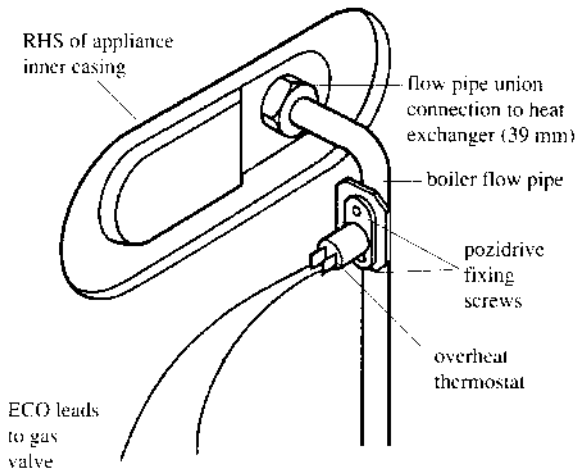
Reassemble the remainder in reverse order.

#### 5.7 REPLACEMENT OF THE GAS VALVE CHECK THE GAS SUPPLY IS TURNED OFF AT THE SERVICE COCK BEFORE PROCEEDING. (Fig. 15); (Fig. 34); (Fig. 36).

- a) Remove the appliance control panel. Refer to Commissioning



**Fig 30.**

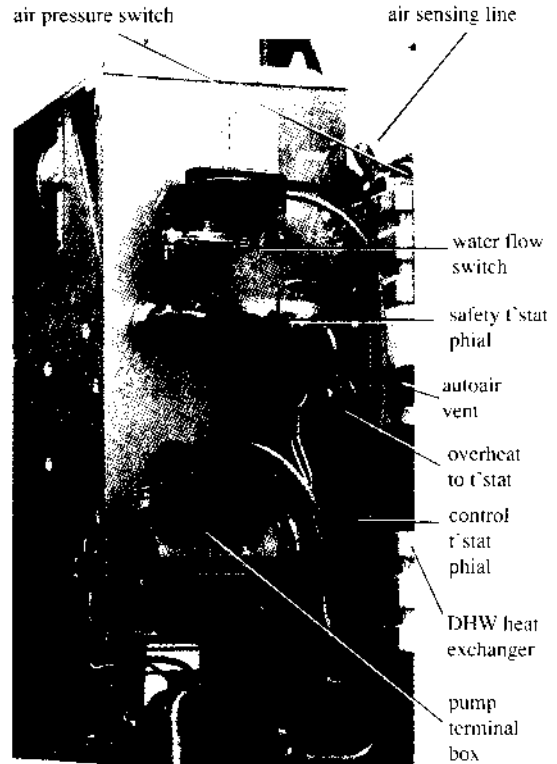


Note:- boiler return pipe not shown. Refer to Fig. 28

**Section.**

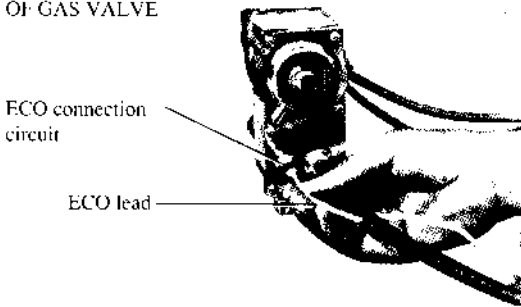
- b) Remove the grey plastic cover over the mains supply connections to the gas valve by unscrewing the single pozidrive screw. Pull off the two push on connections (LINE AND NEUTRAL) and remove the pozidrive screw and washer retaining the EARTH connection to the valve.
- c) Using a 9 mm. spanner slacken the thermocouple capillary connector on top of the gas valve. Pull out the ECO lead connector. Fig. 15 and Fig. 36. Using an 11 mm. spanner remove the pilot pipe union connector at the gas valve.
- d) Slacken the retaining screw at the top of the mains supply plug connected to the HIGH/LOW solenoid valve, sufficiently to allow

**FIG 32.**



oce.9312011030

**FIG 31. REAR FACE OF GAS VALVE**

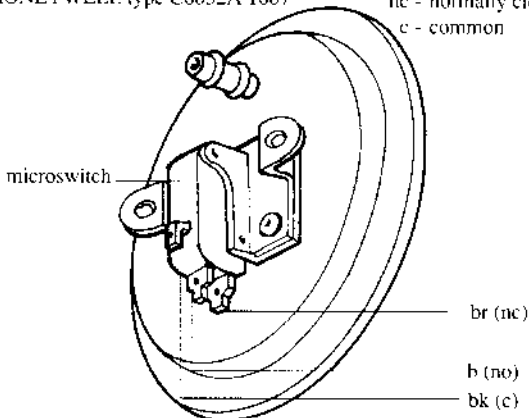


- the plug to be pulled off its connections (Fig. 15). Remove the hinged panel and guard plate under the boiler (Fig. 12). Refer to Section 5. Use a 10 mm spanner to remove the ECO lead union connection at the back of the gas valve. (Fig. 31).
- e) Remove the M5 hexagon head fixing screws attaching the top of the gas valve to the manifold pipe flange. Remove the four M5 hexagon head fixing screws and washers attaching the underside of the gas valve to the controls support plate and gas service cock outlet flange. Remove the 'O' ring seals at the top and bottom of the valve during its removal and RENEW THEM ON REASSEMBLY. The valve body can now be moved forward, clear of the appliance.
- f) Remove the appliance control panel and ignition control mi-

**Fig 33. AIR PRESSURE SWITCH CONNECTIONS (Note there are two alternative types)**

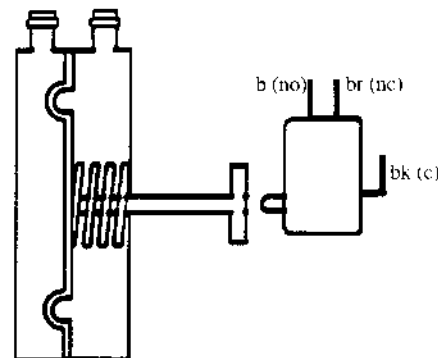
drawing connection for HONEYWELL type C6052A 1007

no - normally open  
nc - normally closed  
c - common

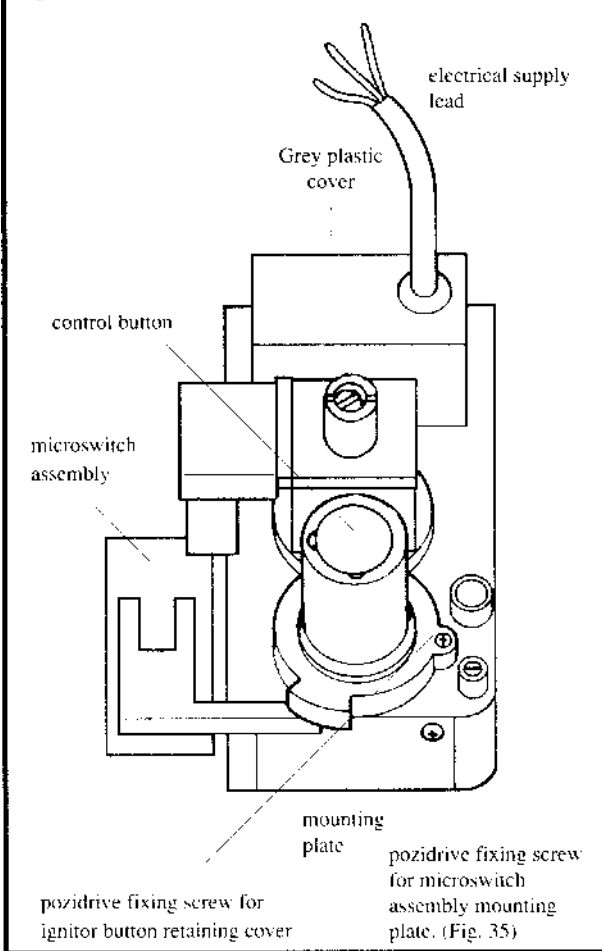


drawing connection for HONEYWELL type C6065A 1010

no - normally open  
nc - normally closed  
c - common



**Fig 34. GAS VALVE BODY LOWER FRONT VIEW**



crosswitch assembly from the gas valve (Section 5.b). Transfer the microswitch assembly to the new valve. Fit the new valve and reassemble in reverse order. Ensure the new 'O' ring seals are positioned correctly at the top and bottom of the valve.

**5.8 REPLACEMENT OF BOILER COMBUSTION CHAMBER INSULATION.**

Refer to Fig. 17 and Fig. 36a.

Remove the burner assembly (Section 4)

(a) Remove the insulation pads A1 (LEFT HAND) AND A2 (RIGHT HAND) by sliding forward out of the combustion chamber

(b) Lower or break out the bottom rear insulation pad by using a screwdriver or similar. Pull down and forward the top insulated panel B2.

Note:- The insulation material is not of high mechanical strength; take care when replacing it.

(c) When replacing, insert panel B2 first and support it in its correct position.

(d) Insert the bottom edge of panel B1 into position under panel B2 and then swing it up, pushing it under the bottom edge of panel B2.

**Fig 34a.**



(e) Panels A1 and A2 can now be fitted.

Slide each panel back until it touches and supports the rear panels. Refer to Fig. 36b. The combustion chamber front panel insulation should now be removed and replaced as shown.

When the new insulation pad is fitted correctly there will be a gap of about 12 mm at each end.

(f) Reassemble the appliance in reverse and undertake gas soundness checks.

**5.9 REPLACEMENT OF COMPONENTS REQUIRING ISOLATION OF THE APPLIANCE FROM THE CENTRAL HEATING (PRIMARY) AND DOMESTIC HOT WATER (SECONDARY) CIRCUITS AND DRAINING OF THE BOILER.**

In order to remove certain components it will be necessary to drain down the appliance. Before attempting to do so.

NOTE: SEALED SYSTEMS MAY BE FILLED COMMISSIONED OR DRAINED BY A COMPETENT PERSON ONLY (Fig. 9)

1. Remove the hinged panel and guard plate under the boiler. Refer to Section 5 (Fig. 12)

2. Turn off the appliance DHW cold inlet isolation valve.

3. Open a hot tap to drain down the DHW pipes.

4. Turn off the appliance central heating flow and return isolation valves.

5. Drain via the system drain cock (see Fig. 3)

**a) Replacement of the Water Flow Switch**

Fig. 32; Fig. 37. Identify the switch positioned at the right hand side of the appliance inner casing, just above the boiler return pipe. Remove the cover from the switch by unscrewing the FOUR pozidrive fixing screws.

Pull off the connectors and remove the supply cable, complete with strain relief bush, away from the area of the switch.

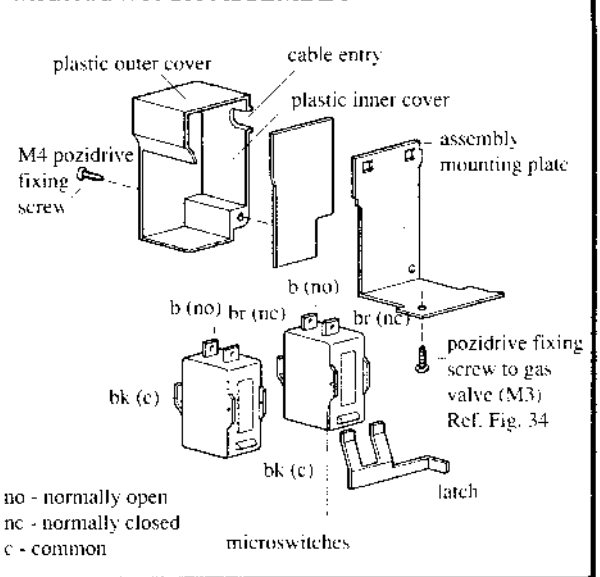
Refer to Fig. 37 and note the TWO union connections, above and below the front of the switch diaphragm, made to the copper sensing pipes.

Using a 17 mm spanner and a 6" adjustable spanner release the top union connection. Support the switch diaphragm and release the bottom union connection.

Remove the plastic switch body complete with diaphragm. Renew the switch assembly, reassembling in reverse order. Check that both union connector sealing washers are fitted. Note:- Ensure the electrical connections and the cable grommet are correctly positioned (Fig. 37). Ensure the cable is adequately clamped when replacing the plastic switch cover.

Before opening the isolation valves and refilling the system - REFER TO PAGE 8 - REQUIREMENTS FOR SEALED SYSTEMS SECTIONS 7 AND 8 and Fig. 3.

**Fig 35. EXPLODED VIEW OF IGNITION MICROSWITCH ASSEMBLY**



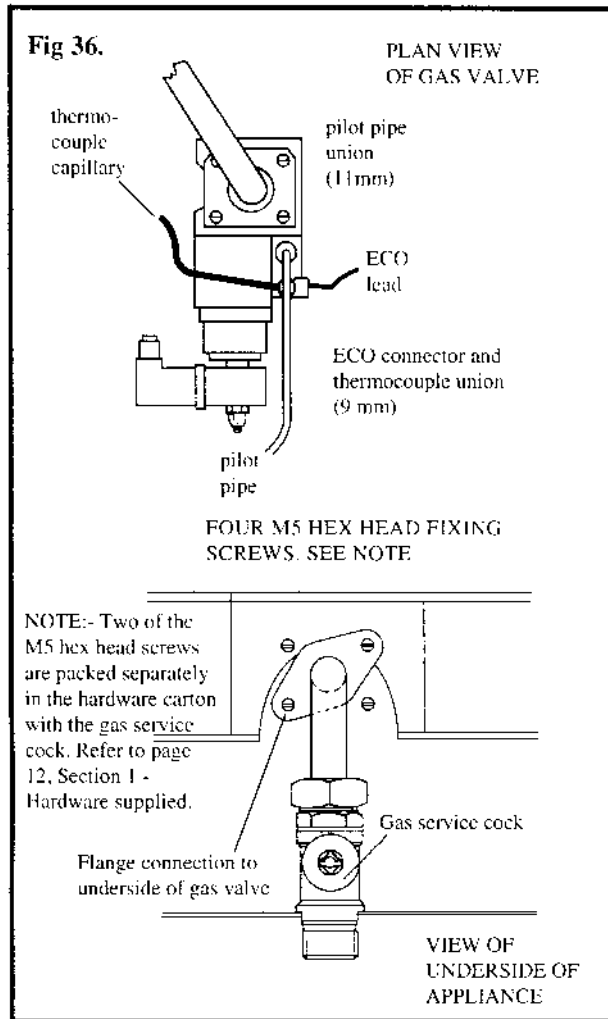
**b (i) Replacement of Circulating Pump - complete**

First remove the appliance control panel.

NOTE:- Before pulling the front panel off the supporting side panels, release the union connector attaching the pressure gauge capillary tube to the appliance return pipe - just below the circulating pump. (Fig. 32), (Fig. 38).

Observe, when releasing the union, there are TWO remaining union connections to the same fitting. They are the water flow switch sensing pipe (RHS) and the connecting pipe from the expansion vessel (REAR). A 6" adjustable spanner may be used to release them. Remove the safety thermostat phial from its pocket. (Section 5.3g (ii))

Release the union connection below the water flow switch diaphragm and then the union connection at the point where the water flow switch sensing pipe joins the appliance return pipe, below the pump. (Fig. 32), (Fig. 37).



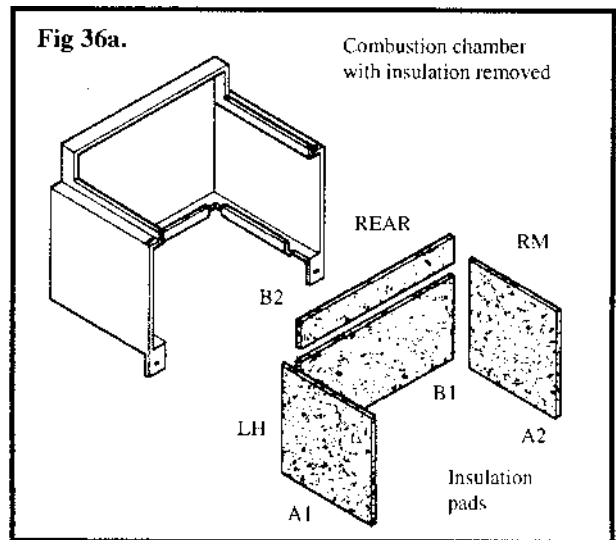
Lift the water flow switch assembly and sensing pipes clear and support it at the rear of the appliance. Now release the remaining union connection at the rear of the fitting.

REFER TO FIG. 38; FIG. 38a; FIG. 40 AND IDENTIFY THE DIVERTING VALVE - BELOW THE PUMP.

Unscrew the TWO M5 hexagon head screws indicated 'A' using an 8 mm spanner and/or a screwdriver, sufficiently to allow the retaining plate to be pulled upwards and released. Put the plate to one side.

Note the plate is held in position within slots at the front and rear. Remove the pozidrive screw retaining the plastic cover over the electrical connections to the pump. Lift off the cover. Remove the three wires connected to the exposed terminal block or pump casing (EARTH) Fig. 38a. Release the union connection at the point where the boiler return pipe enters the heat exchanger, using a 39 mm or adjustable spanner. (Fig. 28).

Grasp the pump and pipework assembly and lift it VERTICALLY



upwards, out of the top of the mixing valve. Using an open ended spanner, release the gland nut clamping the three core electrical cable and withdraw the cable out of the entry hole.

The pipework may now be removed from the pump using a 37 mm spanner in combination with a 14" stilson wrench.

NOTE:- On reassembly, replacement of components will be made easier if the short length of pipe between the top of the diverter valve and the pump inlet is fixed first (Fig. 39). The expansion vessel connection can then be made more easily. The rest of the components, comprising of the pump itself and the short return pipe to the heat exchanger, may then be fitted as a rigid sub-assembly.

Replace the pump using the reverse of the above procedures.

ENSURE:- All sealing washers and 'O' ring seals are renewed and replaced correctly on reassembly. Observe correct polarity when rewiring the pump. Refer to Fig. 38a.

Before the isolation valves and refilling the system - REFER TO PAGE 8 - REQUIREMENTS FOR SEALED SYSTEMS - SECTIONS 7 AND 8 AND FIG. 3.

**b (ii) Replacement of circulating pump - motor only.**

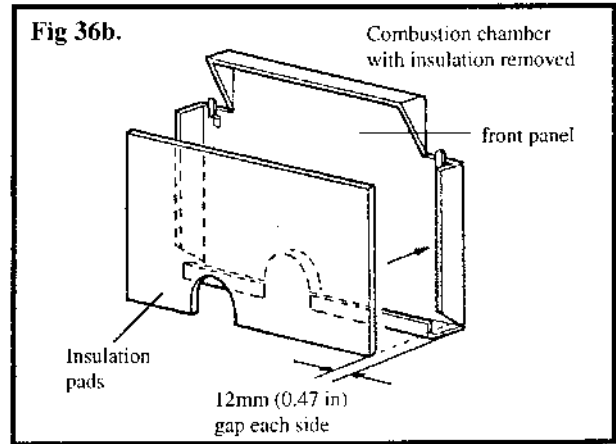
Ensure the boiler is drained down fully. Refer to the figure below. If the Euramo - Gold Star pump is fitted, only TWO socket head screws are used. If the Grundfos 15-60 pump is fitted, four socket head screws are used.

Remove the pozidrive screw retaining the plastic cover over the electrical connections to the pump. Remove the three wires connected to the exposed terminal block of pump casing (EARTH) Fig. 38a.

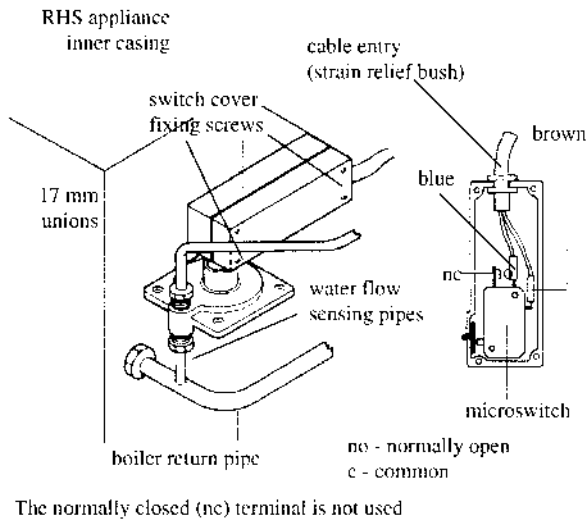
Use a 4 mm allen key to remove the socket head screws attaching the pump motor to the rotor housing. Pull the motor away from the housing; some leverage may be required if the pump has been in situ for some time.

Support the motor. Using an open ended spanner, release the gland nut clamping the three core cable and withdraw the cable out of the entry hole.

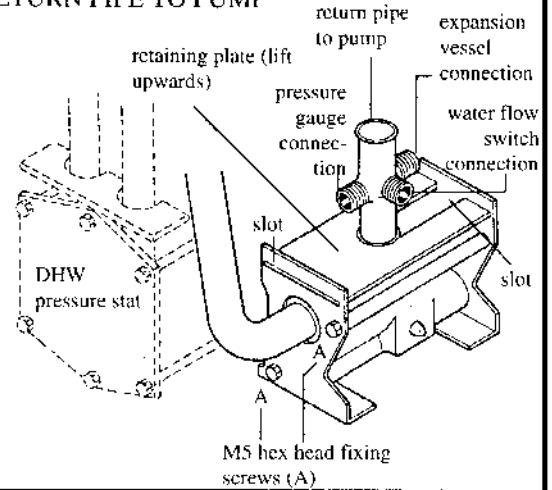
The pump rotor will come away with the motor and is replaced with



**Fig 37. WATER FLOW SWITCH WITH COVER REMOVED**



**Fig 38. THREE WAY DIVERTER VALVE RETURN PIPE TO PUMP**

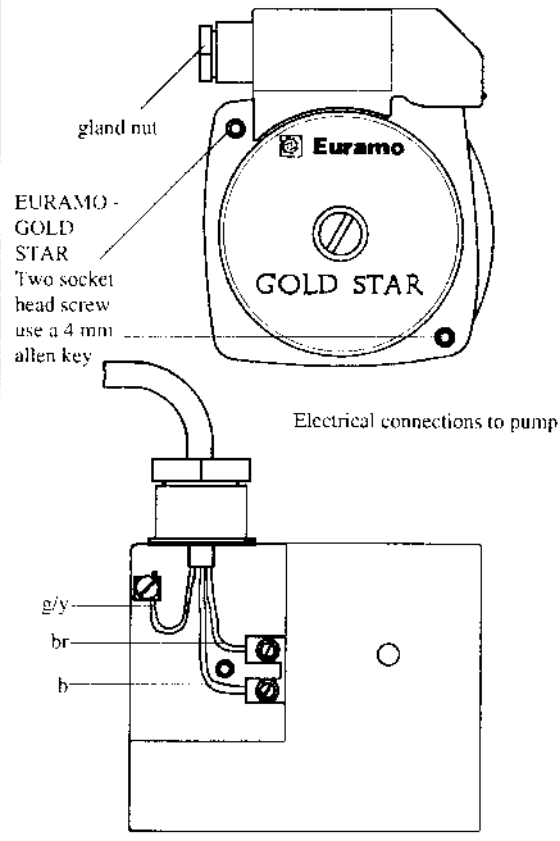


it. Ensure the rotor housing is clean and that the entry and exit ports are free from sludge or hardened deposits.  
 When fitting a new motor / rotor assembly ensure the new 'O' ring seal between the motor and rotor housing is fitted correctly. Reassemble in reverse order; observe polarity when wiring the pump (Fig. 38a)  
 Finally ensure that any pump speed adjustment fitted is set at maximum.  
 Before opening the isolation valves and refilling the system, REFER TO PAGE 8 - REQUIREMENTS FOR SEALED SYSTEMS - SECTIONS 7 AND 8 AND FIG. 3.

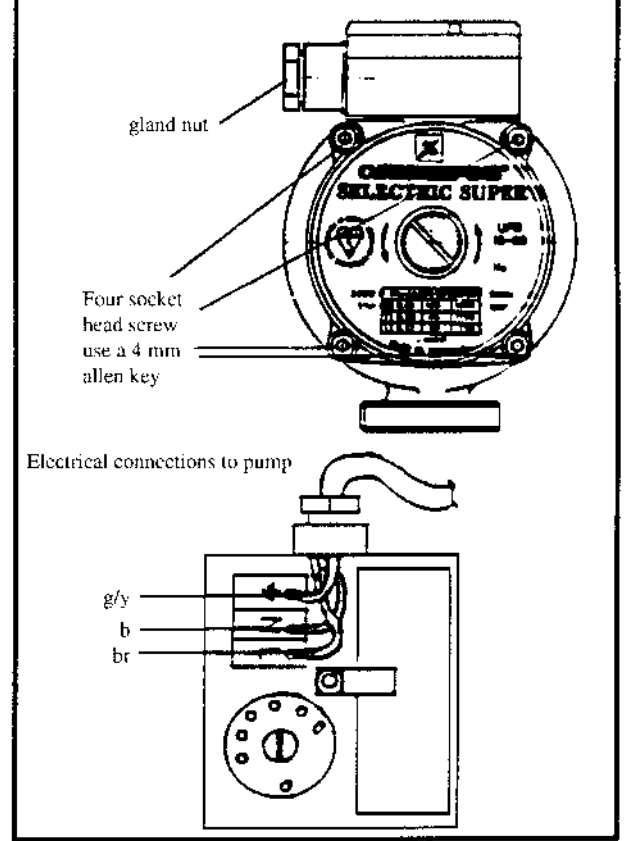
**c) Replacement of Domestic Hot Water Heat Exchanger**  
 Remove stainless steel pressure vessel and connecting pipework

if fitted.  
 Remove the circulating pump complete with connected pipework as detailed in Section 5.9 b (i) - page 34. Place the assembly to one side.  
 Remove the air pressure switch - Section 5.6  
 The heat exchanger, complete with top mounted air vent, is situated at the REAR RIGHT HAND SIDE of the appliance. Identify it and the pipework connections at its base by referring to Fig. 17 and Fig. 39.  
 Remove the control thermostat phial from the boiler flow pipe. Refer Section 5.3g (i). Unscrew the TWO M5 pozidrive screws fixing each retaining plate to the base of the heat exchanger.  
 Remove the plates, complete with screws by means of the small extension lug at the top of each plate.  
 Remove the limit thermostat from the boiler flow pipe by releasing the two pozidrive screws fixing the limit thermostat body to the flow pipe mounting plate. Release the union connecting the boiler flow pipe to the boiler heat exchanger using a 39 mm or adjustable

**Fig 38a. EURAMO GOLDSTAR**



**Fig 38b. GRUNDFOS 15/60**



spanner. Fig. 30.

Unscrew completely the TWO hexagon head screws 'A' retaining the front plate of the diverter valve. DO NOT REMOVE THEM AT THIS STAGE. Refer Fig. 40.

Remove the TWO M5 hexagon head screws 'B' underneath the front plate, attaching it to the controls support plate.

The 'O' ring seals made at the point where each pipe enters the base of the domestic hot water heat exchanger can now be broken by pulling each end forward slightly. Remove the boiler flow pipe by disconnecting the already released union at the boiler heat exchanger.

NOTE:- The pipe joining the domestic hot water heat exchanger to the FRONT plate of the mixing valve has an 'O' ring seal at BOTH ENDS.

Remove the TWO M5 pozidrive screws fixing the domestic hot water heat exchanger to the back of the support member together with the plastic strap. The heat exchanger can now be lifted out VERTICALLY, over the top of the appliance. Replace the heat exchanger using the reverse of the above procedure. Ensure renewal of ALL 'O' ring seals.

Transfer the automatic air vent to the new heat exchanger. Before opening the isolation valves and refilling the system - REFER TO PAGE 8 - REQUIREMENTS FOR SEALED SYSTEMS - SECTION 7 AND 8 and Fig. 3.

**d) Replacement of microswitch cover assembly - domestic hot water pressure stat and diverter valve**

**i) Microswitch cover assembly**

Remove stainless steel pressure vessel and connecting pipework. Remove the circulating pump complete with connected pipework as detailed in Section 5.9 b (i)

Unscrew the M5 pozidrive screw, fixing the LEFT HAND retaining

plate to the base of the domestic hot water heat exchanger. Remove the plate, complete with screws. (Fig. 39)

Release the union connection at the BOILER SIDE of the domestic hot water mains inlet isolation valve. Use a 24 mm or adjustable spanner. (Fig. 9).

Refer to Fig. 41. Using an 8 mm spanner unscrew the TWO M5 hexagon head screws fixing the pipe retaining plate at the top / front of the pressure stat. Then pull the other end of the pipe out of its retaining hole in the pressure stat. Lift off the plate.

Pull the LEFT HAND pipe up, out of its retaining hole in the pressure stat. This will release the pipe.

Pull the RIGHT HAND pipe up, out of its retaining hole in the pressure stat. Pull the other end of the pipe out of its retaining hole in the base of the domestic hot water heat exchanger. This will release the pipe.

Push the remaining pipe slightly and remove the TWO M5 pozidrive screws attaching the microswitch cover assembly to the top of the pressure stat. Lift the assembly slightly to ensure the fixing screws are clear, then remove and retain them.

Lift up the cover assembly and disengage it from the main pressure stat body. Note there are two cable connections to the rear of the cover assembly.

Remove the SINGLE pozidrive screw positioned underneath the control box, which fixes it to the main controls support plate. Pull the control box forward to improve access. Remove the BROWN plug from its socket. Check the route taken by the two cables connected to the brown plug and the microswitch cover assembly. Remove the cover assembly (Fig. 42) by passing the cables and plug behind the gas valve and out over the top of the pressure stat / diverter valve assembly. Replace the component and assemble in reverse order. Before opening the isolation valves and refilling the system - REFER TO PAGE 8 - REQUIREMENTS FOR SEALED SYSTEMS - SECTION 7 and 8 and Fig. 3. Ensure all 'O' ring seals and washers are in place.

**ii) Domestic hot water pressure stat and diverter valve**

Remove the microswitch cover assembly. Section 5.8d (i).

Release the union connection at the BOILER SIDE of the central heating RETURN isolation valve. Use a 30 mm or adjustable spanner.

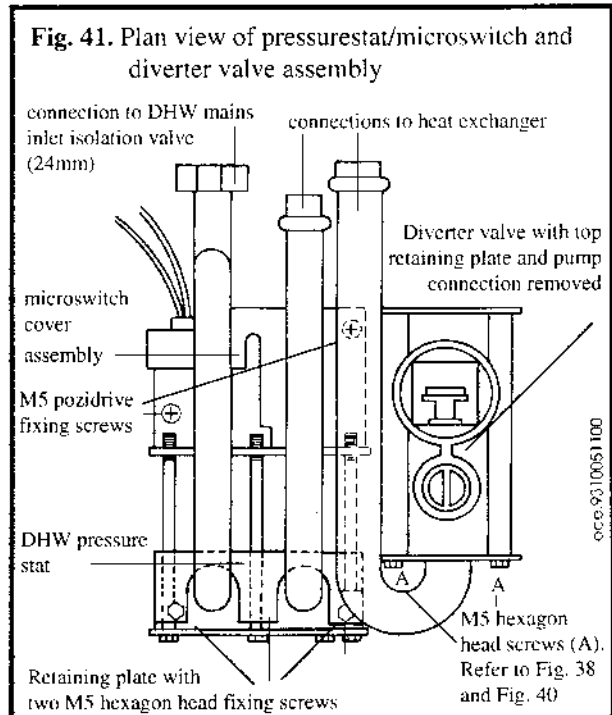
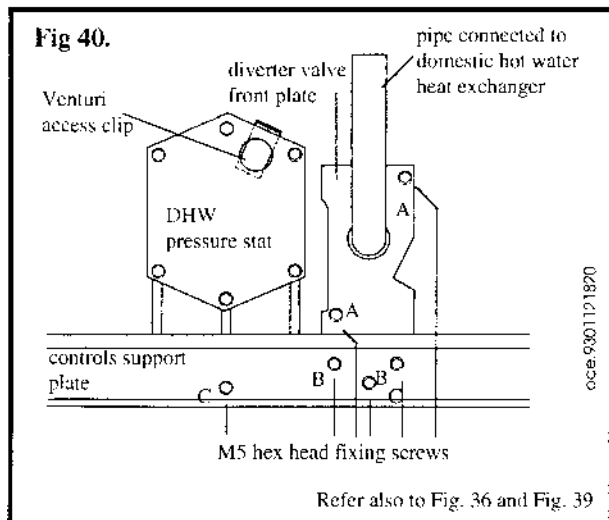
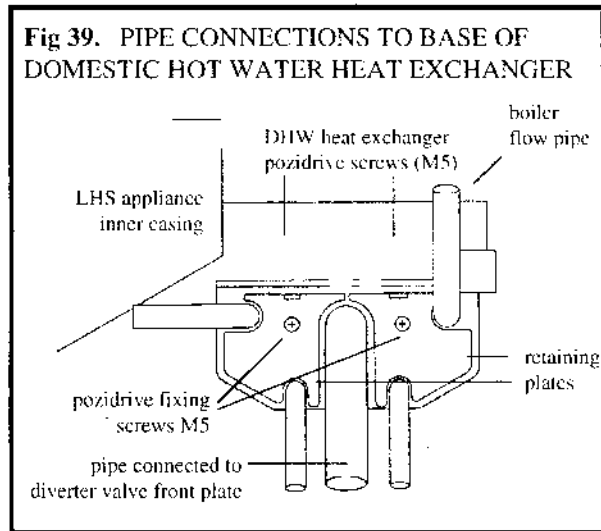
Refer Fig. 9.

Using an 8 mm spanner release completely the TWO M5 hexagon head fixing screws 'A'. Refer Fig. 38 and Fig. 40.

Unscrew the M5 pozidrive screw fixing the RIGHT HAND retaining plate to the base of the domestic hot water heat exchanger.

Refer Fig. 39.

Remove the plate, complete with screw.



Refer to Fig. 40 and note the FOUR M5 hexagon head fixing screws 'B' 'C' fixing the assembly to the main control support plate. Using an 8 mm spanner or screwdriver remove the two M5 hexagon head screws 'B', immediately underneath the front plate of the diverter valve. Pull the copper pipe forward, breaking the 'O' ring seals at the base of the domestic hot water heat exchanger and the front of the diverter valve.

Note:- The end of the pipe joining the mixing valve will come away complete with front plate, long fixing screws and steel clip.

Pull off the steel clip attached to the pipe and pass the end of the pipe through the hole in the front plate.

Refer to Fig. 40. Using an 8 mm spanner or screwdriver remove the TWO remaining M5 hexagon head screws 'C' retaining the pressure stat / diverter valve assembly to the controls support plate. The assembly can now be lifted clear of the appliance and replaced - reassembling in reverse order.

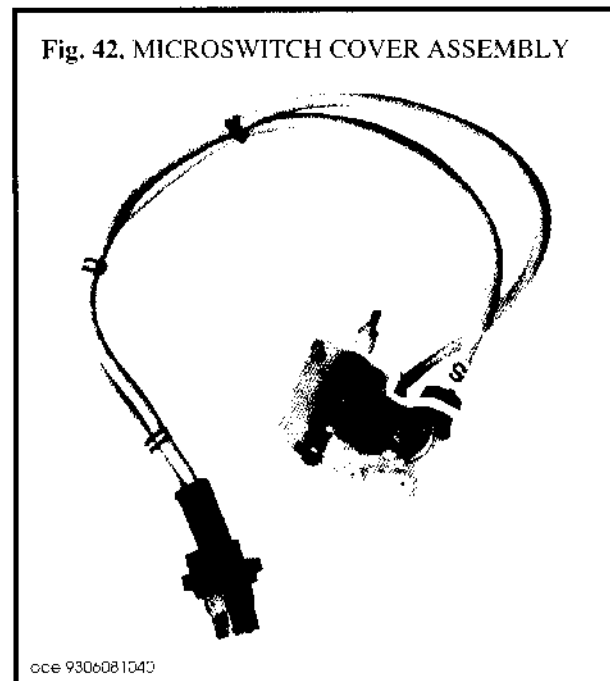
Note: When reassembling ensure all 'O' ring seals and washers are renewed. Fit the copper pipe to the front of the mixing valve before offering up the new assembly to the boiler for fixing. DO NOT OMIT the steel spring clip.

Before opening the isolation valves and refilling the system - REFER TO PAGE 8 - REQUIREMENTS FOR SEALED SYSTEMS - SECTION 7 and 8 and Fig. 3.

#### e) Replacement of Expansion Vessel

The expansion vessel is situated at the rear of the boiler. Under certain conditions of installation the boiler must be removed from the wall to allow access for removal of the vessel.

(i) If the appliance is either fitted with a rear flue outlet, or if there is a clearance of less than 350 mm (13 in) above the white casing



IT IS NOT POSSIBLE TO REMOVE THE VESSEL IN SITU - REFER TO (ii) OR (iii) BELOW.

(ii) If a side outlet flue is fitted and a clearance of at least 330 mm (13 in) is available above the white casing, proceed as follows:- Drain down the boiler in accordance with the procedure under Section 5.9.

Refer to Fig 43. Release the copper pipe union connection at the base of the expansion vessel using a 17 mm or adjustable spanner.

Unscrew the hexagon head nut holding the pressure vessel on the support bracket. Use either a 22 mm or adjustable spanner.

Lift the pressure vessel upwards and out of the boiler. Replace with a new vessel and connect it to the bracket and copper pipe union. DO NOT FORGET THE SHAKE-PROOF WASHER.

Before opening the isolation valves and filling the system - REFER TO REQUIREMENTS FOR SEALED SYSTEMS - SECTIONS 7 and 8 and Fig. 3.

(iii) If the vessel is faulty or if any leak can be isolated, then if

preferred the vessel can be isolated and a vessel of at least equivalent capacity can be fitted. This MUST be situated in the RETURN to the boiler as close as possible to the boiler. DO NOT FIT A VESSEL IN THE FLOW TO THE BOILER.

To remove the boiler from the wall, proceed as follows:-

After draining down the boiler in accordance with the procedure under Section 5.9 undertake the following.

Check that the electrical supply to the appliance is turned OFF at the isolation switch and that any clock or heating controls fitted are in the OFF position. Turn OFF the gas service cock. (Fig. 14) and Section 7.4.

Locate the black plastic cover over the terminal block into which the electrical supply to the appliance is wired. (Fig. 4).

The cover is positioned under the left hand side of the boiler inner casing.

Release the two pozidrive screws retaining the cover, remove it to expose the terminal block.

NOTE the position of any cables connected to the block. Disconnect them using an electrician's screwdriver.

Remove the TWO pozidrive screws retaining the cable clamp and withdraw the cables to the rear. Ensure the cables are free from the appliance when it is removed from the wall.

Check that draining down has been successfully undertaken and that all FOUR union connections on the BOILER SIDE of the isolation valves have been released.

Disconnect the drain pipe from the safety valve.

Refer to Fig. 36. Note the TWO M5 hexagon head screws fixing the gas service cock outlet flange to the gas valve.

Using an 8 mm spanner or a screwdriver remove the two screws and retain them for reassembly.

Refer to Fig. 10 and Fig. 17. Remove the PVC air pressure switch sensing line from the side of the flue turret by pulling it off the pressure point.

Examine the sensing line and check it is not twisted or damaged in any way. Replace if necessary. Unscrew the air duct locking ring. Using an 8 mm spanner or screwdriver remove the FOUR hexagon head screws positioned at each corner of the flue turret. Pull the turret away from the flue duct enough to expose the M5 pozidrive screw which retains the flue duct and restrictor ring in position. The screw is at the top centre of the duct.

Remove the screw. Remove the turret.

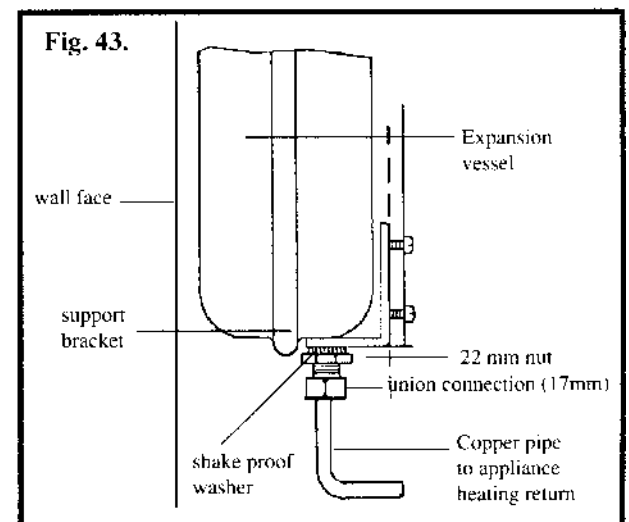
NOTE:- THE TWO SEALING GASKETS POSITIONED BETWEEN THE APPLIANCE TOP PANEL, THE FAN OUTLET AND THE TURRET MUST BE RENEWED ON REASSEMBLY.

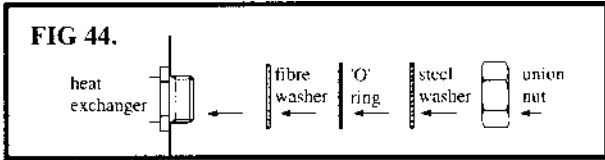
Lift the appliance about 10 mm and draw it forward to clear the supporting lugs at the rear left and right hand side of the jacket side panels. Support any long flue ducts at the back.

Lay the appliance face down on a suitable support such as two wooden battens. This will expose the expansion vessel at the rear of the boiler. Refer to Fig. 43 and note the method of supporting and fixing the expansion vessel.

Release the copper pipe union connection at the base of the expansion vessel using a 17 mm or adjustable spanner.

Unscrew the hexagon head nut holding the pressure vessel on the support bracket. Use either a 22 mm open ended or adjustable





spanner. Lift the pressure vessel upwards out of the boiler. Replace with a new vessel and connect it to the bracket and copper pipe union. **DO NOT FORGET THE SHAKE PROOF WASHER.** Lift the appliance back onto its wall plate ensuring the supporting lugs are properly engaged.

Using the reverse of the above procedures, remake all water, gas, flue and electrical connections.

**NOTE:-** Be sure to undertake gas and water soundness checks before attempting to light the appliance or operate the system.

Replace the gas cock 'O' ring seal and all sealing washers at the central heating and domestic hot water connections to the appliance. Refer to Sections 5 to 8 inclusive.

When replacing the flue turret prior to refitting the flue / air duct system it may be found easier when fitting the FOUR M5 hexagon head screws to remove the inner casing front panel in order to gain access to the fan.

Refer to Fig. 17 and Section 4.1.

Before opening the isolation valves and filling the system - REFER TO PAGE 8 - REQUIREMENTS FOR SEALED SYSTEMS - SECTIONS 7 AND 8 and Fig. 3.

**f) Replacement of safety valve**

Identify the safety valve (Fig. 9). The valve is positioned under the left hand side of the appliance behind the main controls support plate.

Disconnect the drain pipe from the safety valve. Use a 26 mm or adjustable spanner to remove the safety valve from the left hand side of the central heating flow isolation valve. Replace the valve using an approved jointing compound around the thread (APPROVED TO BS 5292:1980).

Refit the safety valve drain pipe.

Before opening the isolation valves and filling the system - REFER TO PAGE 8 - REQUIREMENTS FOR SEALED SYSTEMS - SECTIONS 7 AND 8 and Fig. 3.

**g) Replacement of stainless steel domestic hot water expansion vessel (if fitted)**

Switch off mains water supply. The vessel is positioned under the water flow switch above the pump.

Use a 24 mm or adjustable spanner at the brass hexagon socket, between the vessel and the isolation valve, to unscrew the pressure vessel.

Replace the vessel - AND SEALING WASHER.

Before opening the isolation valves and refilling the system - REFER TO PAGE 8 - REQUIREMENTS FOR SEALED SYSTEMS - SECTIONS 7 AND 8 and Fig. 3.

**h) Replacement of pressure gauge**

After draining down the boiler in accordance with the procedure under Section 5.9, identify the pressure gauge at the right hand end of the control panel. Fig. 14.

Remove the white outer casing by releasing the two retaining screws and pull forward at the top left and right hand sides.

Refer to Fig. 36. Using a 17 mm or adjustable spanner release the union connector at the point where the pressure gauge capillary joins the boiler return pipe.

Release the brass retaining nut behind the pressure gauge, remove the clamping bar and remove the gauge by passing the capillary out through the hole in the front panel. Replace the gauge using the reverse of the above procedure.

Ensure a new fibre sealing washer is fitted at the union connection.

**i) Replacement of boiler heat exchanger and/or combustion chamber insulation**

Refer to Fig. 17.

Remove the appliance inner casing front panel combustion chamber front panel and pilot burner assembly. Sections 4.1; 4.2; 4.3 (a) (b) (c) - page 25.

Remove the burner assembly. Refer to Section 4.4.

Remove the air pressure sensing tube from the turret.

Refer to Fig. 10 and Fig. 17.

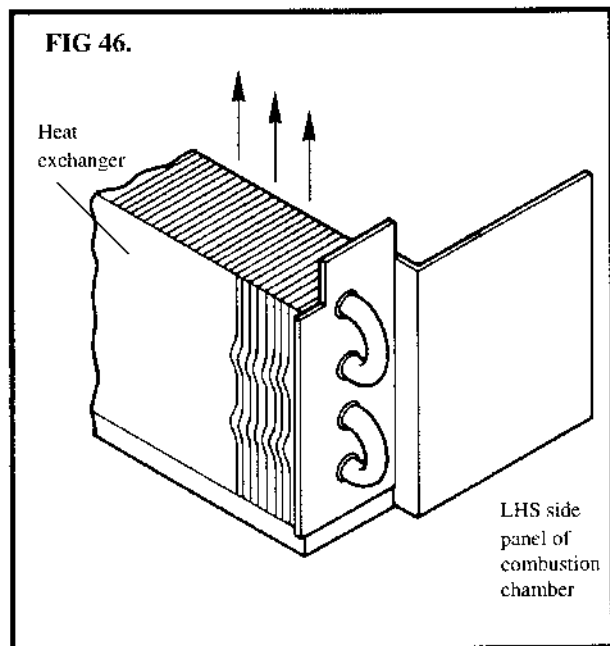
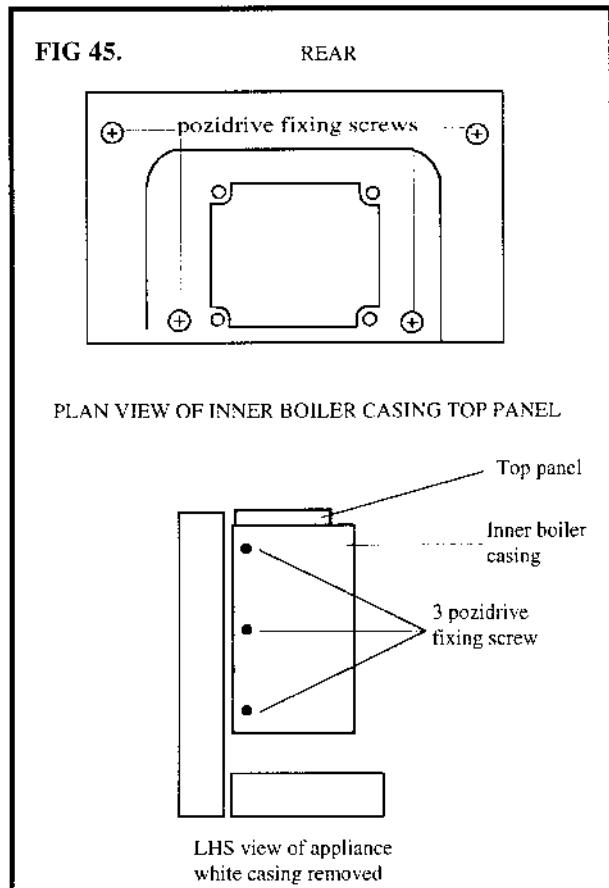
Unscrew the air duct locking ring.

Remove the fan. Refer to Section 4.7.

Remove the collector hood by lifting it up, clear of the top of the heat exchanger before drawing it forward out of the appliance.

Pull the turret away from the duct enough to expose the M5 pozidrive screw which retains the flue duct in position. The screw is at the top centre of the duct. Remove the screw. Remove the turret.

**NOTE:-** THE TWO SEALING GASKETS POSITIONED BETWEEN THE APPLIANCE TOP PANEL, THE FAN OUTLET AND THE TOP PANEL MUST BE RENEWED ON REASSEMBLY IF DAMAGED.



Unscrew the union connections at the heat exchanger flow and return pipe entry. (Fig. 28 and Fig. 29).  
 Remove the steel washer, 'O' ring and fiber washer from the heat exchanger stub connections (Fig. 44).  
 Remove the four pozidrive screws retaining the top panel of the inner room sealed chamber (Fig. 45).  
 Remove the top panel.  
 Remove HEYCO bush securing fan wiring through the rear panel.  
 Remove the fan wire from the room sealed chamber.  
 Release the two M5 x 10mm Bolts connecting burner injection supply pipe to the gas valve. The room sealed chamber can now be removed from the rear support frame by releasing the four pozidrive securing screws.  
 Lay the room sealed chamber on its back and remove the pozidrive screws securing the left and right hand side panels.  
 The heat exchanger can now be removed by grasping the front of the exchanger and, whilst supporting the combustion chamber, lift it up and away from the combustion chamber in the direction of the arrows (Fig. 46). **BE CAREFUL NOT TO PULL THE REAR INSULATION PAD (FIG. 36a) AWAY WITH THE HEAT EXCHANGER, OTHERWISE THE INSULATION MAY BE DAMAGED.**  
 Fit a new heat exchanger by sliding it down on to the top of the combustion chamber using the reverse procedure.  
 Replace the combustion chamber / heat exchanger assembly and reassemble the appliance in reverse order.

Ensure all inner boiler casing screws are fitted correctly. Renew the fibre washers and 'O' ring seals at the flow return union connections to the heat exchanger (Fig. 44).  
 Undertake water soundness checks.  
 Before opening the isolation valves and refilling the system - REFER TO PAGE 7 - REQUIREMENTS FOR SEALED SYSTEMS - SECTIONS 7 AND 8 and Fig. 3.

## 6 Flue terminal guard

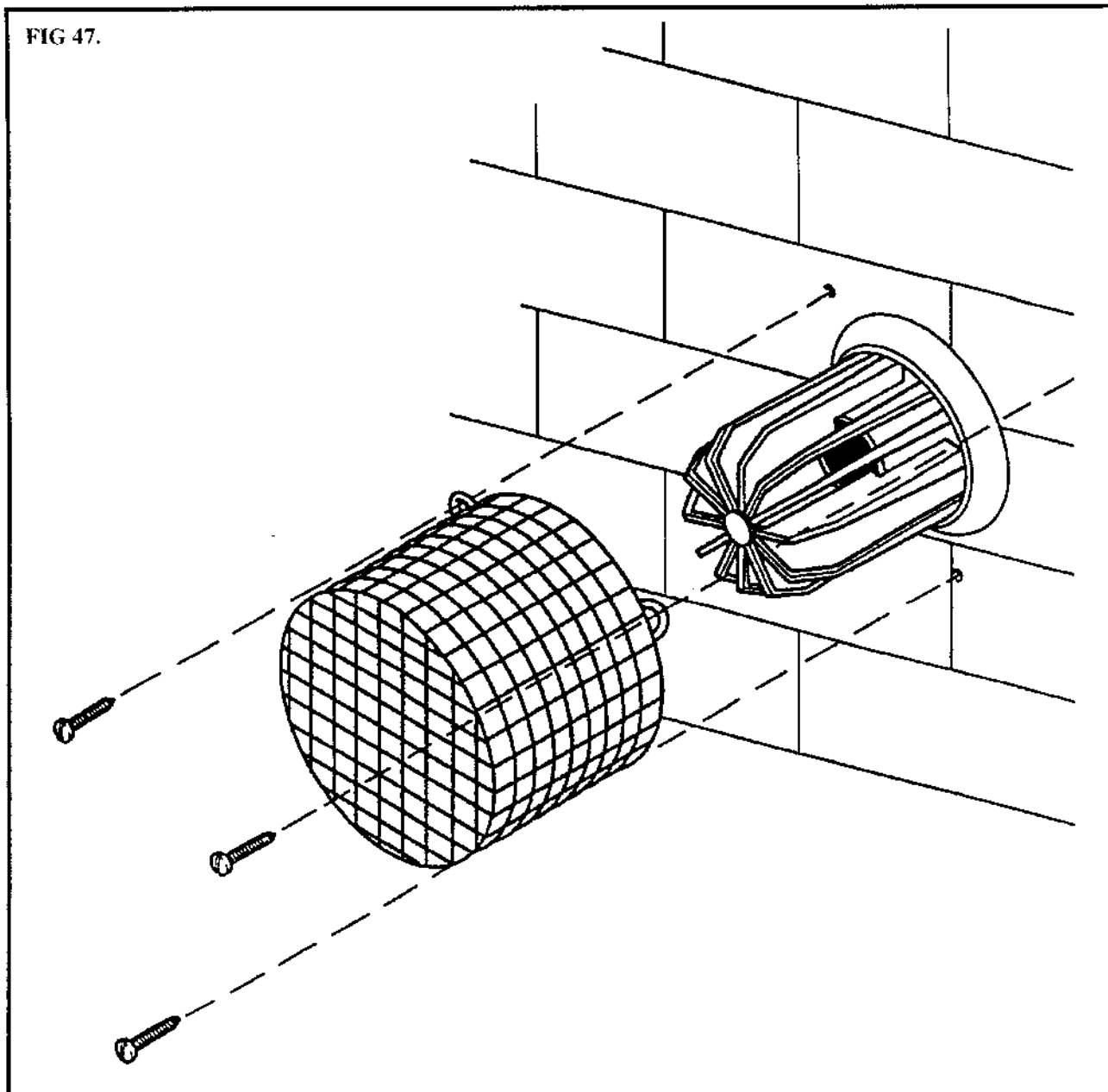
Refer to section 3.6 page 7

Terminal Guard reference number:- K3 (G.C. N° 393554)

Obtainable from:- Argos Building and Heating Supplies Ltd., United House, Goldsel Road, Swanley, Kent BR8 8EX.  
 Telephone:- Swanley (0322) 665522  
 or Tower Flue Components Ltd., Tower House, Vale Rise, Tonbridge, Kent. Telephone:- Tonbridge (0732) 351555

Fix the terminal guard to the outer wall face, concentrically about the terminal, using **THREE** N°8x32 mm (1 1/4 in) long brass wood screws (or similar weather resistant screws) and plugs. Do not fix to rendering or other external wall cladding liable to break away from the wall surface. Refer to Section 2 and Section 3.

FIG 47.



# SHORT PARTS LIST

Key No	GC N°	Description	No.	Ocean Part No.
1		Burner assembly comprising 15 removable burner blades, support frame and retaining rods. Type 80FF Manufacturer OCEAN Spa.	1	JJJ005615061
2-16		Removable burner blade. Type 80FF Manufacturer OCEAN Spa.	15	JJJ005604091
17-31		Burner injector. Size 1.18 mm. Type Natural gas, Manufacturer: Min-Tor Meccanica	15	JJJ005617041
32		Gas valve. Size 1/2", Type V4600Q2034, Manufacturer HONEYWELL. Note: item 81 also required	1	JJJ005615071
33		Pilot bracket.	1	JJJ005614791
34		Pilot injector. Type 0.140, Size 0.27 mm, Manufacturer SIT.	1	JJJ005201551
35		Electrode lead. Length 450 mm, Manufacturer: S.K.G.	1	JJJ008413451
36		Electrode - Spark. Type Target Manufacturer SIT.	1	JJJ008420931
37		Circulating pump. Manufacturer EURAMO. Type GOLD STAR. Note: item 38 also required	1	JJJ005617241
37A		Circulator - Grundfos UPS 15-60 Alternative to Key No: 37	1	JJJ005611791
38		Fibre washer kit for item 37	1	JJJ005615081
39		Combustion fan. Type RL97/4200 A26-3030LH76 Manufacturer ITT. Note: item 40 also required.	1	JJJ005607293
40		Cork sealing gasket SET FOR ITEM 39	1	JJJ005614701
*41		Control thermostat. Type KT 170 Manufacturer: METALFLEX. Length of capillary 800mm	1	JJJ005614811
42		Control thermostat knob.	1	JJJ005616401
*43		Safety thermostat. Type K36 L3258. Manufacturer: RANCO length of capillary 1200 mm.	1	JJJ005614821
43A		Safety thermostat. Imit Spa TR2/ST Alternative to Key No: 43	1	JJJ005618921
*44		Domestic hot water thermostat. Type K36 L3259 Manufacturer RANCO. Length of capillary 450 mm	1	JJJ005614831
44A		DHW Thermostat. Imit Spa TR2/DHW Alternative to Key No: 44	1	JJJ005618911
*45		Over heat thermostat and ECO lead. Type 36T21-12348. Manufacturer: THERMODISC.	1	JJJ005614841
45A		Over heat thermostat - Eith 261P Alternative to Key No: 45	1	JJJ005618901
46		Thermocouple. Type 0290136 Manufacturer SIT. Length of capillary 450 mm.	1	JJJ005614721
47		Connector for thermocouple	1	JJJ005202491
49		Suppressor - Radio: Type, F.AT.AG.2680 ZB 020. Manufacturer ARCOTRONICS alternative: Type, 411.13.2100. Manufacturer PROCOND	1	JJJ008450171
50		Synthetic rubber sealing gasket for pilot pipe, thermocouple and electrode lead.	1	JJJ005401652
52		Relay Type 60-73 Manufacturer. RELE' FINDER	1	JJJ008432951
53		Electrical resistor. Type SRH 25 B5-1K2 J Manufacturer: SECI ELETTRONICA	1	JJJ008432941
54		Spark Generator. Type 680 R15/05 Manufacturer. INECO	1	JJJ005607311
55		Fan air pressure switch. Type C6052A1007 Manufacturer: HONEYWELL	1	JJJ005609731
55A		Pressure switch. HONEYWELL C6065 A 1010 Alternative to Key No: 55	1	JJJ005617550
56-57		Ignition control microswitch. Type: N8 Manufacturer. ELBI	1	JJJ008432771
58		Water flow sensor switch. Type SFS 1 Manufacturer: MUT. MECCANICA Note: items 59 also required	1	JJJ005615371
59		Fibre washer kit for item 58	1	JJJ005615091
60		Domestic hot water heat exchanger. Type: UK Manufacturer: OCEAN SPA Note: also 61 item required	1	JJJ005610361
61		'O' ring kit for item 60	1	JJJ005614761
62		Microswitch cover assembly for water pressure stat complete with leads and plug. Manufacturer: OCEAN SPA Note: item 63 also required	1	JJJ005617081
63		'O' ring and fibre washer kit for item 62	1	JJJ005615101

\* These items supplied complete with sachet of heat sink paste.

Key No	GC. No	Description	No.	Ocean Part No.
64		Water pressure stat and diverter valve assembly. Type:80FF. Manufacturer: OCEAN SPA Note: item 65 also required	1	JJJ005617091
65		'O' ring and fibre washer kit for item 64	1	JJJ005614781
66		Service selector knob	1	JJJ005610981
67		Expansion vessel Manufacturer: ZILMET Capacity 7 litre. Items 79: 82 and 84 also required	1	JJJ005610141
68		Domestic hot water expansion vessel	1	JJJ005610151
68A		Domestic hot water expansion vessel optional kit	1	KIG714010110
70		Boiler heat exchanger. Manufacturer: GIANNONI Note: item 71 also required	1	JJJ005606432
70A		Heat exchanger.GIANNONI Alternative To Key No: 70 and 70B	1	JJJ009950120
70B		Heat exchanger.OCEAN/CM Alternative To Key Nos: 70A and 70B	1	JJJ009950120
71		'O' - rings and fibre washer kit for item 70.	1	JJJ005614771
72		Safety valve. Type: 1/2" Manufacturer ORKLI. Setting pressure 3 bar	1	JJJ005608551
73-77		Combustion chamber insulation panels. Type: 80FF Style	5	JJJ005614731
78		Fibre washer kit for water union connections on INLET side of wall template.	1	JJJ005617101
79		Fibre washer kit for water union connections on BOILER side of wall template.	1	JJJ005617101
80		Gas cock. Manufacturer: CIMBERIO	1	JJJ005614281
81		Gas valve 'O' ring seals at inlet and outlet of gas valve.	2	JJJ005615121
82		Large air duct 'O' ring seal	1	JJJ005401581
83		Fibre washer for water flow switch copper sensing pipe union connection to boiler return pipe.	1	JJJ005617211
84		Fibre washer for pressure gauge capillary union connection to boiler return pipe.	1	JJJ005402081
85		Pressure gauge. Manufacturer: T e G. Note: item 86 also required	1	JJJ008922201
86		Fibre washer for item 85	1	JJJ005402081
87		Pilot pipe complete with connectors	1	JJJ005614851
88		Domestic hot water filter and 'O' ring seals	1	JJJ005615131
89		Time clock (if used)	1	CS001X47
162		DHW Restrictor 10 litres	1	5822881

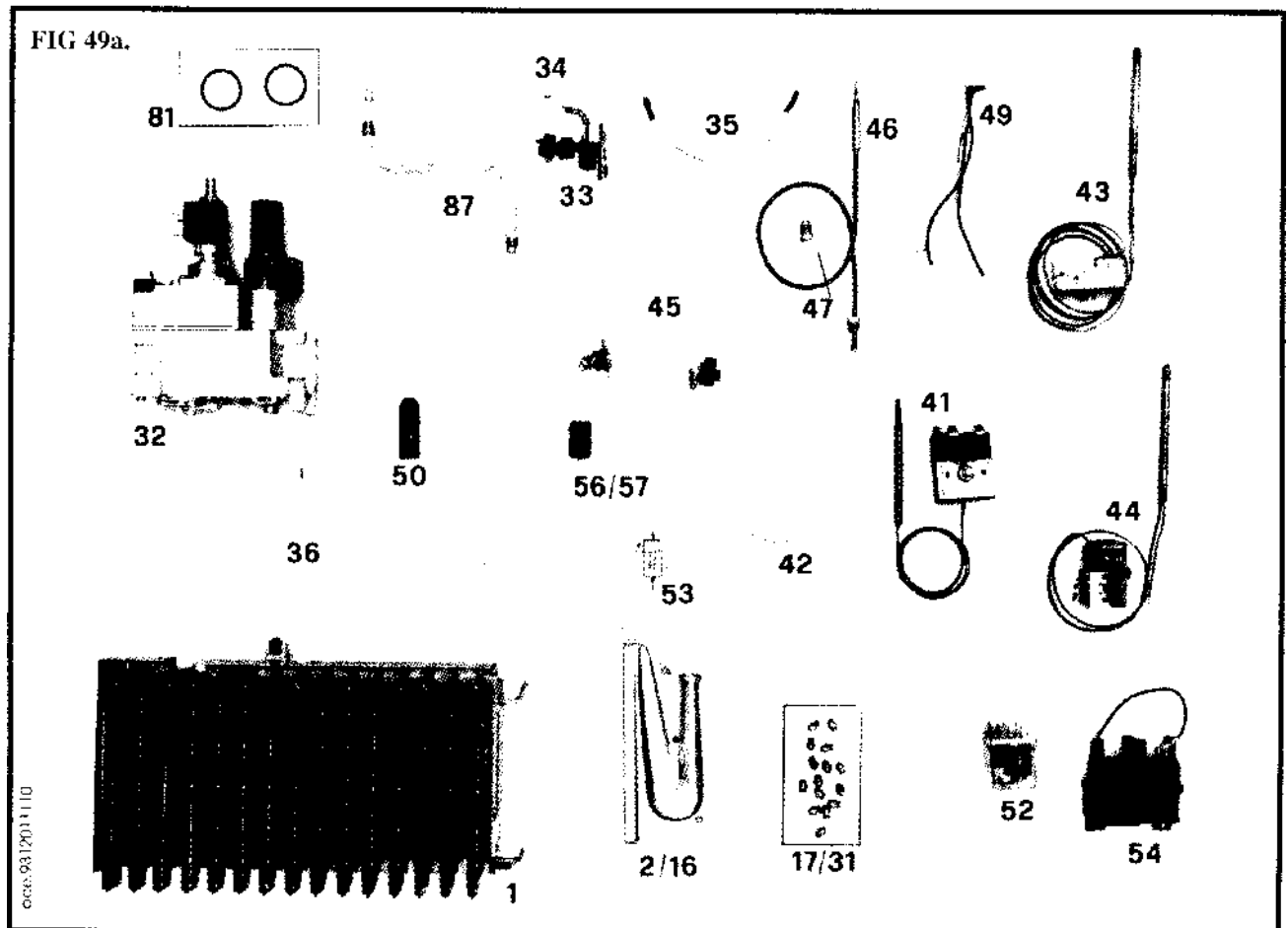
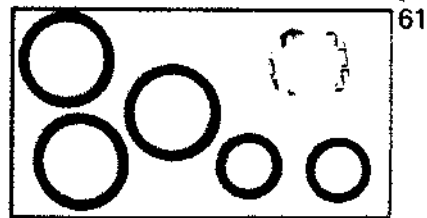
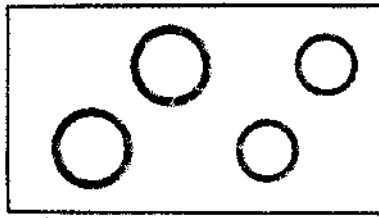
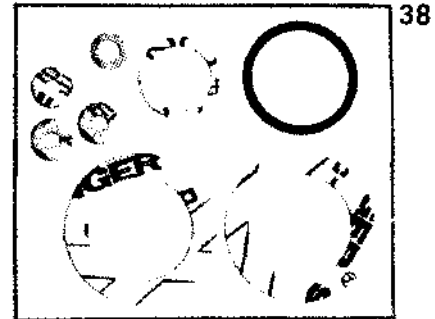
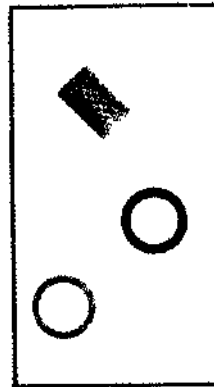
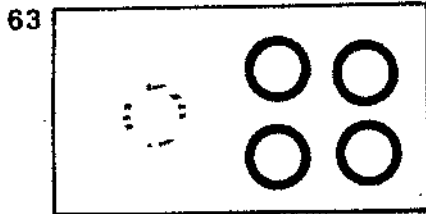
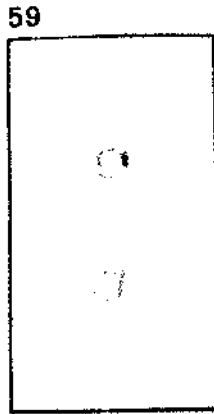
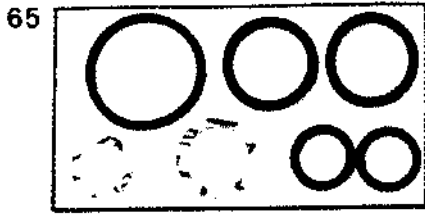
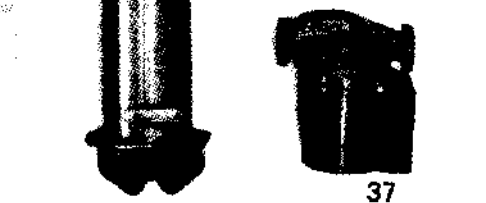
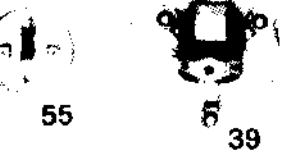
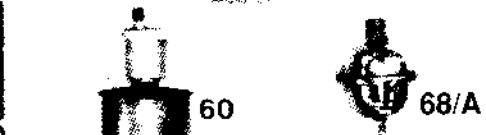
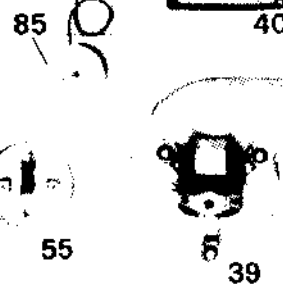
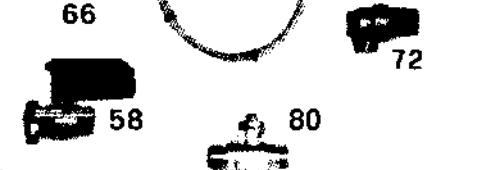
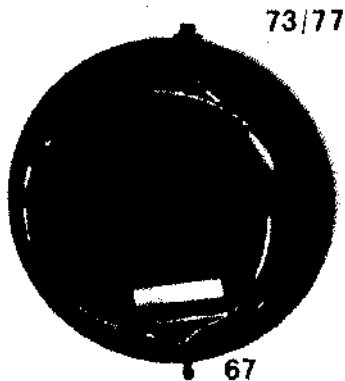
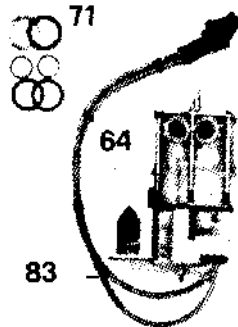


FIG 49b.



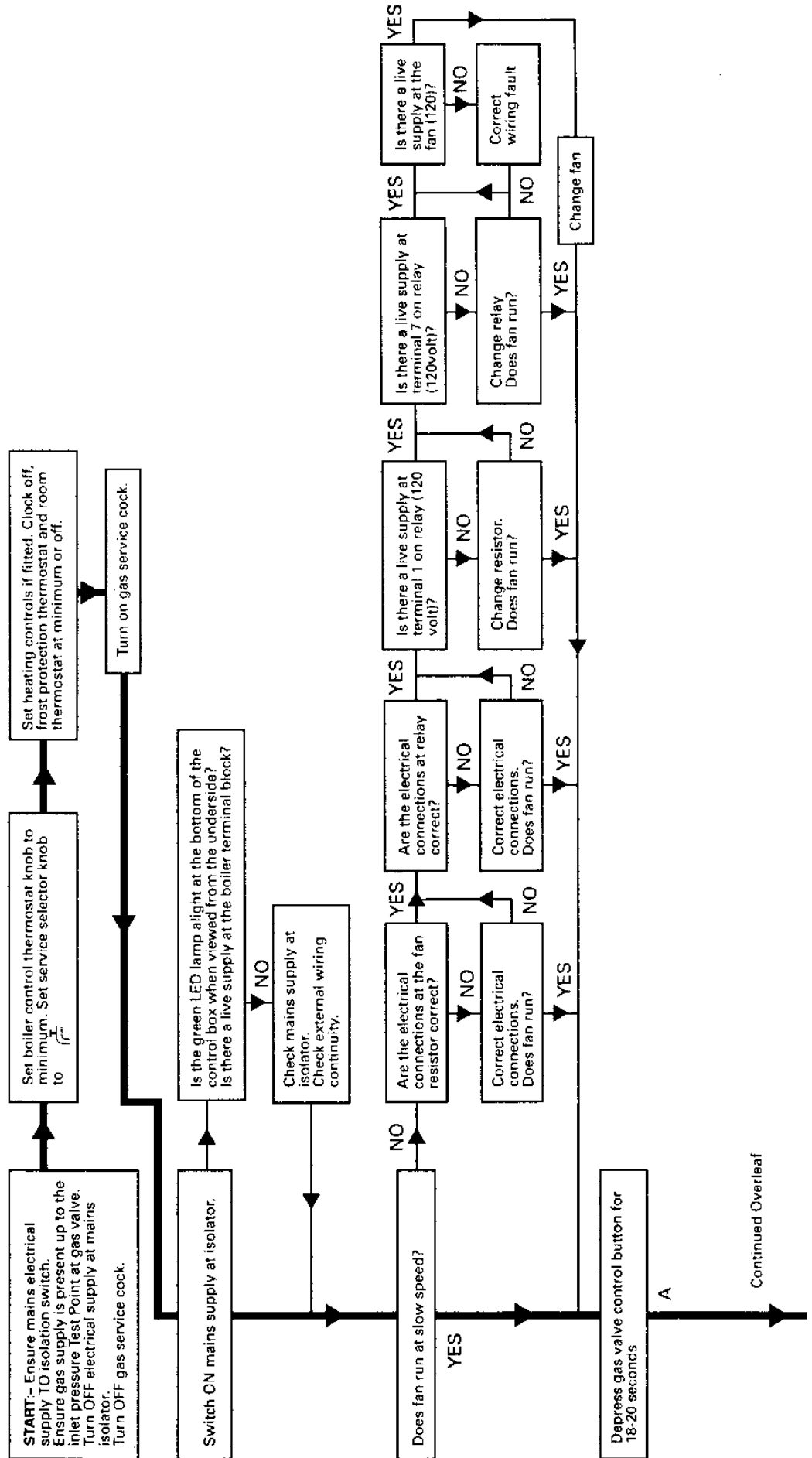
oce.9312011130

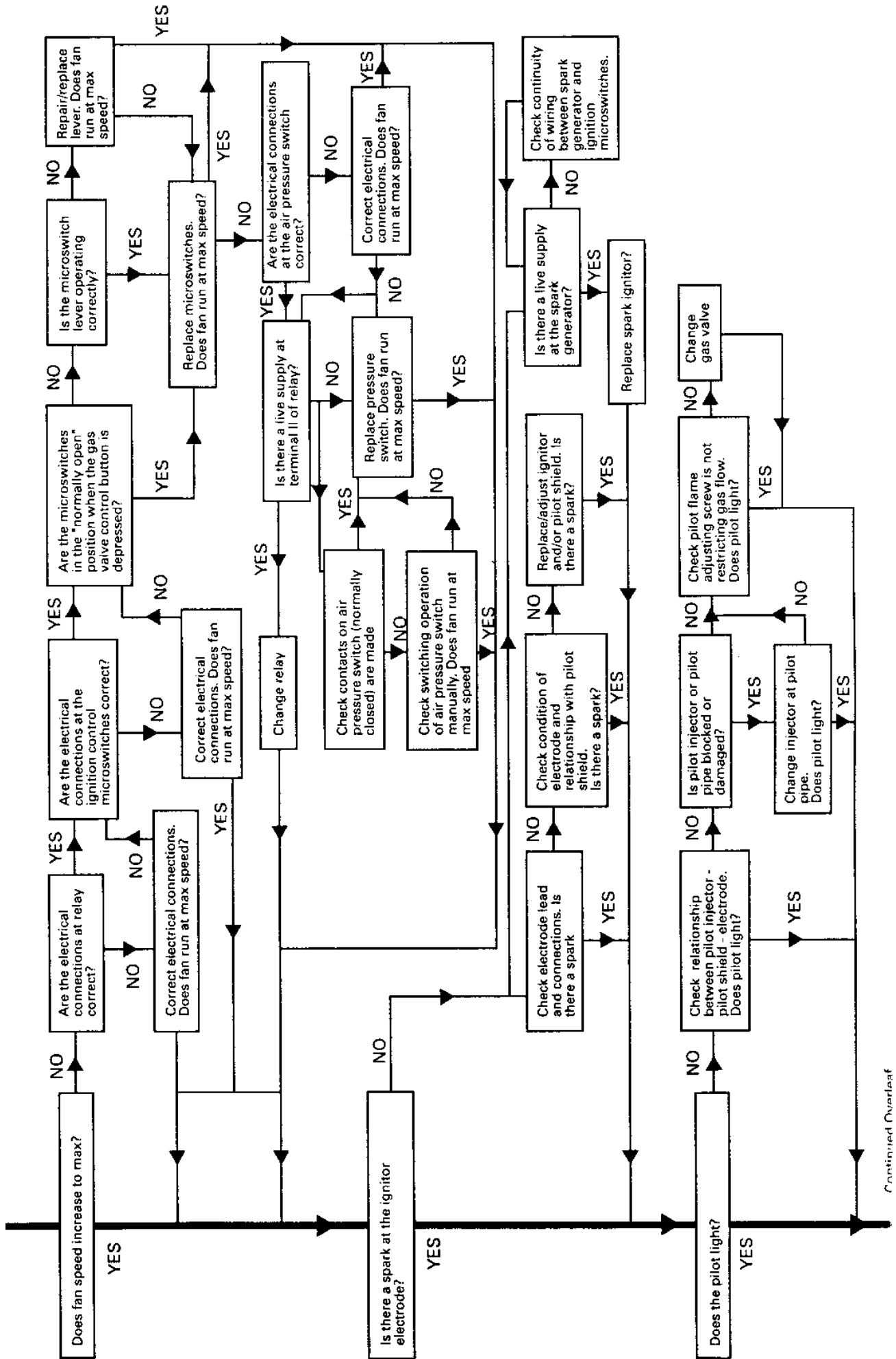


oce.9312011140

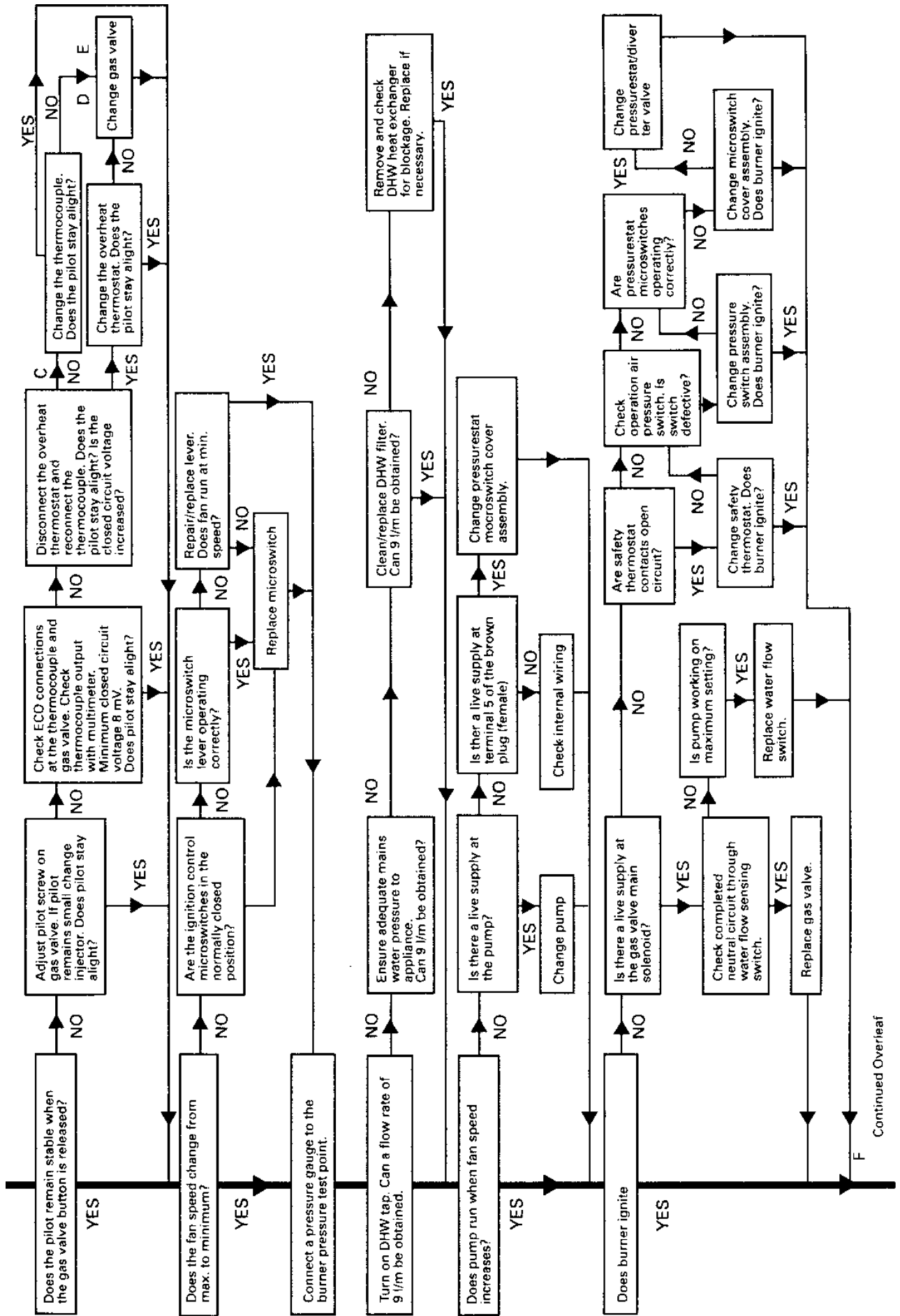
# FAULT FINDING

**IMPORTANT NOTE:** The FIRST electrical checks to be undertaken during a fault finding procedure are the preliminary electrical checks. ENSURE that whenever a Servicing or Fault Finding check has been undertaken which has required the breaking and remaking of electrical connections, the checks A: EARTH CONTINUITY; B: SHORT CIRCUIT; C: POLARITY; D: RESISTANCE TO EARTH - ARE REPEATED ALWAYS check wiring continuity between components before replacing them.

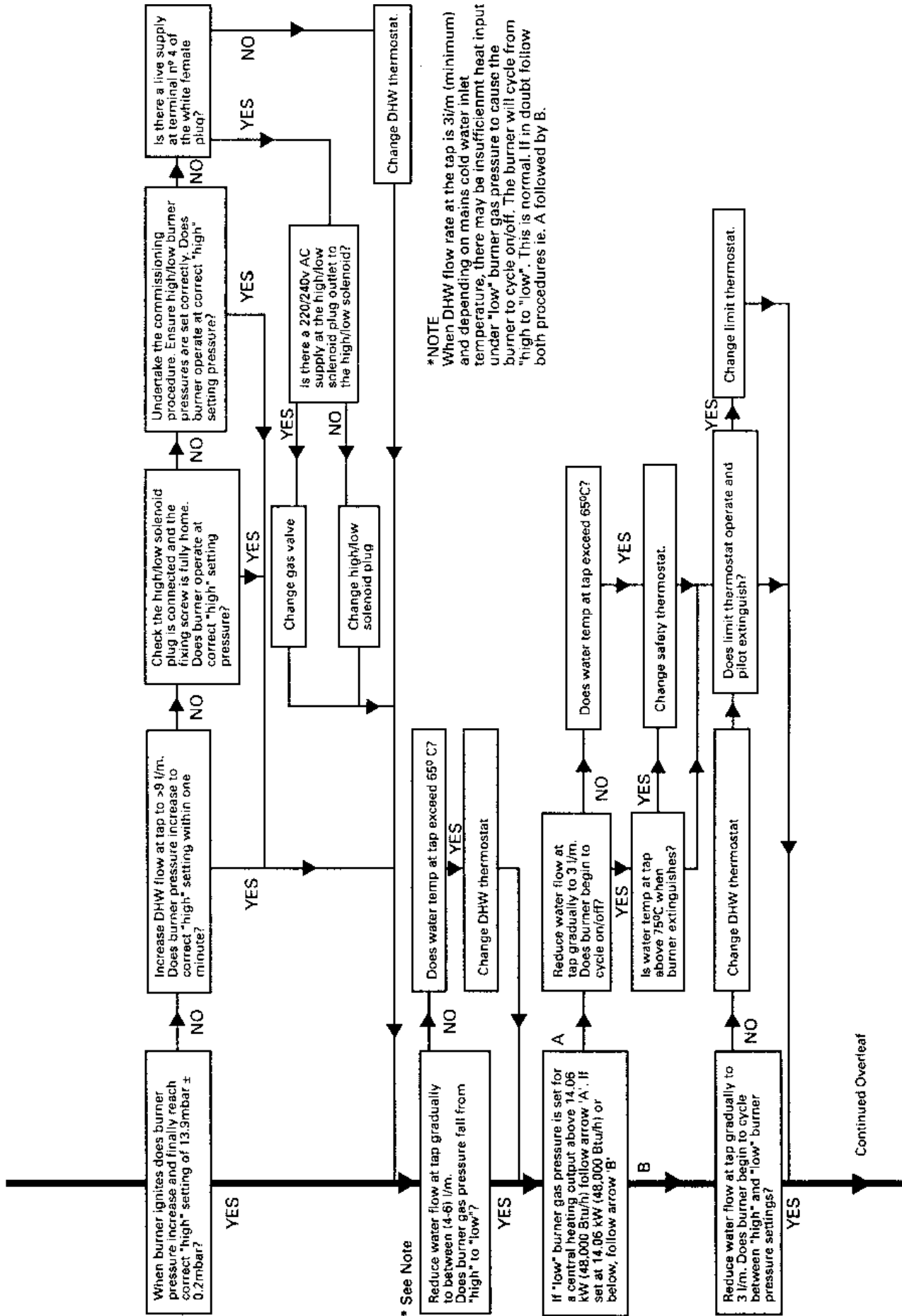


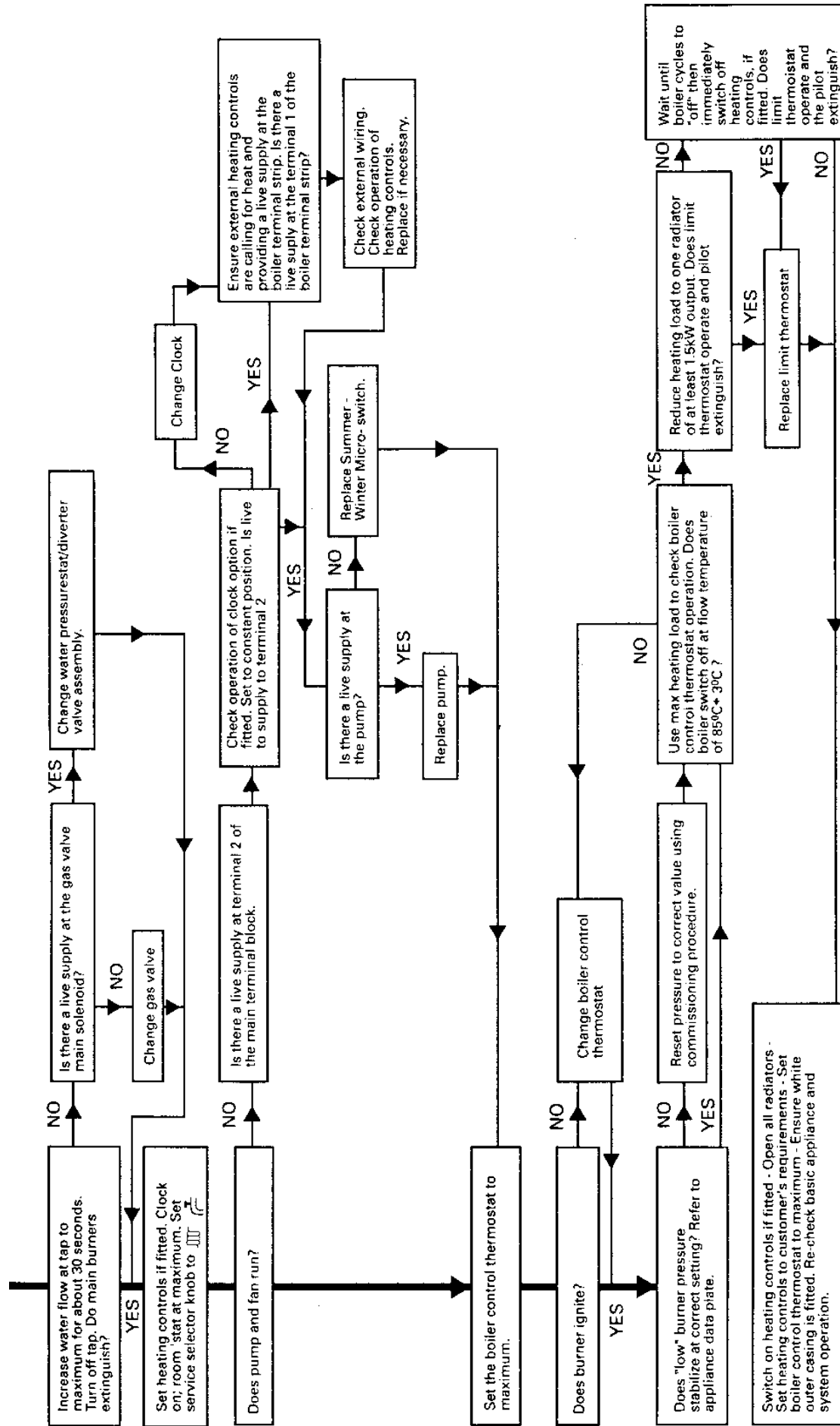


Continued Overleaf



Continued Overleaf







Alpha Therm Limited.  
Goldsel Road, Swanley, Kent BR8 8EX  
Tel: (01322) 669443  
Fax: (01322) 615017  
email: [info@alphatherm.co.uk](mailto:info@alphatherm.co.uk)  
website: [www.alpha-boilers.com](http://www.alpha-boilers.com)

# *Ocean Style* FF

**WALL MOUNTED, GAS FIRED COMBINATION  
BOILER FOR USE WITH NATURAL GAS ONLY**

## **OPERATING INSTRUCTIONS FOR THE USER**

Gas Safety (Installation and use) Regulations 1984:- It is the law that all gas appliances are installed by a competent person, in accordance with the above regulations. Failure to install appliances correctly could lead to prosecution. It is in your own interest, and that of safety, to ensure compliance with the law.

For Technical help or for Service call ...

**ALPHA HELPLINE**  
**Tel: (01322) 669443**

**Alpha**  
BOILERS

Goldsel Road,  
Swanley, Kent BR8 8EX  
Fax: (01322) 615017

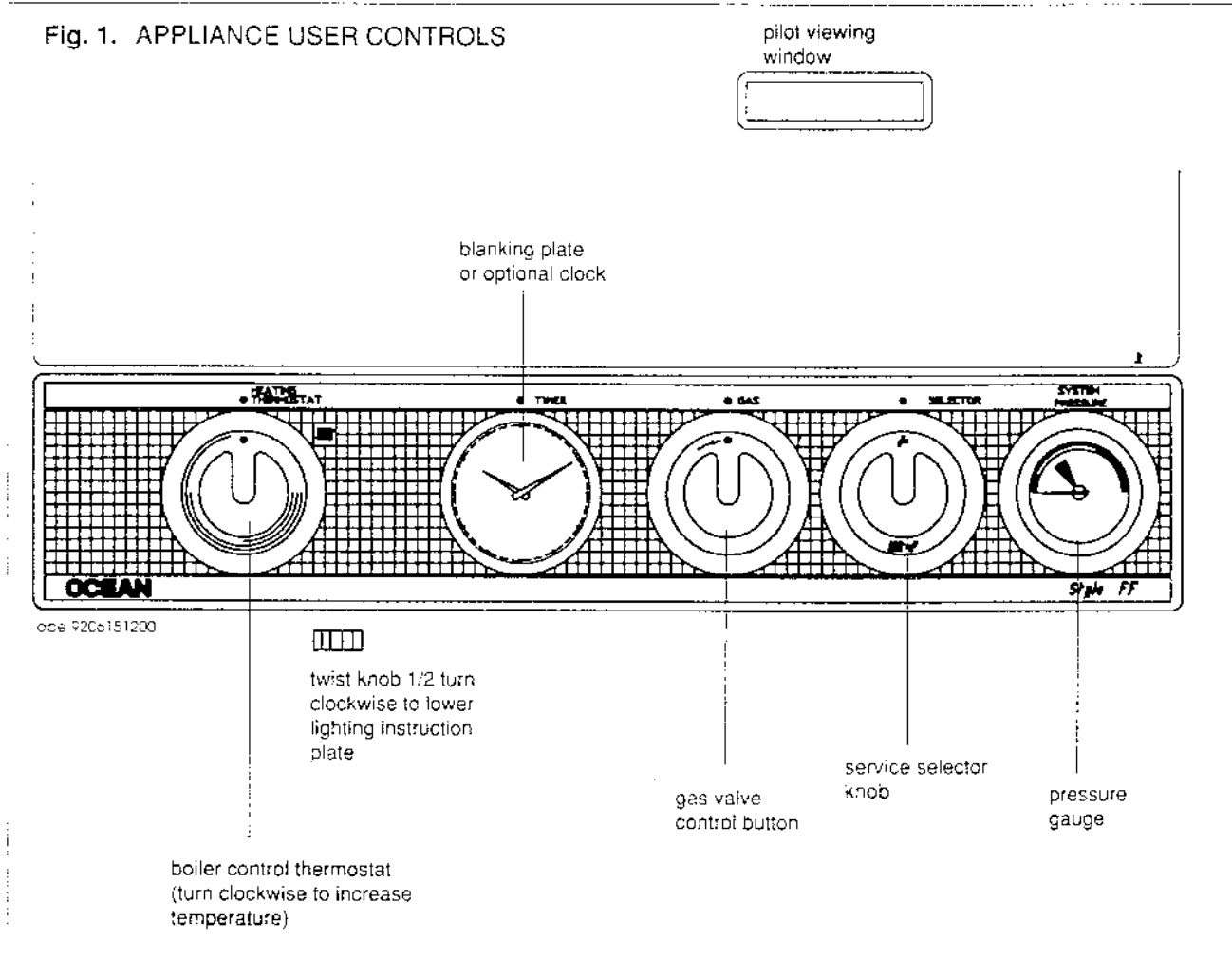
## 1. DESCRIPTION OF THE APPLIANCE

The Ocean Style FF is a wall mounted gas fired combination boiler. It provides a domestic hot water and central heating service. When the central heating service is not required the appliance can be set by the user to provide domestic hot water only up to a maximum output of 23.4 kW (80,000 Btu/h). Hot water is made available almost instantaneously at the boiler but the final temperature and the time taken for hot water to reach a tap will depend upon the rate at which water is drawn off and the length of the service pipe between the appliance and a tap.

NOTE:- ADJUSTMENTS - SERVICING AND THE REPLACE-

MENT OF COMPONENT PARTS MUST BE CARRIED OUT BY A COMPETENT PERSON IN ACCORDANCE WITH THE GAS SAFETY (installation and use) REGULATIONS 1984. Within the boiler, the services of central heating and domestic hot water operate independently; when there is a demand for domestic hot water this takes priority. The services are controlled from a knob on the boiler control panel which may be set to domestic hot water only (summer condition) or domestic hot water and central heating (winter condition). Refer to Fig. 1

Fig. 1. APPLIANCE USER CONTROLS



## 2. APPLIANCE METHOD OF OPERATION

When there is no demand for either domestic hot water or central heating the fan runs at low speed and the pilot remains alight permanently unless switched off by the user as described in section 6.

Any demand for domestic hot water will be sensed by detecting water flow through the boiler, provided the flow rate is above the minimum of 3 l/min (0.66 gpm).

The fan will increase to full speed and the boiler switch on at its full output.

If the rate of draw off is near the maximum design flow rate of 9.6 l/min (2.1 gpm) the boiler will run continuously at full output until a tap is either turned off or the rate at which water is being drawn off is reduced.

If the user selects domestic hot water and central heating and if all domestic taps are off and the heating clock and controls are calling for heat (refer below to section 3) the boiler will ignite to provide the preset central heating output.

A control thermostat is provided to allow the user to regulate the boiler central heating water flow temperature. Adjustment is by means of a knob on the boiler control panel (Fig. 1).

Adjustment of the control thermostat knob does not affect domestic hot water temperature. The thermostat controlling domestic hot water temperature is not accessible to, or adjustable by, the user.

At intermediate draw off rates around 5 to 7 l/min (1.1 to 1.5 gpm) the boiler will usually cycle between its maximum output and whatever output has been set by the installer or run continuously at its low output until either a tap is turned off or the rate at which water is being drawn off is reduced.

At minimum draw off rate 3 l/min (0.66 gpm) the boiler will settle down to cycle ON:OFF.

Under these conditions water temperature at a tap would normally be around 40-45 °C at maximum rate (9.6 l/min - 2.1 gpm) and 75-80 °C at minimum flow rate (3 l/min - 0.66 gpm) depending on particular circumstances.

### 3. HEATING CONTROLS

The boiler is not provided with a heating timer or controls, other than the boiler control thermostat, with which to control heat output from the radiators.

The Installation, Commissioning and Servicing Instructions provide the installer with full details of how a heating timer and/or heating controls should be fitted.

### 4. TO OPERATE THE APPLIANCE

Please ensure that the installer advises you on the correct operation of the appliance, system and any heating controls fitted.

1. Refer to Fig. 1. Switch off the mains electrical supply at the isolation switch or wall socket. Ensure any heating timer and/or heating controls, such as a room thermostat are in the OFF or MINIMUM position. Ensure all water isolation valves are in the open position ie. slots in line with pipes.

2. Operate the boiler ONLY if it and the system has been fully charged to correct design pressure. Observe the pressure gauge. When cold this would read normally between 0.5 and 1.5 bar. If in doubt consult the installer as to the correct pressure when cold.

3. Turn the boiler control thermostat fully counterclockwise to the MINIMUM position. Grasp the gas valve ignition button and turn it clockwise a quarter of a turn against the spring pressure and release. Set the service selector knob to domestic hot water.

4. Turn ON a domestic hot water tap and ensure water flows freely. Turn OFF the tap. At intermediate draw off rates around 5 to 7 l/m (1.1 to 1.5 gpm) the boiler will usually cycle between its maximum output and whatever output has been set by the installer or run continuously at its low output

5. Switch ON the mains electrical supply at the isolation switch or wall socket. Ensure any heating timer and / or heating controls are

ON or calling for heat and adjusted to the desired settings.

6. Depress fully the gas valve control button for 18-20 seconds. After a delay the ignition spark will commence and the pilot will ignite. When the button has been released the pilot should remain alight. Observe the pilot through the pilot viewing window. If the pilot does not remain alight, twist the gas valve control button in the direction of the arrow and release. If the pilot is extinguished at this, or any other time, wait at least 3 minutes before attempting to relight.

7. When the pilot remains alight, turn on a domestic hot water tap. The main burner should ignite. Turn OFF the tap. The burner should extinguish.

8. Set the service selector knob to hot water and central heating. Turn the boiler control thermostat clockwise to MAXIMUM. The burners should ignite.

If any heating timer is set to the OFF position or any room thermostat turned down to minimum (PROVIDED HEATING CONTROLS ARE FITTED) the burners should extinguish. The burners should re-ignite when the external controls are reset. Set the boiler control thermostat to the desired setting.

NOTE:- Whenever the service selector knob is in the hot water and heating position the hot water service takes priority. Hot water will not be provided unless the draw off rate is at least 3 l/m (0.67 gpm). A hot water draw off rate on excess of 9 l/min from a single tap, or the operation of a number of taps will result in a reduced hot water temperature. Refer to section 2.

### 5. DATA PLATE AND LIGHTING INSTRUCTION PLATE

A data plate is positioned under the border, fixed to the main controls support plate.

Information on how to operate the appliance is provided on a hinged lighting plate under the main controls support plate. Twist the knob (Fig. 1) a quarter turn clockwise to lower the panel.

### 6. TO TURN THE CENTRAL HEATING SERVICE OFF

1. To turn the heating service OFF set the service selector knob to hot water only. See Fig. 1. To turn on the central heating services ensure all domestic hot water taps are off and set the service selector knob to central heating and hot water.

2. TO TURN OFF THE APPLIANCE FOR SHORT PERIODS. Set the service selector knob to hot water only. Ensure all domestic hot water taps are OFF.

3. TO TURN OFF THE APPLIANCE FOR LONG PERIODS. Turn the gas valve ignition button in the direction of the arrow and release: the pilot should go out. Isolate the electrical supply to the system and boiler by turning OFF the power supply at the wall socket or isolation switch. When relighting follow the full operating procedure in Section 4. Consult the installer as to the need for protection against frost by means of a frost thermostat or night set back room thermostat.

### 7. SERVICING THE APPLIANCE

If the appliance is to maintain its efficiency and continue to operate with maximum safety, over a period of many years, routine annual servicing is essential.

For advice on servicing contact either the sole UK Agents, Argos Building and Heating Supplies Ltd or the local Gas Region.

### 8. GENERAL INFORMATION

1. Should a fault occur with the boiler control system, the appliance is fitted with an overheat thermostat which will shut down the supply of gas to the burners - including the pilot - independent of the normal control system.

If this fault occurs when the main burner is firing or if the pilot flame continually requires relighting after following the procedure under Section 4 contact whosoever is routinely servicing the appliance. 2. In the event of the failure of the electrical supply to the appliance the pilot should remain alight.

Note: Depending on the conditions prevailing when power is interrupted it may be necessary to reset the gas controls and relight the pilot when power is restored. (Section A).

Normally the boiler will reignite automatically when power is restored if any heating timer or heating controls fitted are ON and calling for heat. Remember to reset any heating timer fitted whenever there has been either a power supply failure or the electrical supply to the appliance has been interrupted at the isolation switch or wall socket.

3. If the mains water supply fails or is turned off for any reason there can be no hot water service from the appliance until the supply is restored. The boiler may be operated to provide a central heating service. If supply pressure varies or is low - minimum 0.5 bar. (7.3 psi) - it may not be possible to turn on all hot water taps simultaneously and achieve a reasonable flow rate.
4. If the temporary hardness of the water supply to the appliance is in excess of 150 parts per million the fitting of an "in line" scale inhibitor is recommended. The local Water Undertaking will usually provide information and give advice in these matters.
5. The appliance functions as a fan assisted, balanced flue unit. Under no circumstances should the flue discharge terminal be obstructed. If damaged turn off the appliance and contact the installer / Gas Region.
6. Minimum clearances around the appliance must be maintained if the appliance is to operate safely and routine servicing is to be undertaken.

7. If the appliance has been installed within a cupboard or compartment high and low level ventilators will have been provided by the installer in accordance with the Installation, Commissioning and Servicing booklet included with the appliance. The ventilators MUST BE KEPT FREE FROM OBSTRUCTION AT ALL TIMES. The cupboard or compartment containing the boiler MUST NOT BE USED FOR THE STORAGE OF OTHER ARTICLES.

8. Ancillary equipment for use with the appliance such as mixing valves, showers, bidets etc. MUST be designed to operate at mains water pressure. General advice is given to the installer, relating to the installation and use of the above equipment, in the appliance Installation, Commissioning and Servicing Instructions. However, the local Water Undertaking should be contacted for specific information and requirements before fitting.

9. Use only a damp cloth and mild detergent to clean the appliance outer casing. DO NOT use abrasive cleaners.


POSITION	MINIMUM CLEARANCE REQUIRED
Above	270 mm (10.6 in)
Below	270 mm (10.6 in)
L.H. side	30 mm (1.2 in)
R.H. side	30 mm (1.2 in)
In front	450 mm (18 in)

## 9. ELECTRICAL SUPPLY

If a mains plug connection is used, it MUST be a 3-pin type, wired as shown in Fig. 3, and fused at 3 Amp.

**The appliance MUST be efficiently earthed.**

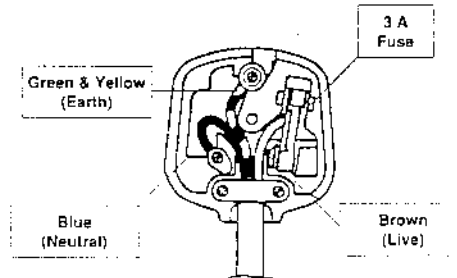
As the colour of the wires in the mains lead of this appliance may not correspond with the coloured markings identifying the terminals in your plug, proceed as follows:-

The wire which is coloured GREEN and YELLOW must be connected to the terminal in the plug with the letter E or by the earth symbol  or coloured GREEN or GREEN and YELLOW.

The wire which is coloured BLUE must be connected to the terminal which is marked with the letter N or coloured BLACK.

The wire which is coloured BROWN must be connected to the terminal which is marked with the letter L or coloured RED.

FIG 3. THREE-PIN PLUG (TO BS.1363)



Supply: 240 V, 50 Hz fused at 3 amps

### WARNING

**IF A GAS LEAK IS SUSPECTED OR EXISTS TURN OFF THE GAS SUPPLY TO THE APPLIANCE AT THE GAS SERVICE COCK. DO NOT TOUCH ANY ELECTRICAL SWITCHES TO TURN THEM EITHER ON OR OFF. DO NOT OPERATE ANY ELECTRICAL APPLIANCE. OPEN ALL WINDOWS AND DOORS. DO NOT SMOKE. EXTINGUISH ALL NAKED LIGHTS. CONTACT THE LOCAL GAS REGION IMMEDIATELY.**

## 10. HEATING CLOCK INSTRUCTIONS (IF FITTED)

### 1. SET TIME

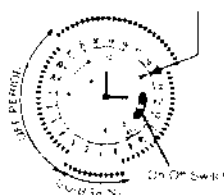
Turn outer dial to set clock hands to correct time. (Ensure arrow head corresponds with correct time on 24hr dial e.g. 3.00pm = 15 not 3)

### 2. SET ON/OFF PERIODS

Select ON time by pushing tappet OUTWARD

Select OFF time by pushing tappet INWARD

Sketch shows	ON	3.00pm	to 10.00pm (15-22)
{	OFF	10.00pm	to 5.00am (22-5)
	ON	5.00am	to 8.00am (5-8)
	OFF	8.00am	to 3.00pm (8-15)

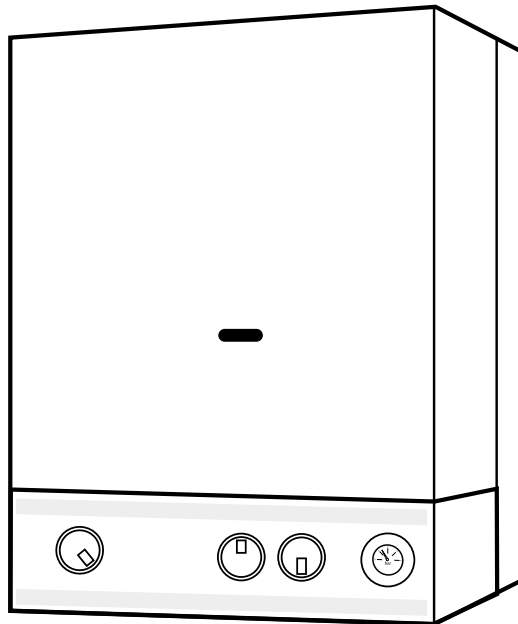


OCB 92061513X

### 3. MANUAL SWITCH

The clock has a manual ON/OFF switch which operates as follows:

Mid position	Heating ON/OFF as set by tappets
Up position (I)	Heating ON continuously
Down position (O)	Heating OFF continuously



# ***SPARE PARTS LIST***

**For**  
**Ocean Style 80 FF and Style 80 OF**  
**gas fired Combination boilers**

British Gas GC Number:-

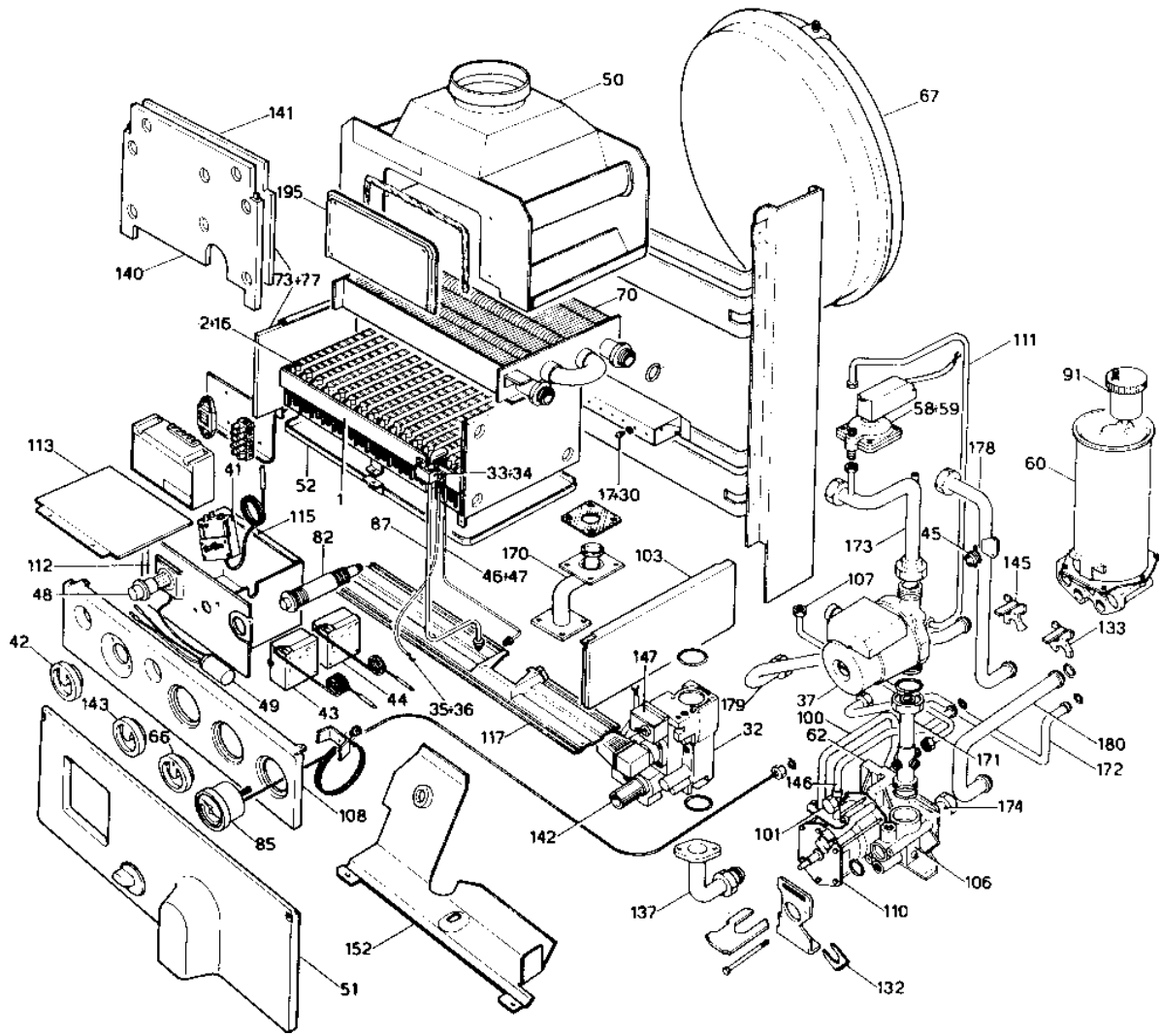
Ocean Style 80 FF 47 532 02

Ocean Style 80 OF 47 532 03

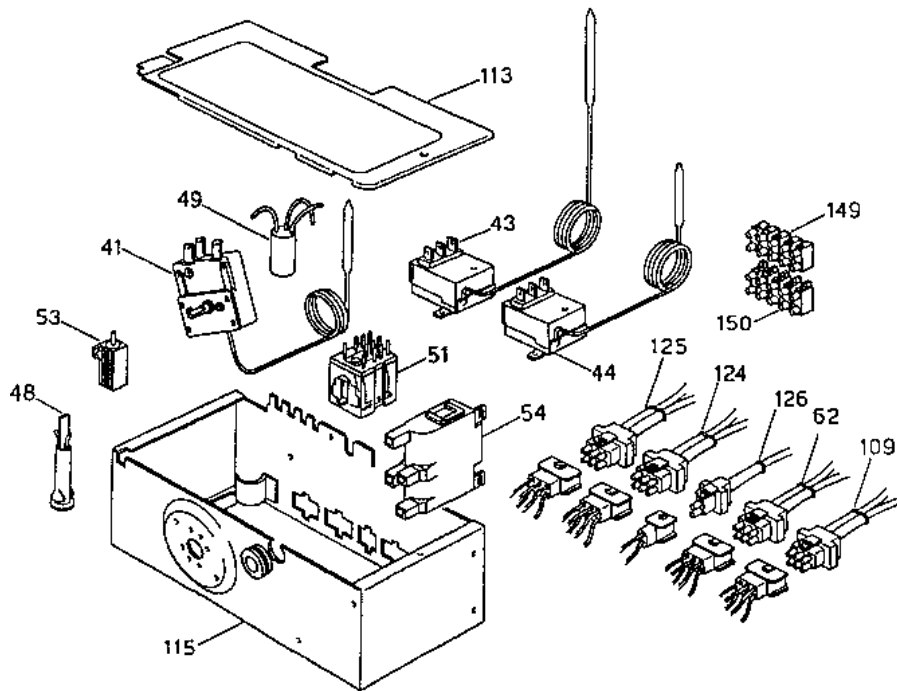
August 2002



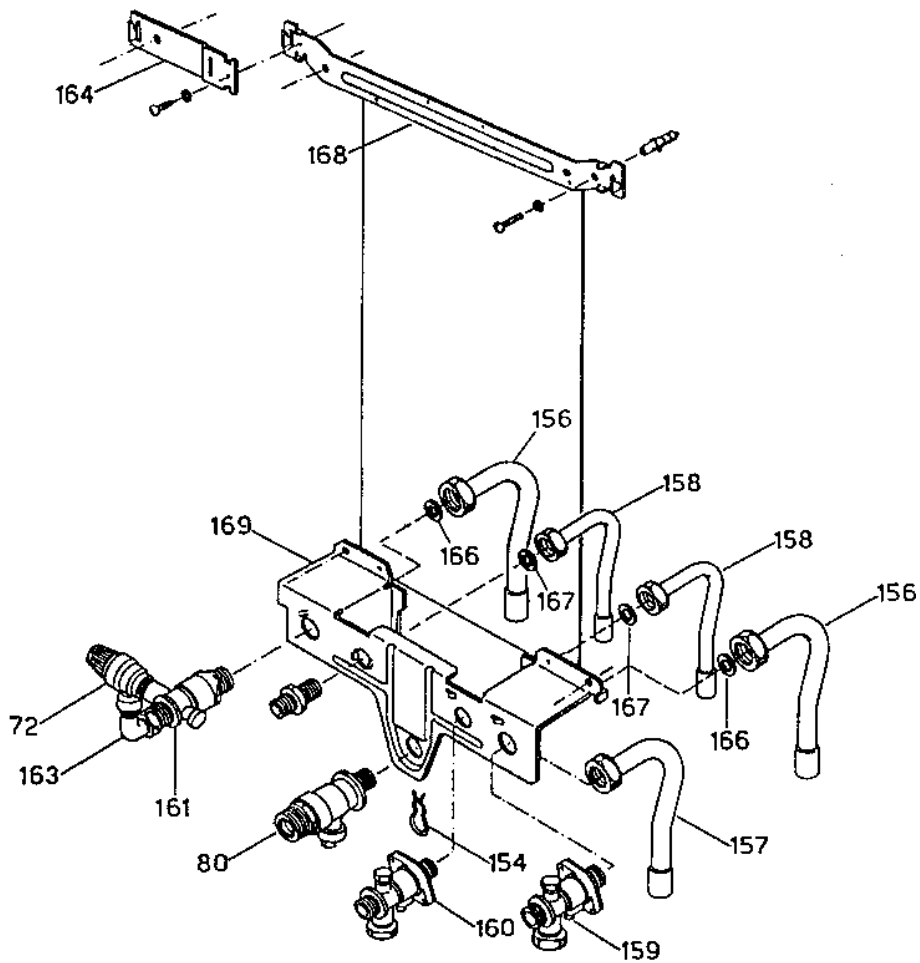
# Style 80 OF - Boiler exploded view



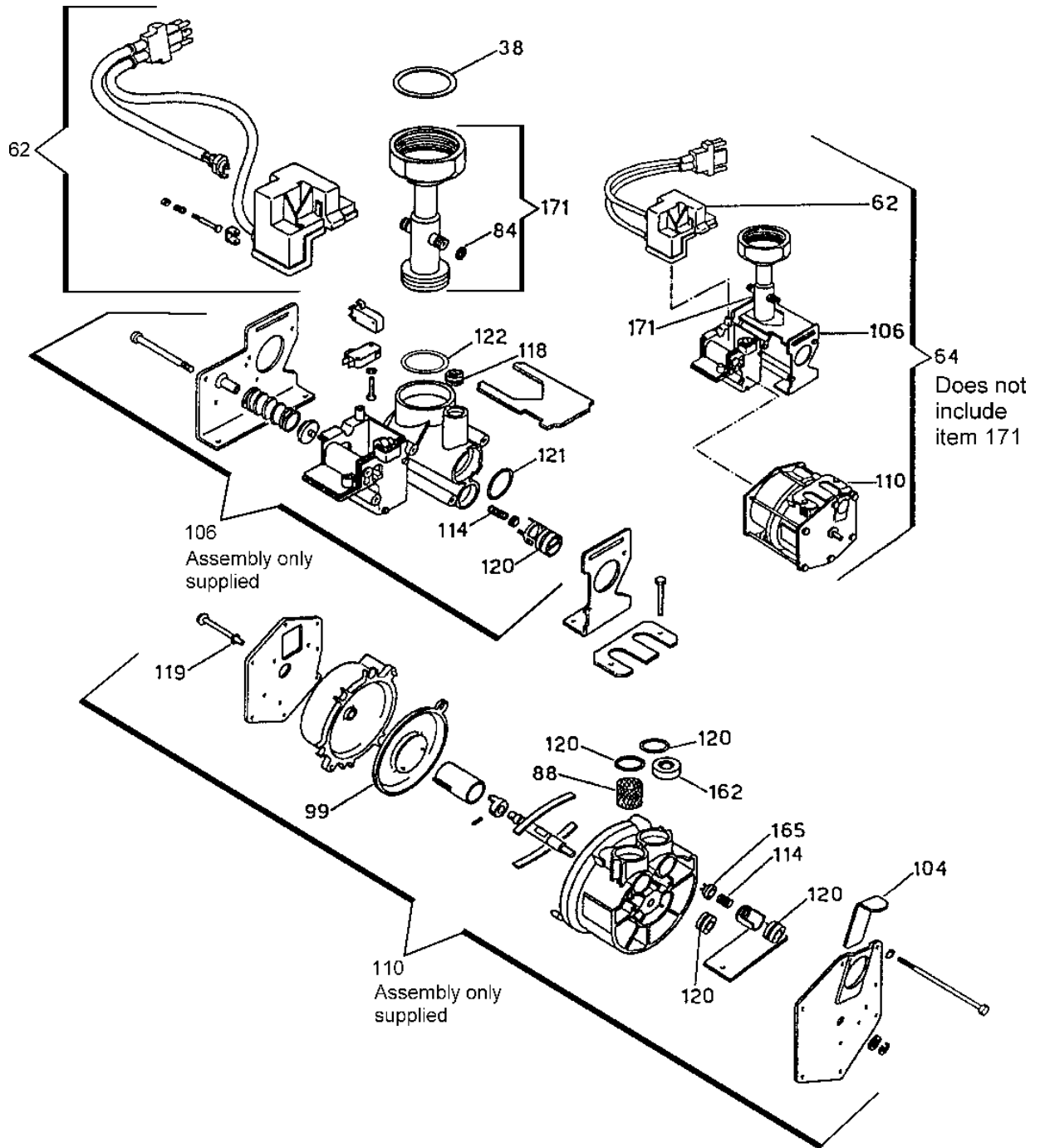
## Style - Control box



## Connection pipework



# 3-way valve



Ref No.	Ocean Style 80 FF	Ocean Style 80 OF	Description
1	6.5615061	6.5615061	Burner assembly
17-31	6.5209150	6.5209150	Main burner injector 1.18 mm (NG)
-	6.5605791	6.5605791	Injector manifold with injectors (NG)
32	6.5615071	6.5615071	Gas valve (NG) with control knob
32	6.5618891	-	Gas valve (LPG) with control knob
33	6.5604732	6.5604732	Pilot burner c/w injector 0.27 mm (NG)
34	6.5201550	6.5201550	Pilot injector 0.27 mm (NG)
35	6.8413451	6.8413451	Electrode lead
36	6.8420930	6.8420930	Electrode
37	6.5611791	6.5611791	Pump
38	6.1000710	6.1000710	Washer - pump connections (part of seal kit)
39	6.5607294	-	Fan
40	6.1000730	-	External flue turret gasket (part of seal kit)
40	6.1000730	-	Internal flue turret gasket (part of seal kit)
41	6.8432322	6.8432322	Heating thermostat
42	6.5616401	6.5616401	Heating thermostat knob
43	6.8433431	6.8433431	Safety limit thermostat
44	6.8433421	6.8433421	Hot water thermostat
45	6.5614712	6.5614712	Overheat thermostat with leads
46	6.5614721	6.5614721	Thermocouple
47	6.5202491	6.5202491	Thermocouple connector
48	6.8421751	-	Green LED indicator
48	-	6.8432991	On/Off switch
49	6.8450191	6.8450191	Capacitor
50	6.5401652	-	Pilot tube sealing gasket
50	-	6.5624600	Draught diverter
51	6.5632710	-	Relay
51	-	6.5618061	Lower plastic panel
52	-	6.5618601	Aluminium drip tray
53	6.8432941	-	Fan speed resistor
54	6.5607310	-	Spark ignition generator
55	6.5617551	-	Air pressure switch
56-57	6.5614801	-	Ignition microswitch with lead and plug
58	6.5635010	6.5635010	Water flow switch
60	6.5610362	6.5610362	DHW heat exchanger
62	6.5617081	6.5617081	Microswitch assembly (3-way valve)
64	6.5623431	6.5623431	3-way valve complete
66	6.5618331	6.5618331	Summer/winter knob
67	6.5606221	6.5606221	Expansion vessel
68	6.5624241	6.5624241	DHW shock arrester
70	6.5617451	6.5617441	Main heat exchanger
72	6.5608551	6.5608551	3 bar pressure relief valve
73-77	6.5614731	6.5614731	Combustion chamber insulation panel set
80	6.5614281	6.5614281	Gas service cock
81	6.1000725	6.1000725	'O' ring seal 28.24 x 2.62 (part of seal kit)
82	6.1000730	-	'O' ring seal 92 x 3 (part of seal kit)
82	-	6.8433221	Spark generator
84	6.1000715	6.1000715	Pressure gauge washer (part of seal kit)
85	6.8922330	6.8922330	Pressure gauge
87	6.5614851	6.5614851	Pilot supply tube
88	6.5102271	6.5102271	Water filter - 3-way valve

Ref No.	Ocean Style 80 FF	Ocean Style 80 OF	Description
91	6.5600731	6.5600731	Automatic air vent
92	6.5607482	-	Sealed chamber front panel
93	6.5103360	-	Pilot glass retaining plate
94	6.5203930	-	Pilot glass
95	6.5401610	-	Pilot glass gasket
97	6.5619031	-	Rear support frame
98	6.5105741	-	Outer case securing bracket
99	6.1000710	6.1000710	Main diaphragm (part of seal kit)
100	6.5610941	6.5610941	Mains water inlet pipe
101	6.5201351	6.5201351	Brass cap - 1/2" BSP
102	6.5613911	-	Sealed chamber top panel
103	6.5615352	6.5615352	Control box right hand side panel
103	6.5615362	6.5615362	Control box left hand side panel
105	6.5202271	-	Air pressure switch tube
106	6.5630531	6.5630531	3-way valve body only
107	6.5607391	6.5607391	Expansion vessel connection pipe
108	6.5622132	-	Control panel (clock option)
108	-	6.5621161	Control panel
110	6.5623410	6.5623410	DHW priority pressure sensor
111	6.5610161	6.5610161	Flow switch connection pipe
112	6.5622332	-	Electric control box (complete)
116	6.8100872	-	Sealed chamber front fixing screw
117	6.5610663	6.5610663	Gas valve support cross member
118	6.1000710	6.1000710	'O' ring restrictor by-pass (part of seal kit)
119	6.1000710	6.1000710	'O' ring cover sensor pivot - 3-way valve (part of seal kit)
120	6.1000710	6.1000710	'O' ring 13.94 x 2.62 - 3-way valve (part of seal kit)
121	6.1000710	6.1000710	'O' ring 22 x 3 - 3-way valve (part of seal kit)
122	6.1000710	6.1000710	'O' ring 3-way valve pipe (part of seal kit)
123	6.5639230	-	Flue venturi
-	6.5402050	-	Flue venturi gasket
-	6.5206212	-	Flue venturi hose adapter
124	6.8414941	-	Cable - Gas valve and water flow sensor
125	6.8415141	-	Cable - Fan/air pressure switch
126	6.8412882	-	Cable - Pump
127	6.8100611	6.8100611	Screw - Heating thermostat
129	6.8101181	6.8101181	Screw M5 x 10
130	6.8142431	-	Screw - Fan mounting plate
131	6.8100572	-	Screw
132	6.5101841	6.5101841	Pipe retaining plate - 3-way valve
133	6.5610751	6.5610751	DHW heat exchanger guiding plate - right
134	6.1000725	-	Grommet - Gas pipe through sealed chamber (part of sela kit)
135	6.5613921	-	Flue hood
136	6.1000700	-	'O' ring - Primary pipe to heat exchanger (part of seal kit)
137	6.5615441	6.5615441	Gas inlet pipe
138	6.5615201	-	RS chamber right side panel
139	6.5615191	-	RS chamber left side panel
140	6.5102412	-	Combustion chamber front panel
141	6.5614731	6.5614731	Insulation panel set
142	6.5400861	6.5400861	Gas valve control knob body
143	6.5616411	6.5616411	Gas valve control knob top

<b>Ref No.</b>	<b>Ocean Style 80 FF</b>	<b>Ocean Style 80 OF</b>	<b>Description</b>
144	6.1000700	-	Washer 18.5 wrc - main heat exchanger (part of seal kit)
145	6.5610741	6.5610741	DHW heat exchanger guiding plate - left
146	6.5622671	6.5622671	DHW H/Ex to 3-way valve connecting pipe
148	6.5622121	-	Blanking plate
149	6.8421721	-	Terminal block (male)
150	6.8421711	-	Terminal block (female)
151	6.5622424	-	Plastic controls cover (complete)
152	6.5109031	6.5109031	White underside guard
153	6.5401901	6.5401901	Hinge
154	6.5102691	6.5102691	Clip ¾"
155	6.5102701	6.5102701	Clip ½"
156	6.5615531	6.5615531	Heating flow /return elbows - 18 mm
157	6.5615521	6.5615521	Gas inlet elbow - 18 mm
158	6.5615541	6.5615541	DHW inlet/outlet elbows - 14 mm
159	6.5621431	6.5621431	Heating return isolating valve
160	6.5626412	6.5626412	Mains inlet water isolating valve
161	6.5613691	6.5613691	Heating flow isolating valve
162	6.5622681	6.5622681	DHW flow restrictor
163	6.5610111	6.5610111	Heating flow isolating valve - elbow only
164	6.5610701	6.5610701	Wall mounting plate extension c/w screws/plugs
166	6.1000720	6.1000720	Washer 18.5 wrc (part of seal kit)
167	6.1000720	6.1000720	Washer 14.5 wrc (part of seal kit)
170	6.5615241	-	Gas valve to manifold pipe
171	6.5610181	6.5610181	Pump to 3-way valve connecting pipe
172	6.5615311	6.5615311	DHW outlet connection pipe
173	6.5617250	6.5617951	Heat exchanger primary return pipe
174	6.5608363	6.5608363	Heating return pipe to isolating valve
175	6.5204002	-	Fan flange
176	6.5103583	-	Fan mounting plate
177	6.5622591	-	Flue turret
178	6.5615291	6.5617961	Heat exchanger primary flow pipe
179	6.5605911	6.5605911	Heating flow connection pipe
180	6.5203191	6.5203191	3-way valve by-pass pipe to DHW heat exchanger
182	6.5101181	-	Screw for aluminium pipe
183	6.5401732	-	Air duct locking ring
184	6.5616011	-	Aluminium flue duct
185	6.5403591	-	Plastic air duct
186	6.8100742	-	Terminal screw
187	6.1000350	-	Sealing collar
189	6.5206341	-	Flue terminal
-	6.5105792	6.5617331	Outer casing
-	6.8100572	-	Screw (casing)
-	6.5652030	6.5652030	Drain tap
-	6.0001143	6.0001143	Domestic hot water shock arrestor kit
			SEAL KITS
195	6.1000700	6.1000700	Seal kit 700 - Water complete
200	6.1000705	6.1000705	Seal kit 705 - DHW heat exchanger
205	6.1000710	6.1000710	Seal kit 710 - 3-way valve
210	6.1000715	6.1000715	Seal kit 715 - Main heat exchanger
215	6.1000720	6.1000720	Seal kit 720 - Wall plate

Ref No.	Ocean Style 80 FF	Ocean Style 80 OF	Description
220	6.1000725	6.1000725	Seal kit 725 - Gas complete
225	6.1000730	-	Seal kit 730 - Flue turret
			LITERATURE
230	6.9169282	6.9170961	Installation instructions
235	6.9169351	6.9166871	User instructions

**Alpha**  
BOILERS

Alpha Therm Limited.  
Goldsel Road, Swanley, Kent BR8 8EX  
Tel: (01322) 669443  
Fax: (01322) 615017